



Devonport City Council

PUBLIC NOTICE

APPLICATION FOR PLANNING PERMIT

Section 57(3) Land Use Planning Approvals Act 1993

An application for a planning permit has been made which may affect you.

Application Details

Application Number:	PA2025.0116
Proposed Use or Development:	Residential (carport)
Address of the Land:	129 Wrenswood Drive, Quoiba
Date of Notice:	04/10/2025

You are invited to view the application and any documents and plans accompanying it on the ground floor of the paranaple centre at 137 Rooke Street, Devonport or on Council's website www.devonport.tas.gov.au

Any person may make a representation relating to the application in accordance with section 57(5) of the *Land Use Planning Approvals Act 1993*, during a period of 14 days commencing on the date of this notice.

Your representation must:

- be received by close of business on **17/10/2025**;
- be in writing; and
- addressed to the Chief Executive Officer, Devonport City Council:
 - P.O. Box 604, Devonport, Tasmania, 7310; or
 - townplanning@devonport.tas.gov.au

If you make a representation then Council must consider your submission before making its decision on the application.



PA2025.0116 - 129 Wrenswood Drive, Quoiba



This map is made available for the purpose of providing access to Devonport City Council information and not as professional advice. The information contained on the map is diagrammatic only. All information should be verified on site, or with the appropriate State Government Department or Council Office, prior to being used for any purpose.

Copyright © Devonport City Council

Created: 01-10-2025 12:18:56



**Devonport
City Council**

Wrenwood Drive

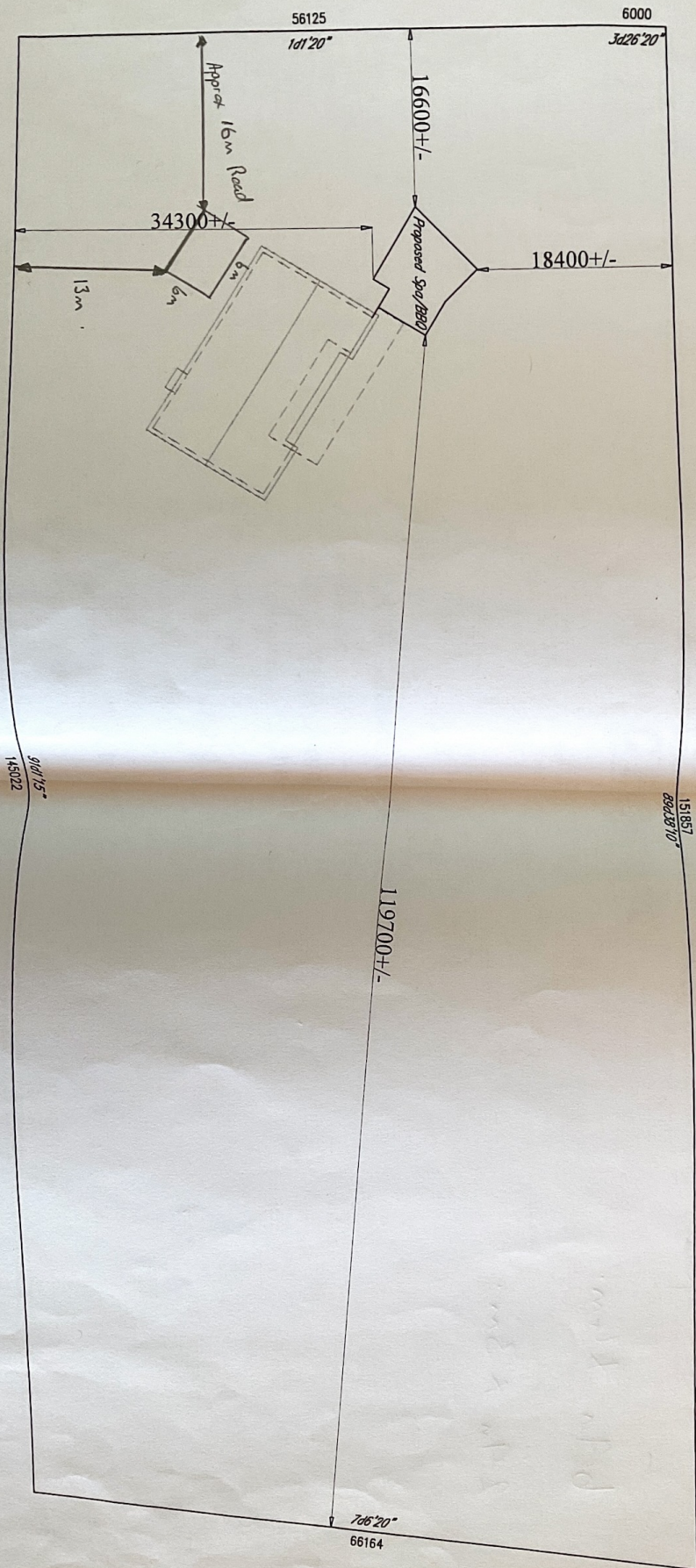

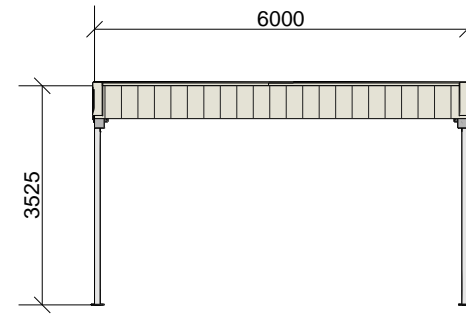

Left

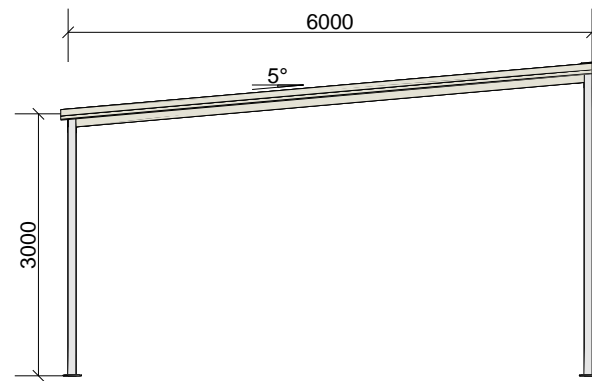

Front

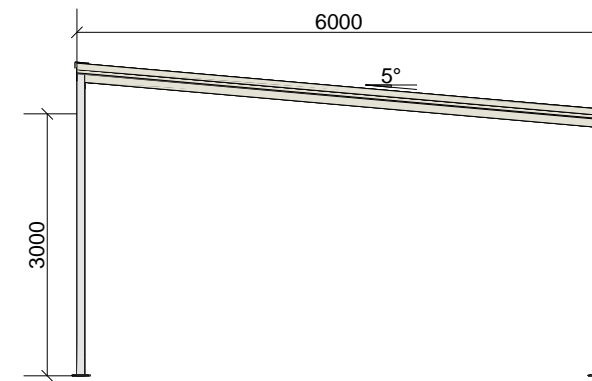

Back

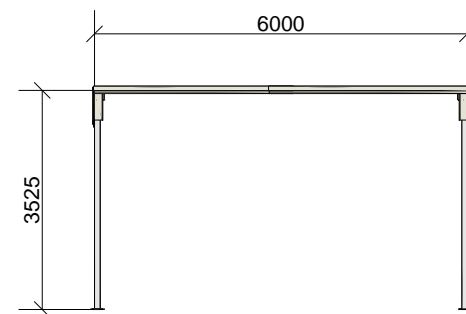

Right

Elevation w/cladding

Upright
Engineering
Kristian March MIEAUST 5469730
02-09-2025

DBS
SHEDS | BATHROOMS
DBS Sheds
33-35 Elizabeth St, Devonport TAS
7310
ABN: 60 625 147 953
Lic:
PH: (03) 6424 6664
E: sheds@dbssheds.com.au

Project No: **J1554-P9519**
Customer: **Craig Emmett**
PH: **0429 427 597**
MOB: **0429 427 597**

Site: **129 Wrenswood Dr, Quoiba TAS 7310**
LOT: RP/SP:
Quote Name: **Carport**
Drawing Set: **CLADELEV1**

Region: **A4**
Terrain Cat: **2.72**
ULT Wind Speed: **43.62**
Servicability: **35.87**

Date: **02/09/2025**
Sheet
12 / 12