

# PLANNING APPLICATION

---

## Status:

### Reference

PLN-HOB-2025-0564

### Address

13 SERVICE ST GLEBE TAS 7000

### Titles

106963/2

## Before you start

---

Before you start your application, you will need to know if you require planning approval or not.

If you are unsure if you require a permit, use the [PlanBuild Tasmania Enquiry Service](#) to lodge a request for advice from the relevant Council.

Once your application has been submitted the Council will review your application. If payment has not been made, you will be sent a request for the payment of application fees via PlanBuild Tasmania.

Once the fees have been paid and the Council is satisfied with the information provided, the application will be assessed and you will be notified of the outcome.

If further action is required to assess your application you will receive an email notification containing a task to complete.

## Pre-Application Advice

---

### Have you spoken with anyone at Council about this application?

Yes - enter details below

No - continue to the next section

### If yes, provide the name of the person you contacted

Liz Wilson

## Applicant

---

Name	Email	Phone	Address	Involvement
Personal Information Removed				

## Owners

---

Name	Email Address	Address
Personal Information Removed		

## Certificate(s) of Title

---

### Selected Titles

106963/2

Total Area: 0m<sup>2</sup>

## Owner Notification

---

### Are you the sole owner of the land?

Yes - continue to the next section

No - answer question below

### If no, have you notified all owners, joint or part owners of your intention to submit this application?

Yes - enter owner details below

No - you must notify all owners before proceeding with this application

List all owners, joint or part owners as recorded on the Title documents notified:

RUSSELL LAWRENCE GOSLIN

Enter the date that the last owner, joint or part owner was notified

31/10/2025

Declaration

I declare that all land owners, joint or part owners have been notified of this planning application.

## Crown Land Consent

---

Is Crown Land involved in the proposed use or development?

Yes - complete question below

No - continue to the next section - see further information below

Unsure

If yes, has written Crown Land consent been obtained?

Yes - upload written consent

No - application will not be progressed until consent has been provided

## General Manager Consent

---

Is Council-owned or administered land involved in the proposed use or development?

Yes - complete question below

No - continue to the next section

Unsure

If yes, has written consent been obtained from the Council General Manager?

Yes - upload written consent

No - application will not be progressed until consent has been provided

## Proposed Use or Development

---

What is the reason for your planning application?

I want to change how the property is used

I want to use the property for visitor accommodation

I want to subdivide

I want to undertake a new development or alteration

I want to do a minor boundary adjustment

I want to put up a sign(s)

I want to demolish

I want to do works only

Other

If your application is to subdivide, please enter the number of proposed lots.

0

If your application is for signage, please enter the number of signs.

Is the property a Tasmanian Heritage Listed Property?

Yes

No

Is the application for an EPA Activity under the Environmental Management and Pollution Control Act 1994?

Yes

No

Unsure

Is the proposed use or development permitted or discretionary?

Permitted

Discretionary

Unsure if permitted or discretionary

**Provide a full description of the proposed use or development**

Solar panel installation. Black panels will be flush mounted to roof in landscape format with black railings and fixtures.

**Will the proposed use or development involve a road reserve?**

Yes - complete the section below

No - continue to the next section

Unsure

If yes, enter the address(es) or locations below:

If yes, how will the road reserve be affected?

## Value of Works

---

What is the estimated value of the works?

27937

## Supporting Documents

---

Version	Document Date	Document Type	Description	Prepared By
1	31 Oct 2025	Detailed Site Plan	Proposed installation	Christine Guglielmino
1	1 Nov 2025	Property Title Document	0 Folio Text 106963_0_2.pdf	Christine Guglielmino
1	1 Nov 2025	Property Title Document	1 Folio Text for common lot 106963/0 106963_0_2.pdf	Christine Guglielmino
1	1 Nov 2025	Property Title Document	2 FOLIO PLAN 106963_0_2.pdf	Christine Guglielmino

## Next steps

---

When you have completed all the necessary fields and attached all required documents to support your application, click on the green 'Save & Submit' button at the top right of this form.

Once submitted, the Council will review your application. A request for the payment of application fees will be sent to you via PlanBuild Tasmania.

Once the fees have been paid and the Council is satisfied with the information provided, the application will be assessed and you will be notified of the outcome.

If further action is required to assess your application you will receive an email notification from PlanBuild which will tell you what you need to provide to continue the application.

Form published: 14/05/2025 15:58

SEARCH OF TORRENS TITLE

VOLUME 106963	FOLIO 2
EDITION 9	DATE OF ISSUE 21-Jul-2024

SEARCH DATE : 01-Nov-2025

SEARCH TIME : 12.24 PM

DESCRIPTION OF LAND

City of HOBART

Lot 2 on Strata Plan [106963](#) and a general unit entitlement operating for all purposes of the Strata Scheme being a 10 undivided 1/20 interest

Derived from Strata Plan [106963](#)

Derivation : Part of 10 Acres Gtd. to J. Whyte and Ors.

SCHEDULE 1

[M955168](#) TRANSFER to RUSSELL LAWRENCE GOSLIN Registered  
09-May-2022 at 12.01 PM

SCHEDULE 2

Reservations and conditions in the Crown Grant if any  
The registered proprietor holds the lot and unit entitlement subject to any interest noted on common property  
Folio of the Register volume [106963](#) folio 0

[E387751](#) MORTGAGE to Australia and New Zealand Banking Group Limited Registered 21-Jul-2024 at 12.01 PM

UNREGISTERED DEALINGS AND NOTATIONS

E435735 DISCHARGE OF MORTGAGE [E387751](#) Lodged by DYE & DURHAM (NAB) on 06-Oct-2025 BP: E435735

E435736 MORTGAGE to National Australia Bank Limited Lodged by DYE & DURHAM (NAB) on 06-Oct-2025 BP: E435735

SEARCH OF TORRENS TITLE

VOLUME 106963	FOLIO 0
EDITION 2	DATE OF ISSUE 19-Apr-2006

SEARCH DATE : 01-Nov-2025

SEARCH TIME : 12.24 PM

DESCRIPTION OF LAND

City of HOBART

The Common Property for Strata Scheme [106963](#)

Derivation : Part of 10 Acres Gtd. to J. Whyte and Ors.

Prior CT [32638/39](#)

SCHEDULE 1

STRATA CORPORATION NUMBER [106963](#), 13-15 SERVICE STREET HOBART

SCHEDULE 2

Reservations and conditions in the Crown Grant if any

UNREGISTERED DEALINGS AND NOTATIONS

No unregistered dealings or other notations

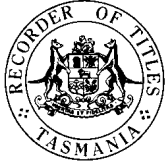

Conveyancing and Law of Property Act 1884

REGISTERED NUMBER

106963

STRATUM PLAN

Sheet 1 of 3 Sheets

City or Town HOBART

Locality GLEBE

Reference to Title CT 32638-39

Site comprises the whole of Lot 1 on Plan No. D.106962 in the Diagram

Lands Titles Office

The name of the building is 13 - 15 SERVICE STREET HOBART

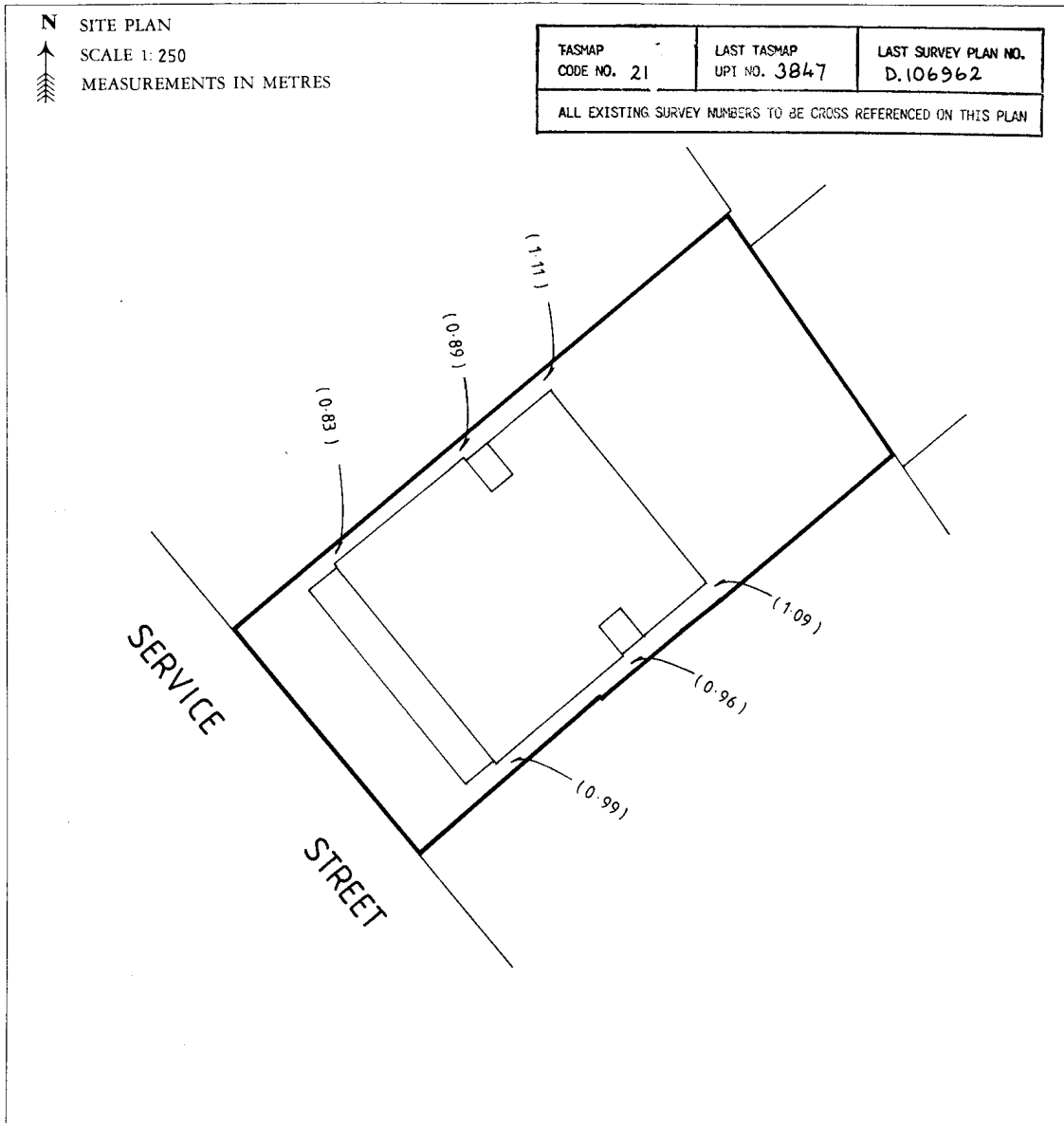

External surface boundaries of the site and the location of the building in relation thereto to be delineated in this space



REGISTERED this 5<sup>th</sup> day of OCTOBER 1993, No.106963

This plan is lodged for registration by  
HOBART CITY COUNCIL

*M. H. ...*  
Recorder of Titles

OS-D 754

Sheet 2 of 3 Sheets

No. 106963

*[Signature]*  
Town Clerk/Council Clerk

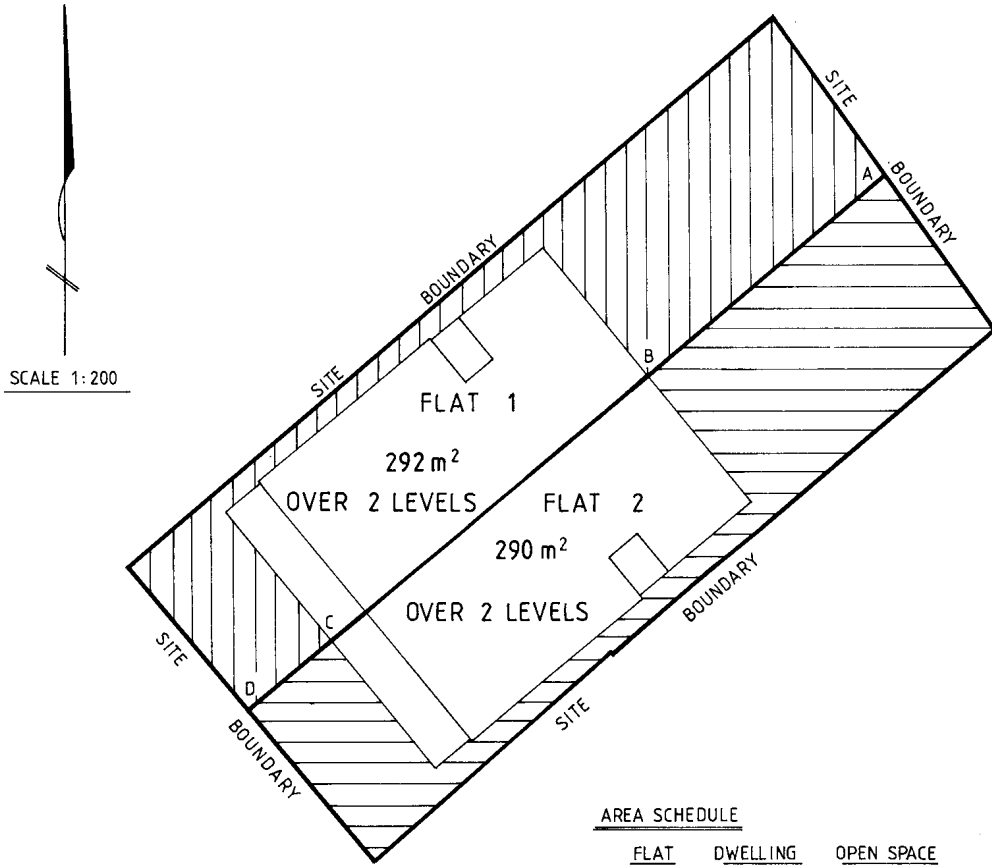

AREA SCHEDULE

FLAT	DWELLING	OPEN SPACE
1	156 m <sup>2</sup>	136 m <sup>2</sup>
2	156 m <sup>2</sup>	134 m <sup>2</sup>

THE HORIZONTAL BOUNDARIES OF EACH FLAT ARE SHOWN BY HEAVY UNBROKEN LINES AND ARE DEFINED BY SITE BOUNDARIES OR DESCRIPTION AS THE CASE MAY BE

A - B IS THE CENTRELINE OF A PALING FENCE

B - C IS THE CENTRELINE OF WALL

C - D IS THE PROLONGATION OF THE WALL B - C

THE VERTICAL BOUNDARIES OF EACH FLAT EXTEND FROM 1 METRE BELOW GROUND LEVEL TO 10 METRES ABOVE GROUND LEVEL

THE HATCHED AREAS ARE PRIVATE OPEN SPACE





# 6.175 solar w/Tesla 13.5kw

**Addressed to:**

Russell Goslin

[0421616830](tel:0421616830)

[russell.goslin@corneum.com.au](mailto:russell.goslin@corneum.com.au)

13 Service Street

Glebe TAS 7000

Prepared by Edward Guglielmino on 30th October  
2025

Last updated on 31st October 2025

Offer valid until 31st January 2026

Reference #: PJ-0000-2043-5

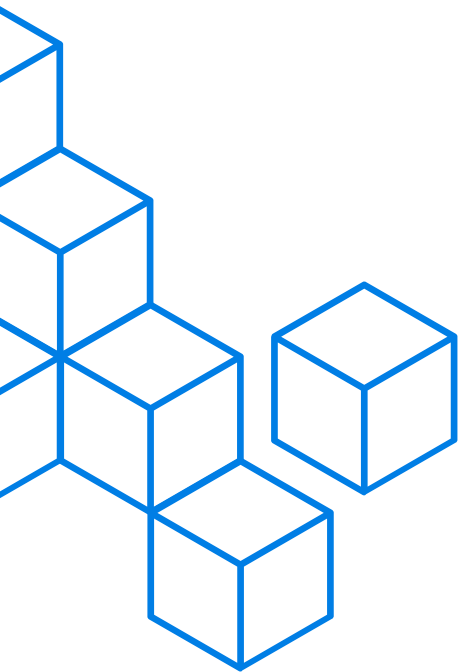

## SOLARGEN PTY LTD

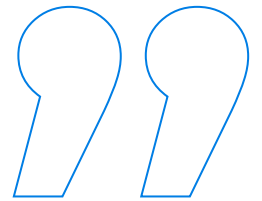

We are SolarGen — a proudly Tasmanian owned and operated solar business. We are passionate about delivering top-tier solar solutions while supporting our local community and the state we love. From the first consultation to the final installation, you will be working directly with us — no dodgy sales tactics, just honest advice and high-quality work. We believe in doing things right the first time, and we are committed to keeping you informed every step of the way. No surprises, no shortcuts — just solid service and solar you can count on.

# Proposed panel layout

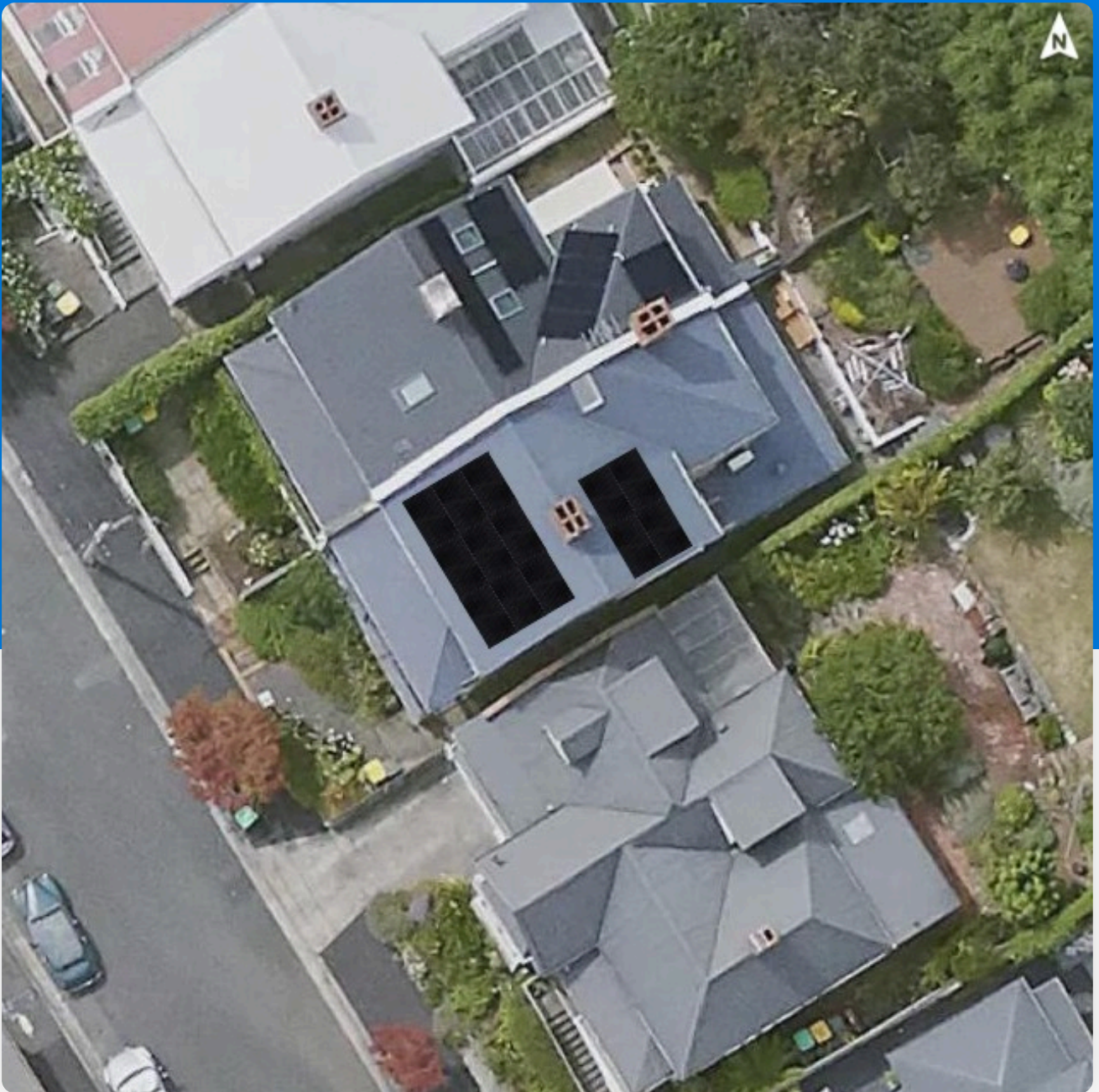

13 Service Street  
Glebe TAS 7000

## Panel strings & component markings





## Daily production per month

How much electricity will my system generate per day, on average?

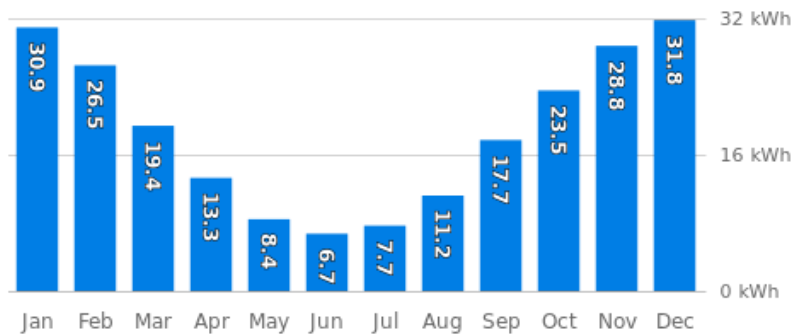

## System details

Your custom design

### Solar system size<sup>1</sup>

6.175 kW<sub>DC</sub> (STC)

### Battery size

14.4 kWh (13.5 kWh usable)

### Estimated annual production<sup>2</sup>

6,856 kWh

### Solar panel

13 × 475W WINAICO WBC Series Ultra Black · WST-475BDX54-B2  
1,800 × 1,134 mm · Monocrystalline · [Datasheet](#) · [Warranty](#)

### Inverter

1 × Tesla Powerwall 3 · 10000W  
Single phase · 97.5% max. efficiency · [Datasheet](#) · [Warranty](#)

### Battery storage<sup>3</sup>

1 × Tesla Powerwall 3 · 14.4kWh  
609 × 1,099 × 193 mm · 13.5kWh usable · LFP · [Datasheet](#) · [Manual](#) · [Warranty](#) · [Safety](#)

### EV charger

1 × MyEnergi Zappi · 7kW  
Single phase · Type 2 · [Datasheet](#)

### Mounting system

Clenergy PV-ezRack SolarRoof  
Flush mounted, tin (penetrative) EliteRail · [Datasheet](#) · [Warranty](#) · [Engineering Cert.](#)

### System efficiency<sup>4</sup>

87%



## Utility costs

How much will I save after installing solar?

### Before solar

\$333.33  
Average monthly bill

\$4,000.00  
Annual bill

### With solar

**\$168.82 ↓ 49%**  
First year average

**\$2,025.83 ↓ 49%**  
Estimated annual savings \$1,974.17



## Self-consumption

How much of your solar power will be consumed on-site. More is better.

**Solar only**  
56%

**With storage**  
89% ↑33%



## Energy balance

Where will your power come from?

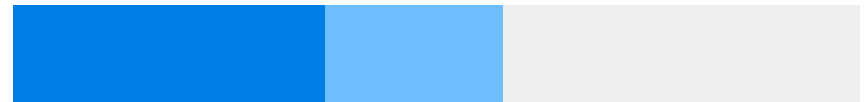

**Solar**  
37%

**Battery storage**  
21%

**Utility**  
42%



## Battery performance<sup>3</sup>

How will you make the most of your battery storage?

### Morning

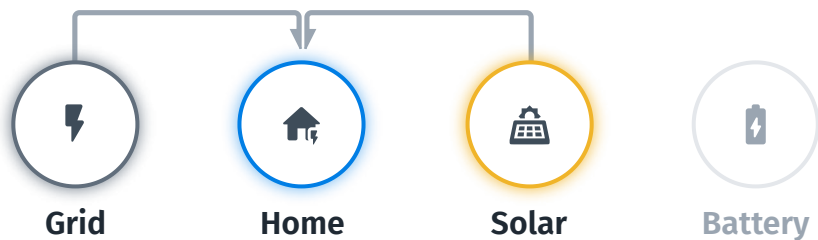

### Afternoon

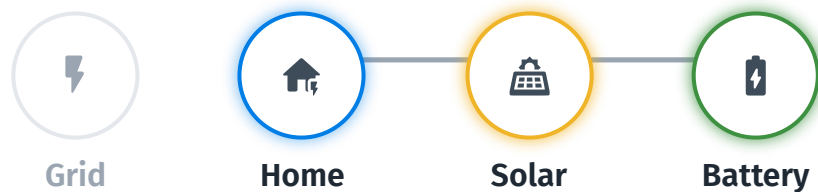

### Night

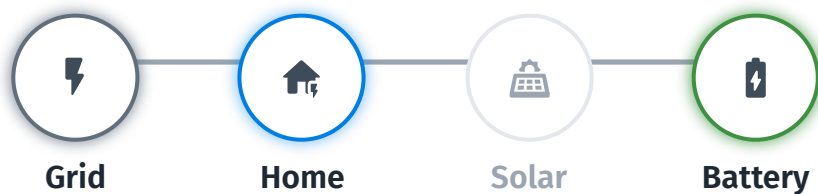

## 20 year financial summary

Your historical electricity bills were used to help size your solar system. Based upon the system size suggested, the expected electricity bill savings over a 20 year period are provided below.

In addition, the first-year electricity bill savings you can expect are provided together with a chart of the monthly solar system output you can expect.

### \$27,370.42

#### Net present value of investment<sup>5</sup>

The Net Present Value (NPV) is the **present day value** of all future cash inflows minus the outflows. Since money is worth more in the present day than in the future, all future cashflows need to be discounted by inflation. A positive NPV indicates a good investment.

### 9–10 years

#### Discounted payback period<sup>5</sup>

Similarly, the Discounted Payback Period also accounts for all discounted future cashflows. The resulting period will typically be longer than a "simple payback period" calculation.

### 125%

#### Total return on investment<sup>5</sup>

The Return on Investment (ROI) is another measure of the efficiency of your solar investment. Imagine you invested \$100.00 today and received \$300.00 in return. The ROI would be 200%.

### 10.1%

#### Internal Rate of Return<sup>5</sup>

The Internal Rate of Return is the discount rate that is used such that the NPV of future cash flows is exactly zero. The higher IRR, the better



“Energy-efficient homes can sell for as much as 10 per cent more”

— *Dr Daniel Daly*

[Read more »](#)

## Annual bill<sup>5</sup>

- Electricity bill without solar
- Electricity bill with solar

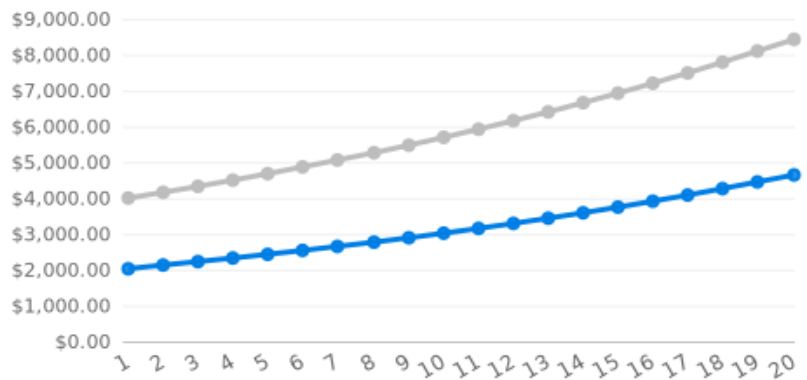

## Monthly electricity bill comparison<sup>5</sup>

- Electricity bill without solar
- Electricity bill with solar

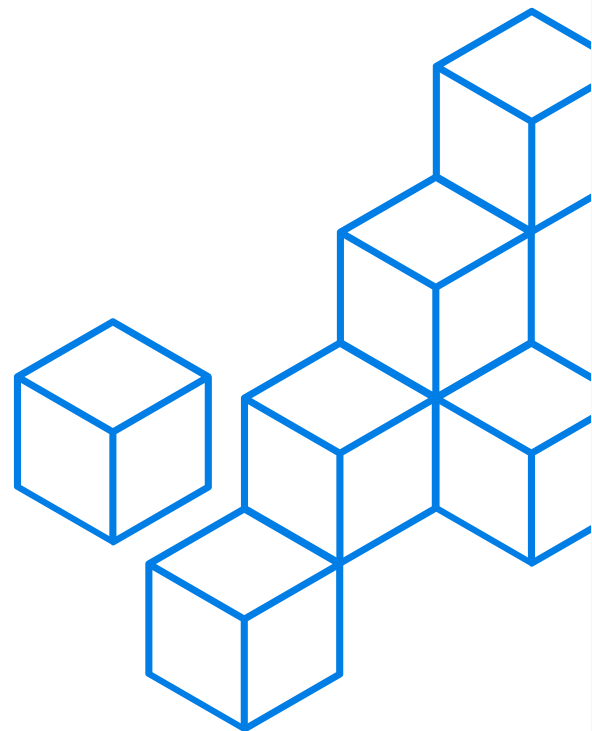
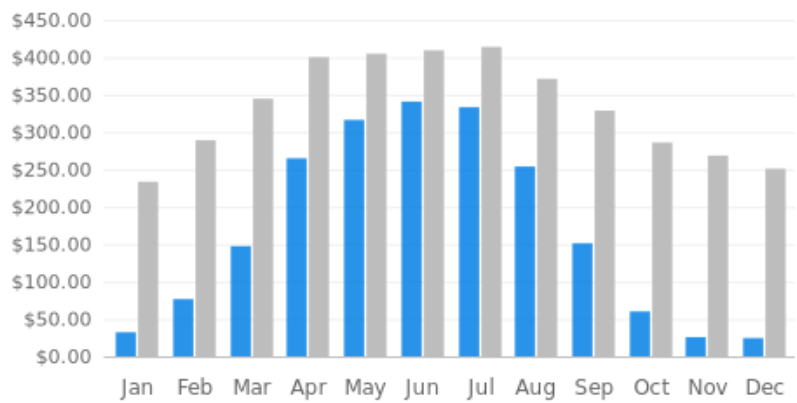



## Environmental Analysis

Your solar system will generate significant environmental benefits. These come primarily from avoided power plant emissions.



**124**

Trees planted equivalent per year<sup>6,7</sup>



**2,059**

Avoided equivalent fuel per year (L)<sup>6,7</sup>



**2,340**

Avoided coal burnt per year (kg)<sup>6,7</sup>



# Quote



**To** Russell Goslin  
 0421616830  
[russell.goslin@cormeum.com.au](mailto:russell.goslin@cormeum.com.au)  
**Address** 13 Service Street  
 Glebe TAS 7000

**From** SOLARGEN PTY LTD  
 ABN: 86680827918  
**Reference #** PJ-0000-2043-5  
**Prepared on** 30th October 2025  
**Expiry date** Jan 31, 2026

Description	Quantity	Price	Total
6.175kW Solar system with home energy system			
<b>EV Charger</b> MyEnergi ZAPPI-2H07TW	1	\$1,750.00	\$1,750.00
<b>Solar Panel</b> WINAICO WBC Series Ultra Black WST-475BDX54-B2 (475W)	13	\$307.80	\$4,001.40
<b>Battery Storage</b> Tesla Powerwall 3 (14.4kWh / 13.5kWh usable)	1	\$12,700.00	\$12,700.00
<b>Inverter</b> Tesla Powerwall 3 (10kW) - built-in inverter	1	(incl.)	
Racking/balance for tin/colorbond roofing	13	\$86.00	\$1,118.00
Freight - Hobart	6,175	\$0.03	\$185.25
Installation & labour	6,175	\$0.34	\$2,099.50
Battery installation	1	\$1,500.00	\$1,500.00
Tesla Gateway Device	1	\$1,850.00	\$1,850.00
Hobart Local Provisions Schedule (LPS) heritage planning application and associated advertising	1	\$450.00	\$450.00
Landscape panels additional fixtures	13	\$30.00	\$390.00
Two story plus height surcharge	1	\$640.00	\$640.00
TasNetworks grid application	1	\$0.00	\$0.00
*Must have stable 2.4GHz Wi-Fi signal at inverter location*		(incl.)	
Cable Run From MSB to Inverter and EV Charger \$30 per meter x 20 m to powerwall 3 \$30 per meter x 10m to EV charger	1	\$900.00	\$900.00
Discount for 50% deposit	-0.09	\$24,294.57	-\$2,186.51
		Subtotal excl. GST	\$25,397.64
		GST	\$2,539.76
		43 STCs <sup>8</sup> x \$36.00	-\$1,548.00
		125 Battery STCs <sup>8,9</sup> x \$36.00	-\$4,500.00
		<b>Total incl. GST</b>	<b>\$21,889.40</b>

**Acceptance**

-

Please sign and return to SOLARGEN PTY LTD. Be sure to keep a copy for your own records. A 50% (\$10,944.70) deposit is required to initiate the process. Final payments are to be made upon full completion of installation. **Offer valid until 31st Jan 2026**

**Payment Milestones**

-

Percentage	Description	Amount
50%	Deposit to secure booking and materials	\$10,944.70
50%	Installation Completion	\$10,944.70

**Payment**

-

BSB: 067873  
Account no. 18874447  
SOLARGEN PTY LTD

CBA

Reference #: PJ-0000-2043-5

---

**Client Name**

---

**Client Signature**

---

## Additional Information

-

---

**Storeys**  
2

**Power phases**  
Single phase

---

**Energy Retailer**  
Aurora

**Distributor**  
TasNetworks

**NMI**  
8000140617

---

## Notes

-

---

By accepting this proposal you confirm you have read and understood which circuits (if any) are backed up by a battery.

## Assumed values

### DC Array Power Tilt Azimuth

4.275kW                    22°   240°  
1.9kW                        22°   60°

Azimuth measured clockwise from North

### System efficiency<sup>4</sup>

87%

### AC system size

10kW

### Export limit

No export limit

### Annual electricity bill

\$4,000.00 (Annual)

### Utility rate inflation

4% per annum

### Self-consumption rate

88.55%

### Daily supply charge

\$1.40

### Current electricity price

\$0.34

### Feed-in Tariff

\$0.09

### System lifetime

20 year

### Inflation rate <sup>10</sup>

2.1% per annum

### Effective interest rate <sup>10</sup>

1.36% per annum

### PV degradation

WINAICO WBC Series Ultra Black

WST-475BDX54-B2

99% for the first year

-0.35% per year to year 30

### Nominal storage capacity

14.4kWh

### Maximum depth of discharge

100%

### Usable storage capacity

13.5kWh

### Power

11.04kW

### Round trip efficiency

98%

### Battery STCs factor (2025)

9.3 STCs per usable kWh

## Assumptions and Disclaimer

---

- <sup>1</sup> The Standard Test Condition rating (STC) assumes a standard set of optimal operating conditions (25°C cell temperature, 1000 W/m<sup>2</sup> and an air mass of 1.5). The STC rating is most often used by manufacturers to classify the power output of PV modules. To calculate the system's energy production for any future year, the expected degradation in system performance is included (See "PV degradation", in table below).
- <sup>2</sup> Energy Output is calculated based on historical solar irradiance at the given location. A typical meteorological year is selected using statistical methods. Factors including panel tilt, orientation (azimuth), and system efficiency are taken into account.
- <sup>3</sup> Battery storage devices may not always provide Back-up, Grid Islanding or Uninterruptible Power Supply (UPS) capabilities.
- <sup>4</sup> System efficiency is estimated to account for losses caused by a variety of factors. These factors include intermittent shading, cable losses, dirt, scheduled downtime, manufacturer tolerances, inverter efficiency for DC to AC (this does not affect off-grid DC only systems), battery round trip efficiency, and other factors.
- <sup>5</sup> Utility electricity price inflation is adjusted based on the given location.(Figures from NATIONAL ELECTRICITY FORECASTING REPORT June 2016 by AEMO.)
- <sup>6</sup> Clean Energy Regulator. 2024. Electricity sector emissions and generation data 2022-23. [ONLINE] Available at: <https://cleanenergyregulator.gov.au/markets/reports-and-data/nger-reporting-data-and-registers/electricity-sector-emissions-and-7>.
- <sup>7</sup> United States Environmental Protection Agency. 2017. Greenhouse Gases Equivalencies Calculator - Calculations and References. [ONLINE] Available at: <https://www.epa.gov/energy/greenhouse-gases-equivalencies-calculator-calculations-and-references#kilowatt>
- <sup>8</sup> Australian Small-scale Technology Certificates (STCs) are an incentive provided under the Renewable Energy Target. One certificate is equal to one megawatt hour of eligible renewable electricity either generated or displaced by the installed system. [ONLINE] Read more at: <https://cer.gov.au/schemes/renewable-energy-target/small-scale-renewable-energy-scheme/small-scale-technology-certificates>.
- <sup>9</sup> Battery STCs calculated for the Commonwealth Government's Cheaper Home Batteries Program are based on an assumption of 9.3 STCs per usable kWh of storage. [ONLINE] Read more at: <https://cer.gov.au/schemes/renewable-energy-target/small-scale-renewable-energy-scheme/small-scale-renewable-energy-systems/solar-batteries>.
- <sup>10</sup> Inflation and effective interest rates are sourced from the RBA. 20 year bond rate is used as the nominal rate. [ONLINE] Available at: <https://www.rba.gov.au/>

**Note** The system design may change based on a detailed site audit. Estimated savings are based on past electrical usage and utility rates provided by the customer where applicable. Actual system production and savings will vary based on final system design, configuration, utility rates, applicable subsidies and your energy usage post-solar installation. Utility rates, charges and fee structures imposed by your utility are not affected by this proposal and are subject to change in the future at the discretion of your utility. The production calculations in this report are based on historical climate data for the site location and represent typical estimates of future solar production.

**System end-of-life** This system's lifetime expectancy is outlined in the Warranty section below. System removal at end-of-life may incur additional costs. Please contact us for more information on System End-of-life Disposal Services.

**System portability** This system has been designed for and is intended to be permanently fixed to the property as shown in the Proposed Panel Layout section above. It is not portable and should not be moved without a professional. Please contact us if you would like to modify the location of your installed solar system.

## Warranty

Product	Type	Standard warranty	Downloads
WINAICO WBC Series Ultra Black WST-475BDX54-B2 475W	Solar panel	30 years product, 30 years performance	<a href="#">Warranty file</a>
Tesla Powerwall 3 10000W	Inverter	10 years	<a href="#">Warranty file</a>
Tesla Powerwall 3 13.5kWh	Battery	10 years	<a href="#">Warranty file</a>
Clenergy PV-ezRack SolarRoof - Tin (penetrative), flush mounted, EliteRail	Mounting system	25 years	<a href="#">Warranty file</a>

System component warranties are different from the system lifetime. Please see the Assumed Values page.

## Manufacturers

Product	Manufacturer	Contact	Address
Tesla Powerwall Powerwall 3 Tesla Powerwall 3	TESLA ENERGY VENTURES AUSTRALIA PTY LTD ABN: 24 665 982 365	powerwallsupport@tesla.com +61 1 800 294 431	546 Gardeners Road Alexandria NSW 2000

## **PV-ezRack<sup>®</sup> SolarRoof<sup>™</sup>**

Code-Compliant Planning and Installation Guide V4.1  
Complying with AS/NZS1170.2-2011 AMDT 2-2016



## 1. Introduction

The Clenergy PV-ezRack® SolarRoof™ has been developed as a universal PV-mounting system for roof-mounting on pitched and flat roofs. The use of patented aluminium base rails, Z-Module technology and telescopic mounting technology eliminates custom cutting and enables fast installation.

Please review this manual thoroughly before installing PV-ezRack® SolarRoof™. This manual provides

- 1) Supporting documentation for building permit applications relating to PV-ezRack® SolarRoof™ Universal PV Module Mounting System,
- 2) Planning and installation instructions.

### List of Contents

Introduction	01
Planning	02
Tools & Component list	05
System Overview	08
Installation Instruction	10
Certification Letter and Interface Spacing Table	32

The PV-ezRack® SolarRoof™ parts, when installed in accordance with this guide, will be structurally sound and will meet the AS/NZS1170.2:2011 Amdt 2- 2016 standard. During installation, and especially when working on the roof, please comply with the appropriate Occupational Health and Safety regulations. Please also pay attention to any other relevant State or Federal regulations. Please check that you are using the latest version of the Installation Manual, which you can do by contacting Clenergy Australia via email on [sales@clenergy.com.au](mailto:sales@clenergy.com.au), or contacting your local distributor in Australia.

### The installer is solely responsible for:

- Complying with all applicable local or national building codes, including any updates that may supersede this manual;
- Ensuring that PV-ezRack and other products are appropriate for the particular installation and the installation environment;
- Using only PV-ezRack parts and installer-supplied parts as specified by PV-ezRack project plan (substitution of parts may void the warranty and invalidate the letter of certification);
- Recycling: Recycle according to the local relative statute;
- Removal: Reverse installation process;
- Ensuring that there are no less than two professionals working on panel installation;
- Ensuring the installation of related electrical equipment is performed by licenced electricians;
- Ensuring safe installation of all electrical aspects of the PV array, This includes adequate earth bonding of the PV array and PV-ezRack® SolarRoof™ components as required in AS/NZS 5033-2014 AMDT 2 2-2018;
- Ensuring that the roof, its rafters/purlins, connections, and other structural support members can support the array under building live load conditions;
- Ensuring that screws to fix interfaces have adequate pullout strength and shear capacities as installed;
- Maintaining the waterproof integrity of the roof, including selection of appropriate flashing;
- Verifying the compatibility of the installation considering preventing electrochemical corrosion between dissimilar metals. This may occur between structures and the building and also between structures, fasteners and PV modules, as detailed in AS/NZS 5033: 2014.
- Verifying atmospheric corrosivity zone of installation site by referring to AS 4312-2008 or consulting local construction business to determine appropriate products and installations.

## 2. Planning

### 2.1 Determine the wind region of your installation site

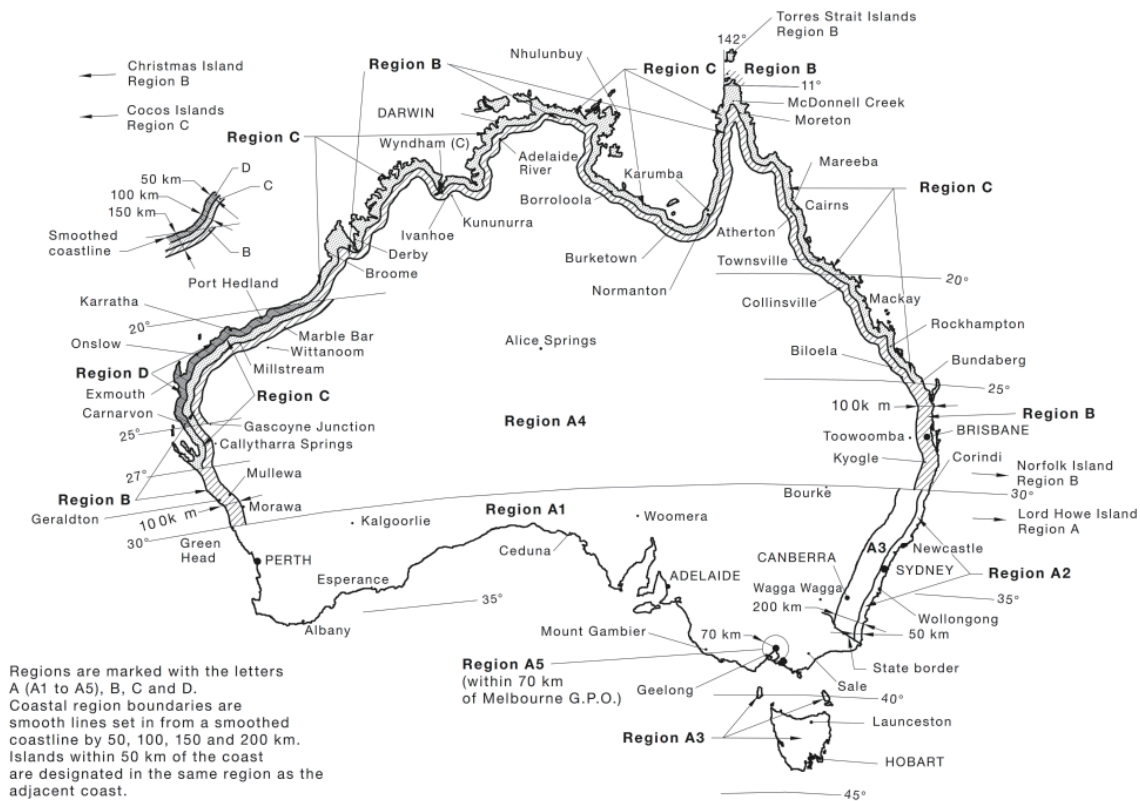

#### Region Definition:

Wind regions are pre-defined for the whole of Australia by the Australian Standard 1170.2. The Wind Region is an independent factor of surrounding topography or buildings.

- Most of Australia is designated Region A which indicates a Regional Wind Velocity of 43 m/s with wind average recurrence of 200 years.
- Some areas are designated Region B (52 m/s). Local authorities will advise if this applies in your area.

- Region C areas (64 m/s) are generally referred to as Cyclonic and are generally limited to northern coastal areas. Most Region C zones end 100km inland.
- Region D (79 m/s) is Australia's most extreme Cyclonic Region, located between the town of Carnarvon and Pardoo Station in Western Australia.

## 2.2 Determine the Terrain Category

You will need to determine the terrain category to ensure the installation meets the required standard.

Terrain Category 1 (TC1) – Very exposed open terrain with few or no obstructions and enclosed, limited-sized water surfaces at serviceability and ultimate wind speeds in all wind regions, e.g. flat, treeless, poorly grassed plains; rivers, canals and lakes; and enclosed bays extending less than 10km in the wind direction.

Terrain Category 1.5 (TC1.5) – Open water surfaces subjected to shoaling waves at serviceability and ultimate wind speeds in all wind regions, e.g. near-shore ocean water; larger unenclosed bays on seas and oceans; lakes; and enclosed bays extending greater than 10km in the wind direction. The terrain height multipliers for this terrain category shall be obtained by the linear interpolation between the values for the TC1 and TC2.

Terrain Category 2 (TC2) – Open terrain, including grassland, with well-scattered obstructions having heights generally from 1.5m to 5m, with no more than two obstructions per hectare, e.g. farmland and cleared subdivisions with isolated trees and uncut grass.

Terrain Category 2.5 (TC2.5) – Terrain with a few trees or isolated obstructions. This category is intermediate between TC2 and TC3 and represents the terrain in developing outer urban areas with scattered houses, or larger acreage developments with fewer than ten buildings per hectare. The terrain-height multipliers for this terrain category shall be obtained by linear interpolation between the values for the TC2 and TC3.

Terrain Category 3 (TC3) – Terrain with numerous closely spaced obstructions having heights generally from 3m to 10m. The minimum density of obstructions shall be at least the equivalent of 10 house sized obstructions per hectare, e.g. suburban housing or light industrial estates.

Terrain Category 4 (TC4) – Terrain with numerous larger, high (10m to 30m tall) and closely-spaced buildings, such as large city centers and well-developed industrial complexes.

If your installation site is not at TC 2, 2.5 or 3, please contact Clenergy to obtain a project specific engineering certificate to support your installation.

## 2.3 Verify Atmospheric Corrosivity Zone of Installation Site

Please refer to "AS 4312-2008 Atmospheric Corrosivity Zones in Australia" or consult local construction business to verify corrosivity category of installation site to determine appropriate products and interface spacing. When standard products are installed in high corrosivity zones, like C4/C5, interface spacing reduction factor need to be applied. Please refer to the generic notes of Certification Letter for the details.

Note: Clenergy provided screws for Tin interfaces are suitable for up to C3 corrosive environments only.

## 2.4 Determine the Height of the Installation Site

This document provides sufficient information for the PV-ezRack® SolarRoof™ system installation up to heights of 30 meters. If your installation site is more than 30 meters high please contact Clenergy to obtain project specific engineering certificate to support your installation.

## 2.5 Determine Roof slope

The PV-ezRack® SolarRoof™ system can be used for roof slopes up to 60°. Please verify that the Installation site roof slope is between 0° and 60°.

## 2.6 Determine the Installation Area of Roof

Please refer to the generic notes 28, 29 and 31 of Certification Letter to determine the installation area based on building height, length and width. Please be aware at certain building conditions there is an Exclusion Zone for flush installation, which is the minimum distance between PV solar panel and roof edge of "2s", where "s" is the gap between the underside of the panel and the roof surface.

## 2.7 Verify Rafter/Purlin Properties of Building

Please verify rafter/purlin properties of building, which could affect the interface spacing. For example, tin interface spacing on the metal purlin in the certification letter is based on steel purlin G450 1.5 mm thick. If the steel purlin is less than 1.5 mm thick, the corresponding reduction factor of interface spacing will be applied. Please refer generic notes for details.

## 2.8 Determine the Maximum Rail Support Spacing

Please refer to the Certification Letter and Interface Spacing Table. If a project specific Certification Letter has been provided, please refer to the support spacing in this letter.

## 2.9 Verify Maximum Rail End Overhang

Rail end overhang should be not over 40% of the interface spacing. For example, if the interface spacing is 1500mm, the Rail end overhang can be up to 600mm only.

## 2.10 Acquire PV Modules Clamping Zone Information

It is recommended to acquire PV modules clamping zone info. from PV modules manufacturer, which can help to plan interfaces positions on the roof and rails orientation and positions.

# Tools and Components

## 3. Tools and Components

### 3.1 Tools

#### Tools



Angle Grinder with Stone Disk



Screw Driver  
(for M8 Hexagon Socket Screw)



Torque Spanner



Spanner



5m Tape



String & Marker Pen

### 3.2 Components

#### Component list

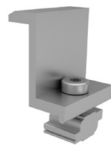

ER-EC-ST  
End Clamp



ER-IC-ST  
Inter Clamp



C-U/30/46-G  
Universal Clamp



C-U/30/46  
Universal Clamp



ER-EC-DU35/40  
End Clamp, Dual 35 or  
40mm



ER-EC-DU40/46  
End Clamp, Dual 40 or  
46mm



ER-R-ECO  
ECO Rail



ER-SP-ECO  
Splice for ECO Rail



SCO-ECO/380  
Side Channel Cover for ECO-  
Rail, length 380 mm

## Component list



ER-I-41/EZC/ECO  
Adjustable Tile Interface  
with ezClick connection,  
120 mm horizontal arm



ER-I-61/EZC/ECO  
Adjustable Tile Interface  
with ezClick connection,  
170 mm horizontal arm



ER-I-01  
Tile Interface



ER-I-01/CS  
Tile Interface, Carbon  
Steel



ER-I-01/EZC/ECO  
Tile Interface with  
ezClick connection for  
ECO-Rail



ER-I-02  
Flat Tile Interface



ER-I-04  
Slate Interface



ER-I-23  
Tile Interface-Landscape



ER-I-26  
Tile Interface-Side mount

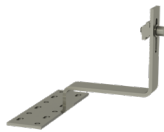

ER-I-51  
Tile Interface, 118mm  
horizontal arm



ER-I-05  
Tin Interface



ER-I-05/CM  
Tin Interface with Click  
Module



ER-I-05A/EZC/ECO  
Tin Interface A with  
ezClick connection



ER-I-25  
Tin Interface with Curved  
Base for Corrugated Roof

## Component list



ER-HB-8/150  
Hanger Bolt for wood  
purlin



ER-HB-MP/8/150EP  
Hanger Bolt for metal purlin



EZ-RE-200  
Roof Hook Extender

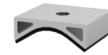

EZ-AD-C43  
Adapter (Puck) for  
Corrugated Iron Roof



EZ-GC-ST  
Grounding clip



EZ-GL-ST  
PV-ezRack Grounding Lug  
with Copper Pipe



IS-SR265/111  
Isolator Shade, non-  
assembly (Mill Finish)



AB-SR/IS/260  
Angle Bracket

# System Overview

## 4. System Overview

### 4.1 Overview of PV-ezRack SolarRoof

- Tile Roof



- ① End Clamp    ② Inter Clamp    ③ ECO Rail    ④ Tile interface    ⑤ Splice for ECO Rail

- Tin Roof

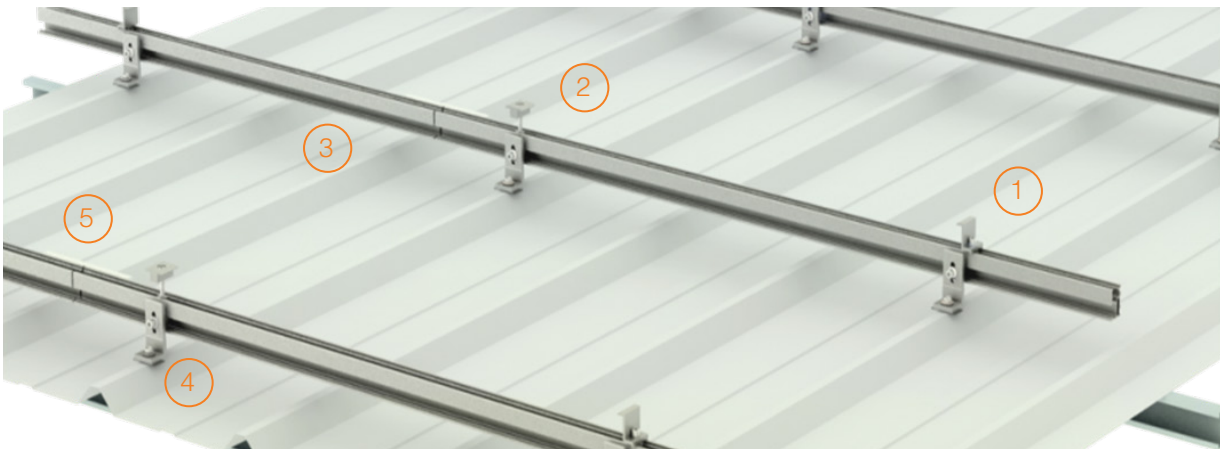

- ① End Clamp    ② Inter Clamp    ③ ECO Rail    ④ Tin interface    ⑤ Splice for ECO Rail

## 4.2 Precautions during Stainless Steel Fastener Installation

Improper operation may lead to deadlock of Nuts and Bolts. The steps below should be applied to stainless steel nut and bolt assembly to reduce this risk.

### 4.2.1 General installation instructions:

- (1) Apply force to fasteners in the direction of thread
- (2) Apply force uniformly, to maintain the required torque
- (3) Professional tools and tool belts are recommended
- (4) In some cases, fasteners could be seized over time. As an option, if want to avoid galling or seizing of thread, apply lubricant (grease or 40# engine oil) to fasteners prior to tightening.

### 4.2.2 Safe Torques

Please refer to safe torques defined in this guide as shown in the figures below. When fixing mid and end clamps, if the torques range specified by the panel manufacturer is different, it should be used instead. In case power tools are required, Clenergy recommends the use of low speed only. High speed and impact drivers increase the risk of bolt galling (deadlock) If deadlock occurs and you need to cut fasteners, ensure that there is no load on the fastener before you cut it. Avoid damaging the anodized or galvanized surfaces.

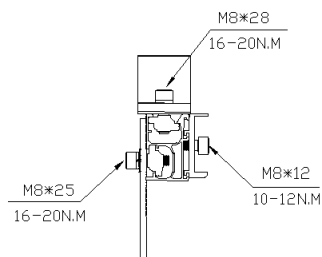

ER-I-01 and other tile interfaces

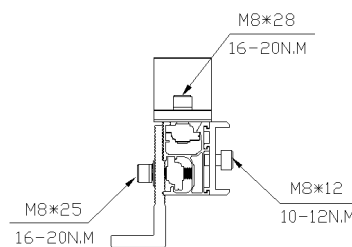

ER-I-05 and ER-I-25

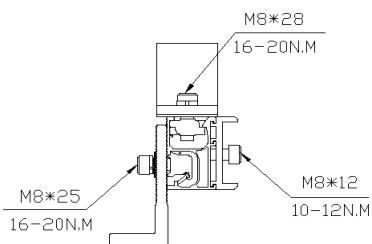

ER-I-05/CM

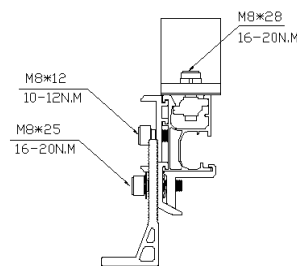

ER-I-05A/EZC/ECO

## 4.3 Installation Dimensions

All drawings and dimensions in this Installation Guide are a generic reference only. PV-ezRack® SolarRoof™ is to be optimized to suit specific conditions for each project and should be documented in a construction drawing.

Major components of PV-ezRack® SolarRoof™ may be provided in section sizes and lengths varying from those shown in this guide. The installation process detailed in this instruction guide remains the same regardless of changes in component size.

If you need to do any on-site modifications or alteration of the system please provide marked up drawings/sketches for Clenergy's review, prior to modification, for comment and approval.

## 5. Installation Instruction

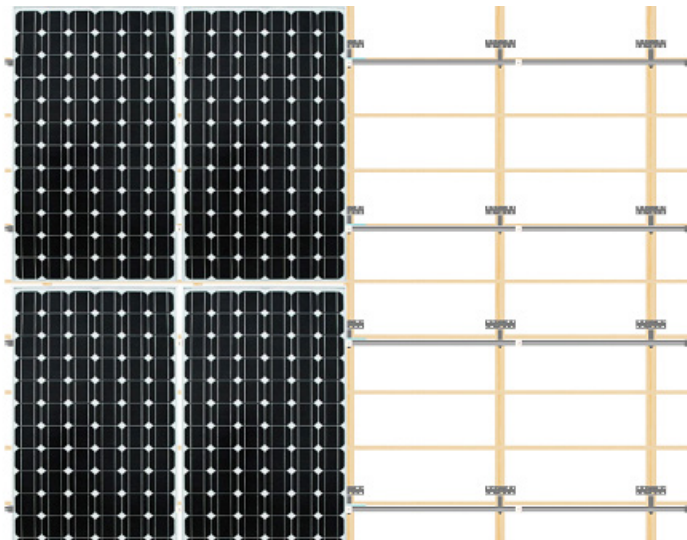

- Assess the number of modules in the vertical direction using the module height plus at least 18mm between modules (please check the installation manual of the solar module manufacturer);
- Assess the Number of modules in the horizontal direction using the module width plus 18 mm (20 mm if using Universal Clamps) between the modules.

**Note: The standard end clamp will also add 20 mm (except for dual end clamps) on each side to the space required;**

- Assess the horizontal spacing of the Roof Hooks;
- Assess the vertical spacing of the Roof Hooks = approx. 1/2 to 3/4 of module height;
- Always check the installation manual of the PV-Module you use in order to determine the allowed fixing points on the module frame.

## 5.1 Tile Interface Installation

5.1.1 Determine the positions of the Roof Hooks according to your plans. Remove the roof tiles at the marked positions or, if possible, simply push them up slightly.

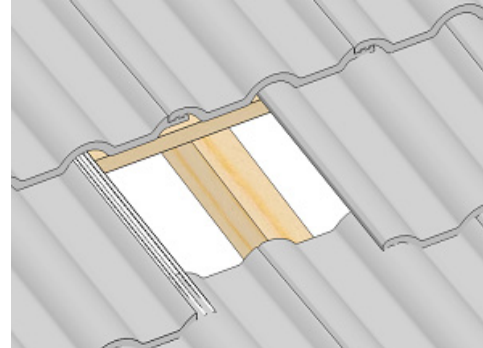

5.1.2 Fix the Roof Hooks to the rafter using Clenergy provided Buildex 14 gauge Hex Head Zips screw with minimum 25 mm embedment as shown in the figure on the right following the Buildex screws installation guide below:

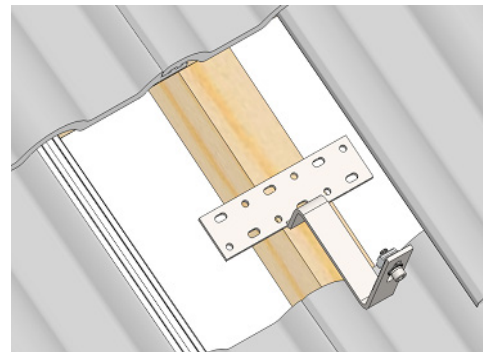

- Use a 3/8" Hex Socket.
- Use a mains powered or cordless screw driver with a drive speed of 3,000 RPM maximum.
- Fit the driver bit into the screw and place at the fastening position.
- Apply consistently firm pressure (end load) to the screw driver until the screw is fastened.

5.1.3 The roof hook must not press against the roof tile. If necessary, pack the roof hook with max pack height of 17 mm for Clenergy provided Buildex 50 mm long screw, with max pack height of 35 mm for Clenergy provided Buildex 65 mm long screw.

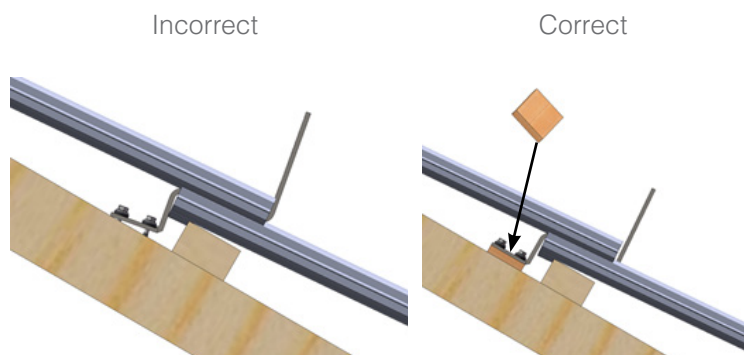

Note: When installing Adjustable Tile Interface (ER-I-41/EZC/ECO or ER-I-61/EZC/ECO), height can be adjustable from 35mm to 50mm.

The recommended torque of bolt for height adjustment is 16-20 N·m.

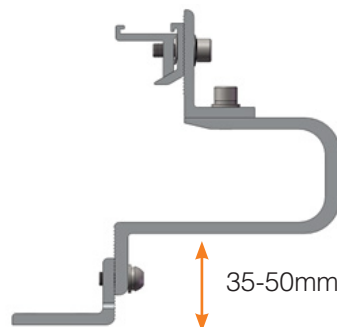

# Installation Instruction

5.1.4 If necessary, use an angle grinder to cut a recess in the tile covering the Roof Hook at the point where the Roof Hook extends so that the tile lies flat on the surface. If grooved tiles are used, it will also be necessary to cut a recess in the lower tile.

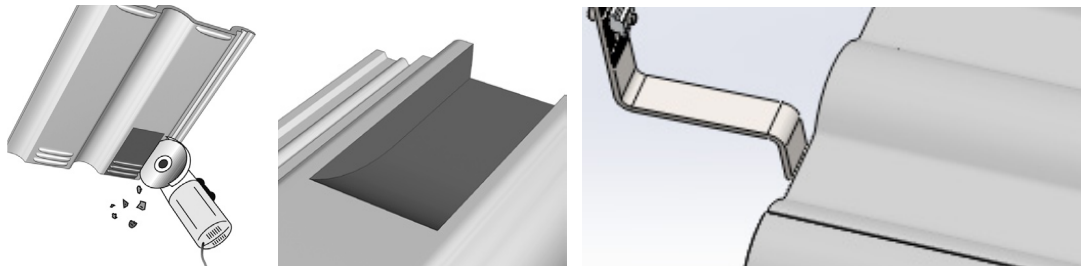

5.1.5 Caution! Do not use fitted roof hooks as a ladder, as this extreme point load could damage the tile below.

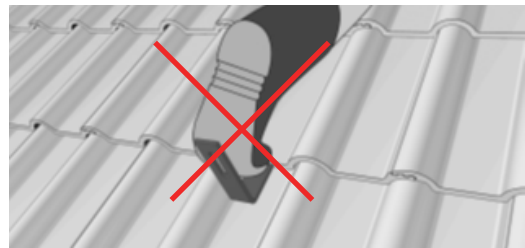

5.1.6 Variation for installation on plain tile roofs with plain tile roof cladding: A recess must be cut into the tiles around the position of the roof hook. The tile flashing should be used if necessary to prevent ingress of water.

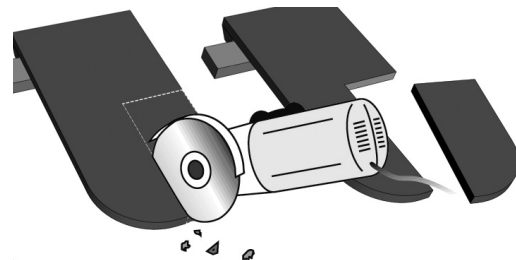

## 5.2 Rail Installation

5.2.1 To connect several rails together, slide half of the splice into the rear side of the rail. Fasten the first M8 Bolt using an Allen key, and slide the next rail into the splice. Tighten the second M8 Bolt using an Allen key. The total rail length is recommended not to be over 30 meters considering rails thermal expansion problem. Splice provides the electrical connection between the 2 rails through the pressure bolts. This eliminates the need of using 2 earthing lugs. Recommended torque is 10 ~12 Nm.

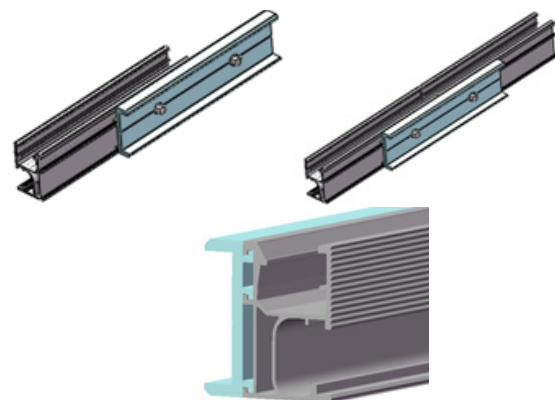

# Installation Instruction

5.2.2 If the rails consist of different lengths, always begin with the shortest piece. Install the PV modules on the Roof Hooks and fasten loosely with M8 x 25 bolt and washers as shown in the figure on the right. Two to three screw turns are adequate for loose installation.

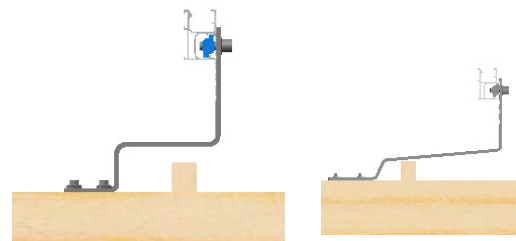

ER-I-01

ER-I-02

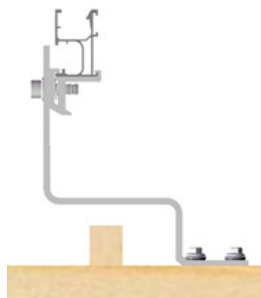

ER-I-01/EZC/ECO

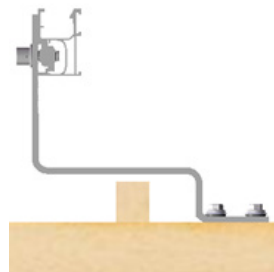

ER-I-51

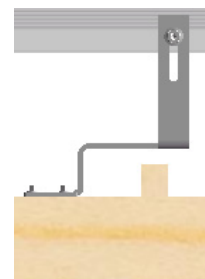

ER-I-23

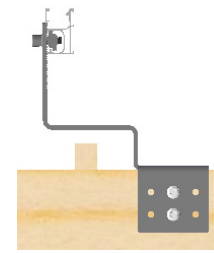

ER-I-26

5.2.3 Adjustable Tile Interface (ER-I-41/EZC/ECO or ER-I-61/EZC/ECO) can adjust L profile bracket on the top to achieve rail running parallel or perpendicular to the rafter. See the figures below.



ER-I-41/EZC/ECO

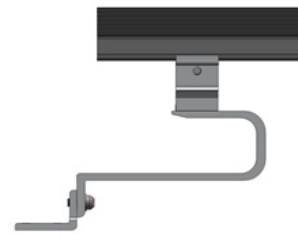
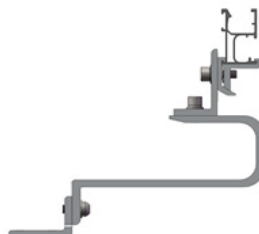

ER-I-61/EZC/ECO

# Installation Instruction

5.2.4 Adjust the vertical and horizontal positioning using the long hole in the Roof Hook and the loosely connected Z Module in the rail, as shown in the figure on the right. The roof hook should not protrude over the rail after the adjustment.

The recommended torque is 16 ~20Nm.

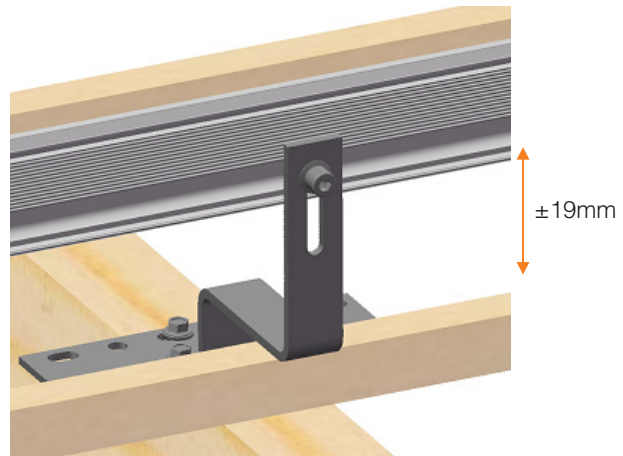

## 5.3 PV Module Installation

### 5.3.1 Deployment of Grounding Clips

1) When there is an even number of PV Module in each row:

Install the grounding clips at the positions marked X in the figure shown. Then the number of Grounding Clips = number of PV Module.  
Eg; 4 grounding clips in the figure shown.

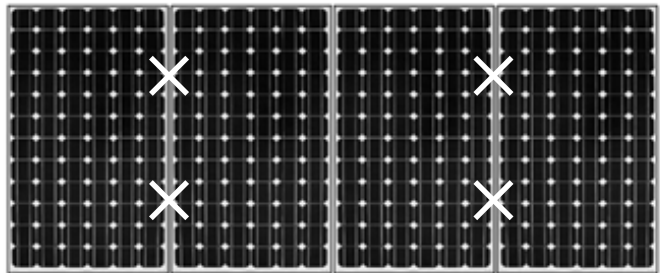

2) When there is an odd number of PV Module in each row:

Install grounding clips at positions marked X in figure shown.

Then the number of Grounding Clips = number of PV Module + 1. Eg; 6 grounding clips in figure shown.

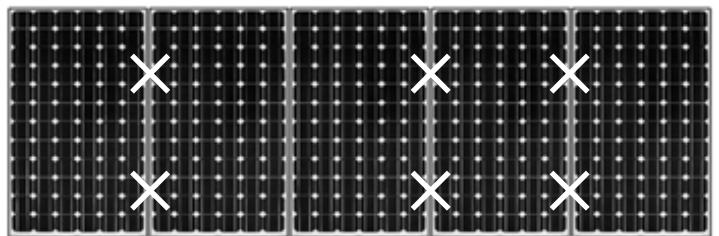

### Important Notes:

- When replacing defective PV Modules, it is required to replace the grounding clips under the defective PV Modules.
- When removing defective PV Modules, it is required to keep sufficient grounding clips to maintain all other PV modules' earthing continuity with the rail. It is required to install grounding clips under end clamps when necessary to achieve this.

5.3.2 Before installing the PV modules on horizontal rail installations, add anti-slip protection to the lowest row of PV modules. To do this, fasten M6 x 20 mm bolts (with the shank downwards) to the lower mounting holes of the PV module frame. When installing large modules (e.g. ASE250) M8 x 20 mm bolts must be used.

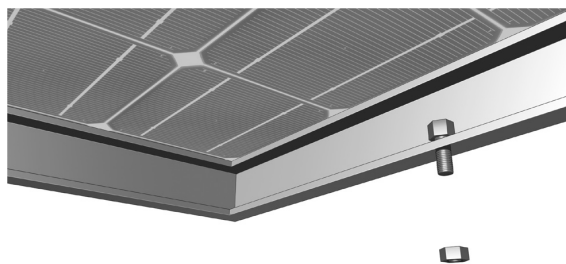

# Installation Instruction

5.3.3 Place the PV Modules on to the rails and fix with End Clamps, Inter Clamps or Universal Clamps. Fasten with the Allen key. Please use Solution 1 or 2 below according to your project.

-Solution 1 (Apply Standard Clamps)

-Step 1 Place the first PV Module on the Rail according to your plan, and fix it in place using the End Clamps. Then fasten lightly with the Allen Key as shown in the figure on the right.

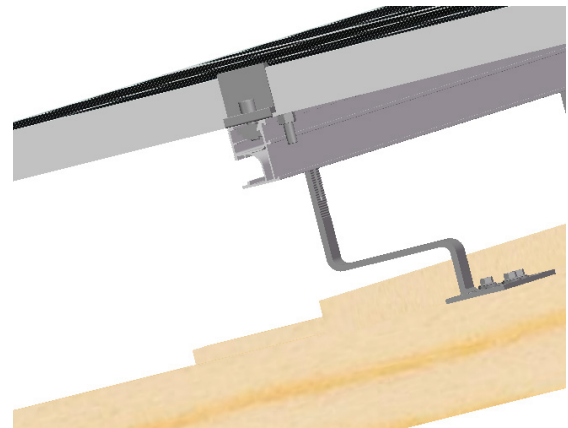

-Step 2 Slightly lift the PV Module and slide Inter Clamps and Grounding Clips into position. The teeth on Grounding Clip will automatically align when the Inter Clamp is properly installed as shown in the figure on the right.

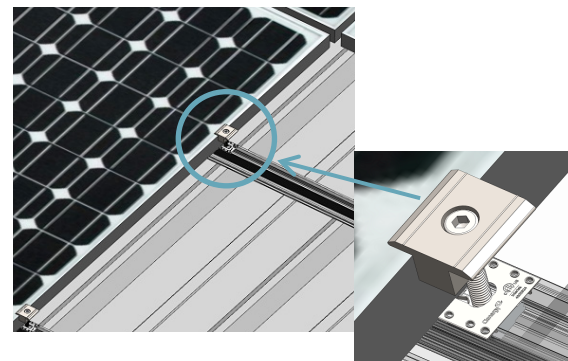

-Step 3 loosely place the next framed PV Module into the other side of the Inter Clamp and Grounding Clip as shown in the figure on the right.

## Important Notes:

-To fix the Grounding Clip properly, ensure the frames of PV Modules are completely pressed against the Inter Clamps and Grounding Clips. Visually check that Grounding Clips are positioned properly.

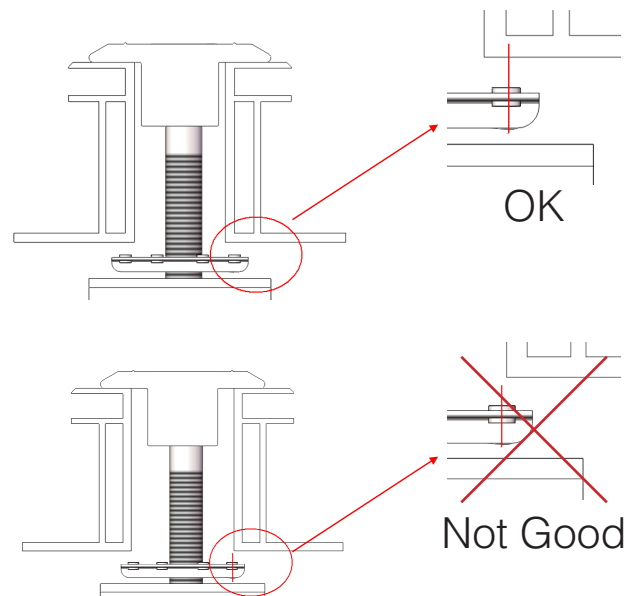

# Installation Instruction

-Grounding Clips are intended for SINGLE USE ONLY! Only fasten the bolts down when the position of the PV Module is finalized. (Only slightly tighten bolts to keep PV Modules in place prior to the final check)

-Solution 2 (Apply Universal Clamps)

Step 1 Twisting the head of the Universal Clamp changes the functionality from End to Inter Clamp as shown in the figure on the right.

NOTE: Please ensure the Universal Clamp C-U/30/46 or Universal Clamp with Grounding Clip C-U/30/46-G is positioned correctly according to 5.3.1: Deployment of Grounding Clip.

Step 2 Incline the Universal Clamp to fit the lower channel against the lower channel of the Rail, and press the Universal Clamp down towards the other side to securely fit the upper channel against the upper rail channel, as shown in the figure on the right

Note: Before installation, make sure there is enough clearance between the screw and lower module of Universal Clamp as shown in the figure on the right.

Step 3 Place the first PV Module on the Rails and apply the Universal Clamp in the End Clamp position and fasten slightly with the Allen Key. Make sure the frame of the PV Module is fully in contact with the Universal Clamp as shown in the figure on the right. Visually check the Universal Clamp and PV module are properly installed.

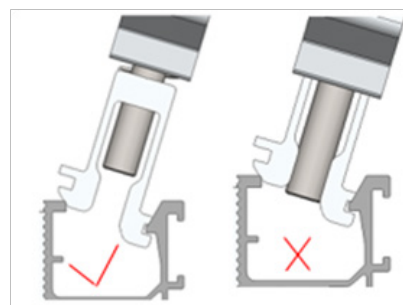
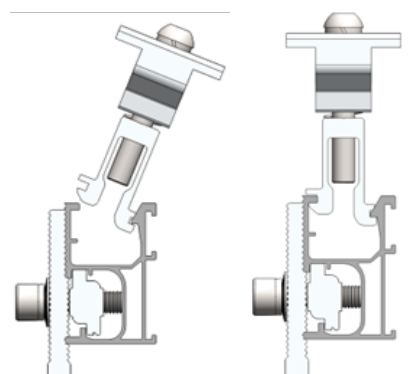
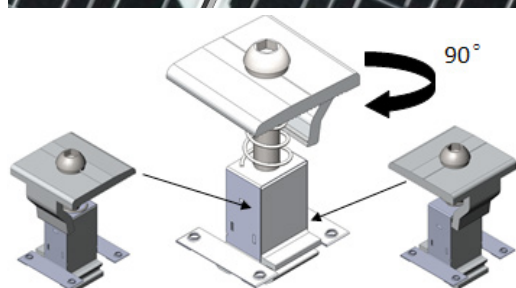
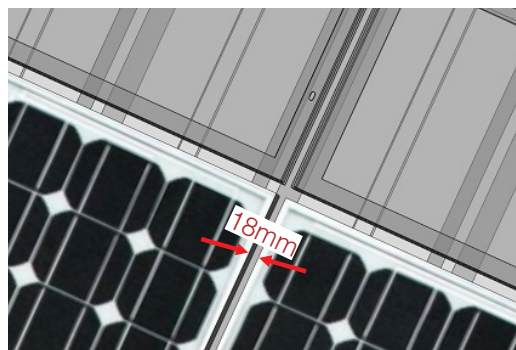

# Installation Instruction

Step 4 When using as an Inter Clamp, click the Universal Clamp into the rail channel and slightly lift the framed PV Module to ensure the Grounding Clip is fully covered as shown in the figure on the right.

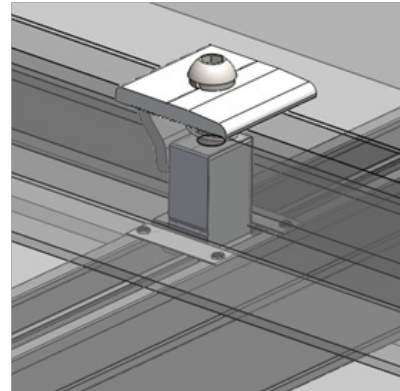
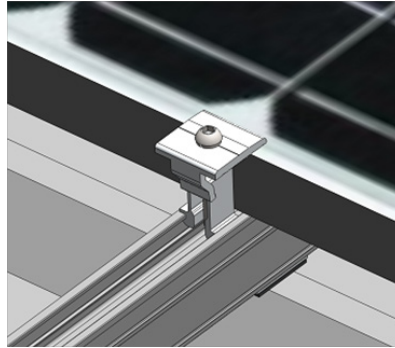

Step 5 Loosely place the next framed PV Module into the other side of the Universal Clamp. Ensure the Grounding Clip is fully covered and ensure the frame of the PV Module is in close contact with Universal Clamp as shown in the figure on the right.

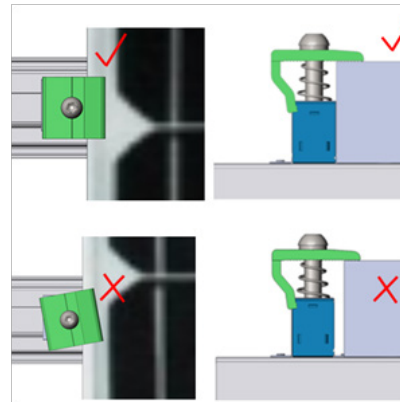

Step 6 Repeat steps above to install all PV Modules. Visually check the Universal Clamps and PV modules are properly positioned and then fasten all Clamps.

When you using Universal Clamps, the gap between two adjacent PV Modules is 20mm. The recommend torque for Universal Clamps in the End Clamp position is 13~14N·m. The recommend torque for Universal Clamps in the Inter Clamp position is 16~20N·m.

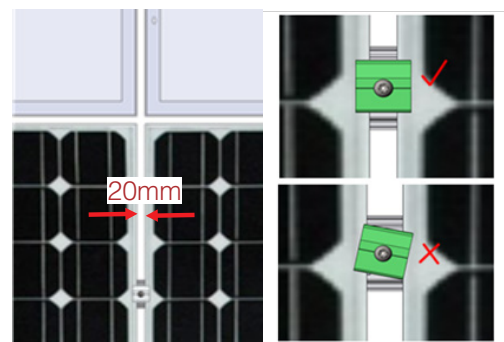

# Installation Instruction

5.3.4 Apply one pre-assembled Grounding Lug per Rail. Slide the Grounding Lug into to the rail channel and fasten the bolt M8\*25 with 16~20 N·m. Strip earthing cable (the maximum size is 10 mm<sup>2</sup>) and insert the conductor into the provided copper tube. Place the copper tube into the channel of Grounding Lug and tighten M6\*10 with 5~6 N·m to ensure the earthing cable is tight.

Note: Check the electrical resistance between rail and earthing cable conductor to ensure the bonding is made.

There are three solutions for Grounding Lug installation:

-Solution 1

Fix the Grounding Lug into the top channel of Rail as shown in the figure on the right.

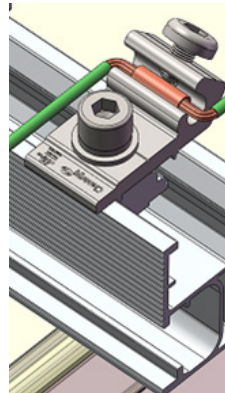

-Solution 2

Fix the Grounding Lug into the top channel of Rail where just under the PV Module as shown in the figure on the right.

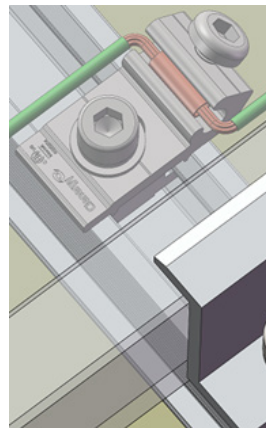

-Solution 3

Fix the Grounding Lug at the side channel of Rail as shown in the figure on the right.

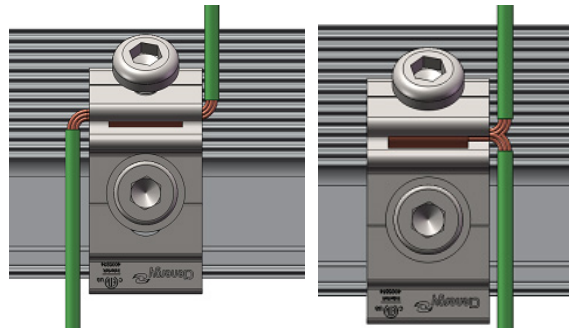

5.3.5 Slide the first PV module of the second row onto the corresponding module of the first row. Separation from the lower PV module can be maintained for aesthetic reasons. An Inter Clamp can be used as a separator, so that the vertical and horizontal separation of the PV modules is identical. Continue mounting the modules as described in steps 5.3.1 to 5.3.6 until all PV modules are installed.

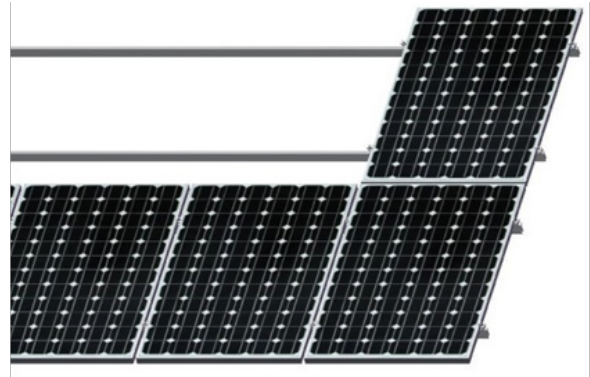

## 5.4 Tin Interface Installation

5.4.1 For installations using ER-I-05, Tin Interface equipped with Buildex 14-11 x 70 (14 gauge, 6.3 mm, 11 TPI, 70 mm long) Hex Head Zips screw. Fix the ER-I-05 at the planned locations on metal or wood purlins as shown in the figure on the right following the Buildex screws installation guide below:

- Use a 3/8" Hex Socket.
- Use a mains powered or cordless screw driver with a drive speed of 3,000 RPM maximum.
- Fit the driver bit into the screw and place at the fastening position.
- Apply consistently firm pressure (end load) to the screw driver until the screw is fastened.

Repeat 5.2 and 5.3 to install the Rails and PV Modules.

Note:

- The purlin thickness should be no less than 0.75mm and no more than 2.4mm;
- Please refer to the recommended torques in 4.2.3 Safe Torques;
- Screws not exposed to frequent rain should be washed down with fresh water at least every 6 months to meet the warranty conditions of Buildex screws.

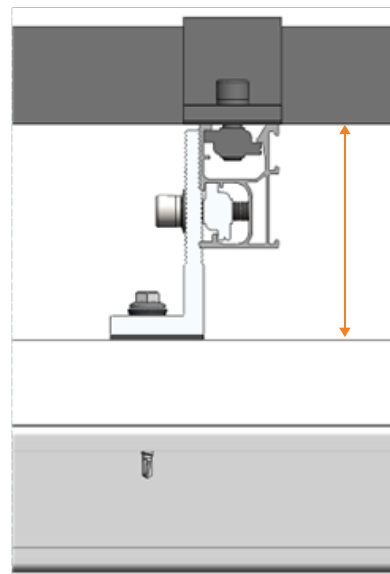

Clearance  
85~100mm

# Installation Instruction

5.4.2 For installations using ER-I-05/CM, Tin Interface with Click Module, equipped with Buildex 14-11 x 70 (14 gauge, 6.3 mm, 11 TPI, 70 mm long) Hex Head Zips screw. Fix the ER-I-05/CM at the planned locations on metal or wood purlins as shown in the figure on the right following the Buildex screws installation guide above. Repeat 5.2 and 5.3 to install the Rails and PV Modules.

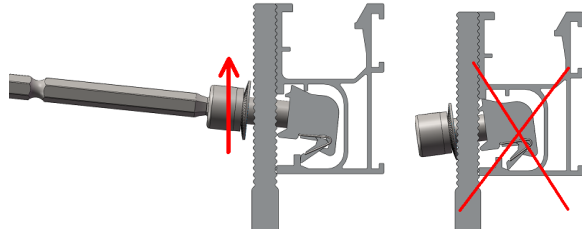

When fastening ER-I-05/CM with rail, it needs to lift up the bolt of click module to make click module well touch with upper rib of side channel of rail. So, the click module can be fixed into the rail properly as shown in the figure on the right.

Note:

- The purlin thickness should be no less than 0.75mm and no more than 2.4mm;
- Please refer to the recommended torques in 4.2.3 Safe Torques;
- Screws not exposed to frequent rain should be washed down with fresh water at least every 6 months to meet the warranty conditions of Buildex screws.

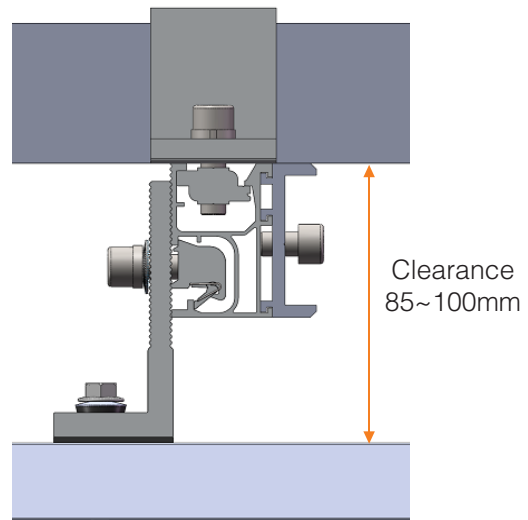

5.4.3 For installations using ER-I-05A/EZC/ECO, Tin Interface with ezClick connection with Buildex 14-11 x 70 (14 gauge, 6.3 mm, 11 TPI, 70 mm long) Hex Head Zips screw. Fix the ER-I-05A/EZC/ECO at the planned locations on metal or wood purlins as shown in the figure on the right following the Buildex screws installation guide above. Repeat 5.2 and 5.3 to install Rails and PV Modules.

Note:

- The purlin thickness should be no less than 0.75mm and no more than 2.4mm;
- Please refer to the recommended torques in 4.2.3 Safe Torques;
- Screws not exposed to frequent rain should be washed down with fresh water at least every 6 months to meet the warranty conditions of Buildex screws.

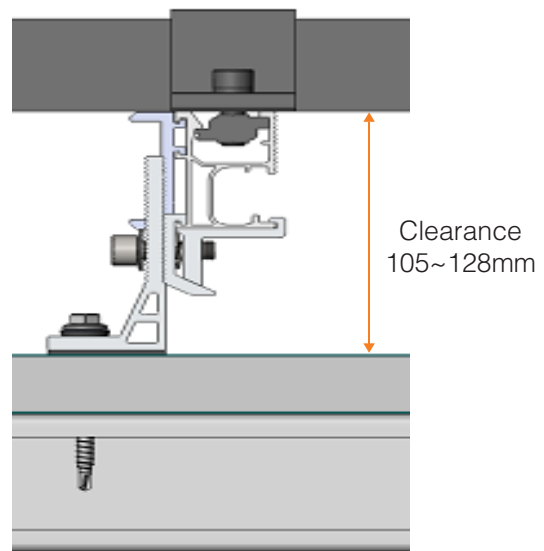

# Installation Instruction

5.4.4 For installations using ER-I-25, Tin Interface with Curved Base for Corrugated Roof with Buildex 14-11 x 70 (14 gauge, 6.3 mm, 11 TPI, 70 mm long) Hex Head Zips screw. Fix the ER-I-25 at the planned locations on metal or wood purlins as shown in the figure on the right following the Buildex screws installation guide above. Repeat 5.2 and 5.3 to install Rails and PV Modules.

Note:

- The purlin thickness should be no less than 0.75mm and no more than 2.4mm;
- Please refer to the recommended torques in 4.2.3 Safe Torques;
- Screws not exposed to frequent rain should be washed down with fresh water at least every 6 months to meet the warranty conditions of Buildex screws.

5.4.5 For installations using EZ-AD-C43 and ER-I-05, Adapter (Puck) for Corrugated Iron Roof and Tin Interface. Attach the EZ-AD-C43 on the planned position and then fix the ER-I-05 on metal or wood purlins as shown in the figure on the right following the Buildex screws installation guide above.

Repeat 5.2 and 5.3 to install Rails and PV Modules. Note: The purlin thickness should be no less than 0.75mm and no more than 2.4mm.

Note:

- The purlin thickness should be no less than 0.75mm and no more than 2.4mm;
- Please refer to the recommended torques in 4.2.3 Safe Torques;
- Screws not exposed to frequent rain should be washed down with fresh water at least every 6 months to meet the warranty conditions of Buildex screws.

**NOTE:**  
**WHEN USING TIN INTERFACES FOR INSTALLATION WORKS, SCREWS NOT EXPOSED TO FREQUENT RAIN SHOULD BE WASHED DOWN WITH FRESH WATER AT LEAST EVERY 6 MONTHS TO MEET THE WARRANTY CONDITIONS OF BUILDDEX SCREWS.**

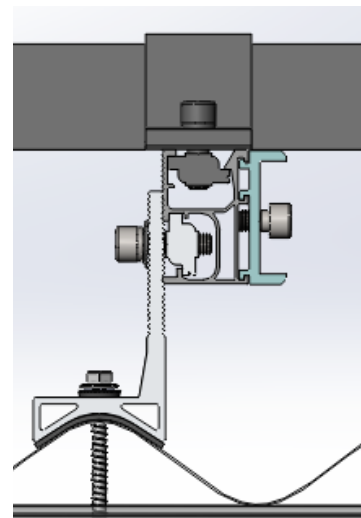

Clearance  
89~104mm

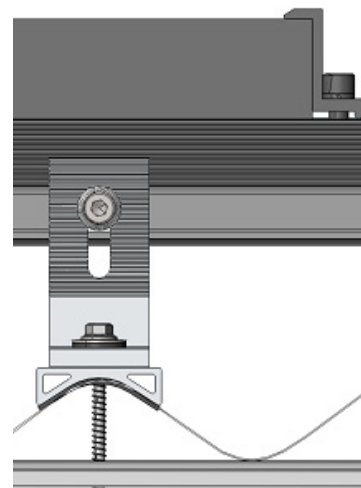

Clearance  
89~104mm

The rail is perpendicular to the Rib of metal sheet roof

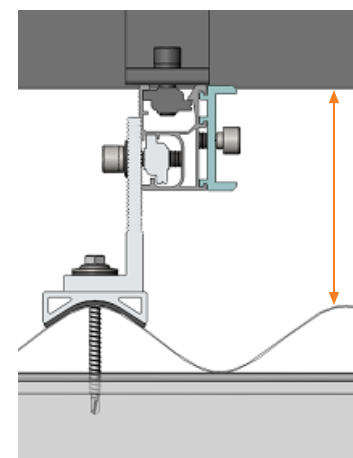

Clearance  
89~104mm

The rail is parallel to the Rib of metal sheet roof

## 5.5 Side Channel Cover for ECO-Rail Installation (optional)

After cables going into the side channel of ECO-Rail, click covers into side channel of ECO-Rail at the required places shown in Figures at the right side.

Notes:

1. Side channel cover is mill finish. It is recommended to use cutter rail (mill finish ECO-rail) as it will not require extra works earthing covers;
2. it is not recommended to uninstall covers as it could deform them due to very thin thickness;
3. When choosing side channel of ECO-rail for cables running, it is recommended to use ezclick tile or tin interface installation as it will make side channel full open.

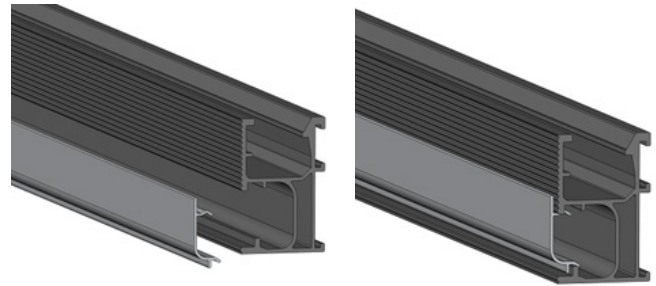

## 5.6 Hanger Bolt Installation

### 5.6.1 Hanger Bolt for Tile Roof Installation

Hanger bolt (ER-HB-8/150) installation on tile roof is only applicable for tile having some part of flat surface, where the rubber seal of hanger bot can mount flush on the tile not to cause waterproof problem.

Please note it is installer's responsibility to verify feasibility of tile brackets penetration and to ensure tiles are not cracked and damaged in hanger bolt installation.

5.6.1.1 Purlins are to be identified when opening tiles and their positions are marked out on the tiles.

5.6.1.2 Based on installation plan and Hanger bolt spacing info., hanger bolt locations are marked on the tiles.

Note:

Please find tin interface spacing in the certification letter for hanger bolt spacing.

5.6.1.3 Drill 10 mm hole on the marked location of tile and stop when reaching the purlins.

Note:

For some installations, it needs to drill through two tiles (overlap) to reach the purlin;

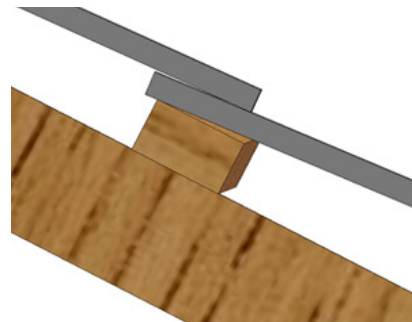
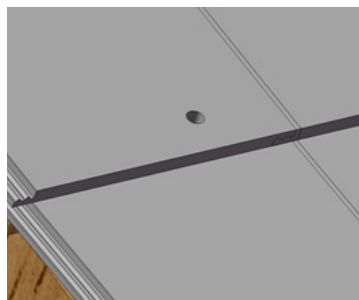

# Installation Instruction

5.6.1.4 Through 10 mm hole on the tiles, pre-drill 6 mm hole on the wood purlin for hanger bolt. The tiles are not removed when drilling this hole. After the drilling, clean the dust around 10 mm hole.

5.6.1.5 Adjust the position of rubber seal on the hanger bolt (ER-HB-8/150) to ensure hanger bolt have minimum 25 mm penetration depth into the wood purlin.

Drive the hanger bolt on the wood purlin till the rubber seal is firmly flush on the tile and turn the nut down till touching the rubber seal. Please turn another 4 threads cycle to press the rubber seal.

Note:

- 1) Purlin thickness and tile thickness need to be verified to decide position of rubber seal for appropriate penetration depth;
- 2) It is recommended to apply Sikaflex on the area around 10 mm hole of the tile before fixing hanger bolt. Please refer Sikaflex instructions for use.

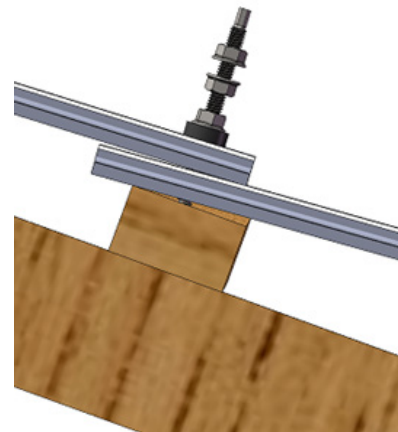
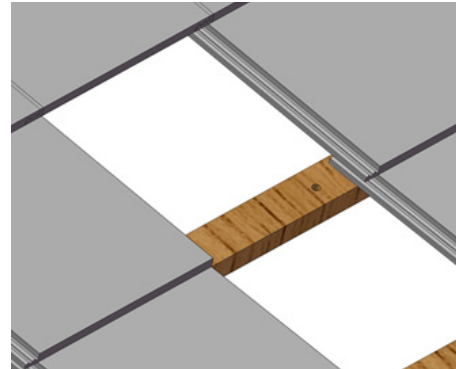

5.6.1.6 Screw out the top nut of hanger bolt, connect and adjust tin foot position and tighten the top nut with the recommended torque of 16~20 N·m.

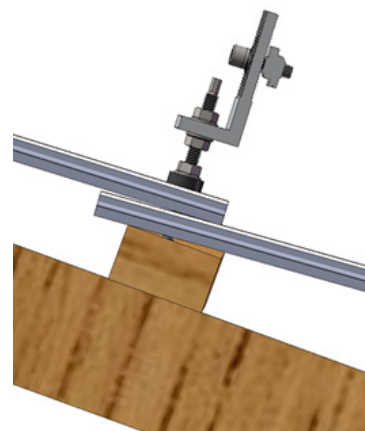
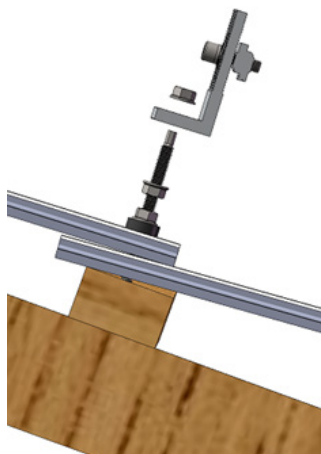

# Installation Instruction

Follow sections 5.2 and 5.3 to install the Rails and PV Modules.

## 5.6.2 Hanger Bolt for Tin Roof Installation

5.5.2.1 Hanger Bolt for wood purlin Installation  
Hanger bolt (ER-HB-8/150) installation on tin roof is recommended for trapezoidal profile of roof or similar one having flat surface on the rib.

Drill 11 mm hole on the marked location of roof sheet according to installation plan.

Through 11 mm hole on the roof sheet, pre-drill 6 mm hole on the wood purlin for hanger bolt.

Adjust the position of rubber seal on the hanger bolt (ER-HB-8/150) to ensure hanger bolt have minimum 25 mm penetration depth into the wood purlin.

Drive the hanger bolt on the wood purlin till the rubber seal is firmly flush on the tin roof sheet and turn the nut down till touching the rubber seal. Please turn another 4 threads cycle to press the rubber seal.

Note:

- 1) Penetration depth into the wood purlin is used to decide position of rubber seal;
- 2) It is recommended to apply Sikaflex on the area around 11 mm hole of tin roof before fixing hanger bolt. Please refer Sikaflex instructions for use.
- 3) The roof sheet should not have visible deformation after hanger bolt installation.

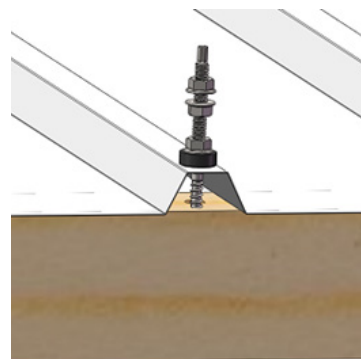
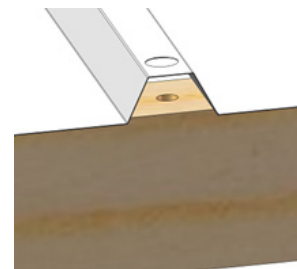
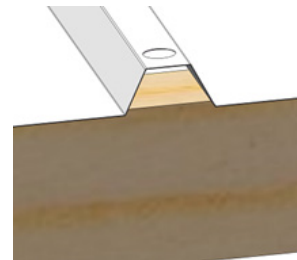

# Installation Instruction

Screw out the top nut of hanger bolt, connect and adjust tin foot position and tighten the top nut with the recommended torque of 16~20 N·m

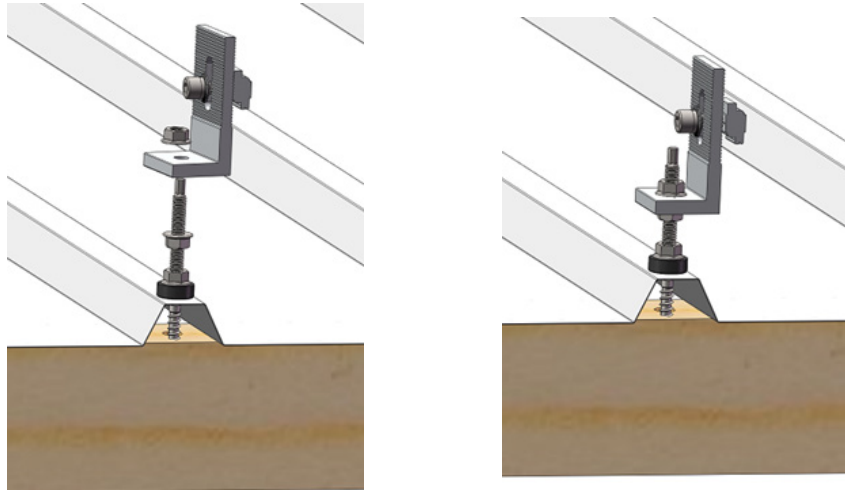

Follow sections 5.2 and 5.3 to install the Rails and PV Modules.

## 5.6.2.2 Hanger Bolt for metal purlin Installation

Hanger bolt (ER-HB-MP/8/150EP) installation on tin roof is recommended for trapezoidal profile of roof or similar one having flat surface on the rib.

Drill 11 mm hole on the marked location of roof sheet according to installation plan.

Through 11 mm hole on the roof sheet, pre-drill 6 mm hole on the metal purlin for hanger bolt.

Drive the hanger bolt (ER-HB-MP/8/150EP) on the metal purlin till the rubber seal is firmly flush on the tin roof sheet and turn the nut down till touching the rubber seal. Please turn another 4 threads cycle to press the rubber seal.

Note:

- 1) It is recommended to apply Sikaflex on the area around 11 mm hole of tin roof before fixing hanger bolt. Please refer Sikaflex instructions for use.
- 2) The roof sheet should not have visible deformation after hanger bolt installation.

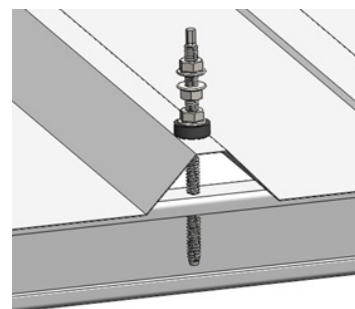
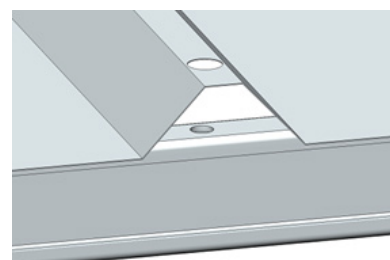

# Installation Instruction

Screw out the top nut of hanger bolt, connect and adjust tin foot position and tighten the top nut with the recommended torque of 16~20 N·m.

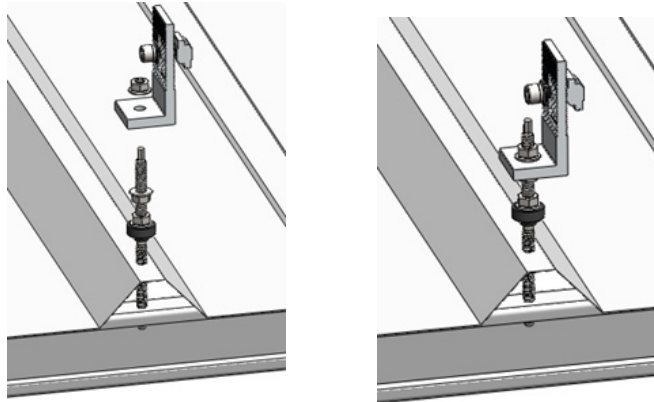

Follow sections 5.2 and 5.3 to install the Rails and PV Modules.

## 5.7 Roof Hook Extender Installation

### 5.7.1 Roof Hook Extender with Tile Interface Installation

Install the roof hook extender with Tile Interface as shown in the figures on the right.

Either use circular hole or elongated hole of roof hook extender to connect with Tile Interface is allowed.

Recommended torque of M8 bolt is 16~20N·m

Follow sections 5.2 and 5.3 to install the Rails and PV Modules.



Tile Interface connection with circular hole



Tile Interface connection with elongated hole



# Installation Instruction

## 5.7.2 Roof Hook Extender with Tin Interface Installation

Install the Roof hook Extender with L feet as shown in the figure on the right.

Either use circular hole or elongated hole of roof hook extender to connect with Tin Interface is allowed.

Recommended torque of M8 bolt is 16~20N·m

Follow sections 5.2 and 5.3 to install the Rails and PV Modules.



Tin Interface connection with circular hole



Tin Interface connection with elongated hole

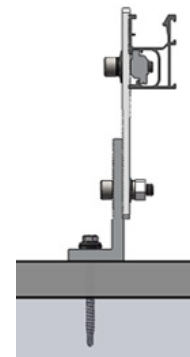

## 5.8 Accessory Installation

### 5.8.1 Isolator Shade Installation - To be Fixed along the Rail

Assemble the Isolator Shade step by step as shown in the figure on the right.

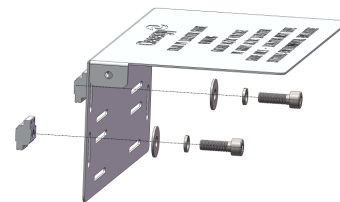

Recommended torque for M6 bolts is 4-5N·m, which allows for optimal opening and closing of the isolator cover.

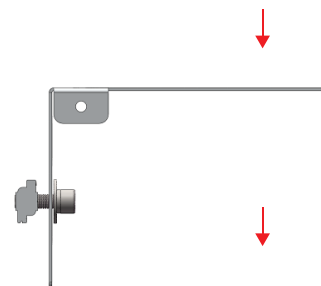

Note: When using Isolator Shade (black anodized), please apply External Teeth Lock Washers between Plain washer for earthing continuity.

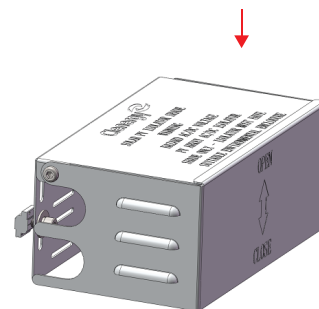
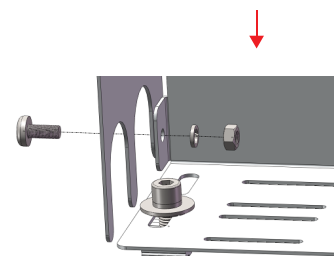
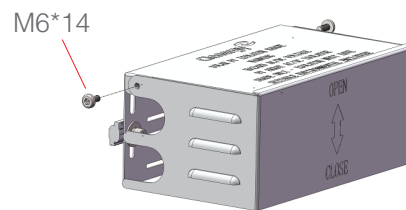

# Installation Instruction

According to your plan, mark out the position for Isolator Shade installation on the Rail.

Note: Allow space above the Rail for the Isolator Shade Cover to open fully

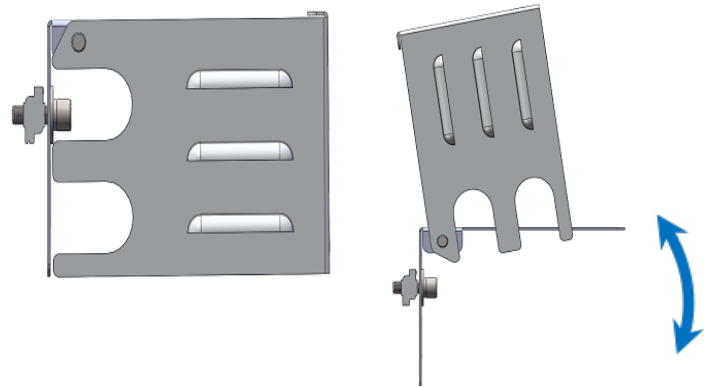

Rotate up the Cover and fix the Isolator to the Isolator Shade according to the Isolator Installation Guide

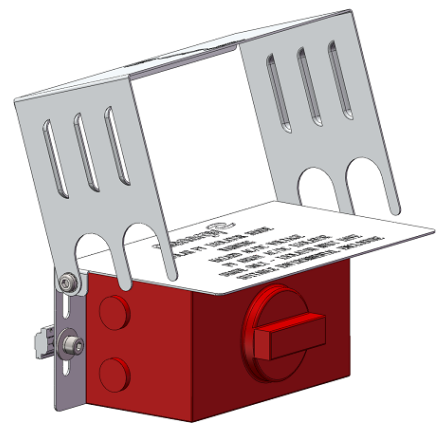

Once the Isolator is fixed properly, position the Z Module in the Rail channel and fix the Isolator Shade with the bolts supplied.

Recommended torque for M8 bolts is 4-5 N·m.

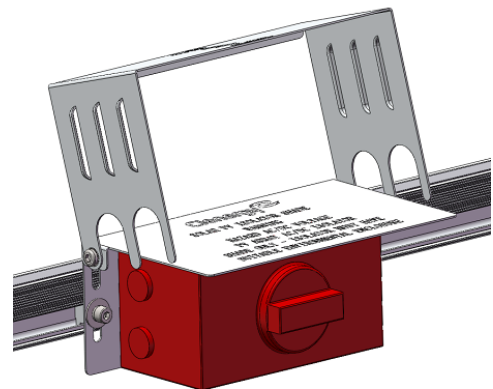

# Installation Instruction

After cable installation, close the Isolator Cover as shown in the figure on the right.

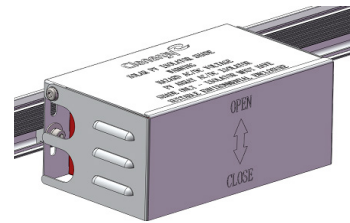

- To be Fixed Rail End (Optional)

An alternative option for fixing the Isolator Shade is at the end of the rail using the Angle Bracket as below,

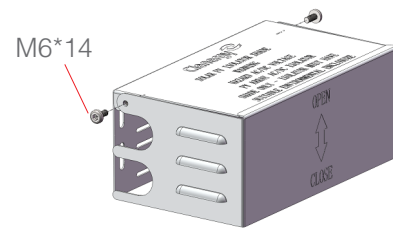

Assemble the Isolator Shade step by step as shown in the Figure on the right.

Recommended torque for M6 bolts is 4-5N·m, which allows for optimal opening and closing of the isolator cover.

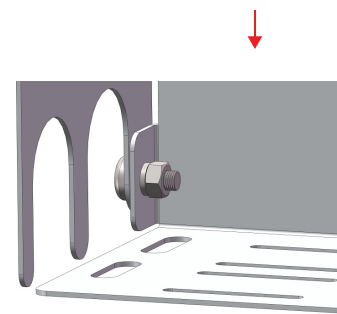

Note: When using Isolator Shade (black anodized), please apply External Teeth Lock Washers between Plain washer for earthing continuity.

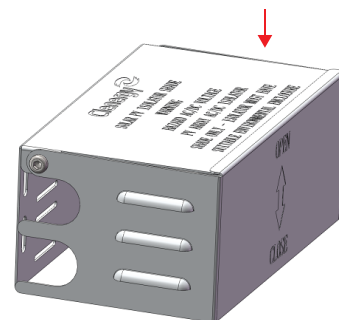

Rotate up the Cover and fix the Isolator to the Isolator Shade according to the Isolator Installation Guide in the Figure on the right.

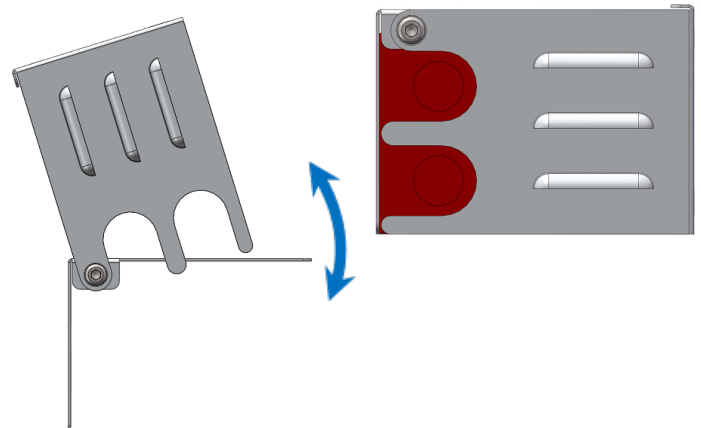

# Installation Instruction

Fix the Angle Bracket to the Isolator Shade and then fix the assembled Isolator Shade on the Rail as shown in the Figure on the right.

Note: Allow space above the Rail for the Isolator Shade Cover to open fully.

Recommended torque for M8 Bolts for fixing Angle Bracket on Isolator Shade is 8-10N·m.

Recommended torque for M8 Bolt for fixing Isolator Shade on the Rail is 16-20N·m.

After cable installation, close the Isolator Cover as shown in the Figure on the right.

## 5.8.2 Cable Clip Installation

- Click the top end of the Cable Clip into the channel on the back of the rail.
- Push the other end of the clip in to the rail channel, using a rubber mallet if required.

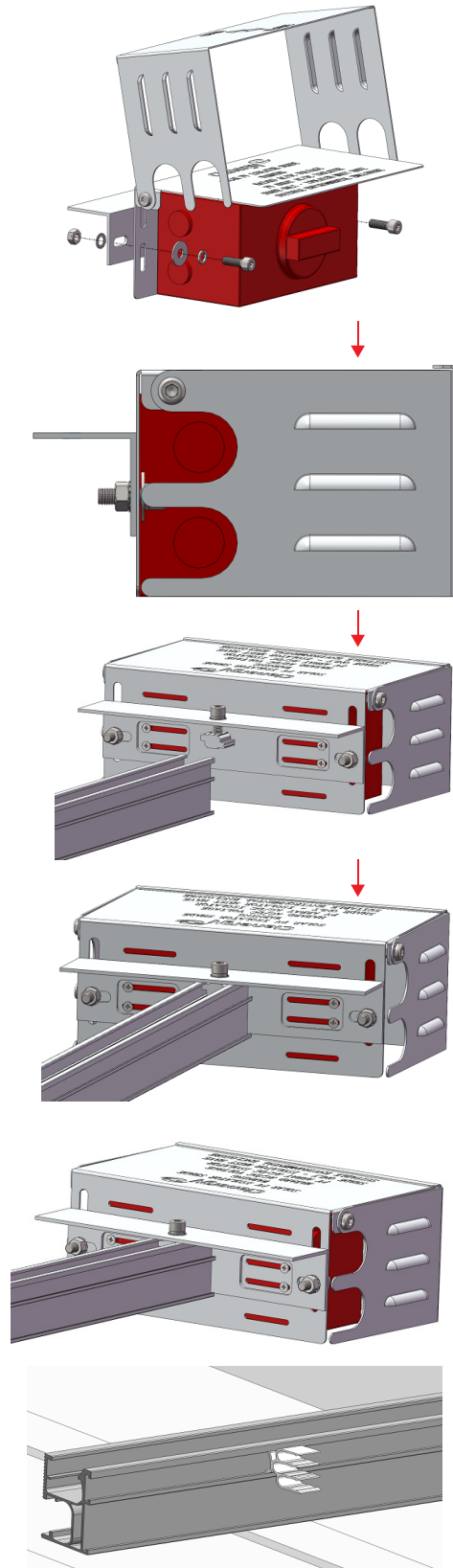

# Certification Letter and Interface Spacing Table



30 August 2020

Clenergy Australia  
1/10 Duerdin Street  
Clayton, VIC 3168

## CERTIFICATION LETTER

Clenergy PV-ezRack Solar Roof Certification – TC2, 2.5, 3 – Wind Region A, B, C, D. Internal REF: **00115**.  
Project REF: **CL-10088-SM-REV-G**.

MW Engineering Melbourne, being Structural Engineers within the meaning of Australian regulations, have calculated the maximum spacings for the PV ez-Rack rail system for the following conditions:

- **Wind Loads to AS 1170.2-2011 AMDT 4-2016**
  - o **Wind Terrain Category 2, 2.5 and 3**
  - o **Wind average recurrence of 200 years**
  - o **Wind Region A, B, C, D**
- **Solar panel length up to 2.2m**
- **Solar panel width up to 1.2m**

Attached are the tables showing the spacings according to Wind Region, roof pitch, and building height.

The values shown on these tables will be valid unless an amendment is issued on any of the following codes:

- |  |                           |
|--|---------------------------|
| - <b>AS/NZS 1170.0- 2002 AMDT 4-2016</b> | <b>General Principles</b> |
| - <b>AS/NZS 1170.1- 2002 AMDT 4-2016</b> | <b>Imposed Loadings</b>   |
| - <b>AS/NZS 1170.2- 2011 AMDT 4-2016</b> | <b>Wind Loadings</b>      |
| - <b>AS/NZS 1664.1- 1997 AMDT 1:1999</b> | <b>Aluminium Code</b>     |

Should you have any queries, do not hesitate to contact us.

Best Regards,

Alberto Escobar  
Civil/Structural Engineer  
**BEng MIEAust NER**  
BRP EC 46542  
RPEQ 18759  
[info@mwengineering.melbourne](mailto:info@mwengineering.melbourne)

## **STRUCTURAL DESIGN CERTIFICATION**

# **PV-ezRack<sup>R</sup> SolarRoof tin and tile flush interface spacing tables according to AS/NZS 1170.2:2011 Amdt 4-2016 Within Australia Terrain Category 2, 2.5 & 3**

**Client: Clenergy Australia**

**REF: CL-10088-SM – REV G**

**Date: AUG 2020**

**Copyright: The concepts and information contained in this document are the property of MW Engineering Melbourne. Use or copying of this document in whole or in part without the written permission of MW Engineering Melbourne constitutes an infringement in copyright.**

**Limitation: This report has been prepared for the exclusive use of Clenergy Australia, and is subject to and issued in connection with the provisions of the agreement between MW Engineering Melbourne and Clenergy Australia. MW Engineering Melbourne accepts no liability or responsibility whatsoever for any use of or reliance upon this report by any third party other than Clenergy's clients.**

**Internal REF: 00115**

**Client: Clenergy Australia**

**Project: PV-ezRack SolarRoof tin and tile flush interface spacing tables**

**Australian Standards**

**AS/NZS 1170.0:2002 (R2016)**

**AS/NZS 1170.1:2002 (R2016)**

**AS/NZS 1170.2:2011 (R2016)**

**AS/NZS 1664.1:1997-Amdt 1:1999**

**General Principles**

**Imposed loadings**

**Wind Loadings**

**Aluminium**

**Wind Terrain Category: 2, 2.5 & 3**

**Wind average recurrence: 200 years**

**Designed: SM**

**Date: AUG -20**

**Disclaimer: From the date of publication onwards, any amendment made to any of the above-mentioned Standards will make this report outdated and a new one will have to be released, unless the amendment has no implications on this certificate.**

## Contents

ER-I-01 - T.C 2.....	4
ER-I-01 - T.C 2.5.....	6
ER-I-01 - T.C 3.....	8
ER-I-05 - T.C 2.....	10
ER-I-05 - T.C 2.5.....	12
ER-I-05 - T.C 3.....	14
<b>General Notes</b> .....	16
Standard screws shipped for tin and tile roof interfaces .....	16
Tin and tile reduction factors table for 0.75 mm thick steel battens and 1.2mm thick purlins.....	16
Tin increase factors table for 1.9 mm and 2.4 mm thick purlins.....	16
Timber batten embedment reduction factors table.....	16
Components table.....	17
Panel size reduction/increasing factors table .....	20
Tile interface reduction factors table.....	21
Universal tile interface reduction factors table .....	22

## PV-ezRack SolarRoof Interface spacing tables

Type of Rail	ER-R-ECO (Refer to <a href="#">Note 7</a> for other compatible rails)
Type of Interface	ER-I-01 (Tile Interface)
Solar Panel Dimension	2 m x 1 m (Refer to <a href="#">Note 13</a> for other panel sizes)
Terrain Category	2

### Roof Angle - $0^\circ < \alpha \leq 10^\circ$

Wind Region	Building Height (m)									
	$H \leq 5$		$5 < H \leq 10$		$10 < H \leq 15$		$15 < H \leq 20$		$20 < H \leq 30$	
	U.W & D.W	Central	U.W & D.W	Central	U.W & D.W	Central	U.W & D.W	Central	U.W & D.W	Central
A	1488	1637	1444	1588	1369	1506	1354	1490	1310	1441
B	1086	1195	997	1097	893	982	819	900	700	769
C	692	761	647	712	566	622	513	565	454	499
D	417	458	402	442	365	401	327	360	290	319

### Roof Angle - $10^\circ < \alpha \leq 20^\circ$

Wind Region	Building Height (m)									
	$H \leq 5$		$5 < H \leq 10$		$10 < H \leq 15$		$15 < H \leq 20$		$20 < H \leq 30$	
	U.W & D.W	Central	U.W & D.W	Central	U.W & D.W	Central	U.W & D.W	Central	U.W & D.W	Central
A	1459	1604	1415	1556	1342	1476	1327	1460	1284	1412
B	1065	1171	977	1075	875	963	802	882	686	754
C	678	746	634	698	554	610	503	554	445	489
D	408	449	394	433	357	393	321	353	284	313

### Roof Angle - $20^\circ < \alpha \leq 30^\circ$

Wind Region	Building Height (m)									
	$H \leq 5$		$5 < H \leq 10$		$10 < H \leq 15$		$15 < H \leq 20$		$20 < H \leq 30$	
	U.W & D.W	Central	U.W & D.W	Central	U.W & D.W	Central	U.W & D.W	Central	U.W & D.W	Central
A	1444	1588	1400	1540	1328	1461	1314	1445	1270	1397
B	1054	1159	967	1064	866	953	794	873	679	746
C	671	738	628	691	549	603	498	548	440	484
D	404	445	390	429	354	389	318	349	282	310

## PV-ezRack SolarRoof Interface spacing tables (Cont.)

Type of Rail	ER-R-ECO (Refer to <a href="#">Note 7</a> for other compatible rails)
Type of Interface	ER-I-01 (Tile Interface)
Solar Panel Dimension	2 m x 1 m (Refer to <a href="#">Note 13</a> for other panel sizes)
Terrain Category	2

### Roof Angle - $30^\circ < \alpha \leq 60^\circ$

Wind Region	Building Height (m)									
	$H \leq 5$		$5 < H \leq 10$		$10 < H \leq 15$		$15 < H \leq 20$		$20 < H \leq 30$	
	U.W & D.W	Central	U.W & D.W	Central	U.W & D.W	Central	U.W & D.W	Central	U.W & D.W	Central
A	1414	1555	1371	1509	1301	1431	1287	1415	1244	1369
B	1032	1135	947	1042	848	933	778	855	665	731
C	657	723	615	677	537	591	488	537	431	474
D	396	435	382	420	346	381	311	342	276	303

## PV-ezRack SolarRoof Interface spacing tables

Type of Rail	ER-R-ECO (Refer to <a href="#">Note 7</a> for other compatible rails)
Type of Interface	ER-I-01 (Tile Interface)
Solar Panel Dimension	2 m x 1 m (Refer to <a href="#">Note 13</a> for other panel sizes)
Terrain Category	2.5

### Roof Angle - $0^\circ < \alpha \leq 10^\circ$

Wind Region	Building Height (m)									
	$H \leq 5$		$5 < H \leq 10$		$10 < H \leq 15$		$15 < H \leq 20$		$20 < H \leq 30$	
	U.W & D.W	Central	U.W & D.W	Central	U.W & D.W	Central	U.W & D.W	Central	U.W & D.W	Central
A	1560	1717	1514	1665	1436	1579	1420	1562	1373	1511
B	1139	1253	1046	1150	936	1030	858	944	733	807
C	726	798	679	747	593	652	538	592	476	524
D	437	481	421	463	382	421	343	378	304	335

### Roof Angle - $10^\circ < \alpha \leq 20^\circ$

Wind Region	Building Height (m)									
	$H \leq 5$		$5 < H \leq 10$		$10 < H \leq 15$		$15 < H \leq 20$		$20 < H \leq 30$	
	U.W & D.W	Central	U.W & D.W	Central	U.W & D.W	Central	U.W & D.W	Central	U.W & D.W	Central
A	1529	1682	1483	1632	1407	1548	1392	1531	1346	1480
B	1116	1228	1025	1127	918	1009	841	925	719	791
C	711	782	665	732	581	639	528	580	466	513
D	428	471	413	454	375	412	336	370	298	328

### Roof Angle - $20^\circ < \alpha \leq 30^\circ$

Wind Region	Building Height (m)									
	$H \leq 5$		$5 < H \leq 10$		$10 < H \leq 15$		$15 < H \leq 20$		$20 < H \leq 30$	
	U.W & D.W	Central	U.W & D.W	Central	U.W & D.W	Central	U.W & D.W	Central	U.W & D.W	Central
A	1514	1665	1468	1615	1393	1532	1377	1515	1332	1465
B	1105	1215	1014	1116	908	999	833	916	711	783
C	704	774	658	724	575	633	522	574	462	508
D	424	466	409	450	371	408	333	366	295	325

## PV-ezRack SolarRoof Interface spacing tables (Cont.)

Type of Rail	ER-R-ECO (Refer to <a href="#">Note 7</a> for other compatible rails)
Type of Interface	ER-I-01 (Tile Interface)
Solar Panel Dimension	2 m x 1 m (Refer to <a href="#">Note 13</a> for other panel sizes)
Terrain Category	2.5

### Roof Angle - $30^\circ < \alpha \leq 60^\circ$

Wind Region	Building Height (m)									
	H ≤ 5		5 < H ≤ 10		10 < H ≤ 15		15 < H ≤ 20		20 < H ≤ 30	
	U.W & D.W	Central	U.W & D.W	Central	U.W & D.W	Central	U.W & D.W	Central	U.W & D.W	Central
A	1482	1631	1438	1582	1364	1500	1349	1484	1305	1435
B	1082	1190	993	1093	889	978	815	897	697	766
C	689	758	645	709	563	620	511	563	452	497
D	415	457	400	440	363	400	326	359	289	318

## PV-ezRack SolarRoof Interface spacing tables

Type of Rail	ER-R-ECO (Refer to <a href="#">Note 7</a> for other compatible rails)
Type of Interface	ER-I-01 (Tile Interface)
Solar Panel Dimension	2 m x 1 m (Refer to <a href="#">Note 13</a> for other panel sizes)
Terrain Category	3

### Roof Angle - $0^\circ < \alpha \leq 10^\circ$

Wind Region	Building Height (m)									
	$H \leq 5$		$5 < H \leq 10$		$10 < H \leq 15$		$15 < H \leq 20$		$20 < H \leq 30$	
	U.W & D.W	Central	U.W & D.W	Central	U.W & D.W	Central	U.W & D.W	Central	U.W & D.W	Central
A	1665	1832	1615	1777	1532	1685	1515	1667	1465	1612
B	1216	1337	1116	1227	999	1099	916	1008	783	861
C	774	852	724	797	633	696	575	632	508	559
D	466	513	450	495	408	449	366	403	325	357

### Roof Angle - $10^\circ < \alpha \leq 20^\circ$

Wind Region	Building Height (m)									
	$H \leq 5$		$5 < H \leq 10$		$10 < H \leq 15$		$15 < H \leq 20$		$20 < H \leq 30$	
	U.W & D.W	Central	U.W & D.W	Central	U.W & D.W	Central	U.W & D.W	Central	U.W & D.W	Central
A	1632	1795	1583	1741	1501	1652	1485	1634	1436	1580
B	1191	1311	1093	1203	979	1077	898	987	767	844
C	759	835	710	781	620	682	563	619	498	548
D	457	503	441	485	400	440	359	395	318	350

### Roof Angle - $20^\circ < \alpha \leq 30^\circ$

Wind Region	Building Height (m)									
	$H \leq 5$		$5 < H \leq 10$		$10 < H \leq 15$		$15 < H \leq 20$		$20 < H \leq 30$	
	U.W & D.W	Central	U.W & D.W	Central	U.W & D.W	Central	U.W & D.W	Central	U.W & D.W	Central
A	1615	1777	1567	1724	1486	1635	1470	1617	1422	1564
B	1179	1297	1082	1191	969	1066	888	977	759	835
C	751	826	703	773	614	675	557	613	493	542
D	452	498	436	480	396	435	355	391	315	346

## PV-ezRack SolarRoof Interface spacing tables (Cont.)

Type of Rail	ER-R-ECO (Refer to <a href="#">Note 7</a> for other compatible rails)
Type of Interface	ER-I-01 (Tile Interface)
Solar Panel Dimension	2 m x 1 m (Refer to <a href="#">Note 13</a> for other panel sizes)
Terrain Category	3

### Roof Angle - $30^\circ < \alpha \leq 60^\circ$

Wind Region	Building Height (m)									
	$H \leq 5$		$5 < H \leq 10$		$10 < H \leq 15$		$15 < H \leq 20$		$20 < H \leq 30$	
	U.W & D.W	Central	U.W & D.W	Central	U.W & D.W	Central	U.W & D.W	Central	U.W & D.W	Central
A	1582	1740	1535	1688	1455	1601	1440	1584	1392	1531
B	1155	1270	1060	1166	949	1044	870	957	744	818
C	736	809	688	757	601	661	546	600	483	531
D	443	487	427	470	388	426	348	383	308	339

## PV-ezRack SolarRoof Interface spacing tables

Type of Rail	ER-R-ECO (Refer to <a href="#">Note 7</a> for other compatible rails)
Type of Interface	ER-I-05 (Tin Interface)
Solar Panel Dimension	2 m x 1 m (Refer to <a href="#">Note 13</a> for other panel sizes)
Terrain Category	2

### Roof Angle - $0^\circ < \alpha \leq 10^\circ$

Wind Region	Building Height (m)									
	$H \leq 5$		$5 < H \leq 10$		$10 < H \leq 15$		$15 < H \leq 20$		$20 < H \leq 30$	
	U.W & D.W	Central	U.W & D.W	Central	U.W & D.W	Central	U.W & D.W	Central	U.W & D.W	Central
A	1579	1737	1496	1646	1469	1616	1432	1575	1377	1515
B	1368	1505	1157	1272	1047	1151	964	1060	900	990
C	890	980	734	808	670	737	624	687	588	646
D	542	596	506	556	431	475	395	434	367	404

### Roof Angle - $10^\circ < \alpha \leq 20^\circ$

Wind Region	Building Height (m)									
	$H \leq 5$		$5 < H \leq 10$		$10 < H \leq 15$		$15 < H \leq 20$		$20 < H \leq 30$	
	U.W & D.W	Central	U.W & D.W	Central	U.W & D.W	Central	U.W & D.W	Central	U.W & D.W	Central
A	1574	1732	1492	1641	1460	1606	1423	1565	1372	1510
B	1359	1495	1157	1272	1042	1146	955	1050	895	985
C	881	969	730	803	661	727	620	682	583	641
D	532	586	464	510	422	465	386	424	358	394

### Roof Angle - $20^\circ < \alpha \leq 30^\circ$

Wind Region	Building Height (m)									
	$H \leq 5$		$5 < H \leq 10$		$10 < H \leq 15$		$15 < H \leq 20$		$20 < H \leq 30$	
	U.W & D.W	Central	U.W & D.W	Central	U.W & D.W	Central	U.W & D.W	Central	U.W & D.W	Central
A	1570	1727	1487	1636	1460	1606	1418	1560	1368	1505
B	1359	1495	1148	1262	1037	1141	950	1045	890	980
C	877	964	725	798	661	727	620	682	583	641
D	532	586	464	510	422	465	386	424	353	389

## PV-ezRack SolarRoof Interface spacing tables (Cont.)

Type of Rail	ER-R-ECO (Refer to <a href="#">Note 7</a> for other compatible rails)
Type of Interface	ER-I-05 (Tin Interface)
Solar Panel Dimension	2 m x 1 m (Refer to <a href="#">Note 13</a> for other panel sizes)
Terrain Category	2

### Roof Angle - $30^\circ < \alpha \leq 60^\circ$

Wind Region	Building Height (m)									
	$H \leq 5$		$5 < H \leq 10$		$10 < H \leq 15$		$15 < H \leq 20$		$20 < H \leq 30$	
	U.W & D.W	Central	U.W & D.W	Central	U.W & D.W	Central	U.W & D.W	Central	U.W & D.W	Central
A	1561	1717	1469	1616	1423	1565	1386	1525	1359	1495
B	1331	1464	1102	1212	1010	1111	936	1030	872	959
C	863	949	707	778	597	656	615	677	578	636
D	532	586	459	505	413	454	376	414	349	384

## PV-ezRack SolarRoof Interface spacing tables

Type of Rail	ER-R-ECO (Refer to <a href="#">Note 7</a> for other compatible rails)
Type of Interface	ER-I-05 (Tin Interface)
Solar Panel Dimension	2 m x 1 m (Refer to <a href="#">Note 13</a> for other panel sizes)
Terrain Category	2.5

### Roof Angle - $0^\circ < \alpha \leq 10^\circ$

Wind Region	Building Height (m)									
	$H \leq 5$		$5 < H \leq 10$		$10 < H \leq 15$		$15 < H \leq 20$		$20 < H \leq 30$	
	U.W & D.W	Central	U.W & D.W	Central	U.W & D.W	Central	U.W & D.W	Central	U.W & D.W	Central
A	1671	1838	1616	1777	1561	1717	1487	1636	1469	1616
B	1460	1606	1359	1495	1221	1343	1111	1222	1010	1111
C	1001	1101	890	980	789	868	725	798	652	717
D	624	687	569	626	505	555	459	505	422	465

### Roof Angle - $10^\circ < \alpha \leq 20^\circ$

Wind Region	Building Height (m)									
	$H \leq 5$		$5 < H \leq 10$		$10 < H \leq 15$		$15 < H \leq 20$		$20 < H \leq 30$	
	U.W & D.W	Central	U.W & D.W	Central	U.W & D.W	Central	U.W & D.W	Central	U.W & D.W	Central
A	1666	1833	1611	1772	1551	1707	1478	1626	1460	1606
B	1450	1595	1359	1495	1216	1338	1106	1217	1005	1106
C	996	1096	881	969	780	858	725	798	643	707
D	620	682	565	621	500	550	450	495	418	459

### Roof Angle - $20^\circ < \alpha \leq 30^\circ$

Wind Region	Building Height (m)									
	$H \leq 5$		$5 < H \leq 10$		$10 < H \leq 15$		$15 < H \leq 20$		$20 < H \leq 30$	
	U.W & D.W	Central	U.W & D.W	Central	U.W & D.W	Central	U.W & D.W	Central	U.W & D.W	Central
A	1662	1828	1607	1767	1551	1707	1473	1621	1455	1601
B	1450	1595	1354	1489	1212	1333	1102	1212	1001	1101
C	987	1086	877	964	776	853	721	793	643	707
D	620	682	565	621	496	545	454	500	413	454

## PV-ezRack SolarRoof Interface spacing tables (Cont.)

Type of Rail	ER-R-ECO (Refer to <a href="#">Note 7</a> for other compatible rails)
Type of Interface	ER-I-05 (Tin Interface)
Solar Panel Dimension	2 m x 1 m (Refer to <a href="#">Note 13</a> for other panel sizes)
Terrain Category	2.5

### Roof Angle - $30^\circ < \alpha \leq 60^\circ$

Wind Region	Building Height (m)									
	$H \leq 5$		$5 < H \leq 10$		$10 < H \leq 15$		$15 < H \leq 20$		$20 < H \leq 30$	
	U.W & D.W	Central	U.W & D.W	Central	U.W & D.W	Central	U.W & D.W	Central	U.W & D.W	Central
A	1652	1818	1561	1717	1515	1666	1469	1616	1359	1495
B	1395	1535	1304	1434	1193	1313	1092	1202	964	1060
C	955	1050	863	949	771	848	716	788	643	707
D	615	677	551	606	487	535	441	485	404	444

## PV-ezRack SolarRoof Interface spacing tables

Type of Rail	ER-R-ECO (Refer to <a href="#">Note 7</a> for other compatible rails)
Type of Interface	ER-I-05 (Tin Interface)
Solar Panel Dimension	2 m x 1 m (Refer to <a href="#">Note 13</a> for other panel sizes)
Terrain Category	3

### Roof Angle - $0^\circ < \alpha \leq 10^\circ$

Wind Region	Building Height (m)									
	$H \leq 5$		$5 < H \leq 10$		$10 < H \leq 15$		$15 < H \leq 20$		$20 < H \leq 30$	
	U.W & D.W	Central	U.W & D.W	Central	U.W & D.W	Central	U.W & D.W	Central	U.W & D.W	Central
A	1744	1919	1735	1909	1671	1838	1597	1757	1450	1595
B	1528	1681	1524	1676	1423	1565	1285	1414	1148	1262
C	1102	1212	1092	1202	946	1040	845	929	753	828
D	689	757	679	747	606	666	532	586	468	515

### Roof Angle - $10^\circ < \alpha \leq 20^\circ$

Wind Region	Building Height (m)									
	$H \leq 5$		$5 < H \leq 10$		$10 < H \leq 15$		$15 < H \leq 20$		$20 < H \leq 30$	
	U.W & D.W	Central	U.W & D.W	Central	U.W & D.W	Central	U.W & D.W	Central	U.W & D.W	Central
A	1735	1909	1726	1898	1666	1833	1588	1747	1446	1590
B	1524	1676	1519	1671	1418	1560	1276	1404	1138	1252
C	1102	1212	1088	1197	936	1030	840	924	748	823
D	684	752	670	737	601	661	523	576	464	510

### Roof Angle - $20^\circ < \alpha \leq 30^\circ$

Wind Region	Building Height (m)									
	$H \leq 5$		$5 < H \leq 10$		$10 < H \leq 15$		$15 < H \leq 20$		$20 < H \leq 30$	
	U.W & D.W	Central	U.W & D.W	Central	U.W & D.W	Central	U.W & D.W	Central	U.W & D.W	Central
A	1680	1848	1662	1828	1597	1757	1524	1676	1377	1515
B	1515	1666	1423	1565	1368	1505	1248	1373	1102	1212
C	1203	1323	1065	1171	918	1010	826	909	725	798
D	776	853	652	717	588	646	514	565	450	495

## PV-ezRack SolarRoof Interface spacing tables (Cont.)

Type of Rail	ER-R-ECO (Refer to <a href="#">Note 7</a> for other compatible rails)
Type of Interface	ER-I-05 (Tin Interface)
Solar Panel Dimension	2 m x 1 m (Refer to <a href="#">Note 13</a> for other panel sizes)
Terrain Category	3

### Roof Angle - $30^\circ < \alpha \leq 60^\circ$

Wind Region	Building Height (m)									
	$H \leq 5$		$5 < H \leq 10$		$10 < H \leq 15$		$15 < H \leq 20$		$20 < H \leq 30$	
	U.W & D.W	Central	U.W & D.W	Central	U.W & D.W	Central	U.W & D.W	Central	U.W & D.W	Central
A	1671	1838	1662	1828	1597	1757	1524	1676	1377	1515
B	1441	1585	1423	1565	1368	1505	1248	1373	1102	1212
C	1074	1181	1065	1171	918	1010	826	909	725	798
D	661	727	652	717	588	646	514	565	450	495

## General Notes

**Note 1.** Tile Roof Interface Spacing tables based on a minimum depth into F7 (Pine) timber of 25mm and Tin Roof Interface Spacing tables based on a minimum depth into F7 (Pine) timber of 35mm and Steel Purlins G450 1.5mm thick.

**Note 2.** Standard screws shipped for tin and tile Roof Interfaces

Metal Purlins/Battens	Fasteners to use
0.75 mm	Buildex- 14 - 11 x 70 Hex Head Zips Climaseal 3 with 16 mm ABW on G550 Steel Battens
1.5 mm - 2.4 mm	Buildex- 14 - 11 x 70 Hex Head Zips Climaseal 3 with 16 mm ABW
Wood Purlins and Rafters	Fasteners to be used
Timber F7 (Pine) and Timber I7 (Hardwood).	<b>Tin Interface:</b> Buildex- 14 - 11 x 70 Hex Head Zips Climaseal 3 with 16 mm ABW or 14g (6.3 mm)
	<b>Tile Interface:</b> Buildex- 14 - 11 x 70 Hex Head Zips Climaseal 3 with 16 mm ABW or 14-10 x 50 Hex Head T17 with 16mm ABW Climaseal 3 or 14-10 x 65 Hex Head T17 Climaseal 3 or other screw of pullout value not less than screws above.

**Note 3.** Tin and tile spacings were calculated based on Steel Purlins G450 1.5mm and Timber F7 (Pine). For 0.75 mm thick steel battens and 1.2mm thick purlins, all the fixing spacings shall be reduced as follows:

Wind Region A	Wind Region B	Wind Region C	Wind Region D
- 28 %	- 40 %	- 40 %	- 40 %

**Note 4.** For 1.9 mm and 2.4 mm thick purlins, all the fixing spacings shall be increased as follows:

Wind Region A	Wind Region B	Wind Region C	Wind Region D
-	-	+ 5 %	+ 10 %

**Note 5.** If reducing screw embedment by using EZ-AD-C43 adaptor or if attaching to a smaller timber batten/purlin, fixing spacing to be reduced/increased to timber purlins as per below:

Batten type	Batten-Purlin Depth / Screw embedment	
	25 mm	30 mm
Timber F7	Reduction of 35%	Reduction of 25%
Timber F17	Spacings remain the same	Increase of 20%

**Note 6.** This engineering document was designed to cater for most common installation scenarios however, it does not cater for all of them. Contact Clenergy if you are unable to comply with any of the installation specifications listed on this document.

**Note 7.** The following components are satisfied for use according to AS/NZS 1664.1:1997-Amdt 1:1999 and AS/NZS 1170.2:2011 Amdt 4-2016

Components	Part No.	Description
ECO-Rail	ER-R-ECO/XXXX	ECO Rail
Splice	ER-SP-ECO	PV-ezRack Splice for ECO rail
Australian Made Mill Finish ECO Rail	R-ECO/XXXX/AUMF	PV-ezRack Australian Made Mill Finish ECO Rail
ST-Rail	ER-R-STXXXX	Standard Rail
Splice	ER-SP-ST	PV-ezRack Splice for Standard Rail 200mm
ECO Rail Black	ER-R-ECO/XXXX/BA	ECO Rail Black
Black Splice ECO Rail	ER-SP-ECO/BA	Splice ECO Rail Black
Inter Clamp	ER-IC-STXX	Inter Clamp = clamp + Z-Module + Bolt.
End Clamp	ER-EC-STXX	End Clamp = clamp + Z-Module + bolt
Clamp	C-U/30/46-G	Universal Clamp for Frame Height 30-46mm with Grounding Clip
Clamp	C-U/30/46	Universal Clamp for Frame Height 30-46mm
End Clamp	ER-EC-DU35/40	End Clamp dual 35 or 40mm
End Clamp	ER-EC-DU40/46	End Clamp dual 40 or 46mm
Inter Security Clamp	ER-IC-STXX/S	Inter Clamp = Clamp + Z-Module + Security Bolt
End Security Clamp	ER-EC-STXX/S	End Clamp = Clamp + Z-Module + Security Bolt

<b>Components</b>	<b>Part No.</b>	<b>Description</b>
Interface	ER-I-01, 02, 04, 23, 26 and 51	Tile Interface
Interface	ER-I-01/CS	Carbon Steel Tile Interface
Tile Interface with ezClick connection for ECO-Rail	ER-I-01/EZC/ECO	PV-ezRack SolarRoof, Tile Interface with ezClick connection for ECO-Rail
Interface	ER-I-05	Tin Interface
Black Interface	ER-I-05/BA	Black Tin Interface
Interface	ER-I-05/CM	Tin Interface with Click Module
Interface	ER-I-05A/EZC/ECO	ezClick connection for ECO-Rail
Interface	ER-I-25	Tin Interface with curved Base for corrugated Roof
Black Interface	ER-I-25/BA	Black Tin Interface with curved Base for corrugated Roof
End Clamp (*)	EC-FL/GE/XX/XX	End Clamp for Frameless Module (glued EPDM)
Inter Clamp (*)	IC-FL/GE/XX/XX	Inter Clamp for Frameless Module (glued EPDM)
End Clamp (*)	ER-EC-FL/XX/XX	End Clamp for Frameless Module
Inter Clamp (*)	ER-IC-FL/XX/XX	Inter Clamp for Frameless Module
Black End Clamp (*)	EC-FL/GE/XX/XX/B	Black End Clamp for Frameless Module (glued EPDM)
Black Inter Clamp (*)	IC-FL/GE/XX/XX/B	Black Inter Clamp for Frameless Module (glued EPDM)

Components	Part No.	Description
Adapter for Corrugated Roof	EZ-AD-C43	Adapted for Corrugated Iron Roof for Tin interface ER-I-05
Black Adapter for Corrugated Roof	EZ-AD-C43/BA	Black Adapted for Corrugated Iron Roof for Tin interface ER-I-05
Corrugated Adapter	EZ-AD-C110	PV-ezRack Adapter for Corrugated Iron Roof.
Roof Extender (Reduction Factor)	ER-RE-200	Roof Hook Extender, Suitable for ER-I-01,02,04,05,23,26, 51 and 01/CS
Connector Clamp	CRC-R/ECO-ZBW	Cross Connector Clamp for ECO-Rail
Hanger Bolt	ER-HB-10/200A	PV-ezRack, Hanger Bolt M10*200mm
Hanger Bolt	ER-HB-MP/8/150EP	PV-ezRack Hanger Bolt for metal purlin M8*150mm
Hanger Bolt	ER-HB-8/150	Hanger bolt without mounting plate M8x150. Fixed to timber purlin only
Mid Clamp XX Black	ER-IC-STXXB	Inter Clamp XX Black
End Clamp XX Black	ER-EC-STXXB	End Clamp XX Black
Black Universal Clamp	C-U/30/46-BA	Black Universal Clamp
Black Universal Clamp	C-U/30/46-G-BA	Black Universal Clamp with grounding clip
Universal tile interface	ER-I-61/EZC/ECO	Universal tile interface

(\*) Subject to the panel manufacturer's installation guide.

**Note 8.** For Terrain Category (TC) definition, please refer to clause 4.2.1 of AS/NZS 1170.2:2011 (R2016).

**Note 9.** The installed frame must comply with the clamping zone of the PV Panel.

**Note 10.** Capacities checked and compared against testing data from Clenergy Australia and MTS (NATA certified).

**Note 11.** Maximum permitted rail overhang of 40%.

**Note 12.** For the definition of roof zones, refer to Appendix D6 of the AS/NZS 1170.2:2011 (R2016) standard.

**Note 13.** This Engineering report is based on 2 m x 1 m panels and two rails per panel. However, a percentage increase could be applied on all interface spacings as shown on the following table.

Number of rails per panel	Panel length / width (mm)	Spacing +/-
2 rails	$\leq 1700 / \leq 1100$	+ 8 %
3 rails	$\leq 1700 / \leq 1100$	+ 12 %
4 rails	$\leq 1700 / \leq 1100$	+ 15 %
2 rails	$\leq 2000 / \leq 1100$	0 %
3 rails	$\leq 2000 / \leq 1100$	+ 10 %
4 rails	$\leq 2000 / \leq 1100$	+ 12 %
2 rails	$\leq 2100 / \leq 1100$	- 10 %
3 rails	$\leq 2100 / \leq 1100$	+ 6 %
4 rails	$\leq 2100 / \leq 1100$	+ 10 %
2 rails	$\leq 2200 / \leq 1100$	- 13 %
2 rails	$\leq 2200 / \leq 1200$	- 20 %

**Note 14.** From the date of publication onwards, any amendment made to any of the above-mentioned Standards will make this report outdated and a new one will have to be released, unless the amendment has no implications on this certificate.

**Note 15.** No consideration has been taken on the effect that the solar panel will have over the roof structure. It has been assumed that the roof will be able to resist the additional loadings imposed by the installation of the solar panels in conjunction with the Clenergy Mounting System.

**Note 16.** All components from Clenergy must be installed according to manufacturer's specification and the instructions shown in the relevant installation manual. Please check the Clenergy Australia website or contact them for access to the most recent installation manuals.

**Note 17.** No consideration has been taken on the effect of snow loads. In case the roof is located in a snow prone area, a special design must be made.

**Note 18.** This document does not cover the building frame capacity. It has been assumed that the building frame will be able to resist the additional loadings imposed by the installation of the solar panels in conjunction with the Clenergy mounting system.

**Note 19.** Neither Clenergy nor MW Engineering Melbourne are not to be responsible for external factors leading to compression of the tile interfaces.

**Note 20.** Topographic Multiplier (Mt) taken as 1.0. Refer to clause 4.4 of AS/NZS 1170.2:2011 (R2016) for more information.

**Note 21.** Shielding Multiplier (Ms) taken as 1.0. Refer to clause 4.3 of AS/NZS 1170.2:2011 (R2016) for more information.

**Note 22.** Wind Direction Multiplier (Md) taken as 1.0. Refer to clause 3.3 of AS/NZS 1170.2:2011 (R2016) for more information.

**Note 23.** General conditions

**Note 23.1** Minimum grade for steel purlins/battens of 450 Mpa.

**Note 23.2** Timber Grade members: F7 (Pine) and F17 (Hardwood).

**Note 23.3** If any of the screws of the interfaces go into pre-existing holes, they will have to be one size up compared to the screws that were previously installed. This is to ensure that the pullout capacity remains the same or higher.

**Note 24.** Spacings on tile interfaces will be reduced as follows:

Interface	% of Reduction
ER-I-01/CS, ER-I-51 & ER-I-01/EZC/ECO	-
ER-I-02	-50%
ER-I-04	-50%
ER-I-23	-28%
ER-I-26	-28%

**Note 25.** A minimum of two (2) screws per Tile Interface will be required for installation.

**Note 26.** For installations on the Central Zone increase ER-I-01 & ER-I-05 Interface Spacings by 10%.

**Note 27.** Use the same spacing listed on the tables of this certificate for panels installed in landscape.

**Note 28.** When using Roof Extender (ER-RE-200), reduce interface spacings by 15% on Wind Region A and B and 30% on Wind Region C and D.

**Note 29.** Conditions for flush mounted systems installed on flat and pitched roofs according to the D6 Appendix of the AS/NZS 1170.2:2011 (R2016).

- Roof pitch to be between 1° and 30°.
- $h/d \leq 0.5$  and  $h/b \leq 0.5$ . Being  $h$ = height,  $b$ = width and  $d$ = length of the building as per the below picture.
- Gap between the underside of the panel and the roof to be no less than 50mm and no more than 300mm.

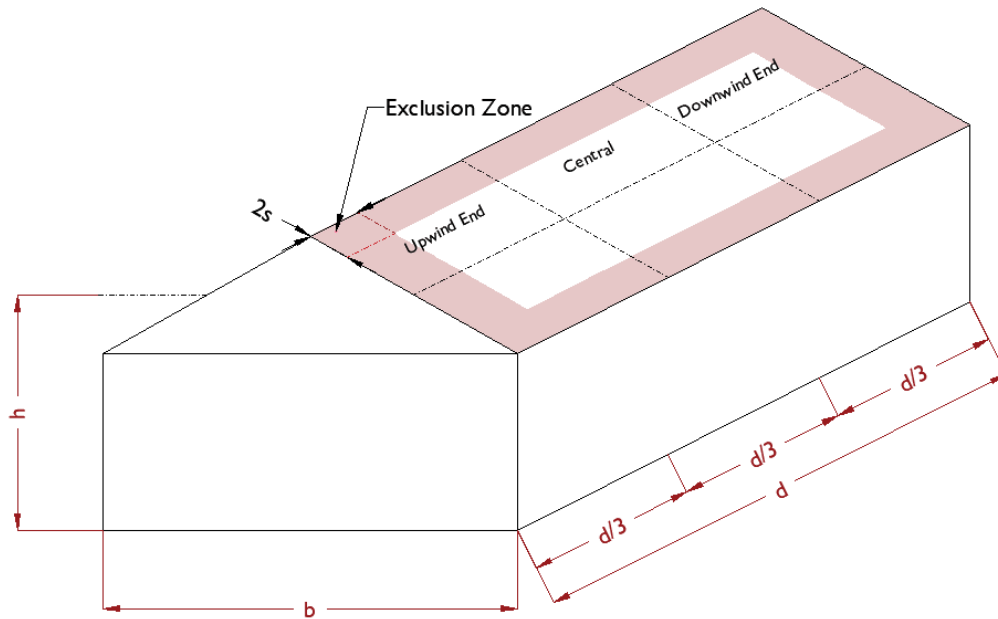

**Note 30.** Exclusion zone for flush installation to be the minimum distance from the edge of the roof "2s", where "s" is the gap between the underside of the panel and the roof.

**Note 31.** If the installation is located in ISO corrosivity category C4 reduce the interface spacing by 5%. If the installation is located in ISO corrosivity category C5 reduce the interface spacing by 25%.

**Note 32.** For ER-I-61/EZC/ECO, tile interface spacings shall be reduced as follows:

Wind Region A	Wind Region B	Wind Region C	Wind Region D
- 80 %	- 80 %	- 70 %	- 75 %

**Note 33.** Roof Zone definition when the installation doesn't meet the parameter on section D6 part (d) of the AS/NZS 1170.2:2011 (R2016) standard for roof angle is between 1° to 30°.

**Step 1.** Determine building height ( $h$ ), width ( $b$ ) and length ( $d$ ).

**Step 2.** Choose the lowest value between " $h$ ", " $b \times 0.2$ " and " $d \times 0.2$ ".

**Step 3.** The lowest value on Step 2, equates to  $a$ .

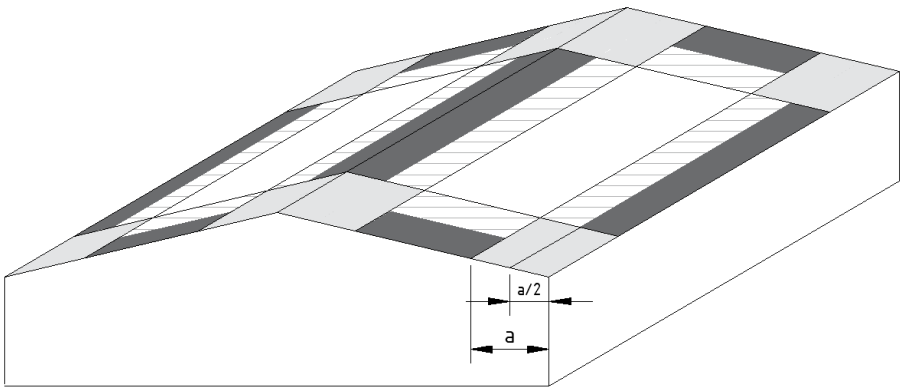

Roof Pitch < 10°

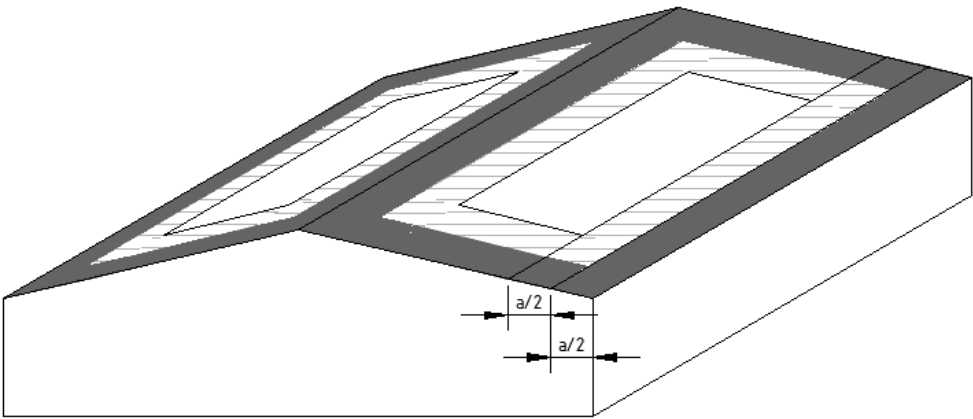



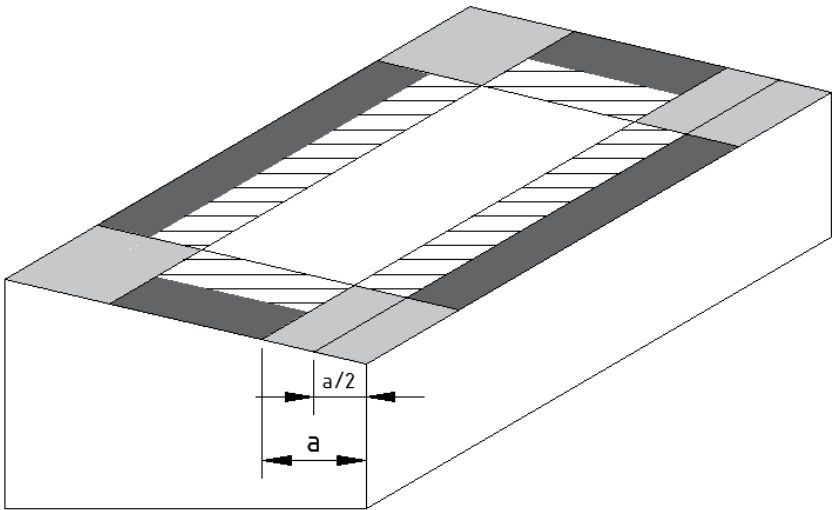

Roof Pitch ≥ 10°

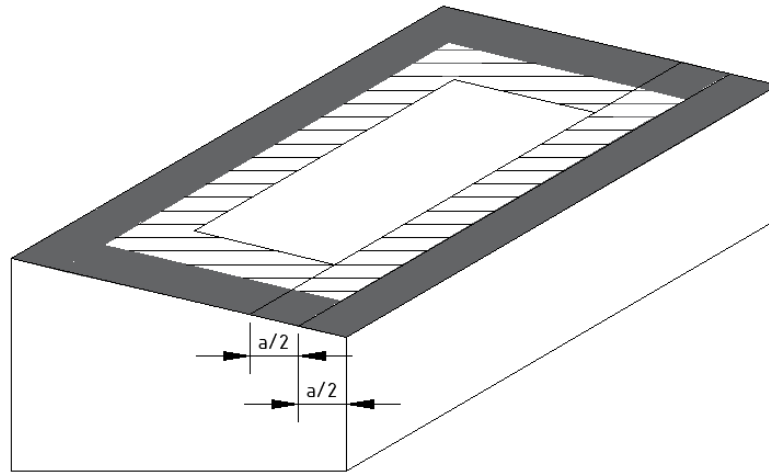

Flat/Mono – Slope Roof < 10°



**Legend:**

-  Internal Zone
-  Intermediate Zone
-  Edge Zone
-  Corner Zone

Flat/Mono – Slope Roof  $\geq 10^\circ$

**Note 34.** Zone reduction factors to be the following:

**Internal:** Use the same spacings as central zone.

**Intermediate:** Divide central zone spacings by 1.5.

**Edge:** Divide central zone spacings by 2.

**Corner:** Divide central zone spacings by 3.

**Note 35.** For Hanger Bolt installation on either tin or tile roof, the spacing to apply with a minimum embedment depth of 25mm into F7 (Pine) timber or fixing to metal purlin with 1.5 mm thickness is the same as the tin roof interface spacing (ER-I-05). The Hanger Bolts for wood purlin/rafter installation are ER-HB-8/150 and ER-HB-10/200A. The Hanger Bolt for metal purlin/rafter is ER-HB-MP/8/150EP.

**Note 36.** Neither Clenergy nor MW Engineering Melbourne will be responsible for the integrity of the roof tiles when using hanger bolts for the solar installation. It will be the clients' responsibility to check the hanger bolt installation feasibility.

Example when building parameters fall outside section D6 of the AS/NZS 1170.2:2011 (R2016) standard.

Tin roof

Wind Region A

Terrain Category: 3

Building height: 5m

Roof pitch: less than  $10^\circ$

Panel dimension: 2 m x 1 m

Installation on intermediate zone to be:

- Central spacing: 1919 mm
- Intermediate zone: 1279 mm

Reduction for corrosion category C4 (-5% - Note 31)

- Central spacing: 1820 mm
- Intermediate zone: 1215 mm



### Clenergy Australia

1/10 Duerdin Street, Clayton VIC 3168 Australia  
 Tel: +61 3 9239 8088 Fax: +61 3 9239 8024  
 E-mail: sales@clenergy.com.au  
[www.clenergy.com.au](http://www.clenergy.com.au)

### Clenergy China

999-1009 Min'an Rd, Huoju Hi-tech Ind. Dev. Zone  
 Xiang'an District 361101, Xiamen, Fujian, China  
 Tel: +86 592 311 0088 Fax: +86 592 599 5028  
 E-mail: sales@clenergy.com.cn  
[www.clenergy.com.cn](http://www.clenergy.com.cn)

### Clenergy EMEA

Esplanade 41, 20354 Hamburg, Germany  
 Tel: +49 (0) 40 3562 389 00  
 E-mail: sales.emea@clenergy.com

### Clenergy Japan

Nittochi Yamashita Building 5th Floor  
 23 Yamashita-cho, Yokohama, 231-0023 Japan  
 Tel: +81 45 228 8226 Fax: +81 45 228 8316  
 E-mail: sales@clenergy.co.jp  
[www.clenergy.jp](http://www.clenergy.jp)

### Clenergy Philippines

145 Yakal St., San Antonio village, Makati City, Philippines  
 Tel: +63 977 8407240  
 E-mail: sales\_ph@clenergy.com  
[www.clenergy.ph](http://www.clenergy.ph)

### Clenergy Thailand

9/2, 5th Floor, Vorasin Building, Soi Yasooob 2, Viphavadee-Rungsit  
 Road, Chomphon Sub-district, Chatuchak District, Bangkok 10900  
 Tel: +66 (0) 2 277 5201, +66 (0) 6 3228-0200  
 E-mail: sales\_th@clenergy.com, support\_th@clenergy.com  
[www.clenergythailand.com](http://www.clenergythailand.com)

### Clenergy Singapore

24 Raffles Place #28-01 Clifford Centre Singapore 048621  
 Tel: +65 9743 1425  
 E-mail: vincent.chan@clenergy.com

### Clenergy Malaysia

Tel: +86 18750231005  
 E-mail: sales\_em@clenergy.com

### Clenergy Vietnam

Tel: +86 592 3110095  
 E-mail: sales\_vietnam@clenergy.com;  
 susie.chen@clenergy.com

## Worldwide Network





Proposed  
EV  
Charger  
Installation  
Location

