



The storage and handling of flammable and combustible liquids



This Australian Standard® was prepared by Committee ME-017, Flammable and Combustible Liquids. It was approved on behalf of the Council of Standards Australia on 13 July 2017.

This Standard was published on 1 August 2017.

The following are represented on Committee ME-017:

- Australasian Fire and Emergency Service Authorities Council
- Australasian Institute of Dangerous Goods Consultants
- Australian Industry Group
- Australian Institute of Petroleum
- Australian Paint Manufacturers Federation
- Department of Defence
- Department of Justice, Tas.
- Department of Mines and Petroleum, WA
- Engineers Australia
- Fire Protection Association Australia
- Insurance Council of Australia
- Plastic and Chemicals Industries Association
- SafeWork SA
- WorkCover NSW
- Workplace Health and Safety, Qld
- WorkSafe, Vic.

Additional Interests:

- Accord Australasia
 - AusSpill Association
 - WorkCover Queensland
-

This Standard was issued in draft form for comment as DR AS 1940:2017.

Standards Australia wishes to acknowledge the participation of the expert individuals that contributed to the development of this Standard through their representation on the Committee and through the public comment period.

Keeping Standards up-to-date

Australian Standards® are living documents that reflect progress in science, technology and systems. To maintain their currency, all Standards are periodically reviewed, and new editions are published. Between editions, amendments may be issued.

Standards may also be withdrawn. It is important that readers assure themselves they are using a current Standard, which should include any amendments that may have been published since the Standard was published.

Detailed information about Australian Standards, drafts, amendments and new projects can be found by visiting www.standards.org.au

Standards Australia welcomes suggestions for improvements, and encourages readers to notify us immediately of any apparent inaccuracies or ambiguities. Contact us via email at mail@standards.org.au, or write to Standards Australia, GPO Box 476, Sydney, NSW 2001.

Australian Standard®

The storage and handling of flammable and combustible liquids

Originated as part of AS CB5—1942.
Previous edition AS 1940—2004.
Sixth edition AS 1940:2017.
Reissued incorporating Amendment No. 1 (August 2019).
Reissued incorporating Amendment No. 2 (June 2021).

COPYRIGHT

© Standards Australia Limited

All rights are reserved. No part of this work may be reproduced or copied in any form or by any means, electronic or mechanical, including photocopying, without the written permission of the publisher, unless otherwise permitted under the Copyright Act 1968.

PREFACE

This Standard was prepared by Standards Australia Committee ME-017, Flammable and Combustible Liquids, to supersede AS 1940—2004. The objective of this Standard is to promote the safety of persons and prevent damage to property and the environment where flammable or combustible liquids are stored or handled.

This Standard incorporates Amendment No. 1 (August 2019) and Amendment No. 2 (June 2021). The changes required by the Amendment are indicated in the text by a marginal bar and amendment number against the clause, note, table, figure or part thereof affected.

The changes in this revision of the Standard include alignment for the classification criteria of C1 combustible liquids to the Globally Harmonized System of Classification and Labelling of Chemicals (GHS). The use of plastic polyethylene or other composite polymeric tanks for the minor storage of combustible liquids is now permitted. Some changes to fire hydrants requirements were also made in Section 11, dealing with fire protection for package stores.

Committee ME-017 reviewed the report with recommendations into the Buncefield oil depot fire in Hertfordshire UK in 2005, and implemented engineering controls accordingly, wherever possible.

The terms ‘normative’ and ‘informative’ have been used in this Standard to define the application of the appendices to which they apply. A ‘normative’ appendix is an integral part of a Standard, whereas an ‘informative’ appendix is only for information and guidance.

Statements expressed in mandatory terms in notes to tables are deemed to be requirements of this Standard. Notes that appear in the main text of this Standard provide information only.

The series of Standards covering the storage and handling of Class 3 and related dangerous goods presently comprises the following Standards:

AS

1894	The storage and handling of non-flammable cryogenic and refrigerated liquids
2106	Methods for the determination of the flash point of flammable liquids (closed cup) (series)
2507	The storage and handling of agricultural and veterinary chemicals
2585	Determination of flash and fire points—Cleveland open cup method
2714	The storage and handling of organic peroxides
3780	The storage and handling of corrosive substances
3846	The handling and transport of dangerous cargoes in port areas
3961	The storage and handling of liquefied natural gas
4326	The storage and handling of oxidizing agents
4332	The storage and handling of gases in cylinders
4897	The design, installation and operation of underground petroleum storage systems
4976	The removal and disposal of underground petroleum storage tanks

AS/NZS	
1596	The storage and handling of LP Gas
2022	Anhydrous ammonia—Storage and handling
2927	The storage and handling of liquefied chlorine gas
3833	The storage and handling of mixed classes of dangerous goods, in packages and intermediate bulk containers
4081	The storage, handling and transport of liquid and liquefied polyfunctional isocyanates
4452	The storage and handling of toxic substances
4681	The storage and handling of Class 9 (miscellaneous) dangerous goods and articles
5026	The storage and handling of Class 4 dangerous goods
60079	Explosive atmospheres
60079.10.1	Part 10.1: Classification of areas—Explosive gas atmospheres
60079.14	Part 14: Electrical installations design, selection and erection

CONTENTS

	<i>Page</i>
SECTION 1 SCOPE AND GENERAL	
1.1 SCOPE.....	8
1.2 APPLICATION	8
1.3 NORMATIVE REFERENCES	9
1.4 DEFINITIONS.....	9
SECTION 2 MINOR STORAGE	
2.1 SCOPE OF SECTION	20
2.2 MINOR STORAGE QUANTITIES.....	20
2.3 PRECAUTIONS APPLYING TO MINOR STORAGE.....	26
2.4 MINOR STORAGE IN TANKS.....	27
SECTION 3 GENERAL REQUIREMENTS	
3.1 SCOPE OF SECTION	28
3.2 GENERAL DESIGN AND CONSTRUCTION REQUIREMENTS	28
3.3 MECHANICAL EQUIPMENT AND INSTALLATIONS.....	30
3.4 ELECTRICAL INSTALLATIONS AND EQUIPMENT.....	30
3.5 INTERNAL COMBUSTION ENGINES	30
3.6 LIGHTING	31
3.7 RESTRICTED USAGE	31
3.8 FIREWALLS AND VAPOUR BARRIERS.....	31
3.9 SECURITY, SIGNS AND NOTICES.....	32
3.10 TRANSIT STORAGE	32
3.11 IGNITION SOURCES.....	34
SECTION 4 PACKAGE STORAGE AND HANDLING AREAS	
4.1 SCOPE OF SECTION	35
4.2 TYPES OF STORES	35
4.3 LOCATION AND SEPARATION DISTANCES	39
4.4 CONSTRUCTION.....	43
4.5 VENTILATION.....	45
4.6 GENERAL REQUIREMENTS.....	51
4.7 STORAGE OF IBCs.....	51
4.8 STORAGE IN FREIGHT CONTAINERS.....	51
4.9 STORAGE IN STORAGE CABINETS	52
4.10 ACTIVITIES WITHIN PACKAGE STORES	54
4.11 OFFICES WITHIN PACKAGE STORES	54
SECTION 5 STORAGE IN TANKS	
5.1 SCOPE OF SECTION	55
5.2 GENERAL REQUIREMENTS.....	56
5.3 STORAGE TANK FILL POINTS	58
5.4 VENTING	59
5.5 EMERGENCY VENTING	63
5.6 LOCATION AND CAPACITY OF INDOOR TANKS	64
5.7 SEPARATION OF ABOVE-GROUND TANKS.....	65
5.8 BUNDS AND COMPOUNDS.....	68
5.9 REQUIREMENTS FOR ABOVE-GROUND TANKS WITH INTEGRAL SECONDARY CONTAINMENT.....	71

	<i>Page</i>
5.10 REQUIREMENTS FOR TANK CONTAINERS (ISO TANKS, PORTABLE TANKS) INCLUDING IBCs WHEN USED AS STATIC STORAGE TANKS	73
5.11 INSTALLATION METHODS FOR ABOVE-GROUND TANKS	73
5.12 INSTALLATION METHODS FOR UNDERGROUND TANKS	74
5.13 INSTALLATION METHODS FOR TANKS IN TANK CHAMBERS	75
5.14 SERVICE TANKS.....	76
SECTION 6 SYSTEMS FOR PIPING, VALVES, PUMPS AND TANK HEATING	
6.1 GENERAL DESIGN AND CONSTRUCTION	78
6.2 PIPING	78
6.3 VALVES	80
6.4 PUMPS.....	81
6.5 HEATING OF LIQUIDS	81
SECTION 7 FUEL DISPENSING	
7.1 SCOPE OF SECTION	83
7.2 GENERAL REQUIREMENTS.....	83
7.3 DISPENSERS.....	84
7.4 DELIVERY HOSES AND NOZZLES	86
7.5 MARINE DISPENSERS.....	86
7.6 OPERATIONS.....	87
SECTION 8 TANK VEHICLE LOADING FACILITIES	
8.1 SCOPE OF SECTION	89
8.2 GENERAL REQUIREMENTS.....	89
8.3 TOP-FILLING INSTALLATIONS.....	91
8.4 BOTTOM-LOADING FACILITIES.....	92
SECTION 9 OPERATIONAL AND PERSONNEL SAFETY	
9.1 SCOPE OF SECTION	94
9.2 GENERAL PRECAUTIONS.....	94
9.3 OPERATING PROCEDURES.....	97
9.4 MANAGEMENT OF ABOVE-GROUND LEAKS AND SPILLS	98
9.5 PLACARDING.....	100
9.6 LIQUID TRANSFER.....	100
9.7 EFFLUENT CONTROL	100
9.8 CONSTRUCTION AND MAINTENANCE WORK	100
9.9 GAS-FREEING OF TANKS AND PACKAGES.....	103
9.10 PERSONNEL TRAINING.....	103
9.11 RECORDS.....	104
9.12 PERSONAL PROTECTIVE EQUIPMENT (PPE)	105
9.13 FIRST AID	105
9.14 ADDITIONAL REQUIREMENTS FOR THE STORAGE AND HANDLING OF PACKAGES	106
9.15 ADDITIONAL REQUIREMENTS FOR PIPING AND VALVE SYSTEMS.....	108
9.16 ADDITIONAL REQUIREMENTS FOR PIPEWORK	108
9.17 ADDITIONAL REQUIREMENTS FOR TANKS	108
9.18 BULK TRANSFER	113

SECTION 10 EMERGENCY MANAGEMENT

10.1 SCOPE OF SECTION	116
10.2 PLANNING FOR EMERGENCIES	116
10.3 MANIFEST	117
10.4 PLACARDING.....	117

SECTION 11 FIRE PROTECTION

11.1 SCOPE OF SECTION	118
11.2 APPLICATION OF SECTION	118
11.3 GENERAL REQUIREMENTS FOR FIRE PROTECTION EQUIPMENT	118
11.4 PORTABLE FIRE EXTINGUISHERS.....	120
11.5 FIXED FIRE PROTECTION AND DETECTION SYSTEMS	121
11.6 FIRE EXTINGUISHER REQUIREMENTS FOR PRODUCT PUMPS, MANIFOLDS AND HOSE CONNECTION POINTS	123
11.7 FIRE EXTINGUISHER REQUIREMENTS FOR TANK VEHICLE TRANSFER AREAS	123
11.8 FIRE PROTECTION REQUIREMENTS FOR PACKAGE STORAGE AND HANDLING AREAS	124
11.9 FIRE PROTECTION REQUIREMENTS FOR FUEL DISPENSING INSTALLATIONS	127
11.10 FIRE PROTECTION REQUIREMENTS FOR ABOVE-GROUND FIRE-RATED TANKS, TANKS UNDERGROUND OR IN CHAMBERS.....	127
11.11 FIRE PROTECTION REQUIREMENTS FOR ABOVE-GROUND TANK STORAGE OF AGGREGATE CAPACITY LESS THAN 60 m ³	127
11.12 FIRE PROTECTION REQUIREMENTS FOR ABOVE-GROUND TANK STORAGE OF AGGREGATE CAPACITY 60 m ³ TO 2000 m ³	129
11.13 FIRE PROTECTION REQUIREMENTS FOR ABOVE-GROUND TANK STORAGE OF AGGREGATE CAPACITY 2000 m ³ AND GREATER.....	130
11.14 PIPING AND PUMPING SYSTEMS	132
11.15 COOLING WATER.....	133
11.16 FIXED FOAM SYSTEMS FOR TANKS	134

SECTION 12 WASTE STORAGE AND DISPOSAL

12.1 SCOPE OF SECTION	139
12.2 STORAGE OF WASTES	139
12.3 WASTE MANAGEMENT	139
12.4 WASTE DISPOSAL	139
12.5 PRE-DISPOSAL TREATMENT OF EMPTY CONTAINERS.....	139
12.6 METHODS OF DISPOSAL.....	140

APPENDICES

A LIST OF REFERENCED DOCUMENTS.....	141
B RECOMMENDATIONS FOR THE DESIGN AND CONSTRUCTION OF BLENDING PLANTS	145
C USE OF FORK-LIFT TRUCKS AND VEHICLES NOT RATED FOR HAZARDOUS AREAS IN FLAMMABLE LIQUIDS PACKAGE STORES	148
D RECOMMENDATIONS FOR THE STORAGE AND HANDLING OF PACKAGED FLAMMABLE LIQUIDS IN COOLROOMS.....	152
E ISSUES TO BE CONSIDERED IN A RISK ASSESSMENT.....	154
F STORAGE AND HANDLING OF POTABLE SPIRITS IN BULK	157
G POWER STATION AND GRID TRANSFORMERS	161
H TANK VENTING.....	162
I FIRE EXPOSURE PROTECTION	166

	<i>Page</i>
J COMBUSTION CHARACTERISTICS	170
K GAS-FREEING PRECAUTIONS AND PRINCIPLES	172
L RECOMMENDATIONS FOR BATCH BLENDING OF FLAMMABLE LIQUIDS	174
BIBLIOGRAPHY	177

STANDARDS AUSTRALIA

Australian Standard

The storage and handling of flammable and combustible liquids

SECTION 1 SCOPE AND GENERAL

1.1 SCOPE

This Standard sets out requirements and recommendations for the safe storage and handling of flammable liquids of dangerous goods Class 3, as classified in the UN *Recommendations for the Transport of Dangerous Goods—Model Regulations* and listed in the ADG Code. This Standard also provides requirements and recommendations for the storage and handling of combustible liquids, as defined in Clause 1.4.9.

This Standard provides minimum acceptable safety requirements for storage facilities, operating procedures, emergency planning and fire protection. It provides technical guidance that may assist in the storage and handling of flammable and combustible liquids in accordance with the risk management requirements of Safe Work Australia, Model Code of Practice, *Managing Risks of Hazardous Chemicals in the Workplace* and legislation which underpins that document.

This Standard provides requirements for commonly used flammable and combustible liquids such as hydrocarbons and industrial solvents. Some flammable and combustible liquids have other physical and chemical properties that require additional precautions and design considerations. Examples of these are—

- (a) liquids that can polymerize;
- (b) liquids that require blanketing with inert gas;
- (c) liquids that are heated; and
- (d) liquids that are assigned a subsidiary risk.

Any special precautions and considerations necessary for the safe storage and handling of such liquids are additional to the requirements and recommendations provided in this Standard.

For the storage and handling of dangerous goods of another class but having a Class 3 subsidiary risk, this Standard is relevant to their flammability aspects.

NOTE: Fuel blends that contain biofuel (e.g. ethanol) have physical and chemical properties that require additional precautions and design considerations.

1.2 APPLICATION**1.2.1 Where this Standard applies**

This Standard applies to the storage and handling of Class 3 dangerous goods as defined in Clause 1.4.8 or relevant legislation, with the exception of desensitized explosives of Class 3. It also applies to the storage and handling of combustible liquids. The requirements of this Standard apply in conjunction with, but do not take precedence over, any government legislation that applies in any area.

Where the flammable liquid being kept has one or more subsidiary risks, reference shall be made to the Australian Standards relevant to the Classes of those risks and the more stringent requirements shall apply. Where any combustible liquid being kept has risks of other Classes, the relevant Australian Standard for that Class shall be consulted, but for requirements relating to its combustible properties and fire safety, this Standard shall apply.

NOTE: It is often difficult to ascertain whether liquid in a drum or other package is a C1 or C2 combustible liquid. Only rarely do material safety data sheets (MSDS/SDS) indicate that a liquid is combustible. The actual classification can be determined by reference to the flash point (see Clause 1.4.29). If the flash point is not provided on the MSDS/SDS, it should be ascertained from the manufacturer or Australian supplier of the liquid.

This Standard applies in locations that are generally industrial, commercial or rural in nature, including laboratories where the provisions of this Standard are additional to those of AS 2243.10.

1.2.2 Where this Standard does not apply

This Standard does not apply to the following:

- (a) The transport of flammable liquids, which is covered by other regulations, rules and codes, e.g. the ADG Code, the International Maritime Dangerous Goods (IMDG) Code.
- (b) The handling of flammable liquids in port areas, where covered by AS 3846.
- (c) Shipboard installations.
- (d) The storage and handling of potable spirits having less than 24% v/v ethanol, and potable spirits with greater than 24% v/v ethanol in containers of less than 5 L capacity.
- (e) Residential-type heating oil installations comprising Category 1 tanks.
NOTE: Tank categories are described in Clause 1.4.7.
- (f) Liquefied gases that are maintained in the liquid phase for storage by means of pressure or refrigeration.
- (g) Fuel tanks of any mobile vehicle or equipment, including those on large mining vehicles.
- (h) Temporary field storages and associated facilities in remote locations for Australian Defence Force exercises or operations, or declared states of emergency.

1.3 NORMATIVE REFERENCES

The normative documents referred to in this Standard are listed in Appendix A.

NOTE: Documents referenced for informative purposes are listed in the Bibliography.

1.4 DEFINITIONS

For the purpose of this Standard, the definitions below apply.

1.4.1 Access

A means by which a person or vehicle can approach or leave a specific location. The term includes walkways, platforms, stairways, ladders, roads and all provisions for safe entry and exit.

1.4.2 ADG Code

The Australian Code for the Transport of Dangerous Goods by Road and Rail.

1.4.3 Boundary

The perimeter of the whole of the site under the same occupancy as the storage area.

1.4.4 Bulk

In relation to dangerous goods, dangerous goods which are not in packages.

1.4.5 Bund

An embankment or wall which may form part or all of the perimeter of a compound.

1.4.6 Capacity

1.4.6.1 General

The maximum volume or space within a container or compound.

NOTE: The normal capacity of a container is less than its full capacity, to allow for ullage or vapour expansion.

1.4.6.2 Normal fill level (normal capacity)

The maximum level to which the tank will intentionally be filled on a routine basis, using the normal process control system. It is sometimes referred to as the safe fill level.

1.4.6.3 Tank rated capacity

The level below the overfill level that will allow time for any action necessary to prevent the maximum capacity from being reached/exceeded.

1.4.6.4 Tank capacity (overfill level)

The point at which either the tank will suffer mechanical damage or product will be lost from the tank.

1.4.7 Category of tank

That category of a tank, as classified in AS 1692 and includes tanks constructed of materials other than steel, as follows:

- (a) *Category 1*—Tanks of up to 1200 L capacity, for aboveground use, intended principally for the storage of oil fuel in domestic type applications.

NOTE: Category 1 tanks should not be used for the storage of flammable liquids as they do not incorporate a liquid seal.

- (b) *Category 2*—Vertical or horizontal cylindrical tanks of up to 2500 L capacity, for aboveground use, intended principally for farms and similar open space locations.
- (c) *Category 3*—Rectangular tanks and tanks with unconventional shapes, intended principally for industrial use above-ground as either head tanks or storage tanks.
- (d) *Category 4*—Horizontal cylindrical tanks of up to 150 m³ capacity, for underground or above-ground use, intended principally for industrial or service station use.
- (e) *Category 5*—Vertical cylindrical tanks of up to 150 m³ capacity, for above-ground use, intended for industrial use.
- (f) *Category 6*—Vertical tanks of any capacity, of a size and type that is usually erected on site.

1.4.8 Class (of dangerous goods)

The number assigned to dangerous goods which exhibit a common single or most significant risk, determined from the criteria given in the UN *Manual of Tests and Criteria* and listed in the ADG Code.

1.4.9 Combustible liquid

Any liquid, other than a flammable liquid, that has a flash point, and has a fire point that is less than its boiling point.

For the purpose of this Standard, combustible liquids are divided into two classes as follows:

- (a) *Class C1*—A combustible liquid that has a closed cup flash point of greater than 60°C and no greater than 93°C.

- (b) *Class C2*—A combustible liquid that—
- (i) has a flash point of greater 93°C; or
 - (ii) has been excluded from being a flammable liquid by any of the criteria for sustaining combustion.

NOTES:

- 1 A water miscible solution with a water content of more than 90% by mass, which has been excluded from being a flammable liquid and which does not have a fire point less than its boiling point is not a combustible liquid.
- 2 The boiling point is that point at which it is no longer possible to achieve the rate of temperature rise required by ISO 2592 for the determination of fire point.
- 3 ISO 2592, IP 36 and ASTM D92 are technically equivalent test methods for the determination of fire point and fire point by Cleveland open cup tester.

1.4.10 Combustible materials

Materials deemed to be combustible when tested in accordance with AS 1530.1.

1.4.11 Commercial building

Any building that is partly or wholly used for offices, professional rooms, consulting rooms, or the like.

1.4.12 Compound

An area bounded by ground contours or by a bund, and intended to retain spillage or leakage. This includes the floor of the compound.

1.4.13 Confined space

A space of any volume as defined by AS/NZS 2865.

1.4.14 Container

Anything in which dangerous goods are wholly or partly encased, covered, enclosed, contained or packed, whether such a thing is empty or partially or completely full, but does not include a vehicle or freight container.

1.4.15 Dangerous goods

Substances and articles that—

- (a) are defined in the ADG Code; or
- (b) are determined to be dangerous goods by relevant legislation.

1.4.16 Decant

To pour from one container into another.

1.4.17 Desensitized explosives

Explosive substances which are dissolved or suspended in water or other liquid substances, to form a homogeneous liquid mixture to suppress their explosive properties.

NOTE: Entries in the dangerous goods list of the 18th revised edition of the UN *Recommendations on the Transport of Dangerous Goods—Model Regulations* are UN 1204, UN 2059, UN 3064, UN 3343, UN 3357 and UN 3379.

1.4.18 Dispenser

A fuel transfer unit, usually combined with a metering device, that is intended principally for the dispensing of liquids from a storage tank to the fuel tank of a vehicle, boat or aircraft.

1.4.19 Distillery

A place or establishment where the distilling of alcoholic spirits, for use in the production of potable spirits, is carried out.

1.4.20 Dwelling

A place of residence or abode.

1.4.21 Environmentally sensitive area

The term includes, but is not limited to—

- (a) a water catchment area;
- (b) a reservoir for drinking water;
- (c) a freshwater or marine environment; and
- (d) a national park or equivalent.

1.4.22 Explosive limit (flammable limit)

1.4.22.1 General

LFL and UFL, as defined below are derived from IEC 60050-426, and adopted in AS/NZS 60079.10.1.

1.4.22.2 Lower flammable limit (LFL)

The concentration of flammable gas, vapour or mist in air, below which an explosive atmosphere will not be formed.

1.4.22.3 Upper flammable limit (UFL)

The concentration of flammable gas, vapour or mist in air, above which an explosive atmosphere will not be formed.

1.4.23 Fire point

In relation to a liquid, the fire point is the temperature at which the liquid, when tested according to the method set out in ISO 2592, first evolves vapour at a sufficient rate to sustain burning for at least five seconds after application of the specified test flame.

NOTE: ISO 2592, IP 36 and ASTM D92 are technically equivalent test methods for the determination of flash and fire points by Cleveland open cup tester.

1.4.24 Fire resistance level (FRL)

The grading period, in minutes, determined in accordance with AS 1530.4 for—

- (a) structural adequacy;
- (b) integrity; and
- (c) insulation,

and expressed in that order (e.g. 60/60/30).

1.4.25 Fire-safe valve

A valve complying with the fire type test requirements of ISO 10497, API Spec 6FA, API Spec 6FD, API Std 607 or other recognized Standard, incorporating a handle of fire resistance not inferior to the body material and having no brass or bronze internal parts.

1.4.26 Firewall

A wall or other barrier having a specified fire resistance level, constructed and placed for the purpose of preventing the spread of fire.

1.4.27 Flame arrester

A device consisting of an arrester element, arrester housing and associated fittings, used to prevent the passage of a flame.

1.4.28 Flammable liquids

For the purpose of this Standard, flammable liquids are liquids, or mixtures of liquids, or liquids containing solids in solution or suspension (for example, paints, varnishes, lacquers, etc., but not including substances otherwise classified on account of their dangerous characteristics) which give off a flammable vapour at temperatures of not more than 60°C, closed cup test, normally referred to as the flash point.

Flammable liquids include—

- (a) liquids stored or handled at temperatures at or above their flash point; and
- (b) substances that are stored or handled at elevated temperatures in a liquid state and which give off a flammable vapour at a temperature at or below the maximum storage or handling temperature.

Flammable liquids do not include liquids meeting the above definition with a flash point of more than 35°C which do not sustain combustion if—

- (i) they have passed a suitable combustibility test (refer to Sustained Combustibility Test prescribed in the UN Manual of Tests and Criteria, Part III, sub-section 32.5.2); or
- (ii) their fire point according to ISO 2592:2000 is greater than 100°C; or
- (iii) they are water miscible solutions with a water content of more than 90% by mass.

NOTES:

- 1 The above definition is consistent with the definition of flammable liquids in ADG 7.4 except for the omission of open-cup testing for flash point. This has been omitted to conform to GHS classification which is based solely on closed cup testing. This omission is consistent with a provision in the UN Model regulations.

GHS does provide for exemption based on the UN Sustained Combustibility Test, but does not provide for—

- (a) inclusion of heated liquids (as GHS has no consideration of temperature); and
- (b) exclusions based on fire point or water miscibility.

- 2 Liquids excluded as not sustaining combustion are included within the definition of combustible liquids in this Standard.
- 3 Packing group provides further information on flammable liquid classification (see Clause 1.4.50).
- 4 Liquids with a flash point less than 60°C that are excluded by not sustaining combustion, may present a risk of fire and explosion if there is a hazardous area in the head space of a tank or package. An assessment of the risk needs to be undertaken based on AS/NZS 60079.10.1.

1.4.29 Flash point

The lowest temperature, corrected to a barometric pressure of 101.3 kPa, at which application of a test flame causes the vapour of the test portion to ignite under the specified conditions of test.

NOTE: Closed-cup flash point methods are given in the AS/NZS 2106 series.

1.4.30 Foam (firefighting foam)

A stable aggregation of small bubbles, of lower density than oil or water, the properties of which are such that the foam may be used as a flame-smothering blanket, to prevent the entry of air, and to suppress vapour.

NOTES:

- 1 Foams are defined by their expansion rate and are divided into three expansion ranges:
 - (a) Low-expansion foam—expansion up to 20.
 - (b) Medium-expansion foam—expansion from 20 to 200.
 - (c) High-expansion foam—expansion from 200 to approximately 1000.
- 2 Foam is made by mixing air into a solution of water and foam concentrate, by means of suitably designed equipment. Such foam flows freely over the surface of burning liquid and forms an air-excluding, continuous blanket that seals volatile vapours from contact with air. It resists disruption from wind, drafts, heat or flame and is capable of resealing in case of mechanical rupture. Firefighting foams retain these properties for relatively long periods of time.

1.4.31 Foam application methods

- (a) *Surface application* A method of applying firefighting foam to the surface of a liquid. One of three types of discharge device may be used; these are classified according to the way that they apply foam to the surface, as described below:
 - (i) A Type I discharge outlet is one that conducts and delivers the foam gently onto the liquid surface without submerging the foam or agitating the surface of the liquid.
 - (ii) A Type II discharge outlet is one that does not deliver the foam gently onto the liquid surface, but is designed to lessen the submergence of the foam and agitation of the liquid's surface.
 - (iii) A Type III discharge outlet is one that causes the foam to fall directly onto the surface of a burning liquid, causing general agitation.
- (b) *Sub-surface injection method* A method of conducting and applying foam in which the foam is discharged into the tank from below the liquid surface.

1.4.32 Foam concentrate

A concentrated liquid foaming agent, as received from the manufacturer.

1.4.33 Foam solution

A homogeneous mixture of water and foam concentrate in the proportions specified by the manufacturer.

1.4.34 GHS

The Globally Harmonized System of Classification and Labelling of Chemicals published by the United Nations.

1.4.35 Hazardous area

An area (three-dimensional space) in which an explosive atmosphere, due to flammable gas or flammable vapour, is or may be expected to be present, in quantities such as to require special precautions for the construction, installation and use of equipment.

NOTE: The classification of hazardous areas in relation to flammable liquids is given in AS/NZS 60079.10.1.

1.4.36 Hot work

The use or operation of any equipment that is likely to produce a source of ignition or a direct source of ignition including the following:

- (a) Welding or flame cutting equipment.
- (b) Grinders, electric drills, lights, connectors and other electrical equipment not deemed suitable for the hazardous area.
- (c) Hot tapping equipment.

- (d) Spark ignition engines or compression engines not specifically designed or deemed to be suitable for hazardous areas.
- (e) Matches, naked lights, cigarettes, cigarette lighters, flame or sparks.
- (f) Hand tools that through normal use could create a spark.
- (g) Any other thing that is likely to produce a source of ignition or be an ignition source.

1.4.37 Ignition source

A source of energy sufficient to ignite a flammable atmosphere. Examples of ignition sources include naked flames, exposed incandescent material, electrical welding arcs, mechanical sparks, electrical discharge due to static electricity, and electrical, electronic or mechanical equipment not suitable for use in hazardous areas.

1.4.38 Incompatible

- (a) In relation to dangerous goods or other goods, goods that are—
 - (i) likely to interact with the dangerous goods so as to increase the hazard when mixed or otherwise brought into contact with the liquids; or
 - (ii) listed in the ADG Code as being incompatible; or
 - (iii) declared by the regulatory authority to be incompatible.
- (b) In relation to packaging or transfer equipment, a container or item of equipment that is constructed of a material likely to interact with the liquids such that it is weakened or damaged to the extent that risk increases.

1.4.39 Installation

All the facilities on a site used for storing or handling flammable or combustible liquids.

1.4.40 Intermediate bulk container (IBC)

Rigid or flexible portable container for the transport of dangerous goods with a capacity of up to 3 m³ as defined in the ADG Code and complies with UN Recommendations on the Transport of Dangerous Goods—Model Regulations.

NOTES:

- 1 Requirements for the construction and testing of IBCs are included in the ADG Code.
- 2 For IBCs suitable for flammable liquids complying with the ADG Code that are connected to any piping or product delivery system, there are additional risk controls. See Clause 5.10.

1.4.41 Liquids

Where the word ‘liquids’ is used without further qualification, it includes both flammable and combustible liquids.

1.4.42 Manufactured product

Dangerous goods of Class 3 Packing Group II or III—

- (a) that are a suspension or solution of at least 10% non-volatile materials as determined by AS 1580.301.1;
- (b) of which less than 3% of the mobile solvent layer separates in the solvent separation test specified in the UN *Manual of Tests and Criteria*; and
- (c) the viscosity of which meets the criteria specified in the ADG Code.

NOTES:

- 1 The term includes most solvent-based paints, lacquers and polishes.
- 2 Reference should be made to the ADG Code.

1.4.43 Material safety data sheet (MSDS)/Safety data sheets (SDS)

NOTE: See Clause 1.4.63.

1.4.44 May

Indicates the existence of an option.

1.4.45 Minor storage

The storage of flammable and combustible liquids, in various locations, in quantities conforming to the criteria specified in Section 2.

1.4.46 Non-combustible

Material that does not support combustion or is deemed to be non-combustible when tested in accordance with AS 1530.1.

1.4.47 On-site protected place

A building where people are employed within the property boundary, including offices, warehouses, manufacturing or processing areas, amenities and other dangerous goods stores where quantities exceed minor storage.

1.4.48 Package

The complete product of the packing operation, consisting of the packaging and its contents prepared for transport.

1.4.49 Packaging

A receptacle and any other components or materials necessary for the receptacle to perform its containment function, and in relation to dangerous goods, a container having a capacity not exceeding 500 L and having a net mass of not more than 500 kg.

1.4.50 Packing Group (PG)

One of three hazard groups to which dangerous goods (of Classes other than 1, 2, 6.2 and 7) are assigned in the ADG Code, in decreasing order of hazard, by the Roman numerals 'I' (high danger), 'II' (medium danger) and 'III' (low danger).

The following flammable liquids are assigned to Packing Group III:

- (a) Liquids stored or handled at temperatures at or above their flash point.
- (b) Substances that are stored or handled at elevated temperatures in a liquid state and which give off a flammable vapour at a temperature at or below the maximum storage or handling temperature.

Other flammable liquids are assigned to packing groups in accordance with ADG criteria which correspond to GHS categories as shown in Table 1.1.

TABLE 1.1
PACKING GROUP, GHS CATEGORY AND ADG CRITERIA

Packing Group	GHS Category	Criteria
I	1	Flash point <23°C and initial boiling point ≤35°C
II	2	Flash point <23°C and initial boiling point >35°C
III	3	Flash point ≥23°C and ≤60°C
(See Note)	4	Flash point >60°C and ≤93°C

NOTE: For GHS Category 4, see under combustible liquids.

1.4.51 Pipework

An assembly of pipes, hoses, valves, fittings and associated appliances.

1.4.52 Polymerizable material

Any liquid, solid, or gaseous material which may polymerize (combine or react with itself) so as to expand or cause dangerous evolution of gas or heat.

1.4.53 Port area

The land and sea area established by legislation.

NOTE: Some port areas may overlap and legal requirements should take account of this possibility.

1.4.54 Potable spirits

Liquids that are intended for human consumption, or are ingredients used in the production of such liquids, and which have a degree of strength not less than 24% alcohol (ethanol) by volume (v/v).

1.4.55 Premises

The area under the control of the occupier.

1.4.56 Protected place

Any of the following:

- (a) A dwelling, residential building, place of worship, public building, school or college, hospital, theatre, and any building or open area in which persons are accustomed to assemble whether it is within or outside the property boundary of the installation.
- (b) A factory, workshop, office, store, warehouse, shop, or building where persons are employed, that is outside the property boundary of the installation.
- (c) A ship lying at permanent berthing facilities.
- (d) Any storage facility for dangerous goods outside the property boundary of the installation, except for those defined as minor storages in this or other Standards or regulations.

1.4.57 Public place

Any place other than private property, open to the public, which the public has a right to use and which includes a public road. Parking areas for commercial buildings are not considered to be public places.

1.4.58 Rail tank vehicle (rail tanker)

A rail wagon, of which a tank forms an integral part.

1.4.59 React dangerously

The reaction of substances in a manner that directly creates a hazard due to the reaction—

- (a) being violent;
- (b) producing an explosion;
- (c) producing a potentially explosive combination of products;
- (d) producing fire or rapid evolution of heat; or
- (e) producing toxic vapour or toxic gas.

NOTE: Examples of substances that react dangerously are—

- (a) calcium hypochlorite ('pool chlorine') and oil or petrol; and
- (b) hydrogen peroxide and organic substances.

1.4.60 Regulatory authority

The authority responsible for the administration of control of the storage, transport and use of dangerous goods.

NOTE: More than one authority may be involved in relation to such matters.

1.4.61 Restricted area

An area to which access is available only to persons authorized by the occupier.

1.4.62 Road tank vehicle (road tanker)

A road vehicle, of which a tank forms part, or to which a tank (other than a portable tank) is attached.

1.4.63 Safety data sheets (SDS)/Material safety data sheet (MSDS)

A document which provides information on the identification, hazards, precautions for use and safe handling of a specific chemical product, and which complies with relevant legislation.

NOTE: Refer also to Safe Work Australia, *Model Code of Practice: Preparation of Safety Data Sheets for Hazardous Chemicals*.

1.4.64 Segregated

Isolated from each other within the store.

1.4.65 Separated

Isolated from the storage by a given minimum distance.

1.4.66 Shall

Indicates that a statement is mandatory.

1.4.67 Should

Indicates a recommendation.

1.4.68 Subsidiary risk (subrisk)

A reference to any additional hazard that the dangerous goods might have, indicated by the subsidiary risk number to which the dangerous goods are assigned. Dangerous goods are assigned a subsidiary risk if they—

- (a) satisfy the criteria specified in the UN *Manual of Tests and Criteria* for their assignment to a subsidiary risk;
- (b) are assigned a subsidiary risk in the ADG Code; or
- (c) are assigned a subsidiary risk by the regulatory authority.

1.4.69 Tank

A container other than a package, intended for the storage or transport of a liquid and having a capacity greater than 500 L. Where a tank category is mentioned, it means the category specified in AS 1692 and defined in Clause 1.4.7.

A tank may be one of the following types:

- (a) *Static storage tank* A tank of a type described in AS 1692, intended to remain permanently in place once installed.
- (b) *Demountable delivery tank* A tank intended to be placed on a vehicle from time to time to enable use as a temporary delivery tanker.
- (c) *Tank container* A tank fitted with frames to international freight container dimensions in accordance with AS 3711.6. (This type of tank is also referred to as an 'ISO Tank'.)

- (d) *Underground tank* A static storage tank wholly or partially buried below the surrounding ground gradient.
- (e) *Above-ground tank* A static storage tank which is not an underground tank.
- (f) *Portable tank* A multimodal portable tank, including a shell fitted with service equipment and structural equipment necessary for the transport of dangerous substances.

A portable tank meeting this definition is capable of being loaded and discharged without the need of removal of its structural equipment. It possesses stabilizing members external to the shell, and is capable of being lifted when full. It is designed primarily to be loaded in a transport vehicle or ship and is equipped with skids, mountings or accessories to facilitate mechanical handling.

NOTE: For IBCs when used as static storage tanks, see Clause 5.10.

1.4.70 Tank vehicle (tanker)

A road tank vehicle or a rail tank vehicle.

1.4.71 Tinting

The opening, reclosing and shaking of a can to permit addition of a concentrated colourant to a base paint in order to produce the required colour.

1.4.72 Transit storage

The storage of flammable or combustible liquids for at least 12 h and less than five days, where such liquids are intended for further transport to another location.

1.4.73 Vapour barrier

A wall or other barrier constructed and placed with the object of preventing the passage of vapour from any one place to another.

1.4.74 Winery

An establishment for making wine.

1.4.75 Work permit

A written document which stipulates the conditions under which work within a specified area may be carried out.

SECTION 2 MINOR STORAGE

2.1 SCOPE OF SECTION

This Section specifies the criteria for ‘minor storage’ of flammable and combustible liquids, and the requirements for such storage.

Storage of flammable or combustible liquids in quantities not exceeding those listed in Table 2.1 and complying with the requirements of this Section, may be classified as minor storage and are exempted from the other sections of this Standard except as required by this Section.

The storage of minor quantities of liquids under conditions that do not comply with the requirements of this Section, or of quantities of liquids greater than those given in Table 2.1, shall comply with the requirements of other relevant Sections of this Standard.

Minor storage may exist as a part of a premises or complex in which no other flammable or combustible liquids exist, or may be part of a premises whose function is to use flammable or combustible liquids in processes or storage.

NOTES:

- 1 Workplace safety regulations and guidelines may apply even to quantities defined as minor storage.
- 2 For liquids with subsidiary risks, or in areas where decanting, package filling or processing occur, additional safety precautions (e.g. ventilation), may be required. Guidance may be found in relevant exposure standards, MSDS/SDS and product labels.

2.2 MINOR STORAGE QUANTITIES

2.2.1 Quantities allowable as minor storage

The quantities of flammable and combustible liquids allowable as minor storage are given in Table 2.1.

2.2.2 Quantities of Packing Group I

Flammable liquids of PG I, in containers larger than 2.5 L, shall not be kept in minor storage unless they are essential for daily operations and handled only by trained personnel.

2.2.3 Multiple minor storages

Where there is more than one minor storage on the same premises, such storages shall be separated by a distance of at least—

- (a) 20 m, if they are indoors; or
- (b) 15 m, if they are outdoors.

This distance shall be measured from the outermost package or tank in the minor storage (see Figure 2.1).

If two or more buildings are separated by at least 5 m of open space (i.e. an area without a roof and accessible for firefighting at all times), or by a concrete or double-brick wall capable of preventing the spread of a fire, a separate indoor minor storage quantity may be applied to each building.

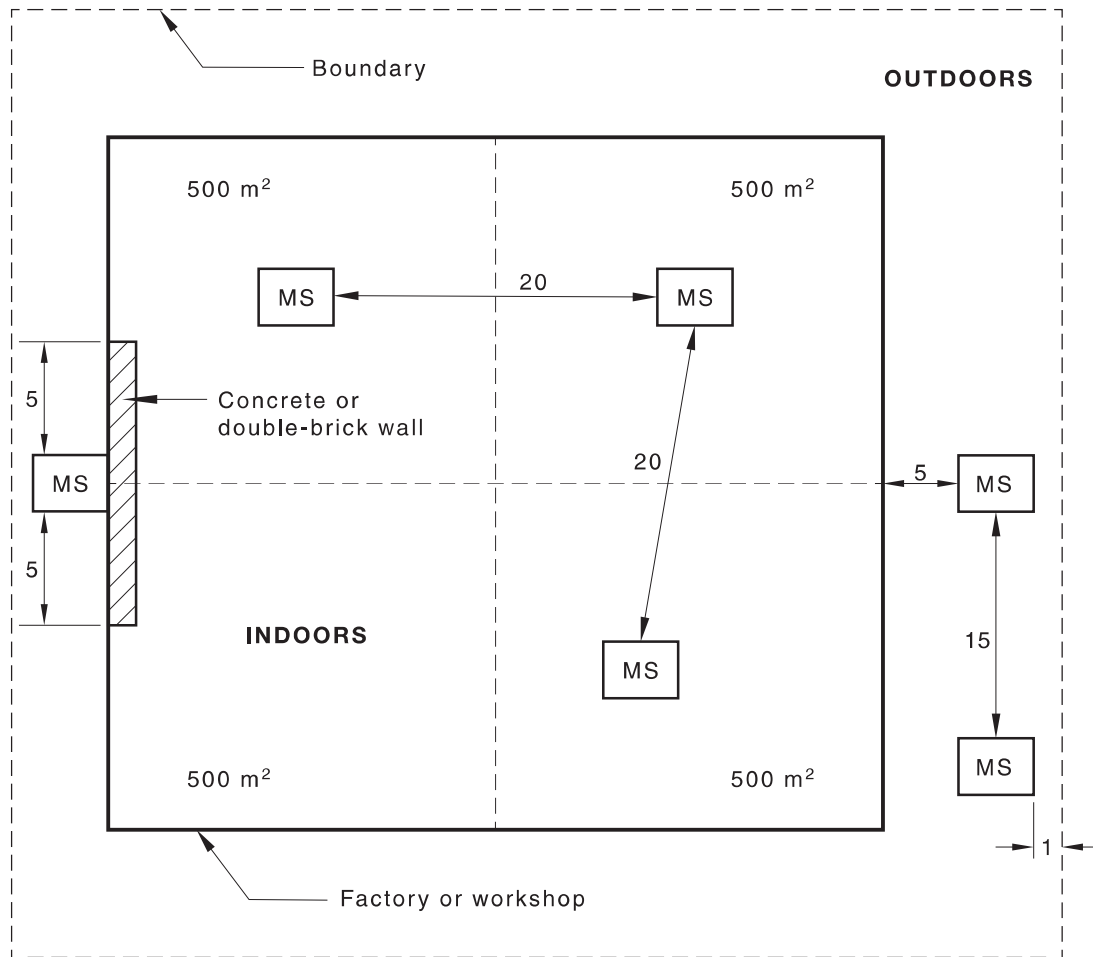

LEGEND:
MS = Designated minor storage area

DIMENSIONS IN METRES

FIGURE 2.1 EXAMPLES OF LOCATIONS OF MINOR STORAGE

2.2.4 Separation between minor storage and other stores

A minor storage shall be separated from any other store of flammable and/or combustible liquids that is larger than minor storage by—

- the distance to an on-site protected place [as given in Clause 4.3.1(b)]; or
- at least 5 m,

whichever is the greater.

This Clause (2.2.4) does not apply to storage cabinets having a maximum capacity of 250 L.

2.2.5 Minor storage on open land

2.2.5.1 General

The following requirements and conditions shall apply to minor storage on open land having an area greater than 2 ha:

- The storage shall be on land that is used, or intended to be used, for agricultural, horticultural, floricultural or pastoral purposes, including golf courses and national parks.
- Liquids shall not be for sale or commercial distribution.

- (c) Liquids shall be kept at least 1 m away from any boundary, workshop, dwelling or protected place, body of water, watercourse or environmentally sensitive area.
- (d) The ground around the store shall be kept clear of combustible vegetation or refuse for a distance of at least 3 m.
- (e) Any potential flow of spillage shall be prevented from reaching a protected place, watercourse or property boundary by such means as the use of natural ground slope, or the provision of a diversion channel, kerb or bund.

NOTE: Additional assessment, and consultation with the authority having jurisdiction, should be undertaken if the minor storage is proposed to be located on open land within a designated bushfire prone area.

2.2.5.2 *Polyethylene or composite storage tanks for minor storage*

This Clause specifies requirements for the storage of combustible liquids within above-ground polyethylene storage tanks that are rotationally moulded in one piece seamless construction in accordance with AS/NZS 4766, or composite storage tanks, as follows:

- (a) The maximum capacity of such tanks shall not exceed 10 000 L.
- (b) Such tanks shall have provision to dissipate static electricity and prevent splash filling.
- (c) Such tanks shall have sufficient means for venting to prevent damage to the tank as a result of normal operational use of the tank.
- (d) Such tanks are to be located within a bund compliant with Clause 5.8.
- (e) Such tanks shall be separated from security fences and both onsite and offsite protected places by a distance of no less than 15 m.
- (f) Such tanks shall not be located within the confines of a building unless they comply with Clause 5.6.3 for C1 Products.
- (g) If the liquid level is measured by a dipstick, a suitable plate to prevent puncture to the bottom of the tank shall be required.

Polyethylene or composite tanks shall only be used with secondary containment that is non-combustible.

2.2.6 **Minor storage on construction sites**

The requirements and conditions set out in Clause 2.2.5.1, with the exception of Item (a), shall apply to minor storage on construction sites. Polyethylene or composite tanks shall not be used on construction sites.

TABLE 2.1
MINOR STORAGE

Location	Flammable liquids		Combustible liquids C1, C2	Manufactured products
	PG I or PG II	PG III		
<i>Residential buildings of any type</i>				
Within a residence	5 L	25 L	50 L total C1 and C2	50 L
In a garage attached to a residence with a 60/60/60 FRL separating wall	25 L	50 L	100 L total C1 and C2	250 L
Outdoors, or in a shed or garage, separated from the residence or any other building by 1 m space	100 L	250 L	500 L total C1 and C2	250 L
Outdoors, uncovered, or in a shed or garage, separated from the residence or any structure or boundary by either 3 m of space or a wall having an FRL of 180/180/180	250 L	250 L	500 L total C1 and C2	250 L
A supply tank for domestic oil-fired appliances (see AS 1691) is excluded from any calculation of the quantity stored on the premises				
<i>Educational establishments (excluding laboratories)</i>				
For storage outdoors, or in sheds or attachments, the limits for the corresponding entry in residential buildings shall apply	5 L per 50 m ² of floor space	10 L per 50 m ² of floor space	500 L total C1 and C2 per 50 m ² of floor space	
<i>Laboratories</i> (see Notes 1, 2 and 5)	50 L per 50 m ² of floor space, or 50 L in a room of up to 50 m ² of floor space	100 L per 50 m ² of floor space	200 L total C1 and C2	The limit for any manufactured product is the same as for a liquid of the same Packing Group
<i>Commercial buildings</i>				
Indoors	10 L per 50 m ² of floor space, but 5 L for any tenancy of less than 50 m ² area	25 L per 50 m ² of floor space, but 25 L for any tenancy less than 50 m ² area	500 L total C1 and C2 per 50 m ² of floor space but 500 L for any tenancy less than 50 m ² area	

(continued)

TABLE 2.1 (continued)

Location	Flammable liquids		Combustible liquids C1, C2	Manufactured products
	PG I or PG II	PG III		
<i>Hospitals</i> Indoors	10 L per 50 m ² of floor space	25 L per 50 m ² of floor space	500 L total C1 and C2 per 50 m ² of floor space	The limit for any manufactured product is the same as for a liquid of the same Packing Group
<i>Factories, workshops</i> Indoors	1 L per 2 m ² of floor space with no more than 250 L in any 500 m ² area	1 L per 1 m ² of floor space with no more than 500 L in any 500 m ² area	4 L per 1 m ² of floor space with no more than 2000 L in any 500 m ² area	In packages only— 2000 L
<i>At commercial buildings, factories, workshops, hospitals and warehouses</i> Outside the building—				
(a) in attached outhouses or sheds if separated by a partition having an FRL of 60/60/60; or	250 L	As immediately above	2500 L	
(b) outside, or in a detached shed or outhouse separated from the factory or workshop by at least 1 m	As immediately above	1400 L in tanks not over 700 L each, or in packages	5000 L	
<i>Shops</i>	As for factories and workshops (above) but no container for PG I or PG II liquid may exceed 20 L capacity			Flammable products: 10 000 L, of which no more than 2000 L are PG II, provided that storage is closed packages, not to be opened except for tinting paint for immediate sale
<i>Warehouses</i>	As for factories and workshops (above)			
<i>Service stations</i> Indoors	500 L total in packages Any packages kept in a sales area shall be unopened packages not over 20 L capacity	1250 L total in tanks or packages	3000 L total C1 and C2	As for factories, workshops

(continued)

TABLE 2.1 (continued)

Location	Flammable liquids		Combustible liquids C1, C2	Manufactured products
	PG I or PG II	PG III		
<i>Service stations</i>		An additional 1000 L in packages can be kept outdoors		As for factories, workshops
<i>Outdoors</i>				
<i>Open land</i>				
Outdoors above ground	5000 L	5000 L	10 000 L	
Underground tank(s)	5000 L	5000 L	10 000 L	As for shops
<i>Construction sites</i>	2500 L	5000 L	10 000 L	As for shops

NOTES:

- 1 In the case of laboratories, commercial buildings and the like, this Table is intended to cater for the day-to-day working stock in the laboratory or workroom. If these quantities are to be exceeded, it will be necessary to install a cabinet or major store facility according to the scale needed.
- 2 Laboratories that are constructed, operated and equipped in the form of a flammable liquid storage room, and are used for the analysis of flammable liquids being processed, are exempt from this Table.
- 3 It is permissible to store at the same time in the same area, the maximum permissible allowance for each or all of the other packing groups of flammable liquids or classes of combustible liquids.
- 4 Where the maximum allowance is specified in terms of quantity per unit area, any arrangement which results in concentration at one point should be avoided. Such aggregation contravenes the intent of minor storage, which is dispersal, and proper storage provisions as in Section 4 could be necessary.
- 5 Materials being analysed, used, mixed, blended or reacted upon on laboratory benches or in fume cupboards are exempt from the limitations of this Table.

2.3 PRECAUTIONS APPLYING TO MINOR STORAGE

2.3.1 Location of minor storage

The following requirements and recommendations apply to the location of an indoor minor storage:

- (a) If the storage is located on a floor that is above the building's lowest floor (i.e. on a floor that is above the ground floor or basement), its location shall not jeopardize the safety of any areas on lower levels of the building or impede firefighting operations.
- (b) Flammable vapours and spilt liquids shall be prevented from escaping to any lower levels of the building.
- (c) Concentrated storage of liquids in any one area shall be avoided, so as to reduce the fire load and the potential rate of fire spread.
- (d) The storage area shall be adequately ventilated.
- (e) The build-up of flammable vapours should be avoided (see Clause 2.3.3).

2.3.2 Operations

The following handling requirements and precautions apply:

- (a) Persons who handle the liquids shall be fully aware of the hazards involved.
- (b) All storage areas shall be secured against access by unauthorized persons at all times.
- (c) Packages shall not be placed where they could hinder escape from a building in an emergency.
- (d) Care should be taken when decanting or transferring flammable liquids. Dispensing pumps or self-closing metal taps should be used, in order to reduce the hazards of splash filling, spillage and vapour escape.
- (e) Packages shall be kept closed when not in use. Packages containing flammable liquids should only be opened or decanted in well-ventilated areas and away from any potential ignition source.
- (f) The area in or around the minor storage shall be kept free of combustible materials and residues.
- (g) Any materials that might react dangerously if mixed shall be kept apart so that the possibility of reaction is minimized, e.g. fuel and pool chlorine.
- (h) Liquids should not be stored near any hot surfaces (e.g. steam pipes, furnace walls or engines) or where they might be accidentally exposed to heat (e.g. from escaping steam).
- (i) Liquids should be transferred and moved in a manner that reduces the likelihood of spillage, vapour escape or fire.

NOTE: Section 9 deals with operational safety matters that may be pertinent to minor storage but which may be regarded as advisory.

2.3.3 Control of ignition sources (flammable liquids only)

Except for domestic premises, AS/NZS 60079.10.1 shall be consulted for hazardous area classification if the volume of flammable liquids exceeds—

- (a) 100 L in closed containers;
- (b) 25 L for decanting purposes, e.g. petrol transfer to a motor vehicle or lawn mower;
- (c) 5 L in open containers for occasional use; or
- (d) 1 L in open containers for continuous use.

There shall be no uncontrolled sources of ignition in any space in which a flammable mixture of vapour and air could be present.

WARNING: EVEN SMALL QUANTITIES OF FLAMMABLE LIQUID, IF SPILT, CAN CREATE A VAPOUR CLOUD THAT CAN TRAVEL CONSIDERABLE DISTANCES AND FLASHBACK.

2.3.4 Spillage control

All spills and leaks shall be cleaned up immediately. Any waste shall be disposed of safely and in accordance with the local regulations.

Liquids shall not be allowed to reach ignition sources, stores of other chemicals, or combustible materials (e.g. timber and paper), or flow into drains or onto neighbouring land, or enter any creek, pond or waterway.

NOTES:

- 1 Precautions should be based at least on the loss of contents of the largest container kept.
- 2 A spill-response kit may consist of—
 - (a) a readily identifiable, suitable container with a lid or cover containing absorbent materials;
 - (b) suitable personal protective equipment; and
 - (c) suitable equipment required for spill clean-up.
- 3 Oils of animal or vegetable origin can oxidize, with the generation of heat and the possibility of spontaneous ignition if they are absorbed onto combustible absorbents.

2.3.5 Fire protection and warning signs

At premises other than residences or farms, in locations where more than 100 L of flammable liquids, or more than 1000 L of combustible liquids are stored, or where flammable liquids are decanted, the following requirements apply:

- (a) At least one portable fire extinguisher, having a suitable rating for use with the range of materials being kept, shall be readily accessible and adjacent to the minor storage area. Where liquids are stored on open land, a fire extinguisher shall be provided if the liquids are decanted or transferred within 5 m of the storage.
- (b) In areas where flammable liquids are decanted, a sign bearing the following words shall be displayed:

DANGER—FLAMMABLE LIQUIDS—NO SMOKING—KEEP FIRE AWAY

Signs shall comply with AS 1319.

For retail areas with customer access, this requirement shall apply if the liquids are decanted or transferred, or are in packages having capacities of more than 25 L.

2.4 MINOR STORAGE IN TANKS

2.4.1 Construction

Any tank that is intended for the storage of flammable or combustible liquids shall comply with AS 1692 or other appropriate specification. A Category 1 tank shall not be used for flammable liquid. Polyethylene or composite tanks may be used for minor storage on open land in accordance with Clause 2.2.5.2.

2.4.2 Installation

For underground tanks, the installation requirements of Clause 5.12 shall apply.

2.4.3 Maintenance

Tanks shall be inspected and maintained regularly.

NOTE: Further guidance is given in Section 9.

SECTION 3 GENERAL REQUIREMENTS

3.1 SCOPE OF SECTION

This Section provides general requirements and recommendations that apply to stores of flammable or combustible liquids, in quantities greater than those classified as minor storage in Section 2.

Additional requirements that are specific to particular types of installation are given in other sections of this Standard.

NOTE: Recommendations for blending plants are given in Appendix B.

3.2 GENERAL DESIGN AND CONSTRUCTION REQUIREMENTS

3.2.1 Design safety and suitability

Any installation intended for the storage and handling of flammable or combustible liquids shall be designed and constructed so that it is safe and suitable for the conditions of use. Factors that need to be considered include the following:

- (a) Working pressures and structural stresses.
- (b) Heat, corrosion, or attack by the liquid being handled.
- (c) Site conditions such as topography, usage of adjoining areas, or the risk of natural disasters, e.g. flood, earthquake, lightning strikes.
- (d) Design of plant, equipment, and operating methods, so as to minimize fire and accident risks and the possibility of errors or misunderstanding by staff.
- (e) Specific design for emergencies (see Clause 3.2.2 and Section 10), particularly firefighting facilities.
- (f) The identification of the function of every valve, switch or control actuator, including any remote switches or actuators.
- (g) Safe access to and egress from all working locations.
- (h) Avoidance of ignition sources.
- (i) Ventilation for vapour dispersal, taking into account the possible effect of nearby structures, excavations, embankments, and the like.
- (j) Separation of potential hazards, including areas where activities cannot be controlled.
- (k) Points of vapour relief.
- (l) Spill control measures to avoid contamination of soil and water.

3.2.2 Emergency provisions

An installation shall be designed to facilitate the management of an emergency, taking into account—

- (a) the nature and quantity of the liquids stored;
- (b) the layout of the storage area;
- (c) access through or around walls or other barriers;
- (d) the type of construction of any buildings; and
- (e) the type and means of operation of any fire protection system.

NOTE: See also Sections 9, 10 and 11.

3.2.3 Minimization of vapour hazards

Where a flammable liquid is being used or transferred in such a manner that vapour is released, the ventilation, extraction, or dispersal provisions shall be sufficient to maintain exposure levels below the exposure standards published by Safe Work Australia.

3.2.4 Ignition sources

A hazardous area shall not extend beyond a boundary if it could encompass a fixed source of ignition on the adjacent property.

NOTE: Hazardous areas are defined in AS/NZS 60079.10.1.

3.2.5 Separation distances

3.2.5.1 General

Storages shall be separated from boundaries, ignition sources, protected places and accumulations of combustible materials by the minimum distances relevant to each type of storage as specified in Clauses 4.3 and 5.7, with the additional requirements and qualifications as set out in this Clause (3.2.5).

Where alterations to the installation or adjoining site result in a breach of the required separation distances, the installation shall be assessed and brought into compliance or decommissioned.

3.2.5.2 Separation to property boundary

The separation distance to any property boundary shall be at least that distance required by Table 4.2 or Table 5.3.

3.2.5.3 Separation to protected places on adjoining properties

The separation distance to a protected place on another property shall be at least as specified in Table 4.1 or Table 5.4, as appropriate. This distance may be measured across a boundary, provided that, if alterations on the adjacent property result in a breach of the separation distance, the installation will be modified or relocated to restore compliance or taken out of service.

Where the future installation of a protected place on the adjoining property is possible, the installation may be located in accordance with boundary separation distances, provided that the provisions stated in the above paragraph are satisfied.

NOTES:

- 1 The use of the protected place distance measured to the boundary of the adjacent property is recommended to eliminate future problems, although its use is a commercial decision.
- 2 A formal agreement or covenant may be used.

3.2.5.4 Adjacent occupancies storing flammable and combustible liquids

Where two adjacent premises under separate occupancies are each used for the storage and handling of flammable and combustible liquids and share a common boundary, the separation distances between tanks, package stores and other buildings may be measured as though both premises were under a single occupancy, provided that an agreement similar to that described in Note 2 to Clause 3.2.5.3 is in place, but providing for the alteration, redevelopment or change of ownership of either site.

3.2.5.5 On-site storage of other dangerous goods

The on-site storage of other classes of dangerous goods may require differing separation distances, as specified in the relevant Australian Standards or by legislation, or both. Where no such distances are specified, the storage containing the other dangerous goods should be considered as an on-site protected place and the relevant distance specified in this Standard applied.

3.3 MECHANICAL EQUIPMENT AND INSTALLATIONS

Mechanical equipment that meets any recognized industry standard for handling flammable liquids is deemed to meet the intent of Clause 1.4.37 for control of ignition sources in hazardous areas.

Examples of such standards include API standards for pumps and EN or AS/NZS standards for industrial trucks in hazardous areas.

NOTE: While standards under the ISO/IEC 80079 series may be used to provide guidance on possible ignition sources for mechanical equipment in hazardous areas, it is not a requirement of this standard that equipment complies with or is certified to these standards.

3.4 ELECTRICAL INSTALLATIONS AND EQUIPMENT

The following requirements shall apply to both electrical equipment and installations in areas designated as hazardous areas under the AS/NZS 60079.10.1:

- (a) *Electrical installations* All electrical installations shall be installed in compliance with the provisions of AS/NZS 3000 and AS/NZS 60079.14 that relate to electrical equipment in hazardous areas. The equipment shall be of a type certified to comply with the relevant Australian Standard or that has been approved for use in such locations by the relevant authority.
- (b) *Portable and mobile electrical equipment* All electrical equipment to which AS/NZS 3000 does not apply shall be selected and used in accordance with AS/NZS 60079.14, except where Item (c) below applies.
- (c) *Electric forklift trucks* In hazardous areas classified as Zone 2, electric forklift trucks and similar vehicles (e.g. stackers) not suitable for use in the Zone shall not be used except where Appendix C is complied with in all respects.

NOTE: Requirements for electric forklift trucks for use in hazardous areas are specified in AS 1915.

3.5 INTERNAL COMBUSTION ENGINES

Internal combustion engines may be used in hazardous areas as designated in the AS/NZS 60079.10.1 under the following conditions:

- (a) An engine designed and certified to AS 2359.12 may be used in the areas for which it is certified. In such cases, a hot work permit is not required.
- (b) A spark ignition engine not complying with Item (a) may be operated in a hazardous area if a hot work permit (see Clauses 9.8.3 and 9.8.6) has first been issued.
- (c) A compression ignition engine may be operated in a Zone 2 hazardous area if—
 - (i) any incorporated or attached electrical equipment is suitable for use in a Zone 2 hazardous area;
 - (ii) the air intake is either extended to outside the hazardous area, or is provided with a strangler valve or equivalent in the manifold, in which case the engine is attended when in use;
 - (iii) mechanical sparks cannot be produced in the engine compartment of the appliance during its operation; and
 - (iv) the exhaust has a spark arrester complying with AS 1019 or is extended to outside the hazardous area.

Any compression ignition engine not complying with AS 2359 [see Item (a) above] shall not be operated in a Zone 0 or Zone 1 area unless a hot work permit has been issued.

Forklift trucks and similar vehicles that are not suitable for use in Zone 2, or which do not comply with Items (a) to (c) above, shall not be used unless both the store and the vehicle comply with Appendix C and a work permit has been issued.

3.6 LIGHTING

Lighting shall be provided in accordance with the following requirements:

- (a) During the hours of operation, lighting shall be sufficient to provide safe working conditions that include, but are not limited to, clear visibility of all markings on packages, signs, instruments and other necessary items.

NOTE: A minimum value of 50 lx is recommended.

- (b) Sufficient lighting shall be available on any of the installation's internal roads when personnel at the premises might use them.

- (c) Any lighting in a hazardous area shall be suitable to operate in that area.

3.7 RESTRICTED USAGE

A storage that has a capacity greater than that given for minor storage shall only contain flammable or combustible liquids or both, unless the other products being stored will not react dangerously or be incompatible with the liquids.

If the store contains dangerous goods having a primary risk of other than Class 3, any other appropriate Australian Standards shall be consulted and the more stringent requirement shall apply.

Aerosols of Divisions 2.1 and 2.2 may be stored in a store for Class 3 dangerous goods if projectile protection (e.g. cages) is provided.

NOTE: Activities within package stores are described in Clause 4.10.

3.8 FIREWALLS AND VAPOUR BARRIERS

3.8.1 Conditions of use

Separation distances may be measured in a horizontal plane around the end of any intervening vapour barrier, provided that the barrier complies with the following:

- (a) For separation from protected places and on-site protected places, such a vapour barrier is also a firewall.
- (b) Building walls may be treated as being firewalls or vapour barriers provided that they qualify as such.

A wall on an adjacent property shall not be used as a firewall unless an agreement similar to that described in Clause 3.2.5.4 is in place.

Firewalls and vapour barriers may be used to achieve the separation distances in Tables 4.1, 4.2, 5.3 and 5.4 to protected places, public places and security fences.

3.8.2 Construction of firewalls

A firewall shall comply with the following requirements:

- (a) The fire resistance level shall be at least 240/240/240.
- (b) The firewall shall be impervious to vapour apart from around fire doors or other protected openings.
- (c) Any freestanding firewall shall be self-supporting and shall have adequate foundations.

- (d) The height of the firewall shall be sufficient to shield a protected place from heat radiation and flame impingement in the event that a potential storage fire becomes a reality, and vice versa.

NOTE: Where an FRL is required, reference should be made to the National Construction Code (NCC) for building purposes.

3.8.3 Construction of vapour barriers

A vapour barrier shall comply with the following requirements:

- (a) The material shall be impervious to vapour and deemed to be non-combustible when tested in accordance with AS 1530.1.
- (b) The top of the vapour barrier shall be above the height of the hazardous area pertaining at that point as determined in AS/NZS 60079.10.1.

3.9 SECURITY, SIGNS AND NOTICES

3.9.1 Control of access

All installations shall be appropriately secured against unauthorized access and tampering.

3.9.2 Signs and notices

At the entrance to any storage area greater than minor storage, the following signs shall be displayed:

- (a) A DANGER—NO SMOKING, NO NAKED FLAMES sign.
- (b) For flammable liquids, a Class label and subsidiary risk label (if any).
- (c) For combustible liquids, a COMBUSTIBLE LIQUID sign.

The following signs shall be placed at the entrance(s) to the premises:

- (i) A WARNING—RESTRICTED AREA, AUTHORIZED PERSONNEL ONLY sign.
- (ii) A sign listing the emergency contact names, titles and phone numbers relevant to the installation.
- (iii) The name, address and phone number of the occupier.
- (iv) A layout diagram showing the location of fixed fire protection facilities (where installed), the drainage system and the 'Emergency Stop' switches.

Where two or more points of access are adjacent to each other so that a single set of signs and notices are clearly readable from each point of access, duplicate signs and notices are not required.

Signs shall comply with AS 1319. Class labels shall conform to AS 1216 and be a minimum of 250 mm square. Other signs shall have lettering at least 50 mm high.

NOTE: Composite signs or pictographs complying with the above requirements may be used.

3.10 TRANSIT STORAGE

3.10.1 General

This Clause (3.10) specifies requirements for the transit storage (as defined in Clause 1.4.72) of flammable and combustible liquids.

Sections 1, 9, 10 and 11 also apply to transit storage.

3.10.2 Delineation of transit storage areas

Areas used for transit storage of flammable and combustible liquids shall be deemed to be separate areas if apart from each other and from any other storage areas, buildings or amenities by at least 15 m.

3.10.3 Requirements for transit storage

The following requirements apply to transit storage:

- (a) The aggregate quantity of flammable and combustible liquids held in each transit storage area shall not exceed 200 t.
- (b) Except where in freight containers or on board trucks, the maximum aggregate quantity of goods in each pallet bank or store in a transit storage area shall not exceed 25 t. Such pallet banks or stores shall be at least 5 m apart, or separated by a firewall having an FRL of at least 120/120/120.
- (c) Dangerous goods shall be segregated in accordance with the ADG Code, as though they were to be loaded onto a vehicle.
- (d) Parked road vehicles loaded with flammable liquids shall be separated from each other by at least 3 m, and from any other dangerous goods stores by at least 5 m. Vehicles shall be parked so that they can be driven out of the site without recourse to reversing.
- (e) Freight containers or tank containers containing flammable or combustible liquids in a transit storage area shall—
 - (i) not be stacked more than two containers high and two containers deep;
 - (ii) where stacked two containers deep, be provided with access for inspection to both sides of each stack;
 - (iii) not be in the same vertical stack as any container of any other Class of dangerous goods; and
 - (iv) be separated from containers of incompatible goods by at least 3 m.
- (f) Access and escape routes shall be clearly identified and kept clear at all times.
- (g) A spillage catchment and clean-up facilities shall be provided for the site. They shall be capable of handling the greater of—
 - (i) 100% of the capacity of the largest tank, freight container, IBC or tanker compartment; or
 - (ii) 10% of the aggregate quantity of packages in the area.

NOTE: In order to facilitate the management of emergencies, it is recommended that compound capacities be about 10% greater than the minimum values specified above.
- (h) The base of the transit storage area shall be sufficiently impervious to retain any spillage and to enable the recovery of any such spillage.
- (i) Appropriate facilities and materials shall be provided for the collection, containment and treatment of containers that are—
 - (i) leaking;
 - (ii) damaged and likely to leak as a result of such damage; or
 - (iii) awaiting disposal.

NOTES:

 - 1 A designated area may be provided for such containers.
 - 2 Packages of liquids that are leaking, or are impaired and might spill or leak, should not be loaded onto a vehicle unless in a waste recovery container.
- (j) Except in emergencies, liquids shall not be transferred between containers or decanted in a transit storage area.
- (k) Where relevant, and in emergencies, appropriate protective equipment shall be provided and used.

- (l) All dangerous goods and freight containers shall be marked in accordance with the ADG Code.
- (m) Transit storage areas shall be kept clear of any extraneous matter.
- (n) No fixed ignition sources shall be located within any hazardous area in the transit storage area.

3.10.4 Separation distances

Areas for transit storage shall be separated from protected places, on-site protected places and public streets by the minimum distances given in Table 4.1 for the aggregate volume of liquids stored. Areas shall be separated from boundaries by the minimum distances given in Table 4.2.

Transit storage areas shall be separated from any accumulation of combustible material, e.g. stacks of timber or plastic pallets, by at least 5 m.

All of the above separation distances shall be measured from the edge of the transit storage area.

3.11 IGNITION SOURCES

A vehicle shall not be regarded as an ignition source while it is entering or leaving a hazardous area surrounding a fuel dispenser or a bulk cargo transfer connection for the purposes of refuelling or for loading or unloading bulk liquids. However, it shall be treated as a potential ignition source during the period of the bulk liquid transfer, and the procedures and precautions given in Section 7 shall apply.

A vehicle shall not be regarded as an ignition source while it is entering or leaving the hazardous area outside a package storage area for the purposes of loading or unloading packages, provided that the hazardous area is not enclosed and the vehicle is not within the package storage area. During the loading and unloading, the vehicle's engine shall be switched off and shall not be started. Any vehicle shall not enter the package storage area unless—

- (a) it is suitable for the applicable hazardous area as given in AS/NZS 60079.10.1; or
- (b) the store and vehicle comply with Appendix C and a work permit has been issued (see also Clause 3.5).

SECTION 4 PACKAGE STORAGE AND HANDLING AREAS

4.1 SCOPE OF SECTION

This Section provides requirements and recommendations for the location, design and construction of package stores for flammable and combustible liquids and for areas where such packages are filled, decanted or cleaned. It applies to quantities greater than those allowed as minor storage.

Sections 3, 9, 10 and 11 also contain requirements that apply to package stores.

NOTE: Appendix D provides further recommendations for the storage of flammable liquids in coolrooms.

4.2 TYPES OF STORES

A package store for flammable or combustible liquids may be one or more of the following:

- (a) A detached store, being a store with or without a roof, or walls other than a bund [see Figure 4.1(a)(i), (ii), (iii), (iv)].
- (b) An attached fire-separated store, being a store attached to a building with outside entry and no communication to the associated building.
- (c) An attached store, sharing a wall or walls with the associated building and with a communicating fire door between the store and the associated building [see Figure 4.1(b)(i), (ii)].
- (d) An internal store, being a store wholly within a building, not sharing a common wall with the building and communicating with the associated building [see Figure 4.1(c)(i), (ii)].
- (e) Fire-separated stores, being grouped stores with no communication between adjacent storages [see Figure 4.1(d)].
- (f) A storage cabinet located within a building or located outside a building as an outdoor storage.
- (g) Facilities for the holding of materials awaiting use in a process, machine or the like.
- (h) A detached store, being a freight container complying with the requirements of Clause 4.8.

Variations of types (a), (b), (c) or (d), as shown in Figure 4.1, include—

- (i) stores with facilities for filling, decanting and cleaning of packages; or
- (ii) stores either at ground level or on a platform [see Figure 4.1(e)]; or
- (iii) a combination of both.

Further examples of package stores, including those not permitted by this Standard, are given in Figure 4.2.

A2

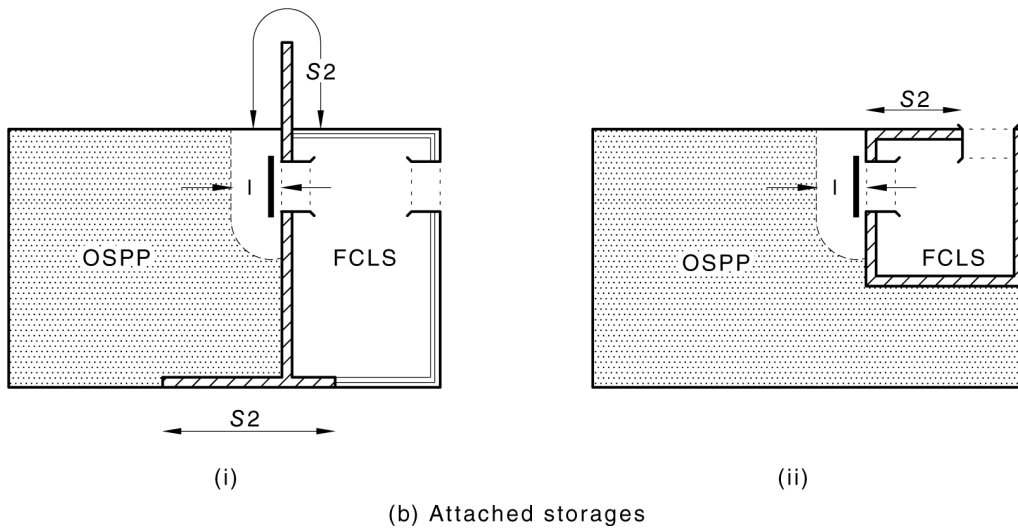
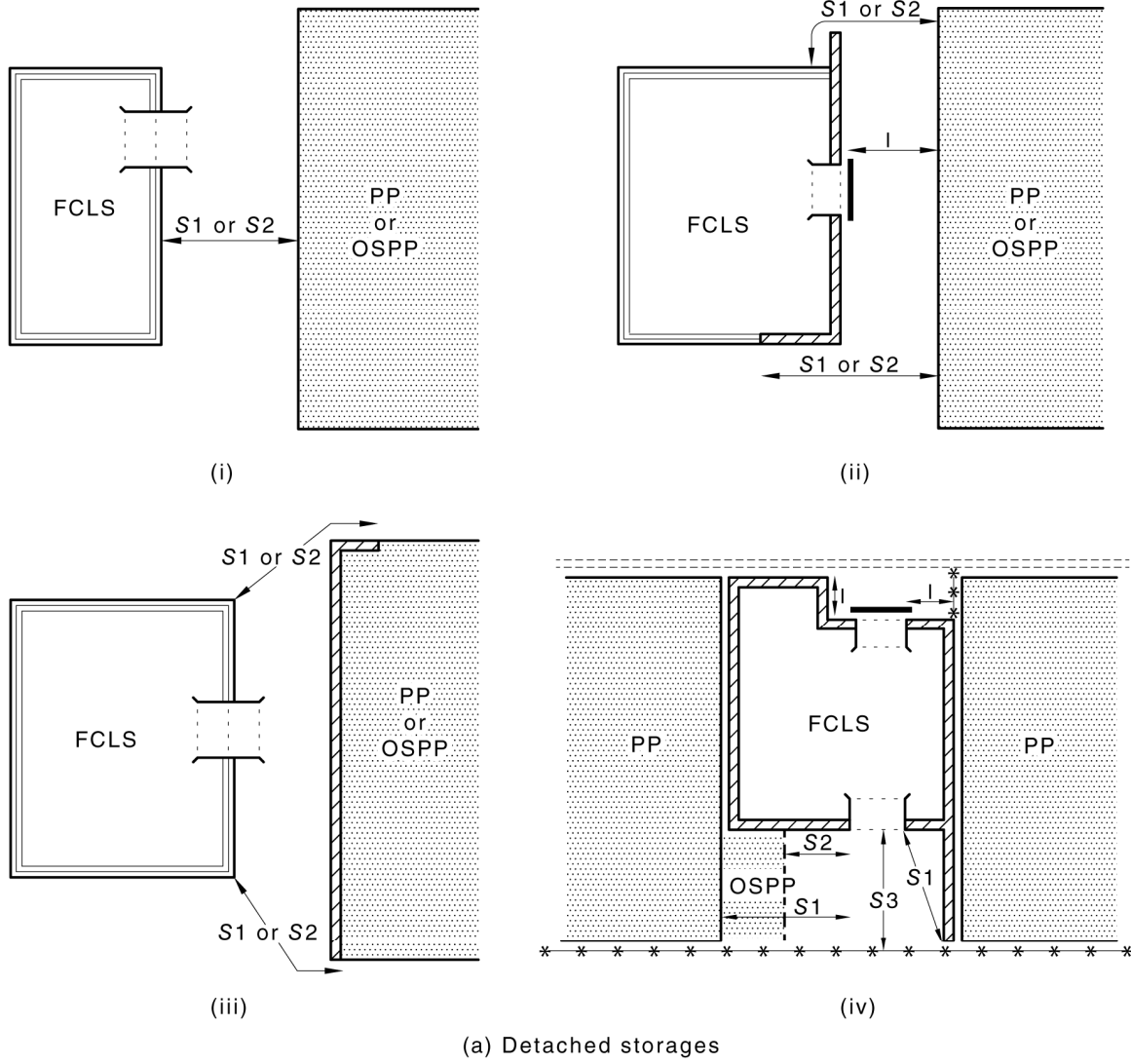

NOTE A fire door has been added to (b)(i).

FIGURE 4.1 (in part) TYPICAL PACKAGE STORES—TYPES AND LOCATIONS

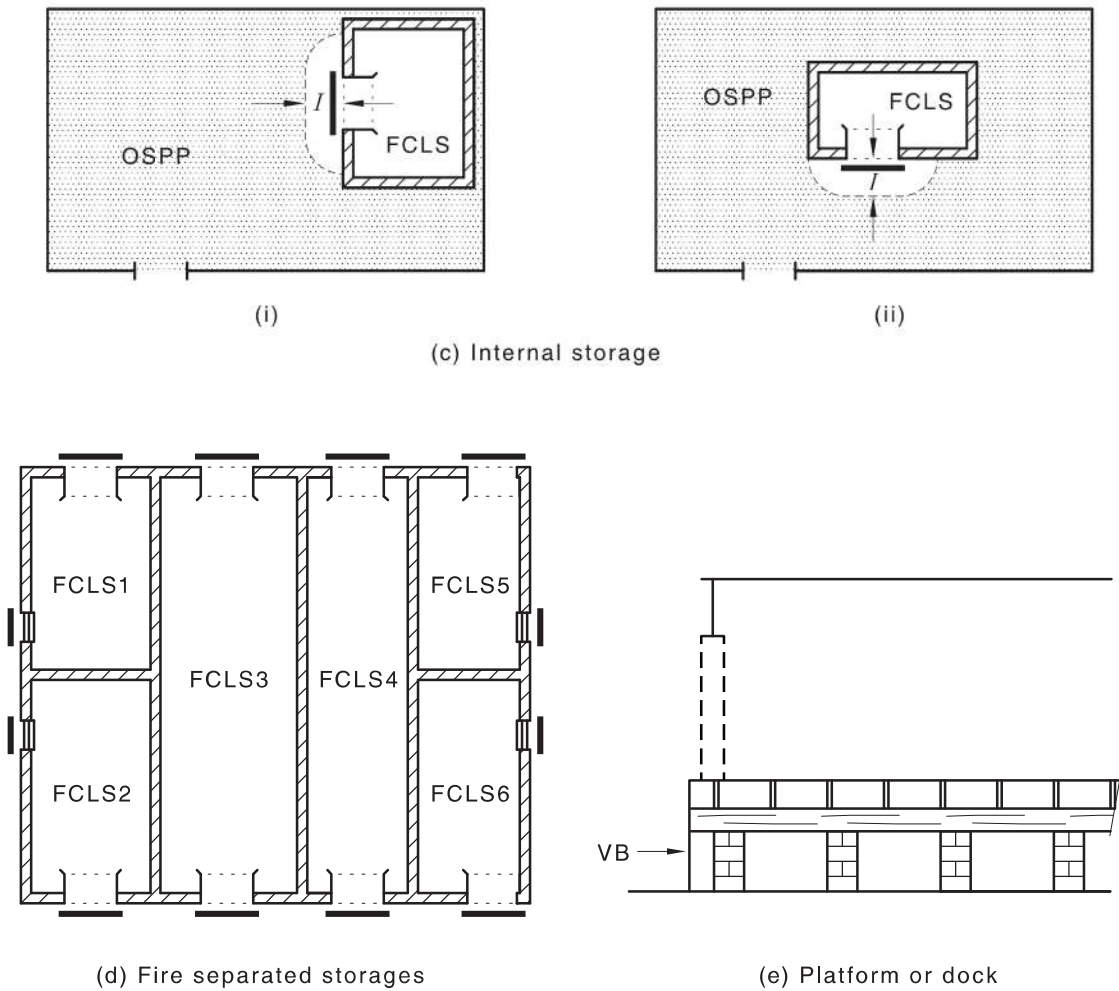

SEPARATION DISTANCES

- I* Ignition source distance
- S1 Protected place distance
- S2 On-site protected place distance
- S3 Boundary distance

LEGEND:

- | | | | |
|--|---------------------------------------|---------------------------|---------------------------------------|
| | Fire wall | | Property boundary |
| | Wall, not fire-rated | | Street boundary |
| | Fire door | | Opening, no fire door |
| | Bund wall | All structures are roofed | |
| | Boundary of facility (not fire-rated) | FCLS | Flammable or combustible liquid store |
| | Ramp | OSPP | On site protected place |
| | | PP | Protected place |
| | | VB | Vapour barrier |

FIGURE 4.1 (in part) TYPICAL PACKAGE STORES—TYPES AND LOCATIONS

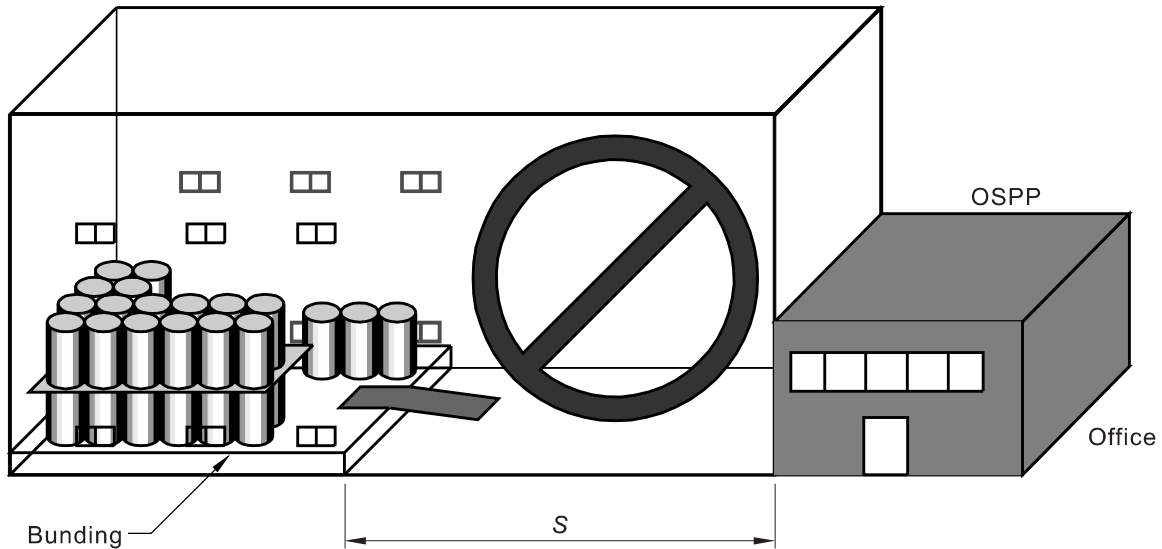

NOTE: Separation distance to OSPP cannot be measured via the air space from the compound to the office, as this is an attached storage. Unlike some other classes of dangerous goods, there is no provision for an area within a building to be a flammable liquid package store.

LEGEND:
 OSPP = on-site protected place
 S = separation distance

(a) Package storage compound within a naturally ventilated building

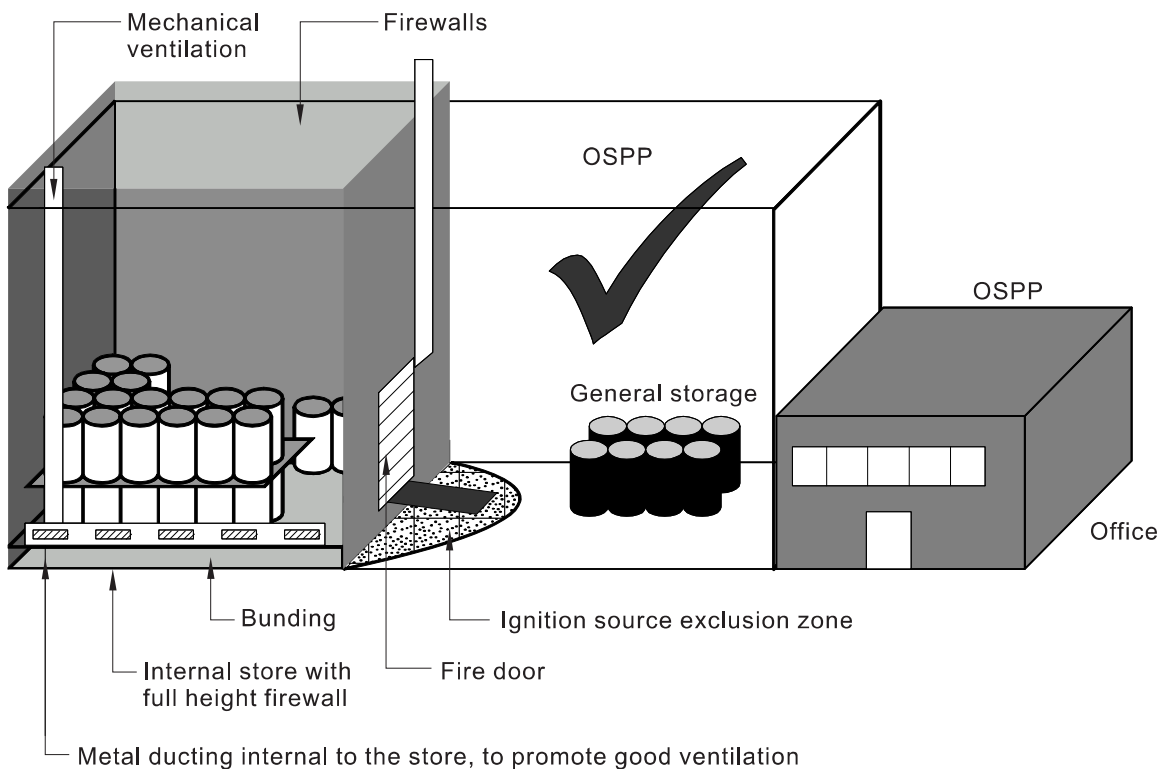

LEGEND:
 OSPP = on-site protected place

(b) Package store having mechanical ventilation and firewalls

FIGURE 4.2 (in part) EXAMPLES OF PACKAGE STORES

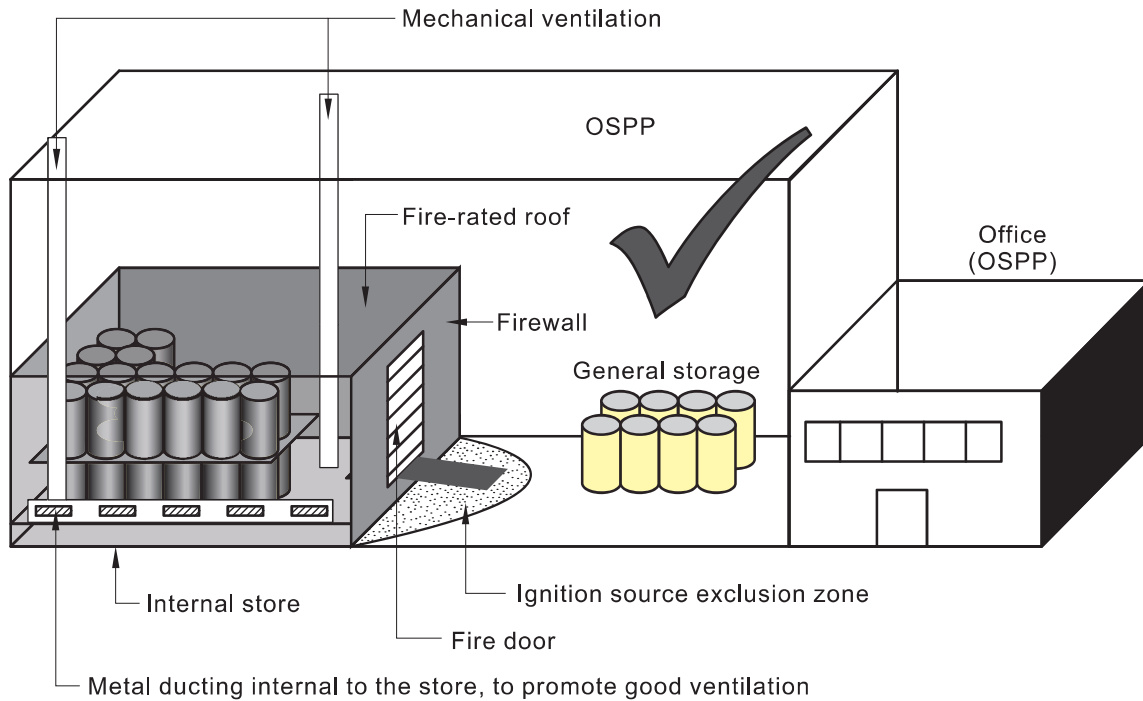

LEGEND:
OSPP = on-site protected place

(c) Package store within a warehouse

FIGURE 4.2 (in part) EXAMPLES OF PACKAGE STORES

4.3 LOCATION AND SEPARATION DISTANCES

4.3.1 Separation distances for package stores

When determining the location for a package store, factors such as infrastructure, firefighting resources, fire brigade access and automation need to be considered.

A store for packages of flammable or combustible liquids shall be located in accordance with the following requirements:

- (a) The minimum separation distance to a protected place (other than an on-site protected place) shall be as given in Table 4.1.
- (b) The minimum separation distance to any on-site protected place shall be as given in Table 4.1, but need not exceed—
 - (i) 15 m for flammable liquids; or
 - (ii) 7.5 m for C1 liquids; or
 - (iii) 3 m for C2 liquids.

Any office within or immediately adjacent to the storage area that is used solely for the direct supervision of the storage is not considered an on-site protected place (see also Clause 4.11).

- (c) The minimum distance to any public place shall be as given in Table 4.2, and Item (a) above.

- (d) The minimum distance to any tank storage shall be either—
 - (i) the distance specified in this Section, regarding the tank as an on-site protected place; or
 - (ii) the distance specified in Section 5, whichever is greater.
- (e) Separation distances shall be measured from the internal perimeter of the bund except where Item (f) applies.
- (f) Where an indoor store has an in-built firewall or vapour barrier, separation distances shall be measured from the nearest potential point of vapour escape, e.g. the outlet of a natural vent or a door.
- (g) Where a fire door connects a storage area with an associated working area, the distance from the fire door to any ignition source shall comply with the relevant requirements of AS/NZS 60079.10.1.
- (h) Where drainage to a separate compound, drainage tank or sump is provided (as in Clause 4.4.3), the separation distances specified in Table 4.1 shall apply, as given below:
 - (i) The separation distance from the storage area itself shall be as required by Items (e) and (f).
 - (ii) Any remote sump, compound or open tank shall be treated as if it were a tank, of a capacity equal to that required for the compound by Clause 4.4.3.
 - (iii) For any open drainage channel, open tank, sump or vent, the separation distances shall be the extent of the hazardous area as determined by AS/NZS 60079.10.1.
- (i) Where there are two or more stores on the same premises and separation distances are to be determined, they shall either be—
 - (i) considered separately, provided that the stores are separated by at least 5 m or the distance given in Table 4.1 for the capacity of the greater of the two; or
 - (ii) considered as the aggregate capacity of the two stores.
- (j) Where flammable or combustible liquids of differing flash points are kept in the one store, the distances shall be those for the packing group or class with the lowest flash point present, but based on the aggregate quantity of all liquids stored.

NOTES:

- 1 Separation distances may be measured around any intervening vapour barriers or firewalls, as described in Clause 3.8 and illustrated in Figure 4.1.
- 2 Adjacent stores which are separated by firewalls having FRLs of 240/240/240, fitted with doors having a FRL of –/240/30, and having no access between compartments may be treated as individual stores when determining separation distances [see Figure 4.1(d)].

4.3.2 Protection of elevated protected places

Protected places located at a higher level or superimposed above a store shall be protected against potential rising flames and heat radiation from any fire in the store below.

4.3.3 Location of internal package stores

Except for cabinets, all internal package stores shall be located on a floor directly accessible from street level or site roadway in the package store.

Because an internal store is usually located within a building which is normally considered an on-site protected place, Clause 4.3.1(b) cannot validly be applied. Clauses 4.3.1(a) and 4.3.1(c) apply from any vent outlet or doorway in the package store.

TABLE 4.1
SEPARATION DISTANCES FROM PACKAGE STORES
TO PROTECTED PLACES

Maximum capacity of liquid storage, m ³ (kL)				Minimum distance m
Class of liquid stored				
Flammable liquid		Combustible liquid		
PG I, PG II	PG III	C1	C2	
0.1	0.5	2.5	5	Unrestricted
1	4	10	20	3
2	8	20	40	4
4	16	40	80	5
7	28	70	140	6
10	40	100	200	7
14	56	140	280	8
20	80	200	400	9
26	104	260	520	10
34	136	340	680	11
42	168	420	840	12
52	208	520	1040	13
64	256	640	1280	14
77	308	770	≥1540	15
170	680	1700		20
310	1240	≥3100		25
500	2000			30
750	≥3000			35
1100				40
1500				45
≥2000				50

NOTES:

- The distances that apply to any intermediate capacity may be obtained by linear interpolation.
- Separation distances may be measured around firewalls and vapour barriers. See Clause 3.8 and Figures 4.1, 4.2 and 4.3.

TABLE 4.2
SEPARATION DISTANCES FROM PACKAGE STORES
OF FLAMMABLE LIQUIDS TO PUBLIC PLACES

Separation from public places to:	Minimum distance, m
Storage area for closed packages of flammable liquids	3
Area where packages of flammable liquids are opened (e.g. for decanting, mixing, filling)	8

NOTES:

- Separation distances may be measured around firewalls and vapour barriers. See Clause 3.8 and Figures 4.1, 4.2 and 4.3.
- Where there is an ignition source on adjacent premises, reference should be made to Clause 3.2.4.
- AS/NZS 60079.10.1 should also be consulted.

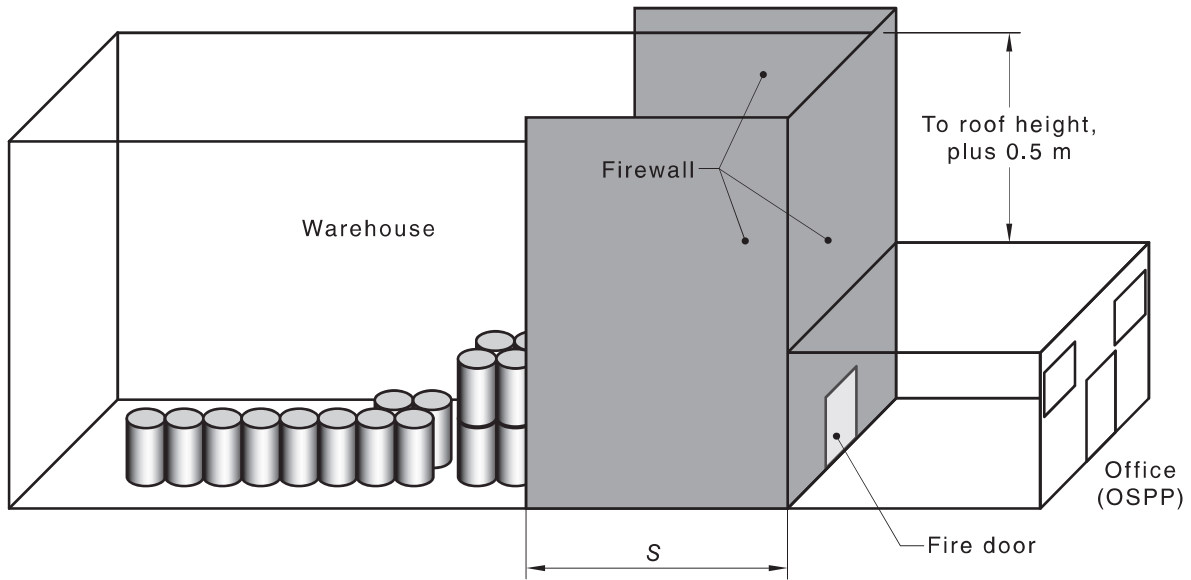

LEGEND:
 OSPP = on-site protected place
 S = separation distance

(a) Where the roof of one of the adjoining buildings is lower than the other building, the firewall extends to 0.5 m above the higher roof and has an FRL of 240/240/240

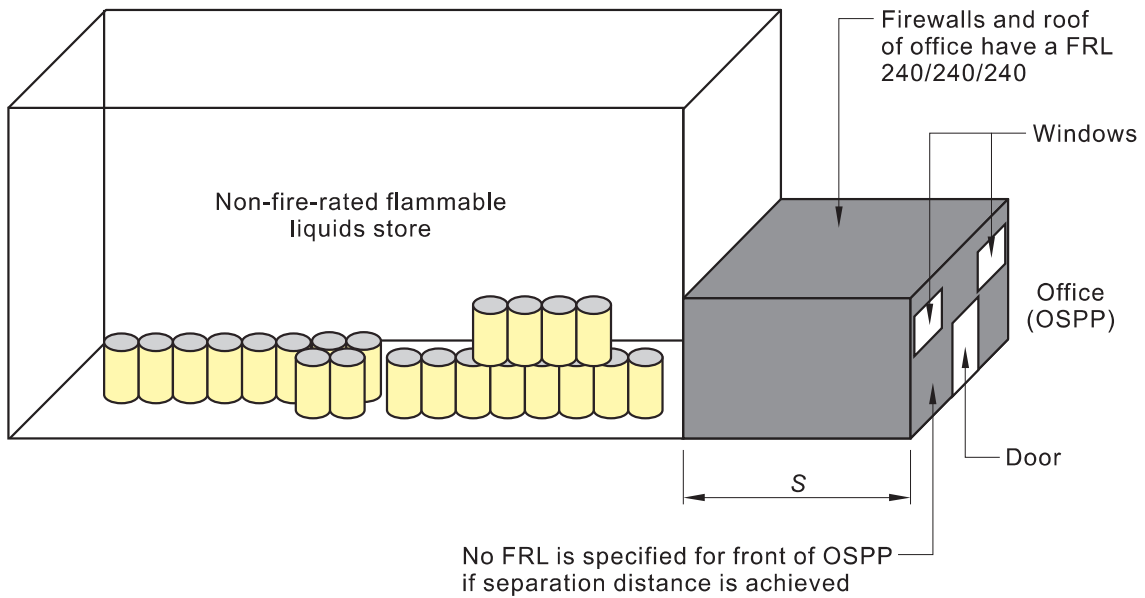

LEGEND:
 OSPP = on-site protected place
 S = separation distance

(b) Where the store is not fire-rated, then the office is to be fully fire-rated (side walls, roof, front wall, door and windows) if separation distance is not achieved

FIGURE 4.3 EXAMPLES OF FIREWALL HEIGHTS

4.4 CONSTRUCTION

4.4.1 General construction

Any package store shall be designed and constructed to be adequate for the purpose in accordance with the following requirements, as appropriate:

- (a) Other than where a fire-rated structure is required, any wall or roof shall be masonry, concrete, or a structure sheeted with non-combustible material, except for any skylights that might be necessary.

NOTE: Non-combustible material on timber frames complies with this requirement.

- (b) Floors forming part of the spillage catchment system shall be impervious, not liable to degradation or to incendive sparking. Suitable materials are concrete and sealed masonry.
- (c) Platform surfaces shall comply with Item (b). The loading face shall be a vapour barrier up to the deck height, extending the full length of the face, and returning at least 1 m along the side at each end.

4.4.2 Construction of internal or attached package stores

A package store that is inside a building, or that shares a common wall with a protected place or an on-site protected place, shall be constructed as follows:

- (a) The separating walls shall be constructed of a material having an FRL of at least 240/240/240. The failure of any component with an FRL of less than 240/240/240 shall not jeopardize the stability of any firewall.
- (b) The floor of the store shall be of reinforced concrete having an FRL of at least 180/180/180.
- (c) The roof of the store shall be of a material having an FRL of at least 180/180/180, unless the walls are taken through the main roof by at least 0.5 m, to provide fire insulation.

NOTE: This limitation is due to the potential difficulties in gaining access for firefighting in such a store.

- (d) Any duct that passes through a storage area shall be constructed of or protected by material having an FRL of at least –/180/180.
- (e) Any occupancy or usage above a flammable liquids store shall be separated by a barrier having an FRL of at least 180/180/180.
- (f) Where the only means of access to an above-ground store of flammable liquids is through an associated working area that is an on-site protected place, the storage capacity shall be limited to 15 000 L, or 100 m², unless an automatic fire suppression system complying with AS 2118.1 is provided.

4.4.3 Spillage containment

Provision shall be made to contain any leaks or spillages, and to prevent them from contaminating the surrounding soil or entering any watercourse or water drainage system. The following requirements apply:

- (a) A spillage containment compound shall be sufficiently impervious to retain spillage and to enable recovery of any such spillage. The compound shall be chemically resistant and fire resistant as far as is necessary to fulfil its functions.

NOTE: Portable bunding units, e.g. banded pallets, or flexible bunding units are not suitable for permanent storage as there are no uniform performance criteria for chemical resistance or fire resistance and they can be easily moved to an unsuitable location. They may be suitable for the short-term holding of damaged packages, or where goods are in transit or in manufacturing and handling areas.

- (b) Pipework that is intended to convey any spilt liquid to a remote holding tank or compound shall be resistant to fire. Flashback into the store or flashover between storage compartments shall be prevented.
- (c) Construction and drainage shall comply with Clauses 5.8.3 and 5.8.6.
- (d) The capacity of the spillage containment compound shall be at least 100% of the volume of the largest package plus 25% of the storage capacity up to 10 000 L, together with 10% of the storage capacity between 10 000 L and 100 000 L, and 5% above 100 000 L.
- (e) If a water-based automatic or manual fire suppression system is installed, the compound capacity shall be increased by a volume equal to the output of the system over 20 minutes.
- (f) Any drainage system shall be capable of carrying the output of the sprinkler system for the number of sprinklers operating at the required operating pressure (refer to AS 2118.1).
- (g) The drainage of any rainwater or fire water to outside the compound shall either be—
 - (i) via a suitable interceptor or separator (e.g. a molecular sieve); or
 - (ii) after sampling and testing of the water.
- (h) Where more than one storage is connected to a common compound, drainage tank or pit, the capacity of the compound shall be equal to the largest compound required for any one store, plus 25% of the capacity of the compounds required for the other stores connected to it.

4.4.4 Doors

4.4.4.1 General

Any doorway through a firewall separating a package store from an on-site protected place shall be provided with a door. Such a door shall—

- (a) be a sliding or an outward-opening, automatic-closing fire door complying with AS/NZS 1905.1, and fitted with a thermal-release device; and
- (b) have an FRL of at least $-/120/30$.

4.4.4.2 Use of non-fire rated doors

The entrance to a detached store with firewalls [as shown in Figure 4.1(a)] does not need to have a fire door if it is separated from any on-site protected place by either of the following:

- (a) The on-site protected place is separated by a distance of at least that given in Clause 4.3.1.
- (b) The on-site protected place is—
 - (i) outside an arc of 100° in either direction of a perpendicular line drawn from the centre of the doorway of the store;
 - (ii) at least 5 m from the nearest point of that doorway; and
 - (iii) not exposed to potential heat radiation from that doorway (see Figure 4.4).

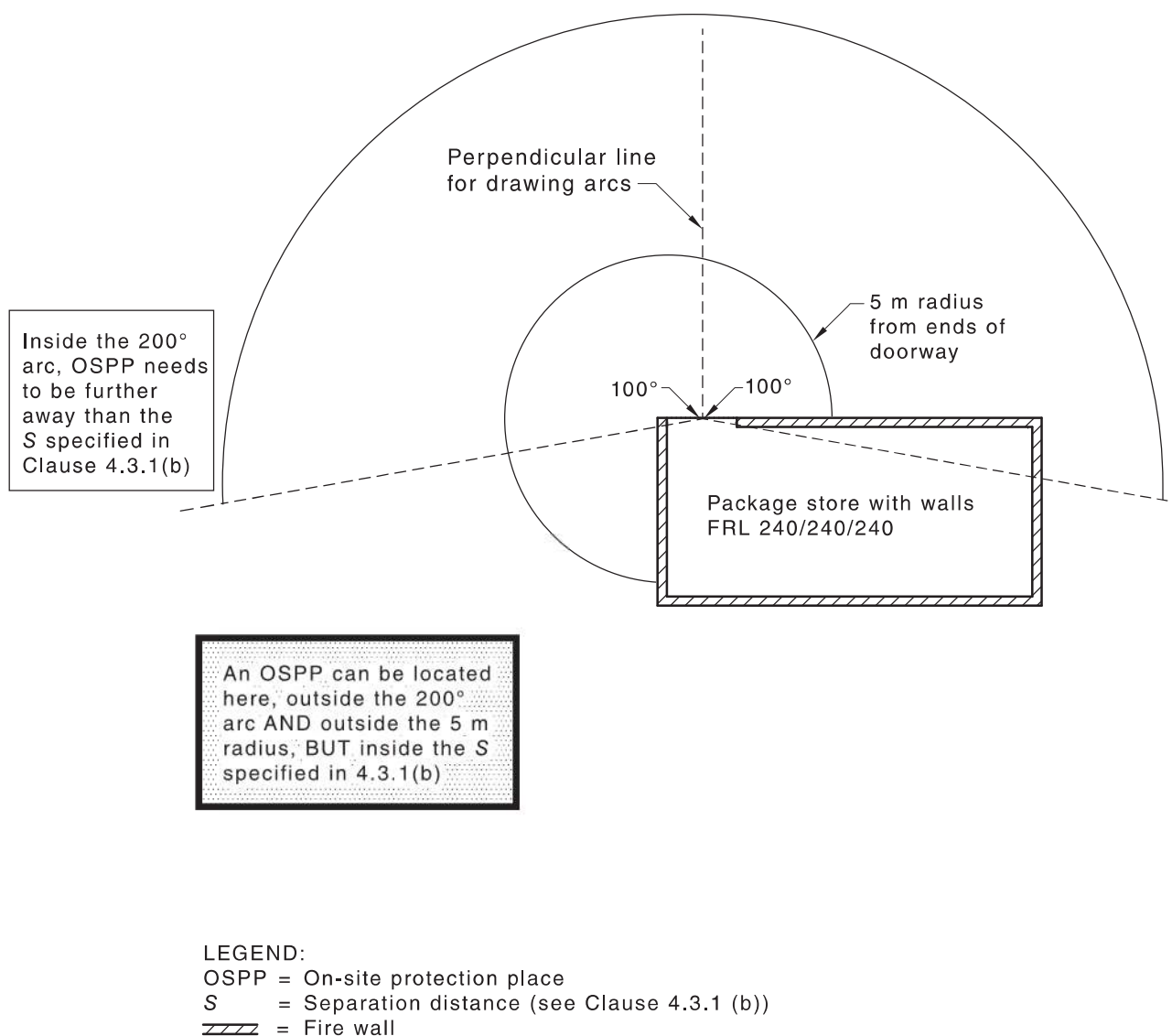

FIGURE 4.4 USE OF NON-FIRE-RATED DOORS

4.4.5 Windows in fire-rated walls

Any window fitted shall be of the same rating as the wall.

NOTE: AS 1288 and AS/NZS 1905.1 include information on the fire resistance of glass.

Windows that are not required to be fire-rated and that face on-site protected places, protected places or public places, shall have toughened safety glass, safety wired glass or equivalent.

NOTE: The exemption for doors given in Clause 4.4.4.2 may be applied to windows if they have safety wired glass or equivalent.

4.5 VENTILATION

4.5.1 General ventilation requirements

Each package store shall be provided with adequate natural or mechanical ventilation, depending on the goods being stored.

The ventilation system shall be sufficient to ensure that any vapours and fumes generated within the store are diluted with, and removed by, air passing through the store.

NOTE: Workplace exposure standards, as published by Safe Work Australia, also apply.

With respect to hazardous area classification, AS/NZS 60079.10.1 shall be consulted.

Stores ventilated in accordance with the following requirements are deemed to comply with this Clause (4.5.1):

- (a) A natural ventilation system that complies with Clause 4.5.4.
- (b) A mechanical ventilation system that complies with Clause 4.5.5.
- (c) A cool room with ventilation that complies with Appendix D.

4.5.2 Additional ventilation requirements for package handling, filling and decanting areas

Where packages are opened, filled, or decanted, additional ventilation shall be provided as necessary to ensure a safe working atmosphere under normal operating conditions.

4.5.3 Vent protection

Any vent opening inside the store shall be provided with barriers in both the inside and outside of the wall where necessary so that it cannot be blocked.

Where a vent passes through a cavity wall, or where the wall is made of cavity bricks or blocks, a metal sleeve shall be provided to prevent vapour from leaking into the cavities.

4.5.4 Natural ventilation

4.5.4.1 General

A natural ventilation system shall comprise one of the following, as appropriate to the design of the store:

- (a) At least two walls completely open to outside atmosphere [see Figure 4.5(a)].
- (b) A wall of wire mesh, or of fixed louvres, lattice or the like, having at least 50% of its area as openings, is considered completely open.
- (c) One wall completely open to outside atmosphere, with no other vents, provided that the distance to, and the length of, the opposite wall do not exceed the length of the open wall [see Figure 4.5(b)].
- (d) Vents in one external wall, provided that the wall is at least 6 m long and the opposite wall is not more than 5 m away from it.
- (e) One wall open to atmosphere as in Item (b), and vents in one opposite or adjacent wall [see Figure 4.5(c)].
- (f) Vents in two opposing walls [see plan view in Figure 4.5(d)].

NOTES:

- 1 Vents should be located along the longest sides of the building and should be positioned to limit areas where there is no effective ventilation. With large stores, consideration should also be given to providing additional vents on adjacent walls and/or providing vents larger than 0.1 m² or 0.15 m².
- 2 Figure 4.5 provides examples of naturally ventilated stores.

4.5.4.2 Vent size and location

Where vents are required, they shall consist of openings immediately above the upper limit of the spillage compound, each having a net free area of at least 0.1 m², or 0.15 m² where open packages are present, with an equal area of openings above the highest package, positioned to ensure effective movement of air.

There shall be one low-level vent in each 3 m of length of wall, or in each 1.4 m of length of external wall where there is only one external wall. Where only one such vent is required, it shall be central in the length of wall.

NOTE: An equivalent open area of ventilation is acceptable, provided the required vent area per wall is maintained.

Any storage platform (except a solid-filled type) shall be provided with underdeck ventilation by means of vent openings on opposite sides having an area of at least 0.1 m² for each 1.2 m of length.

Figure 4.5 provides examples of naturally ventilated stores.

4.5.4.3 *Natural ventilation for package stores containing combustible liquids only*

Where the store contains packaged combustible liquids only, the upper level ventilation described above may be omitted and the surface area of the lower vents may be reduced by half.

4.5.5 Mechanical ventilation

Any mechanical ventilation system for package stores containing flammable liquids shall comply with the requirements set out below:

- (a) The termination points within the room for both the fresh air supply and the draw-off ducts shall be—
 - (i) immediately above the upper limit of the spillage compound; and
 - (ii) on opposite walls.

The distance between any two inlets or any two outlets shall not exceed 5 m.

NOTES:

- 1 It is recommended that the outlets be located along the longest side of the building for optimum effect.
- 2 If a single fan system is adopted, the fan should be in the exhaust duct.
- 3 The air supply may be in the form of natural ventilation in an external wall at low level, as described in Clause 4.5.4.1.

- (b) If the ventilation system incorporates fans on both the supply and exhaust ducts, the capacities of the fans shall be so adjusted that the room is under negative pressure.

NOTE: The capacities of the fans on the exhaust ducts should be greater than those on the supply ducts.

- (c) The system shall be capable of exhausting 0.3 m³ per square metre of floor area per minute or 5 m³/min, whichever is the greater, and the air velocity at the air supply outlet shall exceed 300 m/min.

NOTE: Vapours from flammable liquids are heavier than air, so the ventilation system should be designed to scavenge vapours from the lower parts of the store.

- (d) The system shall be provided with an airflow failure-warning device.
- (e) Any intake or exhaust duct shall terminate in open air at least 2 m from any opening into a building, or 4 m from the outlet of any chimney or flue and 3 m above the ground. The external termination of any inlet duct shall be at least 5 m from the external termination of any exhaust duct.
- (f) Any duct that passes through a building other than the storage area shall be constructed of or protected by material having an FRL of at least -/180/180.

NOTE: A common enclosure may be used for both intake and exhaust ducts.

- (g) The system shall be designed so that it operates—
 - (i) continuously; or
 - (ii) whenever work is being carried out in the store; or
 - (iii) whenever a person is in the store.

- (h) Fans shall be suitable for hazardous areas. Relevant potential ignition sources, e.g. frictional sparking, static electricity and hot spots, shall be taken into account when selecting and installing fans (refer also to AS/NZS 60079.14, AS/NZS 1020 and the AS/NZS 60079.10.1). Fan blades and nearby components shall be made of materials that have minimal potential for giving off sparks when struck.

NOTE: Materials known to be unsatisfactory are steel with steel, or steel with aluminium or aluminium-magnesium alloys.

A mechanical ventilation system for package stores containing only combustible liquids shall comply with Items (a) to (g) above, except that for Item (c) the air volume may be reduced by half.

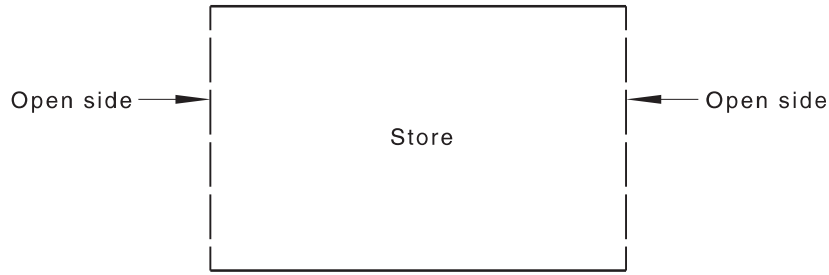

(a) Stores having opposite external sides open

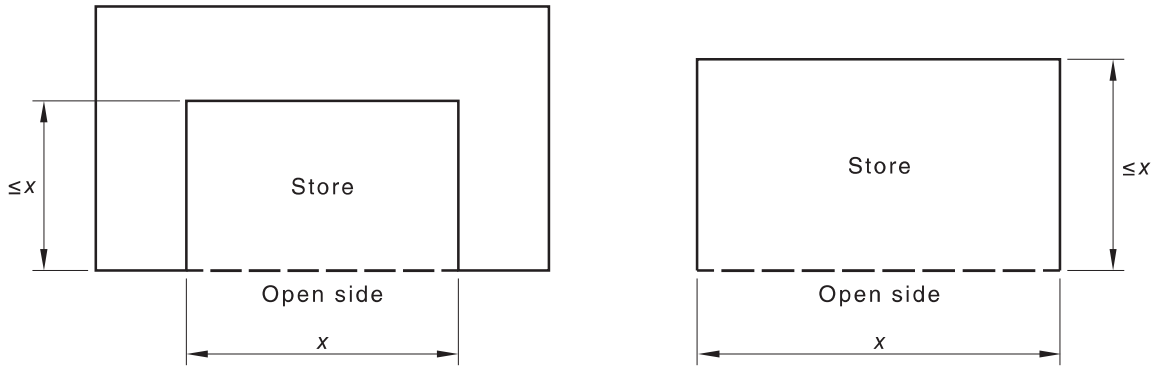

(b) Stores having one external side open

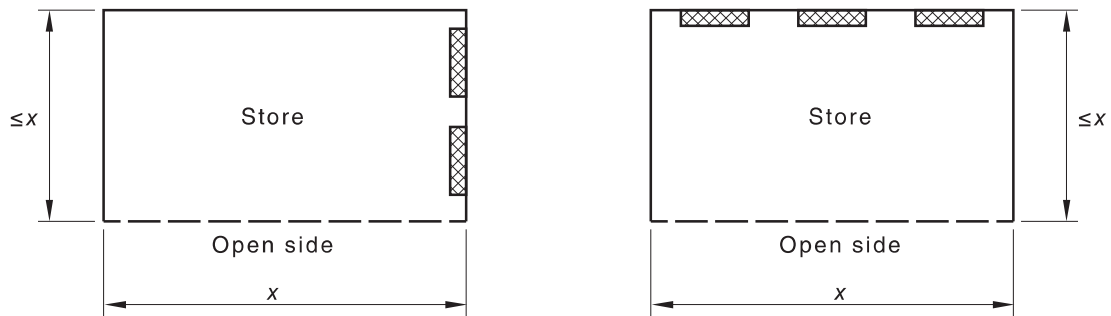

(c) Stores having one external side open and vents in adjacent or opposing external walls

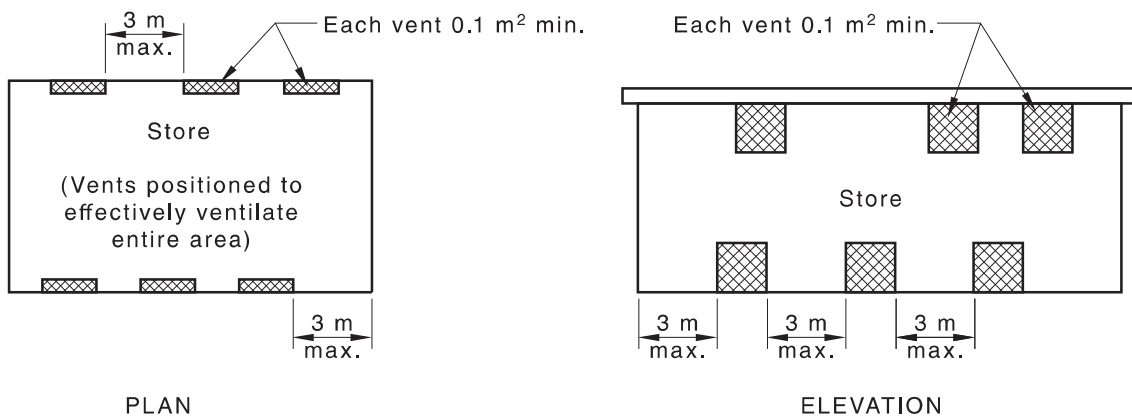

(d) A Store having vents in one pair of opposite external walls

FIGURE 4.5 (in part) EXAMPLES OF NATURALLY VENTILATED STORES

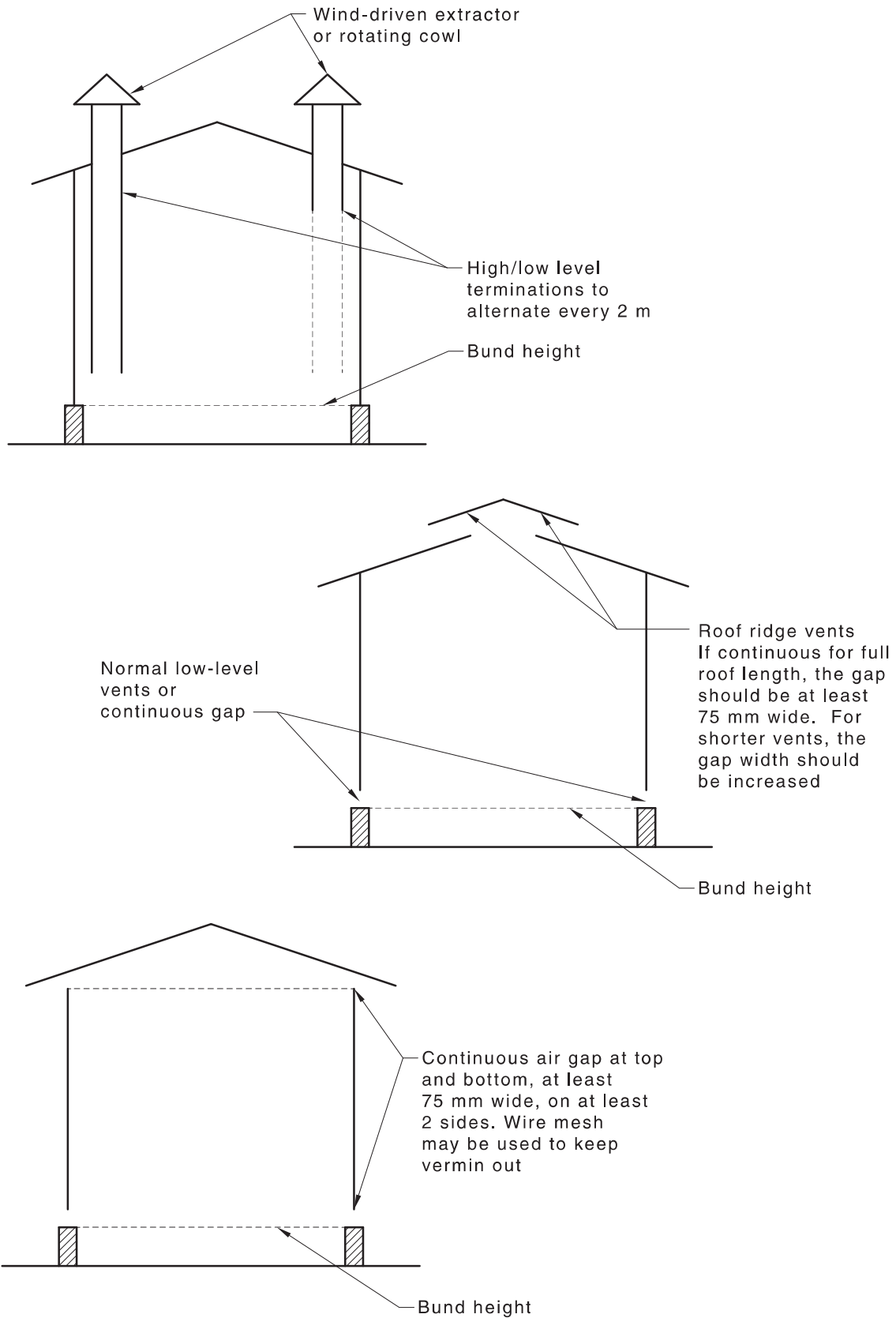

(e) Alternative methods of ventilation

FIGURE 4.5 (in part) EXAMPLES OF NATURALLY VENTILATED STORES

4.6 GENERAL REQUIREMENTS

Except for storage cabinets (as described in Clause 4.9), stores for packaged flammable or combustible liquids shall comply with the following requirements, as appropriate:

- (a) Packages shall be kept in such a manner that they cannot fall and cause spillage outside the compound.

NOTE: Packages of flammable liquids should be kept at least 600 mm from the inner edge of the bund wall or restraints provided to prevent falls or spills occurring outside the compound.

- (b) Clear access shall be available to the store.
- (c) The following items shall be provided within 10 m of, but not nearer than 2 m, to stores where packages are opened:
 - (i) Eye wash facilities complying with AS 4775.
 - (ii) Water for the washing of hands.
- (d) A safety shower shall be installed where—
 - (i) the quantity of liquids exceeds 2000 L; or
 - (ii) required by risk assessment or regulation.

NOTE: Safety showers should comply with AS 4775.
- (e) All relevant requirements of Section 10 shall apply.
- (f) Packages on pallets shall not be stacked more than three high unless purpose-built racking or a suitable restraint is provided (see Clause 9.14.3).

4.7 STORAGE OF IBCs

Intermediate bulk containers (IBCs) of up to 1.6 m³ capacity may be stored in a package store provided that—

- (a) they are not connected to any piping or product delivery system;
- (b) the ventilation and spillage control provisions are adequate to cater for the quantity of IBCs being stored;
- (c) the IBCs are stored at least 1 m from the bund or edge of the store, unless splash shields or baffles constructed from compatible, non-combustible materials are used;
- (d) they comply with the ADG Code; and
- (e) the IBCs are not stacked more than two high unless purpose-built racking is provided.

4.8 STORAGE IN FREIGHT CONTAINERS

Except for the purposes of loading and unloading, freight containers shall not be used for the storage of flammable and combustible liquids in packages, unless they have been modified to comply with the requirements Sections 3 and 4 with respect to separation, segregation, ventilation and spillage containment.

The following additional requirements apply to the storage of flammable and combustible liquids in such freight containers:

- (a) A freight container shall not be used as both a storage and a workshop area.
- (b) Before the freight container is first used as a store, the floorboards shall be inspected for any significant contamination from previous spills or leaks.

NOTE: Contaminated floorboards could react dangerously with any further spills or leaks or evolve harmful vapours in a fire.

- (c) There shall be a passage at least 800 mm wide inside the freight container. Such a passage shall be clearly marked, e.g. by yellow lines painted on the floor.
- (d) AS/NZS 60079.10.1 shall be consulted. No electrical equipment shall be installed in a hazardous area, unless it complies with AS/NZS 60079.14.
- (e) No point within the freight container shall be more than 6 m from the freight container's exit door.
- (f) Each door of the freight container shall be able to be opened from inside the freight container. Any external lock shall be deactivated.

4.9 STORAGE IN STORAGE CABINETS

4.9.1 General

This Clause (Clause 4.9) applies to the storage of flammable and combustible liquids in cabinets.

Clauses 4.9.2, 4.9.4, 4.9.5, 4.9.6, 4.9.7 and 4.9.8 provide requirements that apply to all storage cabinets. Clause 4.9.6 provides requirements for the location of cabinets depending on their capacity. Clause 4.9.3 applies to the construction of cabinets having a capacity of more than 250 L.

The maximum capacity of any cabinet shall be 850 L.

4.9.2 Cabinet construction

The following requirements apply:

- (a) The walls, floor, door and roof shall be of double-walled sheet steel construction, with a space of at least 40 mm between the walls.
NOTE: This space may be either an air space or filled with non-combustible insulation.
- (b) Any gaps around the doors and into the space between the walls shall be sealed as far as is necessary to prevent the spread of flame or heat radiation.
- (c) The inner base of the cabinet shall form a liquid-tight compound at least 150 mm deep, and shall be designed to prevent the compound from being used as a storage space.
- (d) Any shelves shall be perforated to permit free air movement, and shall be capable of carrying the maximum possible load.
- (e) All leakage shall be directed into the lower compound.
- (f) All cabinet doors shall be self-closing, close-fitting and held shut automatically by catches at two or more points.
- (g) Where doors are equipped with a device to hold them open when necessary, they shall be released automatically as soon as the temperature exceeds a nominal 80°C.
- (h) The materials of any components that are critical to the cabinet's structural integrity shall not melt at temperatures less than 850°C. Seals or gaskets are accepted, but avoid their use if their failure could affect the protective function of the cabinet.

4.9.3 Additional construction requirements for cabinets exceeding 250 L capacity

Any cabinet having a capacity greater than 250 L shall be constructed in accordance with Clause 4.9.2 and the following additional requirements:

- (a) The top of the cabinet shall be no more than 2 m above floor level.
- (b) All external surfaces shall be constructed from sheet steel at least 1 mm thick.

- (c) The cabinet's lower compound shall be capable of holding at least 25% of the design capacity of the cabinet or the volume of the largest package able to be stored in the cabinet, whichever is the greater.

4.9.4 Cabinet marking

Each cabinet shall be marked with—

- (a) the name and address of the manufacturer or, for imported cabinets, the distributor within Australia;
- (b) the maximum storage capacity;
- (c) a Class 3 dangerous goods label with sides of at least 250 mm nominal length; and
- (d) a sign bearing the words 'NO SMOKING, NO IGNITION SOURCES WITHIN 3 m' in lettering at least 50 mm high.

All signs and markings shall be clearly visible when the cabinet doors are closed.

4.9.5 Ventilation provisions

Where ventilation is installed, it shall be designed so that vapours are prevented from escaping into any room. Any ventilation exhaust shall be to the outside atmosphere and in a location which allows the safe dispersal of vapours and is away from any ignition sources (see Clause 4.5).

4.9.6 Cabinet location

The following requirements apply to the location of cabinets for flammable and combustible liquids:

- (a) Cabinets shall be located so that they do not impede escape in an emergency.
- (b) Cabinets having a capacity greater than 250 L shall not be installed in residential or accommodation buildings, commercial buildings, hospitals, aged care buildings or school buildings.
- (c) Cabinets having a capacity greater than 250 L shall only be installed on floors that have direct access from street or ground level.
- (d) Cabinets having a capacity greater than 250 L shall not be placed nearer than 3 m to any wall that is common with another room, unless that wall is constructed of concrete or masonry to ceiling height or 3 m above the top of the cabinet (whichever is less) and 3 m to either side of the cabinet.
- (e) The aggregate capacity of cabinets shall not be greater than—
 - (i) 850 L per 250 m² on a ground floor area; or
 - (ii) 250 L per 250 m² on other floors.
- (f) Each aggregate quantity given in Item (e) shall be separated by at least 10 m.
- (g) A storage cabinet may be used for outdoor storage, provided that adequate protection against weather, corrosion and traffic damage is provided.

4.9.7 Exclusion of ignition sources

There shall be no ignition sources within the cabinet. Where flammable liquids are stored, ignition sources shall be excluded from the area outside the cabinet to a distance of 3 m measured laterally, and from floor level to a height of 1 m above any opening in the cabinet, including the door, or a distance determined in accordance with AS/NZS 60079.10.1.

Where only combustible liquids are kept in the cabinet, ignition sources shall be avoided within the spaces specified above.

4.9.8 Storage in storage cabinets

The following operational requirements and recommendations apply:

- (a) Persons shall be prevented from entering the cabinet.
- (b) Drums shall not be stacked more than two high if they are greater than 60 L capacity.
- (c) Only one drum of more than 60 L capacity should be kept in a horizontal (decanting) position at any time.
- (d) Only closed packages, or those fitted with a tap, should be stored in the cabinet.

4.10 ACTIVITIES WITHIN PACKAGE STORES

Activities such as mixing, blending, degreasing, tinting, package filling or co-storage with other goods shall not be carried out within the package store unless a risk assessment has been conducted and a risk management plan prepared.

The plan shall specify the conditions under which these other activities can be carried out without significantly increasing the level of risk (e.g. of ignition, fire or explosion), or creating any new hazards (e.g. vapour release).

NOTES:

- 1 See also Clause 4.5.2 regarding ventilation.
- 2 Appendix E outlines issues to be considered when doing a risk assessment.

4.11 OFFICES WITHIN PACKAGE STORES

Where an office is inside a store for flammable and combustible liquids, the following requirements shall apply:

- (a) The office shall be used only for activities directly associated with the store's operation.
- (b) The office shall be regarded as a restricted area.
- (c) The office shall be provided with a means of escape other than through the area where the liquids are stored.
- (d) All office windows facing the store shall be of shatterproof glass (e.g. toughened safety glass or safety wired glass).
- (e) Personnel employed in the office shall not be exposed to any vapours from the store.
- (f) Where a hazardous area (assessed in terms of AS/NZS 60079.10.1) extends into the office (e.g. through a door, window or other opening), the relevant requirements for ignition sources in hazardous areas shall apply.

SECTION 5 STORAGE IN TANKS

5.1 SCOPE OF SECTION

This Section sets out requirements and recommendations for the storage of flammable or combustible liquids in tanks. The provisions of this Section are additional to those given in Section 3.

Where tanks contain differing classes of liquid, all the provisions of this Section shall apply to the liquid of the lowest flash point.

Requirements for tank vehicle loading areas are given in Section 8. Requirements for IBCs of less than 1.6 m³ capacity are given in Clause 4.7.

Where flammable potable spirits are stored in bulk, Appendix F provides requirements that are alternative to this Section. However, the general principles given in this Section may be applied to such storages.

Provisions for spillage containment at power stations and grid transformers are described in Appendix G.

NOTE: See Figure 5.1 for an illustration of the terms used in this Section.

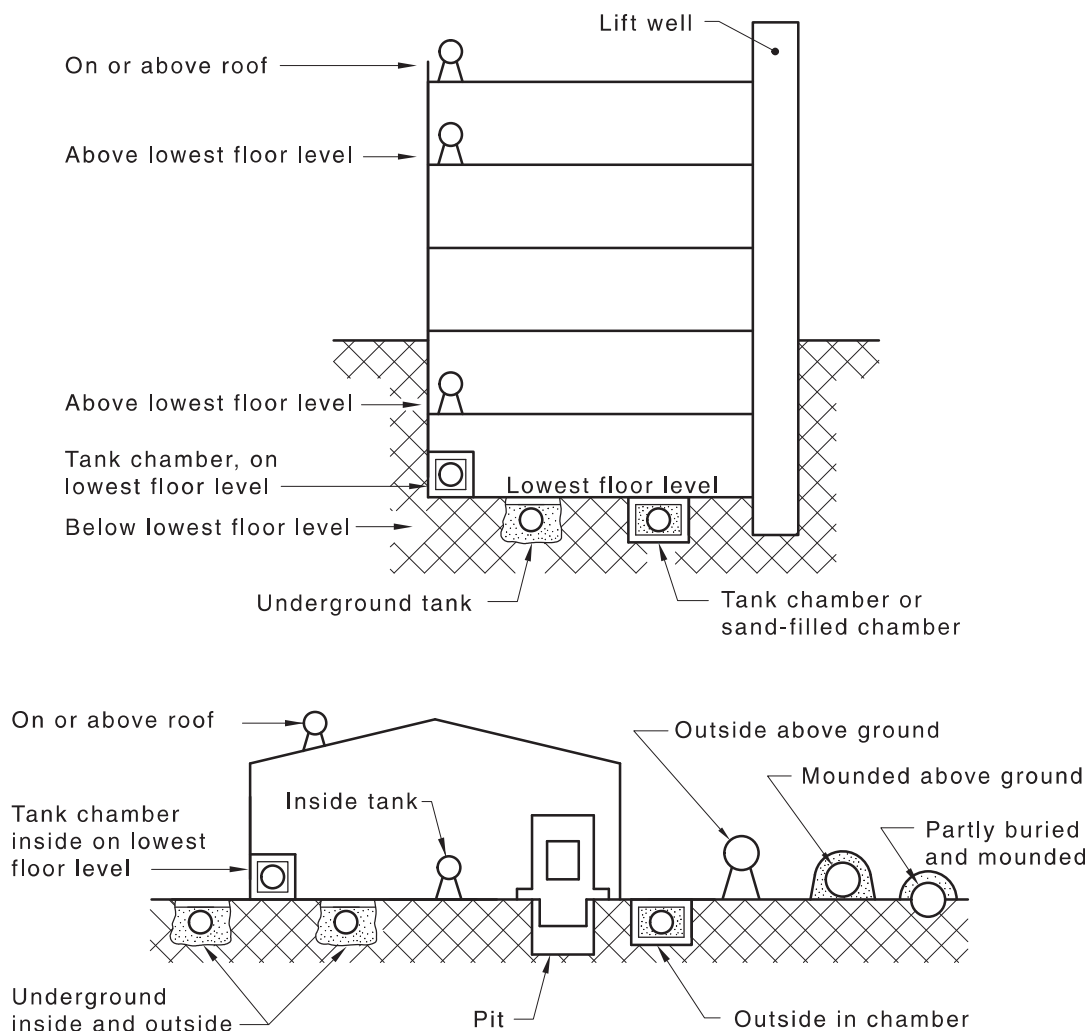

FIGURE 5.1 ILLUSTRATIONS OF TERMS RELATING TO TANK LOCATIONS

5.2 GENERAL REQUIREMENTS

5.2.1 Design and construction of static storage tanks

A static storage tank shall be designed and constructed to comply with AS 1692 or an equivalent Standard for the category of tank appropriate to the application.

NOTE: Where the filling pressure, static head or vapour pressure in the ullage space exceeds 35 kPa, the tank plate thickness and end design should be stress-checked in accordance with API Std 620 or other recognized Standards.

A Category 1 tank shall not be used for flammable liquid.

NOTES:

- 1 AS 1692 requires that certain essential information be provided by the purchaser to enable the correct tank to be supplied.
- 2 In some circumstances it may be necessary to use a pressure vessel that complies with AS 1210.

5.2.2 Markings

Each tank in an installation shall be distinguished from any other tank by individual identification numbers or letters as part of a system for verifying the contents of each tank at any time and shall meet the following criteria:

- (a) For above-ground tanks:
 - (i) Markings shall be displayed on the outside walls of the tanks and shall be not less than 500 mm in height for tanks having a diameter of 6 m or greater. For tanks of less than 6 m diameter the markings shall be not less than 150 mm in height.
 - (ii) The bottom of the markings shall be above the crest of the main bund and any plant, equipment and piping on or above the bund.
 - (iii) Where possible, the markings shall be clearly visible from main alternative access points likely to be used by the fire authority.
 - (iv) Where there is a foam pumphouse or manifold for the control of firefighting foam, one such marking shall be clearly visible from that point or its close proximity.
 - (v) Where there is a cluster of vertical tanks of 6 m diameter or greater or tanks are not separated as given in Table 5.3, the tanks shall have similar markings affixed to the roof with the numerals 6 and 9 underbarred.
 - (vi) All markings shall be of a colour contrasting with that of the tank.
- (b) For underground tanks, the fill, dip and vapour recovery point for each tank shall be marked to identify it. Guidance is provided in AS 4977.
- (c) All tanks shall be marked with the appropriate warning placard as required by relevant regulation.

5.2.3 Change of tank contents

Where there is a change of contents of a tank, the requirements of this Standard applicable to the new contents shall apply.

5.2.4 Pipework

The following requirements apply to pipes and flexible hoses:

- (a) Pipes and pipe joints shall be constructed from a material that is resistant to attack by, and is compatible with, the liquid under all service conditions. Where pressure piping is used, it shall comply with AS 4041.

- (b) All pipes shall be adequately protected from physical damage. Where plastic piping is used, it may also require electrostatic protection (refer to AS/NZS 1020 and IEC 60079-32-2).

NOTES:

- 1 Plastics may be subject to environmental stress cracking, 'ageing' and UV degradation. They are more susceptible to physical damage than steel, aluminium or stainless steel. Their physical properties can be seriously affected by extremes of ambient temperature, particularly when used above ground.
 - 2 Manufacturers' data and testing should be consulted for guidance when selecting piping for the installation conditions.
 - 3 Such protection may require the installation of physical barriers.
- (c) All above-ground pipes shall be colour-coded or labelled.
- (d) Pipework shall be well-supported and protected from potential traffic damage.
- (e) Flexible hoses shall not be used, except at transfer points. Where such hose is used, it shall be constructed of material that is resistant to attack by, and is compatible with, the liquid being transferred. The length of the hose shall be kept to a minimum.

NOTE: The use of bellows joints should be avoided (see also Clause 6.2.2).

5.2.5 Roofs over tanks

This Clause applies to a tank or group of tanks that are located under a roof. It is not intended to apply to indoor tanks, which are addressed in Clause 5.6.

Where there is a roof over a tank or group of tanks, the following requirements apply:

- (a) All tanks shall be vented above roof level.
- (b) Tanks shall be located and separated in accordance with Clauses 5.7 and 5.8.
- (c) If, under normal operations, personnel are to work on the tank (e.g. when dipping the tank contents) a vertical clearance of at least 2.5 m shall be provided between the top of the tank or landing and the roof.
- (d) Separation distances shall be based on the aggregate volume of all of the tanks under the same roof, and shall be measured from the edge of the roof.
NOTE: This requirement does not apply if the roof is designed to burn or collapse quickly in a fire.
- (e) The effect of the roof upon hazardous atmosphere zoning shall be considered when designing such storage.
- (f) Provision shall be made for access, egress, and the application of cooling water.

Consideration should be given to—

- (i) the impact that the roof might have on heat dissipation and on the dispersal of flammable vapours;
- (ii) any restrictions that might be placed on firefighting as a result of the tanks being roofed; and
- (iii) the mode of failure of the roof and its supporting members under fire conditions.

5.2.6 Tanks on or above a roof

Any tank that is to be installed on or above a roof shall be of double-walled construction, with the outer shell overflow pipe directed to a remote tank, sump or compound having a capacity at least equal to the tank capacity. A tank overflow pipe shall be provided, having sufficient capacity to return the full capacity of the filling pump to the remote tank, sump or compound without spillage or over-pressuring the storage tank. An overflow alarm shall be fitted, audible at the filling point.

5.3 STORAGE TANK FILL POINTS

5.3.1 Fill connection

The fill connection to a storage tank that is filled from a tank vehicle shall incorporate a liquid-tight connection unless the filling method employs a hand-held trigger nozzle with a non-latching feature. A cap or cover shall be provided for the fill point.

5.3.2 Location of fill point

The fill point for any tank intended to be filled from a tank vehicle shall comply with the following requirements:

- (a) The fill point shall be readily accessible.
- (b) The fill point shall be protected from accidental damage.
- (c) The fill point for any tank containing a flammable liquid shall be in open air and no ignition sources shall be located within the hazardous area defined in accordance with AS/NZS 60079.10.1.
- (d) Where practicable, the fill point for any tank containing a combustible liquid shall be outside. If it is inside, it shall be not more than 2 m from a building entrance useable by a tank vehicle, and shall not be in a boiler room, furnace room, or an elevated temperature area.

NOTE: Fill points located inside a building should not be operated unless the building has sufficient alternative access and egress points to ensure the safe evacuation of personnel in an emergency.

- (e) The fill point for a tank shall be located so that a tank vehicle is not required to enter the tank compound to make a delivery.
- (f) For any tank containing a flammable liquid, the location shall be such that the tanker can stand wholly off any public road, except where allowed under the ADG Code.
- (g) Each fill point shall be clearly identified. For petroleum products, fill points shall comply with AS 4977.
- (h) The areas around the tank fill point and the vehicle hose connection point shall be impervious to the product.

For restrictions on the loading of vehicles, see Section 8.

NOTE: Where a service station is located near sensitive facilities (including where vulnerable people are concentrated such as schools, hospitals, aged care accommodations, child care and large entertainment venues), consideration should be given to preventing any potential large spill of fuel during a road tanker unloading operation impacting on these nearby sensitive facilities.

5.3.3 Liquid level indication

It shall be possible to monitor or gauge the amount of liquid in any tank intended to receive a delivery. This gauge or monitor shall also show the normal fill level of the tank. The following shall apply:

- (a) The normal fill level shall not exceed 95% of tank capacity (overfill level).
- (b) The provision of only a dipstick without an alarm is acceptable for liquid level monitoring of tanks—
 - (i) up to 25 000 L tank capacity for combustible liquids;
 - (ii) up to 5000 L tank capacity for flammable liquids; or
 - (iii) underground tanks filled by gravity.

- (c) All other tanks shall have a suitable high level alarm (LAH) set at a maximum of 97% of tank capacity. This alarm is the first stage overfilling protection, and shall be set to warn when the normal fill level has been exceeded. It shall not be used to control filling.
- (d) Any tank filled by gravity shall be fitted with an automatic flow limiting device which reduces the flow rate into the tank by 98% when the normal fill level of the tank has been attained.

NOTE: Hydraulic shock can result from sudden valve closures and any static electricity that might accumulate due to a high flow rate should be dissipated.

- (e) A contents gauge or monitoring device together with a LAH, remote from the tank, shall be provided at the fill point, or where the tank filling operation is monitored and controlled (e.g. a control room), in the following circumstances:
 - (i) Where the tank is located within a building or under a building and the dip point is more than 8 m from the entrance to the building or otherwise inaccessible.
 - (ii) Where the tank is in a tank chamber and access to the dip point is prevented.
 - (iii) Where the tank is out of direct sight of the attendant monitoring filling flow controls.
 - (iv) Where Category 6 tanks are filled from ship to shore, from a refinery, or similar high volume transfers (e.g. 100 m³/h).

A1

- (f) In addition to the LAH, Category 6 tanks filled from ship to shore, from a refinery, or similar high volume transfers, shall incorporate a physically and electrically independent high-high level alarm (LAHH). It will warn of a failure of some element of a primary (process) control system. It shall be set at or below the tank rated capacity to allow adequate response time to terminate the transfer before loss of containment/damage occurs.

NOTE: Response times should be based on maximum flow rates and generally should not be more than 10 minutes and be determined by a risk assessment.

NOTES:

- 1 Any alarm system should be appropriately maintained with a safety testing regime.
- 2 For Category 6 tanks, the level settings may be established on a risk assessment methodology to ensure that the maximum liquid level of the tank does not compromise the design parameters of the tank.
- 3 When a high level is reached, consideration should be given to shutting down the pump via a suitable interlock.

5.3.4 Filling of elevated tanks

If the fill point is at or below the highest likely level of liquid in the tank or piping system, the fill connection shall be a dry-break type, incorporating a manual shut-off valve immediately upstream of the coupling. Where the fill point is beyond the security fence around the installation, a non-return valve shall be incorporated in the piping system at the security fence.

NOTE: An end-of-line assembly comprising a non-return valve, manual shut-off valve and cap with witness hole may be used in lieu of a dry-break coupling.

5.4 VENTING

5.4.1 General requirements

A tank manufacturer will not normally be able to finalize the design and size of the vent provision without consultation concerning the conditions of installation, filling, and operation, and the type of product to be stored.

Tanks, other than Categories 1 and 2, shall not be installed unless the owner holds design documentation confirming compliance with the relevant Standard, or it can be demonstrated that the tank is fit for service.

Each tank shall be fitted with a vent or vents in accordance with the following provisions:

- (a) A free vent or a pressure-vacuum (PV) vent designed for the type of liquid being stored.
- (b) An emergency vent when the conditions of Clause 5.5 apply.
- (c) Vapours shall be safely discharged outdoors unless their recovery and treatment is otherwise required.
- (d) The vents shall be separate from the filling pipe except for a Category 1 tank.
- (e) API Std 2000 is the basis for the requirements of this Clause (5.4.1). Appendix H provides a metric version of parts of API Std 2000, but in cases of dispute the original Standard in imperial units will be the basis for decision.

NOTES:

- 1 Tanks of Categories 1 and 2 are intended for specific applications; the former for oil supply to domestic heaters, the latter for minor storage in open-space locations. Neither is intended for industrial use, and their vent provision could be inadequate for the filling and draw-off rates likely to be required in such usage.
- 2 Classification of tanks is in accordance with AS 1692.

5.4.2 Vent capacity

The size of any free vent or pressure-vacuum vent shall be such that pressure or vacuum resulting from filling, emptying, or atmospheric temperature change will not cause the maximum allowable stress for the tank to be exceeded, nor the tank to collapse. These requirements shall be met by one of the following:

- (a) For a Category 1 or Category 2 tank, the vent provided with the tank in accordance with AS 1692 shall be deemed to be suitable for the types of installations for which the tanks are intended (see Note 1 to Clause 5.4.1).
- (b) The vent size for a Category 3, 4, 5 or 6 tank installed above-ground shall comply with the relevant requirements of API Std 2000.

NOTE: The vent size of a Category 4 above-ground tank may be in accordance with Table 5.1 (see also Clause 5.4.1 regarding vent size).

- (c) The vent size of a Category 4 tank installed underground shall be at least that specified in Table 5.2.

TABLE 5.1
FREE VENT SIZE FOR ABOVE-GROUND
CATEGORY 4 TANKS

Liquid flow rate L/min	Minimum vent diameter, mm			
	Flammable		Combustible	
	Filling	Withdrawing	Filling	Withdrawing
250	32	32	32	32
500	32	37	32	37
750	32	42	32	42
1000	32	46	32	46
1500	32	54	32	54
2000	34	60	32	60
2500	38	66	32	66
3000	41	71	32	71

NOTES:

- The diameters specified in this Table are the minimum allowable internal diameters, as derived from API Std 2000, assuming a maximum tank pressure of 17.5 kPa and a vacuum 0.5 kPa below ambient pressure.
- To use this Table, check the minimum permitted diameter for both the filling and withdrawing rates for the particular installation and use a pipe which will give at least the larger of the two resultant diameters.

TABLE 5.2
FREE VENT SIZE FOR UNDERGROUND CATEGORY 4 TANKS

Maximum filling or withdrawing flow rate L/min	Nominal pipe size*		
	Pipe length, m		
	15	30	60
750	32	32	32
1000	32	32	40
1500	32	40	50
2000	40	40	50
2250	40	50	50
2500	50	50	50
3000	50	50	80
4000	50	50	80

* Minimum nominal size in millimetres, and quoted on the basis that the actual bore will not be less than the nominal value quoted. It includes allowance for seven elbows.

NOTE: In the normal case of petrol flowing by gravity through a 100 mm hose, the flow rate will be of the order of 2000 L/min.

5.4.3 Vent piping

Any vent piping between the tank vent connection and the discharge point shall comply with the following requirements:

- The vent pipe shall fall consistently back to the tank at a slope of at least 1 in 100.
- A vent pipe shall not pass through building foundations but may be embedded in concrete that is part of other building construction. Joints in vents shall be—
 - of such quality as to prevent vapour leaking; and

- (ii) located so that any leaking that might occur, is prevented from accumulating inside or transferring into cavity walls, ceilings or enclosed spaces.
- (c) An underground vent pipe shall be either embedded in a concrete slab or laid in the earth.

If the vent pipe is laid in the earth, it shall be—

- (i) located at least 300 mm below ground level;
- (ii) surrounded by clean washed sand;
- (iii) suitably protected if the area is subject to vehicular traffic;
- (iv) designed and installed to provide flexibility to accommodate settlement; and
- (v) protected from corrosion.
- (d) Where vent piping penetrates a fire-rated wall, it shall be installed so as to ensure that the fire resistance of the wall is maintained.
- (e) The vent pipe and terminal shall be located or protected so that they are not liable to damage resulting from normal activities.
- (f) Joints in vent piping shall be sealed to prevent liquid or vapour release and tested to a minimum hydrostatic pressure of 35 kPa or the operating pressure of the vent unit, whichever is the greater.

NOTE: Vent pipes may be connected together to form a common vent line, provided that the area of any common vent line is not less than the sum of the cross-sectional areas required for the individual vents connected to it, and that cross-contamination will not affect adversely the use of the contents of either tank.

- (g) Where several tanks are interconnected by a common venting system and the vapours in the vapour are within the explosive range, measures shall be taken to prevent the possibility of flashback or flame propagation through the system from one tank to another, e.g. by the use of flashback arresters, barometric dampers, nitrogen inerting or ensuring that the vapour concentration is always above the explosive range.

NOTE: Additional requirements may be necessary where vapour recovery is adopted.

5.4.4 Vent outlet location

The discharge point of a vent shall comply with the following requirements:

- (a) The vent discharge point shall be located laterally at least 4 m for flammable liquids and 2 m for combustible liquids from any opening into a building, e.g. window, door, ventilator, airconditioner or a mechanical vent intake to reduce the possibility of the entry of nuisance vapour. The vent shall be located such that the opening into a building shall be outside the hazardous area to AS/NZS 60079.10.1.
- (b) The vent discharge point shall be located at least 4 m above ground level except for direct-vented tanks of Categories 1 or 2.

NOTE: The vent for any above-ground tank may discharge at a point at least 150 mm above the top of the tank, provided that other requirements for tank and vent locations are met.

- (c) Where the tank is to be filled by gravity flow from a tank vehicle, the vent discharge point for the tank shall be at least 4 m above ground level at the fill point and in all circumstances shall be higher than the tank vehicle.
- (d) Where a Category 1 to 5 tank is to be filled by pumping from a tank vehicle—
 - (i) the vent pipe or overfill point shall terminate in view of the filling operator; or
 - (ii) the tank shall be fitted with a high level alarm audible to the filling operator.

Notwithstanding other requirements in this Clause (5.4.4), a vent provision may be connected to a vapour recovery or collection system.

NOTE: When filling rates are high, the velocity of the discharging vapour may be high enough to carry it a considerable distance. In such cases, particular attention should be paid to direction of discharge, to vapour diffusion and to potential ignition sources, especially for flammable liquids.

5.4.5 Vent terminals

The discharge end of a vent shall be protected from the ingress of foreign material by means of a protective cage or fitting. Where a tank contains flammable liquid and the vapour within the ullage space of the tank is within explosive limits, a flame arrester or similar device shall be fitted. Any such protective cage, flame arrester or other means shall not reduce the required effective vent area or create undue back-pressure within the tank.

NOTE: A flame arrester incorporating a bronze or stainless steel wire mesh having openings not greater than 600 μm is acceptable.

5.4.6 Application of pressure-vacuum vents

A pressure-vacuum vent shall not be used on any tank of Categories 1, 2 or 3, unless the tank has been specifically designed and tested as prescribed in AS 1692 for use with such a vent.

A pressure-vacuum vent shall not be fitted to any Category 4 underground tank, except as part of a vapour recovery system.

5.4.7 Setting of pressure-vacuum vents

The settings of any pressure-vacuum vent shall be such that the pressure and vacuum limits, as given in the Standard to which the tank has been designed and tested, are not exceeded.

For tanks in Categories 4 or 5 designed and tested in accordance with AS 1692, the pressure setting shall be such that the test pressure of the tank is not exceeded under maximum normal venting conditions. The vacuum setting shall be such that the internal pressure does not fall below a pressure of -0.5 kPa gauge. On such tanks, the setting of the pressure-vacuum vent shall be more than 7 kPa below that of the emergency vent.

5.5 EMERGENCY VENTING

5.5.1 Application of emergency venting

Emergency venting shall be provided for any Category 3 (above 2500 L), 4, 5 or 6 above-ground tank having a fixed roof and containing a flammable liquid or which, though it contains a combustible liquid, is in the same compound as a tank containing a flammable liquid.

Clauses 5.5.2 and 5.5.3 do not apply to:

- (a) Any open-top tank with pontoon, floating or lifter roof.
- (b) Any fixed-roof tank that has an internal floating roof and free air vents of equal or greater area than that required for emergency venting.
- (c) Any fixed-roof tank having a diameter of 12 m or greater (see Clause 5.5.2).

5.5.2 Capacity and size of emergency vents

The capacity of any emergency vent shall be in accordance with API Std 2000 (see Appendix H).

For a vertical tank having a diameter of 4 m or less, a weak roof-to-shell joint (a frangible roof) shall not be regarded as an acceptable alternative to an emergency vent. For vertical tanks having diameters greater than 4 m but less than 14 m, a frangible roof may not be effective and its use should be proven by calculation; alternatively, emergency venting shall be provided.

For a vertical tank having a diameter of 14 m or greater, the use of a frangible roof is acceptable.

NOTE: Emergency venting is designed to release vapour created by external fire, e.g. in a bund, whereas frangible roofs are designed to also relieve internal explosions.

If the emergency vent is of a simple construction such as a manhole cover with long bolts or equivalent, its size may be determined by reference to Appendix H. For more complex emergency vents, the capacity data supplied by the manufacturer shall be used in the selection of the vent.

Emergency venting, when different liquids are in tanks in the same compound or in different compartments of a multi-compartment tank, requires venting for each tank to be calculated using the formula in Paragraph H2.2, Appendix H. This is particularly important when alcohols or other chemicals that are not common hydrocarbons covered by Table H2 (which is based on hexane) are involved.

5.5.3 Pressure setting of emergency vents

The pressure setting of any emergency vent shall be such that under maximum emergency venting conditions the pressure in the tank shall not exceed the limits given in the Standard to which the tank has been designed.

NOTE: Where both an emergency vent and a pressure-vacuum vent are required, there should be sufficient difference between the pressure settings of the two vents to ensure that the emergency vent will open only under emergency conditions when the normal venting provisions have been exceeded.

5.6 LOCATION AND CAPACITY OF INDOOR TANKS

5.6.1 General

Tanks containing flammable or combustible liquids that are an integral part of blending, mixing or processing equipment are exempt from this Clause (5.6). However, the fire protection requirements given in Clause 11.11.1 shall apply to such tanks.

NOTE: See Figure 5.1 for illustrations of terms relating to tank locations.

5.6.2 Flammable liquids

Any tank that is located within the confines of a building and contains quantities of flammable liquid greater than minor storage shall be either—

- (a) a double-walled tank below the lowest floor level, installed in accordance with Clause 5.12; or
- (b) a single-wall tank placed in a tank chamber or a sand-filled chamber, in accordance with Clause 5.13; or
- (c) a tank having integral secondary containment with an FRL of 240/240/240 and complying with Clause 5.9.

Where an adjoining basement, tunnel, pit or the like extends below the level of the tank, the sand-filled chamber method shall be used.

NOTES:

- 1 It is recognized that because of special circumstances on a particular site, other forms of installation may provide an equivalent level of safety.
- 2 In some areas any storage of flammable liquid within or under a building of any type may be prohibited.
- 3 Requirements for liquid level indication are given in Clause 5.3.3.

5.6.3 Class C1 liquids

5.6.3.1 Tanks having a capacity of 1000 L or less

Tanks having a capacity of 1000 L or less may be installed anywhere within the building, provided that—

- (a) such tanks are not interconnected;
- (b) provision is made to contain the spread of any small leak or spill; and
- (c) such tanks are separated from each other, and from any other tanks, by at least 3 m.

5.6.3.2 Tanks having a capacity greater than 1000 L

Any tank having a capacity greater than 1000 L capacity shall be—

- (a) a double-wall tank buried in accordance with Clause 5.12; or
- (b) installed on or below the lowest floor level of a building, in a tank chamber in accordance with Clause 5.13; or
- (c) a tank having integral secondary containment with an FRL of 240/240/240 and complying with Clause 5.9.

Any such tank shall be installed on or below the lowest floor of the building.

5.6.4 Class C2 liquids

Any storage of Class C2 liquids in tanks within a building shall comply with the following requirements:

- (a) The capacity of each tank that is located on the lowest floor level shall not exceed 60 000 L.
- (b) Not more than 10 000 L shall be stored on any floor above the lowest floor level.

5.7 SEPARATION OF ABOVE-GROUND TANKS

5.7.1 Application

The tank spacing requirements of this Clause (5.7) shall apply to both outdoor and indoor locations, provided that the latter are permitted by other limiting requirements.

5.7.2 Separation distance from tank to protected places, security fences or to on-site protected places

A tank or tanks shall be located so that the following minimum separation distances are maintained:

- (a) To security fences and on-site protected places, Table 5.3.
- (b) To a protected place beyond the site boundary, Table 5.4.
- (c) Except where provided with cooling water in accordance with Appendix I, the layout of tanks storing flammable liquids (or combustible liquids within the same compound as flammable liquids) shall be such that any tank is accessible on at least two sides from an access road outside the bund.

The separation distance to a protected place on an adjacent property may be measured across the property boundary as if the boundary did not exist. Where there is no protected place on the adjoining property the installation may be located in accordance with Item (a). In all cases, if alterations on the adjacent property result in a breach of the requirements for separation distance, the installation shall be modified or relocated to restore compliance, or taken out of service.

TABLE 5.3
SEPARATION DISTANCES FOR TANKS TO SECURITY
FENCES AND ON-SITE PROTECTED PLACES

Separation required from tank to	Minimum distance, m*		
	Flammable liquid	Combustible liquid	
		C1	C2
Fill points†, platforms or package storage	Diameter of the tank or 15 m, whichever is less, but not less than 6 m	Diameter of the tank or 7.5 m, whichever is less, but at least 3 m	Unrestricted, determined by the compound
Office buildings, warehouses, manufacturing and processing areas, workshops or amenities blocks on the same premises	Distance required by Table 5.4, but need not exceed 15 m	Distance required by Table 5.4 but need not exceed 7.5 m	
Security fence‡	Diameter of the tank or 15 m, whichever is less, but not less than 6 m or the distance obtained from Table 5.4, whichever is the lesser	Diameter of the tank or 7.5 m, whichever is less, but at least 3 m	

* Refer to the various rules for alternative distances when vapour barriers are used.

† Points for filling packages, drums or tank vehicles and not the fill point into the storage. Where the liquid being transferred and the liquid in the adjacent storage under consideration are of different classes, determine the separation as if both were of the lower flash point of the two.

‡ For distance to boundaries, see Clause 3.2.5.2.

TABLE 5.4
SEPARATION DISTANCES FOR TANKS
TO OFF-SITE PROTECTED PLACES

Maximum capacity of any tank, m ³ (kL)				Minimum distance m
Flammable liquids		Combustible liquids		
PG I, PG II	PG III	C1	C2	
0.25	0.5	2.5	5	Unrestricted
1	4	10	20	3
2	8	20	40	4
4	16	40	80	5
7	28	70	140	6
10	40	100	200	7
14	56	140	280	8
20	80	200	400	9
26	104	260	520	10
34	136	340	680	11
42	168	420	840	12
52	208	520	1040	13
64	256	640	1280	14
77	306	770	≥1540	15
170	680	1700		20
310	1240	≥3100		25
500	2000			30
750	≥3000			35
1100				40
1500				45
≥2000				50

NOTES:

- 1 For distances above 3 m, the distance applicable for any intermediate capacity may be obtained by linear interpolation.
- 2 For separation distances for a cluster of tanks, see Clause 5.7.5.

5.7.3 Distance between vertical tanks for flammable liquids

The distance between any two adjacent vertical tanks that contain flammable liquids shall be as follows (except as otherwise provided in Clause 5.7.5):

- (a) If neither tank exceeds 6 m in diameter, the distance between them shall be at least either one-third of the diameter of the larger tank or 1 m, whichever is the greater.
- (b) If one of the tanks is more than 6 m but neither is more than 20 m in diameter, the distance between them shall be at least one-half of the diameter of the larger tank.
- (c) If one tank is more than 20 m in diameter, the distance between it and any other tank shall be at least 15 m.

5.7.4 Distance between vertical tanks for combustible liquids

The distance between any two adjacent vertical tanks that contain combustible liquids shall be as follows:

- (a) For Class C1 liquids, at least either one-sixth of the sum of their diameters or 1 m, whichever is the greater, except as otherwise provided in Clause 5.7.5.
- (b) For Class C2 liquids, at least 1 m.

5.7.5 Clusters of tanks

Vertical tanks having a diameter greater than 3 m but not exceeding 10 m may be grouped in a cluster with reduced tank-to-tank spacing, provided that—

- (a) the distance between any two tanks is at least 1 m;
- (b) the total cross-sectional area of all tanks in the cluster does not exceed 320 m²;
- (c) the distance separating any such cluster from any other above-ground tank or cluster of tanks is at least 15 m for flammable liquids or at least 7.5 m for combustible liquids;
- (d) where the total cross-sectional area of the tanks in any such cluster exceeds 30 m², and one or more tanks contain flammable liquid, all tanks in the cluster are provided with foam fire protection in accordance with Clauses 11.13.1 and 11.13.2; and
- (e) when the required compound capacity and clearances from other structures is being calculated, such a cluster is regarded as being one tank of aggregated volume containing liquid of the lowest flash point present.

5.7.6 Horizontal tanks

The following requirements apply to the storage of liquids in horizontal tanks:

- (a) Horizontal tanks shall comply with AS 1692 and the requirements of this Standard.
- (b) The distance between horizontal tanks shall be at least 600 mm. Where horizontal tanks are adjacent to vertical tanks, the distance requirements for vertical tanks shall apply.
- (c) Tanks shall not be arranged end-to-end unless the potential for end failure and the resulting exposure hazard has been taken into account when determining the tank's location.

NOTE: Tanks may be arranged in parallel (side-by-side) in a row.

5.7.7 Mixed products

Where liquids of differing flash point are stored, the following requirements shall apply:

- (a) Where stored within the same compound, the separation distance between tanks applicable to the liquid of the lowest flash point present shall apply to each tank within that compound.
- (b) Where two compounds are separated by a bund, each tank in each compound shall be considered separately in its relationship to each tank in the adjacent compound. In each case, the separation distance shall be that applicable to the liquid of the lower flash point actually present in either of the tanks under consideration.

5.8 BUNDS AND COMPOUNDS

5.8.1 Requirements

Provision shall be made to contain any leakage or spillage from the tank storage facility and to prevent it from contaminating the surrounding soil or from entering any watercourse or water drainage system.

Any above-ground tank shall be installed within a compound, except where the quantity of liquid stored is within that allowable as minor storage in Table 2.1, or where the tank has integral secondary containment complying with Clause 5.9.

5.8.2 Capacity

The net capacity of a compound shall be at least 110% of the capacity of the largest tank or 25% of the total capacity of all tanks within the bund whichever is the greater. If two or more tanks are operated as a single unit, then the capacity of all such tanks shall be used when calculating the capacity of the compound.

NOTE: For Category 6 tanks, the capacity can be taken as the tank rated capacity.

When designing and constructing an earthen bund, account shall be taken of subsidence in the construction materials. In no case shall the bund be less than the nominated capacity. In addition, original height markers shall be installed on earthen bunds.

5.8.3 Design and construction

A compound and its associated bund shall comply with the following requirements:

- (a) It shall be sufficiently impervious to retain spillage and to enable recovery of any such spillage; buried HDPE, geosynthetic clay liners, concrete or other equivalent materials are deemed to be suitable materials.

When earthen bunds are used, consideration shall be given to the minimization of penetration of the bund surface, because of permeability, in the event of a spill.

- (b) In a fire situation, the bund shall retain the structural integrity, which includes any bund wall joints and penetrations. Such joints and penetrations shall include suitable fire resistant fillers in combination with metal waterstops.
- (c) Any bund or compound floor shall be designed to withstand the hydrostatic head when full.
- (d) Any earthen wall 1 m or more in height shall have a flat section at the top at least 600 mm wide.
- (e) The slope of any earthen wall shall be consistent with the angle of repose of the material from which the wall is constructed.
- (f) A bund shall not be higher than 1.5 m above interior grade unless means for safe and rapid entry and exit are provided.
- (g) Any pipe that passes through a bund shall be designed to prevent excessive stresses as a result of settlement or expansion resulting from fire exposure. The joint between the pipe and the bund shall be sealed to prevent leakage.
- (h) The location of a bund relative to the closest tank shall be such that the top inside perimeter of the bund is not inside the crest locus limit specified in Figure 5.2, except where it can be demonstrated that a reduced distance would be appropriate due to viscosity or other considerations.
- (i) Where flammable liquids are stored, the distance from the top inside perimeter of the bund to protected places or on-site protected places shall be at least one half of the specified separation distance given in Table 5.4 or 15 m, whichever is less.
- (j) Any bund with a Category 6 tank containing flammable liquids PG I or PG II products, which is filled from either ship to shore or from a refinery, or similar high-volume transfers, shall be fitted with a suitable flammable liquid vapour detection system which shall alarm at 20% LEL or lower. Alternatively, a suitable bund hydrocarbon liquid level detection system shall be installed.

NOTE: In addition, consideration should also be given to tank top design and to allow the safe re-routing of overflowing liquids.

NOTES:

- 1 It is preferable to have moderately high bunds, rather than shallow bunds, so as to minimize the area of fuel burning in the event of a fire.
- 2 Consideration should be given to access between groups of bunded areas for emergency vehicle access.
- 3 Alternative methods of construction may be used to ensure containment of spills and tank shell leaks.

5.8.4 Compound subdivision

Where the aggregate capacity of the tanks in any compound exceeds 10 000 m³, intermediate bunds of at least half of the average height of the main bunds or 600 mm, whichever is the lesser, shall be provided so that any subdivision so created contains tanks having an aggregate capacity not exceeding 10 000 m³, or a single tank if such tank exceeds that capacity.

5.8.5 Total storage per compound

Except for a single tank, the maximum total aggregate volume of flammable liquids stored within any one compound shall be 60 000 m³ where any tank has a fixed roof, or 120 000 m³ where only floating-roof tanks are used.

5.8.6 Compound drainage

A compound shall be drained in accordance with the following requirements:

- (a) The drainage provision shall slope away from any tank to a sump which is in turn drained from the lowest level either by gravity or by pumping. In the former case, a manually controlled normally-closed valve shall be provided; in the latter case, the pump shall be manually controlled.
- (b) The drain from one compound discharge shall not drain into another.
NOTE: Subdivisions within compounds may be interconnected if arranged to have individual isolating valves.
- (c) Any valve controlling the drainage from a compound shall be located outside the bund except for the valves for intermediate sub-compounds. The valve shall be of a type in which the distinction between the open and shut positions is obvious, and shall incorporate a provision to be locked shut when not actually draining [see Clause 9.2.9(f)].
- (d) The discharge from any sump which could contain flammable or combustible liquid shall be through an interceptor appropriate to the product, readily accessible for inspection, located outside the compound, and designed to prevent the discharge of flammable or combustible liquids to any natural watercourse, public sewer, or drain.
- (e) The design capacity of any drainage system shall be at least the rate of supply of emergency water within the compound as provided in Appendix I.
NOTE: Drains should have liquid seals where appropriate to prevent the spread of fire through a drainage system.
- (f) A tank or compound used for the retention of spillage, with or without water, shall be constructed and located in a similar manner to the tanks and compounds used for storage. Such a compound shall comply with Clause 5.8.3(i).

NOTE: Several compounds may be drained into a single retention compound.

5.8.7 Management of fire water

Consideration in the design of the site shall be given to containment of fire water resulting from the management of a site emergency.

NOTE: The design should be such that from a typical spill and fire scenario the management of contaminated fire water can be retained within the site to enable the proper safe clean-up of this effluent.

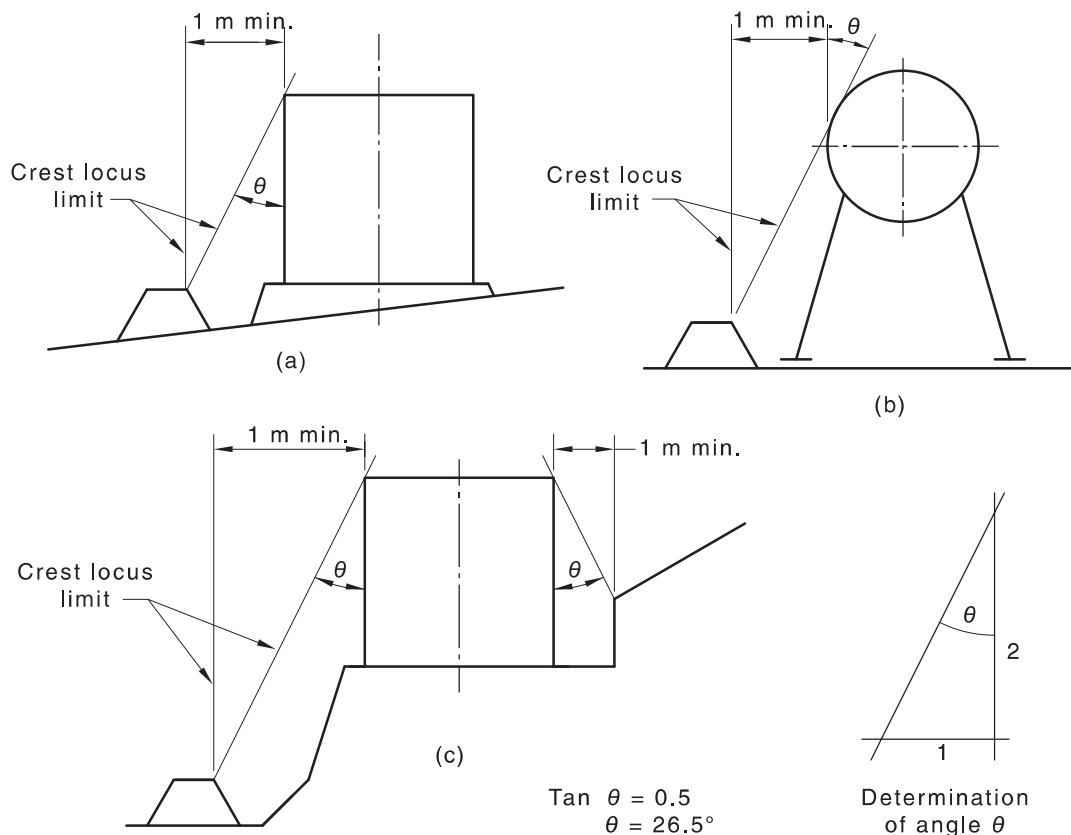

FIGURE 5.2 BUND LOCATION LIMITS

5.9 REQUIREMENTS FOR ABOVE-GROUND TANKS WITH INTEGRAL SECONDARY CONTAINMENT

5.9.1 General

A tank complying with this Clause (5.9) shall be one of the following:

- (a) A double-walled tank.
- (b) A tank having secondary containment and an external, fire-rated covering.
- (c) A tank with an attached or integrated spillage compound.

5.9.2 Requirements for all tanks having integral secondary containment

The following requirements apply to tanks with integral secondary containment:

- (a) The tank shall not be used for the storage of PG I flammable liquids.
- (b) The capacity of the tank shall not exceed—
 - (i) 55 000 L for PG II liquids;
 - (ii) 110 000 L for PG III liquids; or
 - (iii) 110 000 L for combustible liquids.

NOTE: For mine sites regulated by state, territory, or commonwealth legislation, a maximum of 200 000 L may be used.

- (c) The primary (inner) tank shall be constructed to AS 1692 or equivalent Standard.
- (d) The secondary containment shall be adequately designed and constructed, to contain the entire contents of the primary tank.
- (e) Means shall be provided to establish and monitor the integrity of the primary tank.
- (f) The tank shall be installed in accordance with Clause 5.11 or 5.12.6 as appropriate.

- (g) Where flammable liquid or vapour could escape from the interstitial space of a tank, the tank shall be separated by at least 3 m from any ignition source, including vehicles being refuelled.
- (h) Spacing between adjacent tanks shall be at least 600 mm.
- (i) The tank shall be protected from damage caused by an impact.
- (j) Means shall be provided to prevent release of liquid by siphon flow from the tank.
- (k) The tank shall be fitted with a means of determining the level of its contents. Such means shall be available to the delivery operator.
- (l) All piping connections to the tank shall be above the normal maximum fill level.
- (m) Tanks shall not be manifolded unless provisions are made to prevent their being overfilled.
- (n) Overfill protection shall be provided by a suitable alarm with the flow of liquid being stopped, before the tank overflows.

If the tank is designed to contain overflow, such an alarm is the minimum provision necessary to achieve this objective. If the overflow is to be discharged outside the secondary containment, an automatic shut-off shall be provided. These provisions shall not restrict or interfere with the proper functioning of the normal vent or the emergency vent.

- (o) Each fill point shall be provided with spill containment having a minimum capacity of 15 L per fill point. Such a device shall be fitted to a tank in order to catch and contain any minor spill during product delivery to the tank.
- (p) Where a tank having multiple compartments is installed, the separation distance to protected places shall be based on the aggregate volume of the compartments and the lowest flash point of the liquid in any tank compartment.
- (q) Venting shall comply with Clause 5.4. Venting of compartments of a multiple-compartment tank shall be based on the lowest flash point product in any of the compartments.
- (r) Where the interstitial space is enclosed, it shall be provided with venting in accordance with this Standard or with a UL approved method.
- (s) Means shall be provided to physically test the correct functioning of any internal valve without the need to remove the valve.

5.9.3 Additional requirements for double-walled tanks

The following requirements apply in addition to those in Clause 5.9.2 above:

- (a) Primary and secondary containment shall be wholly constructed of steel and shall be designed in accordance with AS 1692 or equivalent Standard.
- (b) Separation distances as given in Clause 5.7 shall apply.

5.9.4 Additional requirements for tanks with external fire-rated covering

NOTE: Fire-rated tanks include 'vaulted' tanks which comply with UL 2085 or are approved by Underwriters Laboratories (UL) or Factory Mutual (FM) to the equivalent US fire rating.

The following requirements apply to tanks having an external, fire-rated covering on both the tank and any supports:

- (a) The secondary containment shall have an FRL of 240/240/240.
- (b) Emergency venting for the interstitial space in this tank system may be provided by a weak seam incorporated into the tank's external cover. In such a system, this seam shall fail preferentially if the pressure within the interstitial space builds up excessively, without compromising the integrity of the secondary containment.

- (c) Tanks having an FRL of 240/240/240 shall be regarded as complying with the requirements for tanks in chambers (see Clauses 5.13.1 and 5.13.2).
- (d) Where the tank's secondary containment has an FRL of at least 240/240/240 or complies with UL 2085, the following separation distances shall apply:
 - (i) To on-site and off-site protected places, the distances given in Clause 5.7 may be halved.
 - (ii) To boundaries and public places 2 m.
 - (iii) To any security fence 1 m.
 - (iv) To a dispenser nil.

NOTE: A dispenser may be mounted on a tank, provided it is suitable for use in the hazardous area around the tank.

5.9.5 Additional requirements for tanks with integrated spillage compounds

The following requirements apply in addition to those in Clause 5.9.2:

- (a) The design of the external secondary containment shall comply with Clause 5.8.3 except that the 1 m separation distance given in Figure 5.2 does not apply. However, provision shall be made for inspection of the tank's outer surface.
- (b) The separation distances given in Clause 5.7 shall apply.

5.10 REQUIREMENTS FOR TANK CONTAINERS (ISO TANKS, PORTABLE TANKS) INCLUDING IBCs WHEN USED AS STATIC STORAGE TANKS

Tank containers and IBCs complying with the ADG Code may be used as static storage tanks. As such they are exempt from the provisions of Clause 5.2.1.

NOTE: The UN *Recommendations on the Transport of Dangerous Goods—Model Regulations* refers to these tanks as 'portable tanks' or IBCs.

Where flammable or combustible liquids are to be stored in tank containers or IBCs, other than when such containers are used as delivery tanks or in transit storage, the following requirements apply:

- (a) All of the requirements of this Section (Section 5) shall apply with the exception of Clause 5.2.1.
- (b) Tank containers or IBCs shall not be stacked.
- (c) Storage configurations shall be maintained to ensure venting from relief vents is to free space.

NOTE: This safety control is to guard against the potential for flame impingement and jet fire on the ISO tank or any other ISO tank through the ignition of vapours.
- (d) Tank containers or IBCs shall be separated from each other so as not to impede or obstruct any necessary firefighting operations.
- (e) IBCs used for flammable liquids shall comply with the ADG Code. This includes compatibility of the specific liquid with the IBC material and the designated life span for plastics and composite IBCs.

5.11 INSTALLATION METHODS FOR ABOVE-GROUND TANKS

5.11.1 Foundations

An above-ground storage tank shall rest on a foundation which is adequate to support, without unacceptable or uneven settling, the following loads and forces:

- (a) The direct load imposed by the tank when full of either water or product, whichever is the more dense.

- (b) Any possible overturning forces, and in particular those due to wind when the tank is empty.
- (c) Any uplift or other distorting forces such as may occur in a tank under pressure.

Any attachment between the tank and its supporting structure or foundation shall be adequate to withstand any such forces.

NOTE: Because of the wide variety of surface, subsurface, and climatic conditions, it is obviously not possible to establish design data to cover all such situations. The allowable soil loading requires a decision for each individual case, having regard to the permissible settlement (refer to AS 1726).

5.11.2 Supporting structures

Any supporting structure between the foundation and the tank shall comply with the following requirements:

- (a) Any supporting structure, or ancillary structure used to provide rigidity, shall be made wholly of non-combustible material.
- (b) Any metallic support that is more than 1 m high and supports a tank having a capacity greater than 2500 L of PG I and PG II liquids, or 5000 L of PG III liquid, or 10 000 L of combustible liquid, shall be protected by material having an FRL of at least 120/120/120.
- (c) The structure shall be designed according to the requirements of the Australian Standard applicable to the particular construction (refer to AS 4100 for steel and AS 3600 for concrete).
- (d) The design shall take account of the total mass of the tank when full of either water or product, whichever is the greater, any wind loading, any possible uplift loading on restraining connections, and any likely seismic loading (refer to AS 1170.4).

Any such anchorage shall be designed to overcome the maximum anticipated buoyancy force.

5.11.3 Tank bearing area

The method of support of a tank shall avoid excessive concentration of loads on the supporting portion of the tank shell. Legs, cradles or similar methods of support shall be attached in a manner that will prevent possible trapping of moisture and corrosion of the tank shell.

5.11.4 Tanks in areas subject to flooding

A tank located in a flood-prone area shall be anchored to prevent floating.

5.12 INSTALLATION METHODS FOR UNDERGROUND TANKS

5.12.1 Method of installation

Any tank with more than 50% of its height buried below the surrounding ground gradient and mounded without any surrounding pit or chamber shall be considered an underground tank and shall be installed in accordance with AS 4897 and the following requirements:

- (a) The tank shall be set on and be surrounded with at least 150 mm of non-corrosive inert material such as clean sand well-tamped into place.
- (b) The tank shall be covered with sand or earth to a depth of at least 600 mm or, alternatively, the cover shall consist of 300 mm of sand superimposed with reinforced concrete at least 150 mm thick. Any covering shall provide adequate support.
- (c) The tank shall be securely anchored where necessary to prevent floating. Any such anchorage shall be designed to overcome the maximum anticipated buoyancy force.

- (d) A tank within a building shall be wholly below the lowest floor level of the building, and shall have a concrete covering.
- (e) Glass reinforced plastic tanks shall be installed in accordance with the manufacturer's instructions.

NOTE: Tanks that are installed with part of the shell above ground gradient and with the shell exposed to atmosphere are not recommended because of corrosion control problems.

5.12.2 Access pits

Where a pit is provided for access to fittings or entry/exit points, it shall be lined to restrain the surrounding earth fill, the lid shall be of adequate strength for any normal traffic load, and the closure shall be designed to minimize ingress of rain-water.

5.12.3 Separation between tanks

The distance between any two underground tanks shall be at least 150 mm.

5.12.4 Proximity to property boundaries

An underground tank shall be protected from potential damage arising from adjacent properties by at least 2 m of boundary separation.

5.12.5 Proximity to foundations

An underground tank shall be located, with respect to existing building foundations and supports, so that the building loads cannot be transmitted to the tank.

5.12.6 Secondary containment

Where there is risk of leakage into a building, a tank shall be a double-walled tank buried in sand, or a single-wall tank installed in a chamber complying with the appropriate requirements of Clause 5.13 or other means of providing equivalent integrity.

5.12.7 Corrosion protection

Any buried tank, its anchorage and associated piping shall be protected from corrosion by one or more of the following methods:

- (a) Protective coatings or wrappings.
- (b) Cathodic protection (refer to AS 2832.1 and AS 2832.2).
- (c) Corrosion-resistant construction materials, e.g. FRP.

Consideration shall be given to the corrosion history of the area in the selection of the type of protection to be employed.

5.13 INSTALLATION METHODS FOR TANKS IN TANK CHAMBERS

5.13.1 Above-ground tank chambers

Any tank chamber that is on or partly below the lowest floor level shall be constructed in accordance with the following requirements:

- (a) The walls shall have an FRL of 240/240/240.
- (b) The roof shall be of reinforced concrete at least 150 mm thick.
NOTE: The roof may have a removable section or sections for access or maintenance.
- (c) Where a tank chamber is subject to superimposed loads, the thickness of the roof or walls, or both, shall be increased appropriately.
- (d) The floor shall be of masonry or reinforced concrete, or of material of equivalent strength, excluding earth and asphalt.
- (e) There shall be a clear space of at least 450 mm between any tank and any wall or roof of the chamber, or any other tank in the chamber.

- (f) Any doorway or other access opening in any wall shall be protected by a fire door or cover having an FRL of at least $-/120/30$. Such a door or cover shall be designed to normally be closed.
- (g) The sill of any doorway shall be raised to provide a liquid-tight compound capable of sustaining the hydrostatic load and having a net capacity at least that of the largest tank.
- (h) The tank chamber shall not have an automatic pump-out system.
NOTE: If spills could accumulate in the tank chamber, a manually operated low-point sump or pump-away facility should be installed.

5.13.2 Underground tank chambers

Any tank chamber that is wholly underground shall be constructed in accordance with the following requirements:

- (a) The walls and floor of the chamber shall be of reinforced concrete at least 150 mm thick and of such quality as to prevent any leakage out of or into the chamber.
- (b) The roof or lid shall be of reinforced concrete of the thickness necessary to support itself and any superimposed loads, but at least 150 mm.
- (c) Access shall be provided by means of a removable roof or lid, hatch, or access pit. Any cover shall have an FRL of at least 120/120/120.
- (d) There shall be a clear space of at least 450 mm between any tank and any wall or roof of the chamber, or any other tank in the chamber.

5.13.3 Backfilled chambers

Any backfilled chamber shall comply with the relevant requirements of Clause 5.13.1 or Clause 5.13.2, with the following exceptions or additions:

- (a) The distance from any tank to a side or top of the chamber shall be at least 150 mm or 300 mm respectively.
- (b) The distance between any two tanks in the one tank chamber shall be at least 150 mm.
- (c) A steel tank shall be set on a bed of sand at least 150 mm thick and, subject to Clause 5.11.2, all other spaces shall be filled with sand well-tamped into place.
- (d) Filling sand shall be water-washed and free from soil, rocks, gravel or ashes and other harmful matter, and shall have a minimum resistivity of 100 Ωm .
- (e) Any access pit shall comply with Clause 5.12.2.

5.14 SERVICE TANKS

5.14.1 Use of service tanks

A service tank shall be interposed between a storage tank and a burner, engine, or other fuel-consuming equipment in the following circumstances:

- (a) When the storage tank is higher than the consuming equipment.
- (b) When the supply pressure that the consuming equipment can tolerate might otherwise be exceeded.
- (c) When for any other reason it is necessary to provide a limited storage or pressure-controlling facility close to the consuming equipment.

The service tank shall be located close to the consuming device.

5.14.2 Service tank higher than storage tank

Where liquid is pumped from a storage tank to a service tank at a higher level (irrespective of any level control device which is fitted) an overflow pipe to the storage tank shall be provided. The overflow pipe shall have sufficient capacity to return the full capacity of the pump to the storage tank without spillage.

5.14.3 Storage tank higher than appliance

The service tank shall be—

- (a) close to the consuming device;
- (b) located outdoors if filled by gravity;
- (c) provided with at least two independent overflow shut-off devices arranged so that each will continue to function to prevent overflowing in the event of failure of the other; and
- (d) provided with a means of handling liquid overflow and tank over-pressure in the event that the shut-off provisions fail to operate.

5.14.4 Return systems

Where a return system is installed, the following requirements shall apply as appropriate:

- (a) Gravity return systems shall incorporate at least one overflow shut-off device to prevent the overflowing of the service tank.
- (b) Other return systems shall incorporate at least two independent overflow shut-off devices, arranged such that each will continue to function to prevent an overflow in the event of failure of the other device.

5.14.5 Service tanks indoors

Any service tank located indoors shall be installed in accordance with Clause 5.6 in addition to the requirements of this Clause (5.14).

SECTION 6 SYSTEMS FOR PIPING, VALVES, PUMPS AND TANK HEATING

6.1 GENERAL DESIGN AND CONSTRUCTION

6.1.1 Design suitability

The design, fabrication, assembly, testing and inspection of piping that is to contain flammable or combustible liquids shall be suitable for the expected working pressures, temperatures, and structural stresses. AS 4041 shall also be consulted.

AS 4897 shall be consulted when designing, installing and operating underground petroleum storage systems.

6.1.2 Material suitability

Any material used in the construction or installation of piping shall be suitable for the conditions of use (see also Clause 5.2.4). The following requirements apply:

- (a) The material shall be compatible with the particular liquid or any other component with which it may be in contact.
- (b) The material shall be resistant to any heat to which it may normally be exposed.
- (c) Where exposed to corrosion, from within or without, the material shall be sufficiently resistant to ensure a life span at least equal to other parts of the installation or to achieve its design life.

NOTE: Copper is not a preferred material for product lines and its use is to be discouraged for the following reasons:

- (a) It is mechanically weaker, and has a lower melting point than other materials (e.g. steel).
- (b) The jointing methods used for copper pipe are less robust than other systems (e.g. flanges, welds).
- (c) Given the wide range of flammable and combustible liquids, chemical reaction between the liquid and the copper pipe may be more likely.
- (d) Vibration could cause copper to harden over time.
- (e) Copper could catalyse the decomposition of some fuels.

6.2 PIPING

6.2.1 Design and construction

The following general design considerations shall be taken into account when designing or installing any piping:

- (a) Access for operating, testing, maintenance, replacement or drainage.
- (b) Support and fixing.
- (c) Exposure to mechanical damage.
- (d) Protection against corrosion wherever necessary, particularly for piping that is outdoors, or underground, or underwater, or which passes through or is embedded in any material likely to induce corrosion.
- (e) Suitability for the liquids to be piped, and possible change of such liquids.
- (f) Integration with any cathodic protection system.
- (g) Any need to relieve excess pressure between valved-off sections of pipe in liquid service.
- (h) Expansion or contraction of the piping.

- (i) Drainage for any trench in which pipes are laid.
- (j) Protection for any buried piping from superimposed loads or ground settlement.
- (k) Electrical bonding and earthing (refer to AS/NZS 1020 and IEC 60079-32-2).
- (l) Where piping is encased in concrete, the need to guard against corrosion and to provide for expansion.
- (m) Painting or marking of piping, to permit ready identification of its contents (refer to AS 1345).
- (n) Access to, and operation of, valves and other control devices, including ergonomic considerations.
- (o) Fire resistance, where piping could be exposed to fire.

6.2.2 Joints

Joints in piping shall be suitable for the operating pressures, temperatures, materials, and other conditions of use. Particular attention shall be paid to the joint's vulnerability to failure in the event of fire and susceptibility to corrosion, particularly if it is buried or submerged.

Joint types that are suitable are—

- (a) threaded joints conforming with AS 1722; and
- (b) flanged joints conforming with AS 2129 or ASME/ANSI B16.5, Class 150.

NOTES:

- 1 Mechanical grooved couplings tested to API Std 607 should only be used to accommodate misalignment or movement.
- 2 AS 4041 provides requirements for joints in pressure piping.
- 3 For small diameter piping, joints should be of a metal-to-metal compression type.

Any joint in copper pipework shall be made only with a flare compression fitting, or with a capillary fitting using a brazing metal with a melting point of at least 540°C, or by a spigotted joint formed from the pipe itself, and brazed as above. Flare fittings having mismatching cone angles shall not be used.

6.2.3 Flexible tubing

This Clause (6.2.3) applies to the connection of the fuel dispenser to the supply piping, but does not apply to the internal piping of the fuel dispenser.

Flexible tubing, piping or hose may be used, provided that the principles of Clauses 6.1 and 6.2.1 are met. Such tubing shall meet any necessary requirements with regard to compression, elongation, and angles of horizontal and vertical displacement.

A hose assembly shall be designed or shall have been tested to withstand at least 1.5 times the maximum allowable operating pressure, regardless of whether it is under pump pressure or at zero flow, and including dead-heading and system back-pressure.

6.2.4 Transfer hose

A hose and hose assembly for distribution of petroleum products (except LP Gas) shall comply with AS 2683.

NOTE: Products other than petroleum may require specific hose materials or couplings, because of compatibility of materials, additional hazards or the like.

6.2.5 Vapour recovery piping

Any vapour recovery piping system for tank vehicle filling installations shall be designed so that when all pump-supplied tank vehicle filling provisions served by that vapour recovery system are in use simultaneously, the back-pressure on each tank vehicle does not exceed its normal operating pressure.

6.3 VALVES

6.3.1 System requirements

Sufficient valves shall be provided to permit proper operation of the system and to protect the installation. The following requirements apply:

- (a) A manually-operated tank or liquid outlet valve shall be located as close as possible to the shell of an above-ground tank.
- (b) A non-return valve shall be located in each tank-filling pipe close to the filling connection unless the levels of the filling connection, the downstream filling pipe, and the tank are such that backflow cannot occur when the filling hose has been disconnected. Where an anti-siphon opening is made in the filling pipe above the maximum liquid level in the tank, a non-return valve is not required.

6.3.2 Emergency shut-off provisions

Provision shall be made to shut off the flow of liquid quickly in an emergency—

- (a) from the storage tank and service tank to a consuming device; and
- (b) to a tank vehicle fill point.

Any manually operated valve or the actuating device for a remotely operated valve shall be located in a convenient and safe location and conspicuously marked with the words EMERGENCY LIQUID SHUT-OFF or EMERGENCY STOP.

6.3.3 Valve selection

Any valve used for a flammable or combustible liquid shall comply with the following requirements:

- (a) For any valve that can be operated or closed by manual action, the distinction between the open and shut positions shall be obvious.
- (b) Any hand-operated valve having a handwheel, cross, tee or similar symmetrical handle, shall close by clockwise rotation, when viewed from the end of the spindle of the actuating device. A hand-lever operated valve shall be installed so that the lever is at right angles to the pipe when closed, and so that gravitational forces on the handle will not act in the direction of opening except where the valve is designed to fail-safe. The direction of closing shall be clearly marked.
- (c) The use of detachable handles for valves shall be avoided unless essential for security, for procedures, or for sequences. Any such handle shall not be removable unless the valve is at a safe setting and so indicated.
- (d) It is preferable that the valve type permits gland repacking to be achieved without having to remove the valve from its installed position.
- (e) Any valve whose failure in the event of fire could create a hazard shall be of either steel or a suitable grade of spheroidal graphite iron. The valve handle shall be of metal not inferior to the valve body in fire resistance.
- (f) Cast steel fire-safe valves shall be provided—
 - (i) where any tank valve is below the liquid level of a tank of Categories 4, 5 or 6 containing flammable or combustible liquid; or

- (ii) where located in the transfer piping between marine tanker berths and storage tanks.

NOTE: If a cast steel valve incorporates no soft seals or other parts that could be affected by a fire, it may be considered to be 'fire-safe' and does not usually require a fire type test, (e.g. gate valves to API Std 600).

6.4 PUMPS

6.4.1 Pressure and temperature control

Where the discharge pipe of a pump can be shut off, provision shall be made to prevent the build-up of pressure or temperature in excess of the design capability of the pump and piping. The design of the system shall take into account the following:

- (a) A hydraulic relief valve shall not normally be provided with an isolating valve.

Any such isolation valves, if installed, shall be arranged to be secured in the open position.

NOTES:

- 1 Pump bypasses may be installed to prevent local overheating. Isolation valves to serve hydraulic relief valves or pump bypasses are not recommended.
- 2 Discharge from a hydraulic relief valve should be returned to the supplying storage tank or returned to the pump inlet provided that the heat generated by such recirculation is within design limits.

- (b) The range of adjustment of any hydraulic relief valve shall be restricted to prevent excess pressure, or an excess-pressure relief valve shall be fitted.

6.4.2 Emergency shut-off

An emergency shut-off device shall be provided on each pump. The shut-off device shall be readily accessible and its purpose clearly identified.

6.4.3 Pump drive

Clauses 3.4 and 3.5 shall apply to motors and engines for driving pumps.

6.5 HEATING OF LIQUIDS

6.5.1 Access for service

Critical components of the control system shall be removable without the need to drain any tank. The design, fixing and sealing of any insulation or lagging on pipes and tanks shall be such as to avoid the retention of moisture and to allow the removal of the insulation for inspection and maintenance purposes.

6.5.2 Condensate

Condensate from a steam heater that might be contaminated with flammable or combustible liquid shall not be returned to a boiler feed without treatment to ensure that it is suitable as feed water.

6.5.3 Heating of pipes

Where heating is provided by means of heat-tracing, the supply shall be thermostatically controlled and shall comply with AS/NZS 3000.

6.5.4 Heater controls

Where heating elements could become exposed above the liquid level because of normal operating level fluctuations, and the temperature of the heating medium is within 6°C below the flash point of the liquid (see Clause 6.5.5), sufficient valves or control systems shall be provided to isolate such exposed heating elements.

6.5.5 Temperature limits

The maximum temperature to which any portion of the liquid may be heated shall be below the temperature at which cracking, decomposition, or ignition could occur.

NOTES:

- 1 Where water could be present, the heating should be controlled to prevent sudden eruptive boiling.
- 2 See Appendix J for combustion characteristics of various flammable liquids.

6.5.6 Temperature monitoring

The energy input shall be controlled to prevent boiling, steam eruption or deterioration of the liquid. An excess temperature control and alarm shall be fitted.

Where the temperature rise is slow and not liable to cause deterioration of the liquid, a management system may be used for monitoring if a satisfactory, documented risk assessment has been conducted.

SECTION 7 FUEL DISPENSING

7.1 SCOPE OF SECTION

This Section applies to sites at which flammable or combustible liquids are dispensed into the fuel tanks of vehicles, boats or other containers. It covers both private and retail installations, but does not apply to the bunkering of large vessels or the refuelling of aircraft.

NOTE: The principles given in this Section may be applied to the refuelling of light aircraft.

7.2 GENERAL REQUIREMENTS

7.2.1 Storage method

Any flammable or combustible liquid in quantities exceeding those dealt with in Section 2 shall be kept in package stores or tanks in accordance with Sections 3, 4 and 5 as appropriate.

7.2.2 High-level tanks

Any tank which is so situated as to produce a gravity head at the dispenser shall be equipped with a fail-safe solenoid valve or other equally effective device which shuts off the supply at the tank outlet except when the dispenser is in use. Where the tank is either Category 1 or 2 and there is no metering dispenser, a manual shut-off valve shall be provided at the tank.

7.2.3 Gaseous fuels

Where gaseous fuels for vehicles are stored, handled and dispensed on the premises, the following provisions shall be observed:

- (a) AS/NZS 1596 for LP Gas.
- (b) AS 3961 for LNG.
- (c) AS 5092 for CNG.

7.2.4 Emergency power cut-off

A clearly identified switch or circuit-breaker which will enable the power to be shut off to all dispensing units shall be provided at a location remote from any dispensing unit and easily accessible in an emergency.

NOTE: Consideration should be given to incorporating a single emergency stop that would shut off all fuel dispensing.

7.2.5 Signs

A prominent sign on or near the dispenser shall be marked in letters at least 50 mm high as follows:

STOP ENGINE—NO SMOKING

The international symbol for 'smoking prohibited' may be used in lieu of the words 'no smoking'. The words 'no flames, pilot lights or mobile phones' may also be added.

7.2.6 Hazardous areas

The hazardous areas for dispensers as defined in AS/NZS 60079.10.1 differentiate between petrol and LP Gas so care should be taken to consider the interrelation of the two areas where both fuels are being dispensed.

7.3 DISPENSERS

7.3.1 General

The design, construction and testing of fuel dispensing equipment shall be in accordance with AS/NZS 2229.

7.3.2 Location

A dispenser shall be located in accordance with the following requirements:

- (a) The location or protection shall be such as to minimize the possibility of damage from vehicles, boats or the like.

NOTE: In design, consideration should be given to limit/reduce the speed of vehicles entering the area by controls such as signage, speed reduction forecourt humps or other traffic management methods.

- (b) Any dispenser serving road vehicles with flammable liquids shall be so located that any vehicle is entirely on the premises while being fuelled, and no part of the dispenser housing is less than 4 m from the boundary. The location shall permit free air movement for the dispersal of vapours from refuelling.

NOTE: This distance may be measured around a vapour barrier.

- (c) Any dispenser for flammable liquid shall be located to comply with the following minimum separation distances:

- (i) From any above-ground flammable liquid storage or handling facility other than a dispenser—8 m.

- (ii) From any point where the bulk tank of a road tank vehicle or rail tank vehicle is being filled—15 m.

- (d) Notwithstanding Clause 7.3.2(b), where a dispenser is located inside a building, it shall comply with the following:

- (i) The dispenser shall be located within 1.5 m of the vehicle entrance.

- (ii) The dispenser shall be used only for the supply of vehicle fuel to a vehicle or into a container that is located on the carriageway used by vehicles entering the building by that entrance.

- (iii) The nozzle shall comply with Clause 7.4.

- (iv) The carriageway and area within 1.5 m of the dispenser shall be graded so that any fuel spilled during any dispensing will flow directly out from and clear of the building. The spill shall be contained on the premises.

- (e) Any fixed, portable or mobile ignition source shall not be present within hazardous areas for a dispenser as defined in AS/NZS 60079.10.1, except for a vehicle entering or leaving the dispensing area and personal equipment (e.g. hearing aids and basic electronic watches).

7.3.3 Drainage

Any area on which a vehicle can stand while being fuelled shall be so graded that spilled liquid will flow away from any building, and will not flow off the site. Any interceptor or oil separator shall be readily accessible for inspection and cleaning. Such interceptor or separator shall be able to contain a minimum of 50 L of hydrocarbon spill.

7.3.4 Dispenser bypass

Where a dispenser is provided with a bypass return pipe, it shall be arranged to return the liquid to the tank from which it is being drawn.

7.3.5 Remote pumping systems

Where a flammable liquid is supplied to a dispensing installation by means of a pump that is not located at the dispenser, the following requirements shall apply:

- (a) Unless the pump is submerged in a tank, it shall be located above ground in the open, suitably weather-protected, and not less than 2 m from any boundary of the premises or on-site protected place.
- (b) The pump control system shall permit the dispenser to operate only when a dispensing nozzle has been removed from its hanging bracket, and shall stop the pump after all of the nozzles supplied from that pump have been returned to their normal non-dispensing positions.
- (c) A valve incorporating a pipe-shear provision and automatic flow shut-off shall be installed at each pressurized dispenser inlet. This valve shall be securely attached to the ground. The shear provision shall be below or as near as possible to ground level.
- (d) All pipelines subject to pump pressure shall be hydrostatically tested to not less than twice the maximum shut off pressure of the pump unit prior to commissioning.

Pipeline integrity and leakage shall be monitored by—

- (i) hydrostatic testing at intervals of not more than two years; or
- (ii) leak detection equipment and inventory control; or
- (iii) other systems giving equivalent results.

NOTE: AS 4897 provides guidelines.

- (e) Any leak in a pressurized piping system shall be able to be readily detected.

7.3.6 Unsupervised self-service systems

Any dispenser that is operated by a customer by means of currency or other means of payment, e.g. credit card, shall comply with the requirements of this Clause (7.3.6) as appropriate, and the following:

- (a) The dispenser hose shall be shorter than the distance from the dispenser to the nearest building or to the nearest boundary of an adjacent property.
- (b) The area around the dispenser and the payment unit shall be lit in accordance with Clause 3.6 at all times during which the unit is available for service.
- (c) The installation shall include an emergency shut-down device having the following functions or features:
 - (i) When activated, the emergency device shall shut off the dispenser pump and transmit an alarm to a person or organization capable of responding.
NOTE: It may also be used to release access to fire extinguishers (see Clause 11.9).
 - (ii) It shall be readily accessible, and shall be integral with or adjacent to the currency or card receptor.
 - (iii) It shall be protected from vandalism or unwarranted operation by a break-glass screen or equivalent.
 - (iv) A notice shall be displayed, giving instructions on how to operate the device in the event of a major spill or fire.

7.3.7 Supervised self-service systems

Any installation where a dispenser is operated by a customer under the observation of a central supervisor or attendant shall incorporate the following features:

- (a) A control station or console, which shall be located within 40 m of each of the units, so that each unit's operation is visible to the attendant by direct vision or by means of mirrors, or other suitable means.
- (b) A control console switch that can cut off the operation of all dispensers.
- (c) A telephone adjacent to the control console. A list of emergency telephone numbers, including the fire brigade, ambulance services and other emergency responders shall be prominently displayed near the telephone.

Dispensers shall not be operable unless an attendant is on duty at the control console, or the installation has been switched over to operate as an unsupervised self-service system. In the latter case Clause 7.3.6 shall apply.

7.4 DELIVERY HOSES AND NOZZLES

7.4.1 Nozzle design

Where fuel to the dispenser's delivery nozzle is supplied by a pumping system, the following features shall be incorporated:

- (a) The nozzle shall incorporate a device which automatically shuts off fuel flow to that nozzle when the level of the liquid in the receiving vessel reaches the end of the nozzle.
- (b) The nozzle shall be designed so that fuel flow to that nozzle is shut off, and remains shut off if the nozzle is dropped onto a non-resilient surface from a height of 250 mm or greater.
- (c) The nozzle shall incorporate a safety device (safety cut-out attitude valve) so designed that the fuel flow to that nozzle is shut off and remains shut off if the nozzle spout is tilted above horizontal from its normal operating position.
- (d) The nozzle on any dispenser which has a value or quantity preset facility incorporated into its operation shall not be provided with a latching device.

7.4.2 Customer-operated nozzles

The delivery nozzles for flammable liquids dispenser that are intended to be operated by a customer shall not have a latching device. No item, e.g. fuel cap, keys or any other device, shall be used to hold open a customer-operated nozzle.

7.4.3 Conductivity

The delivery hose and nozzle assembly shall be capable of dissipating any static electricity charge generated during filling.

7.4.4 Hose assembly

The dispensing hose assembly shall comply with AS 2683.

7.5 MARINE DISPENSERS

7.5.1 Application

Installations for refuelling boats shall comply with the requirements of this Section (7) where relevant, unless varied by Clauses 7.5.2, 7.5.3, 7.5.4, and 7.5.5 below.

7.5.2 Pipework

Pipework supplying an off-shore marine dispenser shall be provided with a readily-accessible emergency isolation valve at or near the shoreline. It shall be clearly marked,

EMERGENCY STOP VALVE

Pipework shall have secondary containment in the form of double-walled piping with an interstitial space. All piping shall be pressure tested annually to 1.5 times the maximum working pressure. The integrity of the secondary containment shall be checked and maintained.

7.5.3 Location

Any dispenser serving boats shall be located so as not to impede entry to or exit from the boat being fuelled.

7.5.4 Nozzle

Any hand-held dispensing nozzle shall comply with Clause 7.4.1 and shall not be provided with a latching device.

7.5.5 Instructions

The instructions listed in Table 7.1 shall be displayed in a prominent location where flammable liquid is dispensed.

TABLE 7.1
MARINE REFUELLING INSTRUCTIONS

Before refuelling	During refuelling	After refuelling
Check that dispensing point is equipped with fire appliances Put all passengers ashore and clear of refuelling stations Take any portable tank to be filled to a place safely clear of the boat Prohibit smoking and striking of any sparks in the area Turn off pilot lights to gas refrigerators Cut off electric power at main switch Close all hatches and the like to prevent fumes entering the hull and lying in the bilges	Maintain contact between the hose nozzle and fixed pipe to prevent static sparks Avoid any spillage, either into the boat or onto water Carefully monitor filling rate to avoid overfilling	Thoroughly clean up all spillages Open all hatches and ventilate the boat If fuel has spilt, pump out bilges (manually) and leave boat wide open for at least 30 minutes. Do not pump any spilt fuel overboard When completely satisfied that the boat is free of fumes, start the engine before allowing passengers aboard

7.6 OPERATIONS

7.6.1 Records

Inventory records of liquids received, stored and dispensed, shall be maintained and reconciled. Where any discrepancy in records indicates possible leakage, the installation shall be checked and any leaks found shall be rectified.

7.6.2 Procedures

Operating procedures shall take into account the following:

- (a) The prevention of smoking or any other ignition sources within 3 m of any point where flammable liquid might be exposed, particularly when receiving or dispensing.
- (b) The need to switch off a vehicle's engine while refuelling.

- (c) Any possibility that vapour from a flammable liquid fill or vent pipe could reach an internal pilot flame on a campervan or caravan if the appliance vent has been badly located in relation to the filler (in such cases it is necessary to turn off the pilot before filling).
- (d) The prevention of overfilling and spillage when storage tanks are being replenished.
- (e) The maintenance of fill and dip caps in a liquid-tight condition.
- (f) The suitability of containers being filled at dispensers for use, i.e. container condition and material, the presence of an effective cap, correct labelling. Containers shall not be filled when inside a vehicle compartment (see also Clause 7.6.3).
- (g) Specific instructions that do not allow the filling of plastic containers that do not comply with AS/NZS 2906 or equivalent Standard.
- (h) Risks when cleaning parts with flammable liquid.
- (i) Procedures to be followed in the event of spillage, and particularly the spillage of flammable liquid on clothing.
- (j) Risks when draining fuel tanks, particularly over inspection pits.
- (k) Precautions for hot work on vehicle fuel tanks.
- (l) Safety of electrical equipment used in pits.
- (m) Floors shall not be washed with flammable liquid.
- (n) Emergency clean-up equipment shall be available in case of spillage.
- (o) Persons under the age of 15 years shall be prevented from operating fuel dispensers.
- (p) Precautions for working in confined spaces.
- (q) Training in the use of emergency equipment and maintenance of appropriate records.

7.6.3 Filling of containers with flammable liquids at dispensers

Flammable liquids shall not be filled from a service station's fuel dispenser into a container unless the capacity of the container is not greater than 25 L, and—

- (a) the container complies with AS/NZS 2906 or equivalent Standard, or is substantially leakproof, metal, and has a tight-fitting closure; or
- (b) the container is a suitable portable fuel tank for a boat.

NOTE: Suitable portable fuel tanks for boats may be filled in situ.

Any container shall be on the ground whilst being filled, and not in a car boot or the back of a utility vehicle.

7.6.4 Filling of containers with combustible liquids at dispensers

Any container shall be leakproof and have a tightly fitting closure.

SECTION 8 TANK VEHICLE LOADING FACILITIES

8.1 SCOPE OF SECTION

This Section provides general requirements for installations where tank vehicles are filled, as well as, specific filling instructions. The requirements of this Section are additional to those of the ADG Code.

8.2 GENERAL REQUIREMENTS

8.2.1 Transfers

Transfers to a tank vehicle shall not be achieved by pressurization unless the entire system has been designed for the pressure and a suitable gas is used.

8.2.2 Location of fill point

8.2.2.1 Separation from above-ground tanks

The point of connection to the tank vehicle shall be separated from any on-site above-ground tank by the minimum distances given in Table 5.3.

8.2.2.2 Separation from protected places

The following distances shall apply:

- (a) Where flammable liquids are loaded, a minimum separation distance of 15 m from the connection point.
- (b) Where flammable and combustible liquids are loaded, a minimum separation distance of 15 m from the connection point.
- (c) Where only combustible liquids are loaded, a minimum separation distance of 3 m from the connection point.

8.2.2.3 Separation from package stores

The following distances shall apply:

- (a) Where flammable liquids are loaded, a minimum separation distance of 8 m from the connection point.
- (b) Where flammable and combustible liquids are loaded, a minimum separation distance of 8 m from the connection point.
- (c) Where only combustible liquids are loaded, a minimum separation distance of 3 m from the connection point.

8.2.2.4 Separation from on-site protected places, ignition sources and security fences

The separation distance shall be that given in AS/NZS 60079.10.1 for hazardous areas.

At multi-tanker loading bays, vehicles other than those to be loaded shall not drive through a Zone 1 area.

8.2.3 Building requirements

Where the fill point is within a building, the building shall be open on at least three sides where flammable liquids are stored, or on two sides where C1 liquids are stored. The building shall be used solely for tanker loading.

NOTE: Any side of a building where the wall sheeting does not extend to within 2 m of the ground may be considered open for the purpose of this Clause (8.2.3).

8.2.4 Collision protection

A tank vehicle filling facility shall be protected against damage from vehicles and forklift trucks by a guard rail, traffic bollards or other physical barriers.

8.2.5 Vehicle access

The direction of entry of vehicles into a tank vehicle filling area shall be clearly marked.

The design of a tank vehicle loading facility shall be such that vehicles are positioned so that in an emergency, they can be driven or towed out without recourse to reversing (see also Clause 9.18.4).

8.2.6 Spillage control

8.2.6.1 General requirements

The tank vehicle filling area shall have a system for collecting any spilt liquid and draining it to a containment tank or compound. The following requirements apply:

- (a) The vehicle standing area shall be graded so that any spillage will drain away to dedicated tank or compound and not spread to other loading areas.
- (b) The surfaces of the system shall be impervious to any liquid that might be spilt.
NOTE: Concrete is a suitable material.
- (c) The tank or compound in which spillage is retained shall be constructed and located in a similar manner as that described in Clause 5.8.
- (d) A spill response kit shall be positioned within 15 m of the tank fill point.

Alternatively, a system based on a documented risk assessment and providing an equivalent level of protection may be used.

8.2.6.2 Capacity of spillage control system

The capacity of the spillage control system shall be the greater of—

- (a) the capacity of the largest compartment of any tank vehicle using the facility or 9000 L, whichever is less; or
- (b) the maximum volume of liquid that can be discharged from the two filling points having the greatest flow over 2 minutes.

The capacity shall be increased where necessary to provide for rain, clean-up or output from fire protection systems.

8.2.6.3 Drainage

Drainage of spilt liquid from the tank vehicle filling area shall be provided. One of the following methods shall be used:

- (a) Use of an isolating valve.
The isolating valve shall be kept closed at all times except when liquid is being drained.
NOTE: Drainage should be through a separator pit under controlled conditions, unless the system is designed to operate with the valve continuously open.
- (b) Drainage directly to a separator pit.
The pit shall be designed for the expected flow.
- (c) Drainage directly to a remote compound, tank or pump-out pit.
NOTE: Subsequent treatment should be through a separator pit.
- (d) A combination of the above.

Where an isolating valve is used, it shall be clearly marked with the words:

TANK VEHICLE FILLING AREA DRAIN VALVE—NORMALLY CLOSED

and shall be marked to indicate the open and closed positions.

Separator pits shall be capable of dealing with the flow rate from the drainage system, in accordance with regulatory requirements.

8.2.7 Flow rates

The flow velocity into the compartment of a tank vehicle shall be controlled to less than 1 m per second until a minimum level of 150 mm has been reached. Maximum flow velocity thereafter shall not exceed 7 m per second until filling is nearly completed, when the flow velocity shall again be reduced to minimize hydraulic shock when filling stops.

8.2.8 Emergency shut-down

Any transfer pump shall be provided with an emergency shut-down device located in a prominent position at least 10 m but not more than 30 m from any tank vehicle filling point. It shall be clearly marked EMERGENCY PUMP STOP.

8.2.9 Earthing and bonding

Static electricity shall be dissipated during tank vehicle filling, in accordance with AS/NZS 1020 or IEC 60079-32-2.

8.2.10 Bond wire connection

The bond between the vehicle tank being filled and the filling facility shall be made with a flexible sheathed cable meeting the requirements of AS/NZS 60079.14 for bond cables. It shall be securely attached to the filling facility at one end and provided with a robust spring clip, G clamp, plug and socket or equivalent at the other end.

NOTES:

- 1 The size of the flexible sheathed cable above is unrelated to its resistance but is necessary to provide a robust flexible connection suitable for field use.
- 2 A flexible cable used in a system to prevent overfilling of the tank vehicle and containing a dedicated bond wire connected by a special plug and socket is an acceptable alternative.
- 3 The sheathing on a bond cable should be resistant to the product.

8.2.11 Monitored cable connection

A monitored cable connection using a plug and socket may be either—

- (a) part of an integrated tanker overfill controls system; or
- (b) provided with visual indication of bond integrity.

8.3 TOP-FILLING INSTALLATIONS

8.3.1 Access to vehicle tank

A platform with an anti-slip surface and an elevated grating or walkway shall be provided for each tank vehicle position and shall be provided with fall protection. Any platform over 6 m long shall have a means of egress at each end.

If handrails are suspended from the roof structure, they shall be provided on the opposite side of the vehicle tank to the access platform.

NOTE: AS 1657 provides requirements and guidance on the design, construction and installation of platforms, walkways, stairways and ladders.

8.3.2 Open-hatch filling

An open-hatch filling facility shall comply with the following:

- (a) Flammable liquid transfer shall be through rigid piping extending to and in contact with the bottom of the vehicle tank compartment during the entire transfer operation. A hose shall not be used inside a vehicle compartment.
- (b) Where the liquid transfer operation is controlled by a pre-set measuring device, an overriding 'stop' mechanism shall be provided.
- (c) Where a liquid transfer operation involving flammable or C1 liquids is controlled manually, it shall incorporate a valve which is manually held open, closes upon release and cannot be locked or fixed open. Where such a valve is not of fire-safe construction and is used for loading flammable liquids, a fire-safe isolation valve shall be installed within 15 m of the fill point.

NOTES:

- 1 Where the products being transferred are viscous, e.g. bitumen, and there are operational problems in complying with Clause 8.3.2(a), the requirements of this Clause (Clause 8.3.2) need not apply. In such situations, operational safety should not be compromised.
- 2 A procedural alternative to Items (b) and (c), such as two-person filling, where one person controls the flow whilst the other is dedicated to fill monitoring, and both can intervene to stop the flow if necessary, may be used, but a physical means of control is preferred.

8.3.3 Tight-connection filling

Liquid transfer into a tank vehicle employing a fixed internal filling tube with leak-proof connections within the coaming area of the vehicle tank shall comply with the following:

- (a) Final connection of pipework to the vehicle tank shall be rigid metal piping or a flexible hose complying with AS 2683.
- (b) The requirements of Clause 8.3.2(b) and 8.3.2(c) shall apply.

8.4 BOTTOM-LOADING FACILITIES

8.4.1 System design

A bottom-loading facility shall incorporate the following:

- (a) A preset meter incorporating automatic slow-start and slow-finish controls.
NOTE: Aviation refuellers are excluded from this requirement.
- (b) A dry-break coupling between the loading arm or hose and the vehicle tank.
- (c) Automatic overfill protection for each vehicle tank compartment.
- (d) An integrated bond cable between the pipework in the filling facility and the vehicle tank.
- (e) Provision for vapour relief, accessible from ground level, which includes a means of safely discharging the vapours to atmosphere or to a vapour recovery system.
- (f) Interlocks to—
 - (i) prevent the tank vehicle from moving whilst hoses are connected;
 - (ii) prevent liquid transfer if the bond wire and vapour collecting hose are not properly connected; and
 - (iii) prevent the liquid transfer if any one of the overfill protection devices has been tripped.

NOTE: The above Clause is not intended to apply to bottom loading of bitumen, as the nature of the product makes such loading impractical. API RP 2023 provides guidance on the loading of bitumen.

8.4.2 Compliance with API Code

Where appropriate, a bottom-loading facility should comply with API RP 1004 where not otherwise dealt with in this Standard.

8.4.3 Design pressure

All components which are subject to pump shut-off pressure shall be designed to withstand a pressure not less than 1.5 times the maximum shut-off pressure of the transfer pump.

8.4.4 Flow rates

The liquid transfer into the vehicle tank shall be controlled within the limits specified in Clause 8.2.7, and shall reduce the flow rate towards the end of filling to minimize hydraulic shock.

8.4.5 Overfill protection

Means shall be provided to ensure the overfill protection devices are active and to prevent liquid transfer into any compartment under fault conditions. Any faults shall be indicated by a clear visible signal.

8.4.6 Internal valve and vent control

A pneumatic system for opening and closing the internal valves and vents of each compartment shall be interconnected with the tank vehicle braking system. This is to prevent the tank vehicle being driven or moved while the internal valves and vents are open, or while any liquid transfer hose is connected to the tank vehicle.

8.4.7 Data collection

A data collection device, which incorporates some or all of the control devices required by this Section, may be provided within the bottom-loading facility provided it complies with all relevant Standards.

8.4.8 Atmospheric venting

Where vapours are discharged to atmosphere during transfer, the discharge shall be in a vertical direction from a point at least 2 m above the highest point of the roof of the filling facility or, if not roofed, 8 m above the floor of the filling facility. The separation distances given in Clause 8.2.2.2(b) and 8.2.2.2(c) shall apply to the vent outlet. The vent shall be provided with flashback protection at its outer extremity.

SECTION 9 OPERATIONAL AND PERSONNEL SAFETY

9.1 SCOPE OF SECTION

This Section sets out requirements and recommendations on matters relating to operational and personnel safety. It applies to all storage other than minor storage, but the principles stated may be applied to achieve a greater measure of safety in such storage.

NOTE: Section 10 should also be consulted.

9.2 GENERAL PRECAUTIONS

9.2.1 Control of entry

In order to prevent unauthorized personnel from gaining access to the installation, a member of the occupier's staff should accompany those visitors, contractors' personnel and other persons whose duties require their entry into a restricted area. Where this cannot be done, such persons shall, before their entry into the restricted area, be given a written list of the hazards present and the appropriate precautions to be taken or undergo induction training. Any contractors working on-site shall be suitably trained (see Clause 9.10.3).

It is recognized that compliance with the above requirement is not possible where emergency services personnel have to enter unattended premises to attend an emergency. A safety information board is sufficient for such purposes.

Any restricted area shall be locked whenever it is unattended.

9.2.2 Clear access

The means of entry into and access from any area, room or building, in which flammable or combustible liquids are stored or handled shall be kept clear at all times.

At all times, access shall be available to—

- (a) firefighting equipment;
- (b) personal protective equipment;
- (c) clean-up materials and equipment; and
- (d) the place where the manifest is kept.

9.2.3 Vehicular access in restricted areas

The following requirements apply:

- (a) Vehicular access to, and movement within, a restricted area shall be controlled.
- (b) Vehicles shall be confined to a designated safe area unless they are suitable for use in hazardous areas.
- (c) Speed limits shall be imposed where appropriate, and shall be indicated by signs.
- (d) Vehicles shall be parked in designated parking places and comply with any operating and emergency procedures.

9.2.4 Vehicular access into a compound

Any vehicular access over a bund and into a tank's compound shall be kept barricaded and locked when not in use.

A notice bearing the words NO VEHICLE ACCESS WITHOUT WRITTEN PERMIT, in clearly legible red lettering, 100 mm high on a white background, shall be displayed at the access point.

9.2.5 Access by locomotives

A work permit shall be issued to control the entry of any locomotives into a hazardous area.

9.2.6 Lighting

The following requirements and recommendations apply to lighting that is provided:

- (a) During the hours of operation, sufficient lighting shall be provided in work areas so as to enable a person to easily read all markings on packages, signs, instruments and other necessary items. Interior lighting should be of at least the luminance specified in AS/NZS 1680.1.
- (b) Sufficient lighting shall be available on any of the installation's internal roads when personnel on the premises might use them.
- (c) Reference should be made to the appropriate part of AS/NZS 60079.10.1.

9.2.7 Control of ignition sources

9.2.7.1 Introduction of ignition sources

A work permit shall be obtained before introducing any active or potential ignition source into a restricted area.

Conditions for work permits are given in Clause 9.8.3.

9.2.7.2 Portable electrical equipment

Portable electrical devices shall not be taken into a hazardous area unless certified for use in such an area or authorized by a work permit.

NOTE: For guidance, refer to AS/NZS 60079.14.

This is to control ignition sources such as torches, rechargeable power tools, pagers, phones and cameras, but not low-energy devices such as hearing aids or completely enclosed objects such as battery-powered watches.

9.2.7.3 Smoking

Smoking or the carrying of matches or cigarette lighters shall be prohibited in any hazardous area as defined by AS/NZS 60079.10.1 and within any restricted area.

Within a restricted area, any specifically designated place where smoking is permitted shall be clearly identified by SMOKING PERMITTED signs.

9.2.7.4 Earthing and bonding

Static electricity shall be controlled in accordance with AS/NZS 1020. Lightning protection shall comply with the requirements of AS/NZS 1768. Earthing shall comply with AS/NZS 3000.

NOTES:

- 1 Bonding and earthing are often confused with each other.
- 2 Bonding connects all items where static electricity might build up. For example, a tank, pump, filling nozzle and receiving container could be connected with each other through pipes with bridged flanges, conducting transfer hoses and bonding wires and clips.
- 3 Earthing discharges dangerous currents into the ground. It is not intended to provide the continuous circuit required for bonding and should not be used to control static electricity.

9.2.8 Heated storage

Any combustible liquid that is heated and kept above its flash point shall be stored and handled in the same manner as a PG III flammable liquid.

If liquids are to be heated, controls shall be provided to prevent their heating to a temperature that could jeopardize the safety of the container or its contents.

Where liquids are heated during storage, operating procedures shall take account of the following:

- (a) Where the temperature of the liquid could approach that at which cracking, decomposition, polymerization or ignition could occur, the vapour space in the container could be within flammability limits.
- (b) Any water present in the container could flash to steam and cause a boilover as the boiling point is approached. Any procedures for water removal shall be followed closely.
- (c) Sufficient ullage shall be allowed for thermal expansion.
- (d) Vapours shall be controlled to ensure that they do not create a hazard.

NOTE: Appendix J provides a table of characteristics of common flammable liquids.

9.2.9 Site upkeep

The area within any compound or in and around any store shall be maintained in a safe condition. The following requirements apply:

- (a) The area shall be kept clear of all extraneous materials.
- (b) Specified clearance distances shall be maintained at all times.
- (c) Packages shall not be placed where they could jeopardize entry and exit.
- (d) Vegetation that could become a fire hazard shall be kept short.
- (e) Any weed killer that is known to be a potential source of fire danger shall be used only with due care and precautions.
- (f) Any compound drain valve shall be kept closed and locked except during supervised drainage. A notice with the following words shall be displayed:

COMPOUND DRAIN VALVE—TO BE KEPT CLOSED AND LOCKED

- (g) The walkway of any tanker loading gantry shall be kept clear of extraneous materials.
- (h) Spills shall be cleaned up as soon as possible (see also Section 11).

9.2.10 Bunds and compounds

Bunds and compounds shall be maintained so as to retain their designated capacity and in a condition which will prevent the escape of liquid from the compound.

All bunds and compounds shall be kept free from extraneous combustible material, e.g. packagings, pallets, tree branches, leaves.

For earthen bunds, original height markers shall be checked regularly and the bund height maintained to those levels.

9.2.11 Doors and doorways

The following requirements apply:

- (a) Any self-closing door to a store or cabinet shall not be propped open.
- (b) Doorways shall be kept clear so as not to impede the closing of fire doors in an emergency.
- (c) The area to be kept clear around a fire door shall be clearly marked.

9.2.12 Commissioning of new, modified or repaired equipment

No equipment or installation shall be put into service unless a hazard identification and risk assessment has been undertaken to ensure that appropriate controls are in place. In addition, appropriate operating and emergency procedures shall be available and personnel shall have been trained in the operation of the equipment, recognition of fault conditions and actions to be taken if fault conditions occur.

9.2.13 Safety information

Material safety data sheets (MSDS/SDS), describing the properties of the liquids being kept or handled in the installation and the appropriate first aid measures for them, shall be readily accessible.

9.3 OPERATING PROCEDURES

9.3.1 General requirements

Safe systems of work, including procedures commensurate with the quantity and nature of the liquids being kept, shall be developed, documented and implemented.

Written procedures shall be appropriate to the installation and shall include the following:

- (a) A site plan (or plans) indicating tanks, plant, main pipework, switchboards or substations, emergency stop valves or actuating devices, fire protection systems and drainage.
- (b) Operating procedures, covering all aspects of the day-to-day operation of the installation.
- (c) Maintenance procedures, covering regular testing, inspection and monitoring of the equipment.
- (d) Emergency procedures, covering actions to be taken in the event of fire, spillage, accident, equipment failure or other abnormalities or emergencies (see also Section 10).
- (e) Construction and maintenance procedures, covering new facilities and repairs to and modification of existing plant.

NOTE: Many states have occupational health and safety legislation that provides for consultative mechanisms at workplaces, enabling management and workers to be jointly involved in the development of procedures and work practices.

Procedures shall be documented in notices, manuals or other recorded instructions as appropriate to the particular installation. They shall be either on view or readily available on site.

All personnel shall be trained in appropriate procedures (see also Clause 9.10).

All personnel shall comply with the procedures established for the installation. An audit system should be established to ensure compliance.

Procedures shall be regularly reviewed and modified as necessary, particularly following any equipment or organizational changes.

9.3.2 Operating procedures

Operating procedures shall include, but not be limited to, the following as appropriate:

- (a) Initial commissioning procedures.
- (b) Normal handling procedures.
- (c) Liquid transfer procedures.
- (d) Monitoring of essential functions and components.
- (e) Control of hazards, including ignition sources.
- (f) Manufacturer's operating instructions for equipment.
- (g) Earthing and bonding.
- (h) Fault conditions.
- (i) Housekeeping and site upkeep.

- (j) Isolation, deactivation and identification of equipment not in use.
- (k) Maintenance of clear spaces for access.
- (l) Management of leakage, spillage and clean-up.
- (m) Personnel safety and protective equipment.
- (n) Environmental monitoring.
- (o) Operation of utilities.
- (p) Fire protection systems.
- (q) Control of access, movement and activities.

9.3.3 Construction and maintenance procedures

These procedures shall include the following, as appropriate:

- (a) Work authorization, including the issuing of work permits.
- (b) Work in confined spaces.
- (c) Testing of instrumentation, protective devices, alarms and monitors.
- (d) Isolation and tagging of equipment.
- (e) Control of contractors.
- (f) Firefighting equipment.
- (g) Pipework.
- (h) Storage tanks.
- (i) Drainage systems and any separators.
- (j) Bunds.
- (k) Electrical equipment.
- (l) Ventilation systems.
- (m) Fences and security.
- (n) Lighting.
- (o) Signs and notices.
- (p) Plant components, e.g. pumps, fans, package filling equipment.

9.3.4 Emergency procedures

Documented emergency procedures and first aid procedures shall be prepared in accordance with Section 10 and Clause 9.13.

9.4 MANAGEMENT OF ABOVE-GROUND LEAKS AND SPILLS

9.4.1 General

Every endeavour shall be made to prevent leaks or spills, and to control them if they do occur. Clean-up action shall be initiated immediately. Leaked or spilled liquids shall be kept and disposed of in accordance with Section 12.

9.4.2 Clean-up materials and equipment

In order to deal with leaks and spills, a spill response kit shall be readily available where flammable or combustible liquids are stored, dispensed or in transit storage in order to prevent spills from reaching ignition sources, stores of other chemicals, or combustible materials (e.g. timber and paper), or flow into drains or onto neighbouring land, or enter any creek, pond or waterway.

A simple spill response kit should consist of some or all of absorbent pads, booms, loose absorbent and contaminated waste bags that are packed in a readily identifiable weather resistant container and are compatible with the liquids stored.

A spill response kit should also contain all personal protective equipment, as advised by the Safety Data Sheet of the liquids stored, broom and shovel.

Additional absorbent materials should be available, if required, to clean up the contents of the largest container kept, or the largest likely spill.

The following is a typical list of such materials and equipment:

- (a) Adequate quantities of absorbent material, e.g. absorbent pads, loose absorbent or suitable proprietary substances.
- (b) A sufficient number of resealable waste-recovery containers, e.g. drums, made of materials compatible with the substances being kept and appropriately marked as being for emergency use only.
- (c) Portable pumps and decanting equipment.
NOTE: Petrol-powered or non-flame proofed electric pumps are unsuitable for use with flammable liquids.
- (d) Shovels.
- (e) Yard brooms.
- (f) Booms (on-ground and floating).
- (g) Drain covers and drain plugs.

Any absorbent material containing flammable liquids are normally regarded as wastes but might still be classified as dangerous goods. In such cases they shall be disposed of in accordance with Section 12 and in compliance with local and State or Territory law.

NOTE: It is unlikely that such wastes could be disposed of with general garbage destined for landfills.

9.4.3 Actions for dealing with leaks and spills

At every occurrence of a leak or spill, the emergency plan should be implemented and consideration should be given to notifying the emergency services.

Emergency services should be notified when—

- (a) the liquids have spread, or have the potential to spread, beyond the boundary of the installation;
- (b) it is beyond the resources of the occupiers to clean up the spill or leak effectively and safely;
- (c) the protective equipment is inadequate for dealing with the situation;
- (d) staff are not experienced in dealing with the situation; or
- (e) staff and the public are, or could potentially be, placed at risk.

Leaking packages should be positioned in such a manner as to stop or minimize the leak and, if necessary, should be moved to a safe location. The package should either be placed in a suitable container, for example an oversize drum, or its contents should be transferred to clean packaging. The exterior of such clean packaging should be clearly labelled.

Small spills on the floor, or on the walls or structures of a building, should be collected, absorbed, or diluted, as appropriate. Where spills are absorbed, the used absorbent should be placed in a suitable waste container for disposal in accordance with Section 12.

9.5 PLACARDING

9.5.1 Placarding of stores

Every installation in which flammable liquids are kept shall be placarded in accordance with relevant regulations. Signs and placards shall comply with Clause 3.9.2 and shall be maintained so as to be legible.

Placarding shall reflect the actual storage situation at any given time and shall be amended without delay.

These additional signs shall have lettering that contrasts with the background and be clearly legible from any access point. Unless otherwise required, signs shall comply with AS 1216 and AS 1319. Composite signs or graphic symbols complying with these requirements may be used.

9.5.2 Safety information

Safety information, intended principally for emergency services, shall be provided. The following information should be included:

- (a) The location of the emergency plan.
- (b) The location of the manifest.
- (c) The location of personal protective equipment and clean-up equipment.
- (d) The location of essential services and of the controls for their distribution.

Such information shall be available at the site's main entrance and at least one other entrance if there is more than one access point.

NOTE: This information may be provided on a safety information board. A pictorial layout of the site may also be required.

9.6 LIQUID TRANSFER

Quantities of flammable liquid exceeding 5 L should not be transferred from storage to point of use in open containers. Transfer should be made in closed containers or in purpose-made containers that are suitable for the liquid.

9.7 EFFLUENT CONTROL

Effluent control shall be provided in accordance with regulatory requirements.

9.8 CONSTRUCTION AND MAINTENANCE WORK

9.8.1 General

No construction or maintenance work shall be carried out where flammable and combustible liquids are kept, unless a hazard identification and risk assessment has been undertaken, appropriate controls are in place and with written authorization from a person designated for the purpose by the occupier of the premises.

Where there is any doubt about the safety of the intended procedures, the liquids shall be removed. In addition, appropriate operating and emergency procedures shall be available.

When maintenance work is to be carried out on equipment from an area where liquids are kept, such equipment shall be checked to ensure that no flammable or hazardous vapours or residues remain, prior to the maintenance work being carried out.

9.8.2 Routine work

Any routine, non-hazardous work shall be supervised in such a manner as to ensure its safe conduct.

9.8.3 Work permits

Except for routine, non-hazardous work, any work within the restricted area shall be authorized by means of a work permit.

A work permit shall include statements of the following:

- (a) The nature and extent of the work.
- (b) Any conditions to be observed.
- (c) Any personal protective equipment to be used.
- (d) The period for which the permit is valid.
- (e) Any necessary regular checking to ensure that the safety requirements and conditions remain in force, e.g. atmospheric monitoring.
- (f) Any necessary procedures and precautions in returning the area to normal service.
- (g) Any firefighting equipment required to be at hand.
- (h) Any spill response equipment required to be at hand.

A work permit may identify, within the restricted area, an open area in which major maintenance or construction work can be performed without further permission. Such an area shall be determined in relation to any storages and plant so that the unrestricted use of ignition sources does not create a hazard. The physical limits of such an area shall be clearly marked.

Considerable care is still required in a non-hazardous area, as some articles might contain residues or might be hazardous in themselves, regardless of their location. Examples of such articles are used tanks, pipes and containers.

9.8.4 Preparation of work site

The relevant site area and plant shall be prepared in a way that reduces the potential for fire, explosion, or exposure of persons to a hazardous substance.

Precautionary measures shall include the following, as appropriate:

- (a) Identification of both the equipment to be worked on and other affected equipment.
- (b) Depressurization and disconnection of such equipment.
- (c) Isolation and locking-off of the equipment from other equipment.
- (d) Purging of the equipment.
- (e) Where the work to be carried out may impact upon hazardous substances, the removal of those substances from the immediate vicinity.
- (f) Sealing-off of sewers.
- (g) Provision of appropriate fire-protection equipment.
- (h) Testing of the work environment for flammable or hazardous vapours and oxygen content.
- (i) Provision of appropriate spill response equipment.

9.8.5 Completion of work and commissioning

When the work is complete, and before the plant is returned to service, a check shall be made to ensure that—

- (a) the work has, in fact, been completed;
- (b) any temporary arrangements (e.g. bypass lines, blank flanges) have been removed;
- (c) all personnel and equipment are accounted for;
- (d) the work permit has been cancelled or signed-off as being completed; and
- (e) all related equipment and facilities, including bunds, scrubbing systems (where relevant) and fire systems are operational and have been inspected and tested appropriately.

9.8.6 Hot work

9.8.6.1 General

Any work involving cutting or welding by gas or electric arc or any non-welding work of equivalent risk (e.g. grinding, drilling, the use of percussion tools) shall not be undertaken within a restricted area unless—

- (a) a work permit has first been obtained; and
- (b) any flammable or hazardous residues or vapours have been removed.

The requirements of the AS 1674 series shall be observed in relation to any hot work undertaken.

9.8.6.2 Hot tapping

When a connection is to be welded to a tank or pipe containing flammable or combustible liquid and the tank or pipe cannot be isolated or gas-freed, hot-tapping procedures shall be carried out in accordance with a documented procedure authorized by a person experienced in the design of hot taps. Hot tap operators shall be trained in their use.

NOTES:

- 1 Hot taps on tanks can carry particular risks and need to be carried out in accordance with API Std 653.
- 2 When combustible-gas detectors are used for gas-free testing, the presence of toxic residues may not be indicated.
- 3 Where hot work is involved, particular attention should be paid to scale, rusts, coatings or deposits that could decompose or generate volatile products upon heating. The use of combustible gas detectors for gas-free testing will not indicate the presence of such deposits.

9.8.7 Work inside a confined space

The requirements of AS/NZS 2865, including the issuing of a work permit, shall apply whenever a person is to enter or work in a confined space.

9.8.8 Grass cutting

Any use of a grass cutter in a restricted or hazardous area shall be covered by a work permit and shall be subject to the following conditions being observed:

- (a) No flammable or combustible liquids shall be transferred while the grass is being cut.
- (b) There shall be no leaks, spills or pools of liquid on or near the area to be mowed. Any such occurrences shall be cleaned up prior to mowing (see also Clause 9.4).
- (c) Grass cutting shall not be carried out within 3 m of any open-topped separator pit.
- (d) Tank valves shall remain closed.

- (e) Grass shall not be cut in still weather conditions.
NOTE: Air movement will assist vapour dispersal.
- (f) The lawn shall be thoroughly inspected and any foreign objects that could contact the cutting blades shall be removed prior to mowing.
- (g) The grass cutter shall be checked prior to use to ensure it is in good condition.
NOTE: The check should ensure that—
 - (a) the blades are securely attached;
 - (b) the spark plug lead is securely fastened and fully insulated; and
 - (c) the muffler is in good condition and generally free from rust particles.

9.9 GAS-FREEING OF TANKS AND PACKAGES

9.9.1 General precautions

The general safety measures set out below shall be observed when gas-freeing tanks, irrespective of the method employed. These procedures shall be applied where appropriate to the gas-freeing of packages:

- (a) The tank shall be emptied and cleaned as far as is possible before gas-freeing is commenced.
- (b) Gas freeing of tanks may create additional hazards not normally covered in the classification of hazardous areas according to AS/NZS 60079.10.1. Ignition sources shall be controlled in accordance with the normal requirements for hazardous areas and any additional allowances required for the gas freeing operations.
- (c) Any electrical equipment shall be selected and used in accordance with AS/NZS 60079.14 for hazardous areas.
- (d) The danger of ignition of any pyrophoric materials when air is admitted to the tank shall be taken into account.

Precautions to be observed when gas-freeing with air, water, steam and inert gas are given in Appendix K.

9.9.2 Effective completion

Any technique used to gas-free a space or container shall be sufficiently effective and shall continue for sufficient time, to ensure that the concentration of flammable vapour is nominally nil, but does not exceed levels for the work or tasks to be completed safely. For confined space entry, the levels specified in AS/NZS 2865 shall apply.

Additionally, if any person is required to enter the space, the concentration of any vapour shall be below workplace exposure levels unless appropriate personal protective equipment (PPE) is provided.

9.10 PERSONNEL TRAINING

9.10.1 Job knowledge

All personnel handling flammable or combustible liquids on the premises shall be made fully conversant with—

- (a) the means of identifying the liquids and the properties of the specific substance handled, by reference to the relevant material safety data sheet (MSDS/SDS); and
- (b) applicable safety regulations and safe-handling procedures.

9.10.2 Training

Personnel employed on the premises shall be trained as appropriate, in—

- (a) the nature of the work and safe methods of operation;
- (b) the properties and hazards of the substances handled;
- (c) the location of first aid equipment, and first aid measures to be taken;
- (d) the correct use of personal protective equipment, its care and maintenance;
- (e) actions (including evacuation procedures) to be taken in various emergencies, including spills, gas escape, fire and explosion;
- (f) control measures in place at the facility; and
- (g) the content and operation of the safety management system.

Simulated emergency exercises shall comprise part of the training (see also Section 10).

9.10.3 Contractors

Contractors and their staff shall be trained in the following, as appropriate to the specific task to be performed:

- (a) The safety rules of the installation, including any restrictions on movement, access, activities and use of personal protective equipment.
- (b) Conditions and obligations associated with work permits and confined space entry permits.
- (c) Hazards likely to be encountered, including any materials stored or handled on the site.
- (d) Procedures to be followed in the event of any incident, e.g. spillage, accident or fire.

9.10.4 Refresher training

Training procedures shall include provision for refresher training at sufficient intervals to ensure that capability is maintained.

9.10.5 Hygiene

All persons whose work involves handling flammable or combustible liquids shall comply with the following directions:

- (a) Do not introduce, keep, prepare or consume any food or drink, or use tobacco, in any area where the liquids are kept or handled.
- (b) After handling any liquids, always wash your hands before eating, drinking, smoking or using the toilet, and after work.
- (c) Immediately attend to injuries caused by contact, or suspected contact, with the liquids.

The above directions, or wording to the same effect, shall be prominently displayed in the work area.

9.11 RECORDS

Records shall be kept of the following:

- (a) Training and retraining (permanent record).
- (b) Equipment tests required by this Standard and its referenced documents.
- (c) In-service inspections (life of installation).
- (d) Drills (six years).

- (e) Maintenance and repairs (life of installation).
- (f) Fires, significant spillage, accident, injury, dangerous occurrence or other incident (life of installation).

NOTES:

- 1 The suggested periods for the retention of records are given in parentheses.
- 2 Regulations may require differing periods for the retention of such records.

9.12 PERSONAL PROTECTIVE EQUIPMENT (PPE)

9.12.1 General

Where flammable or combustible liquids are kept or handled—

- (a) all persons on the premises shall be provided with appropriate personal protective equipment;
- (b) personal protective equipment shall be kept in designated, well-identified locations and ready for use; and
- (c) all personal protective equipment shall be maintained in good condition.

9.12.2 Type of personal protective equipment

The following personal protective equipment shall be provided, as appropriate to the operational requirements of the site:

- (a) Protective clothing complying with AS/NZS ISO 6529 or AS/NZS ISO 6530, and suitable for use with the specific liquids being handled.
- (b) Eye protection, selected in accordance with AS/NZS 1337.
- (c) Protective gloves complying with the relevant parts of the AS/NZS 2161 series of Standards.
- (d) Safety helmets complying with AS/NZS 1801 and selected in accordance with AS/NZS 1800.
- (e) Safety footwear complying with AS/NZS 2210 (series).
- (f) Respirators having appropriate filters, and self-contained breathing apparatus (SCBA) complying with AS/NZS 1716 and selected, used and maintained in accordance with AS/NZS 1715.

NOTE: MSDS/SDS may provide further information on suitable personal protective equipment.

9.12.3 Care and maintenance of personal protective equipment

Personal protective equipment shall be kept separate from normal clothing. Maintenance of personal protective equipment and clothing shall be as follows:

- (a) After use, all personal protective equipment shall be maintained, cleaned and kept in accordance with the manufacturer's instructions, and as appropriate to the materials to which it has been exposed.
- (b) Safety helmets shall be maintained in accordance with AS/NZS 1800.
- (c) Respirators and self-contained breathing apparatus shall be maintained in accordance with AS/NZS 1715.

9.13 FIRST AID

A first aid station shall be provided in a clean area. It shall comprise, as a minimum, an appropriate first aid kit and first aid instructions, e.g. MSDS/SDS, for the liquids being kept or handled on the premises.

It is recommended that—

- (a) at least one person on the premises is trained in first aid; and
- (b) a list of persons trained in and responsible for administering first aid should be kept at the first aid station and displayed on notice boards throughout the premises.

NOTE: Work health and safety (WHS) regulations also apply.

9.14 ADDITIONAL REQUIREMENTS FOR THE STORAGE AND HANDLING OF PACKAGES

9.14.1 Suitability of packagings

9.14.1.1 Flammable liquids

Where packaged flammable liquids are to be transported, their packaging shall comply with regulatory requirements.

Where the packaging is only for use at the premises at which it is filled, it shall be—

- (a) constructed with sufficient strength and durability for such service;
- (b) constructed such that all components of the packaging that could come into direct contact with the liquid are compatible with the liquid; and
- (c) marked in accordance with WHS regulatory requirements.

9.14.1.2 Combustible liquids

Packages for combustible liquids shall be constructed with sufficient strength and durability for their intended service and of material that is compatible with the liquid to be contained.

9.14.2 Marking of packagings

Packages containing flammable or combustible liquids shall be marked in accordance with the relevant Australian State or Territory legislation.

9.14.3 Stacking of packages

For safe stacking, block stacks shall be restricted in height, having regard to the load bearing ability, design and quality of the package, e.g. sole or combination packaging. Other considerations include—

- (a) the method of stacking;
- (b) the design of the stacking; and
- (c) the safe working load of the pallets.

If it is possible for packages to fall outside the compound, restraints shall be provided.

9.14.4 Housekeeping

The following housekeeping procedures shall be established and maintained:

- (a) The aisles of the store shall be kept clear.
- (b) In order to prevent the accumulation of old stock that could deteriorate and become a hazard, stock integrity shall be monitored.
- (c) All packages shall be handled with care so that the possibility of leaks is minimized.
- (d) Packages shall be regularly inspected and when any signs of spill, leak or deterioration are observed, the suspect package shall be examined and rendered safe.
- (e) Minor spills or leaks shall be dealt with in accordance with Clause 9.4.
- (f) Labels shall be retained on emptied packages until the packages have been gas-freed or decontaminated, at which time the labels shall be removed or obscured.

9.14.5 Used packagings

9.14.5.1 General

Packages that have been partly or completely emptied of liquid shall be re-closed unless they have been decontaminated or gas-freed.

Partially empty packages (not including those that are nominally empty) shall be stored and treated as though they were full.

9.14.5.2 Nominally empty packagings

Packagings that are nominally empty (i.e. they might contain vapour or small amounts of liquid) shall be stored in compliance with the following requirements:

- (a) The location of the stored packages in relation to any boundary or structure shall provide for clear access not less than 1 m wide all around for site upkeep.
- (b) Storage areas for empty containers shall be identified.
- (c) Packages that are exposed to the weather shall be monitored for corrosion. Severely corroded packages shall be disposed of safely.
- (d) Spillage containment shall be provided for environmental reasons. Bunding is not necessary.

9.14.6 Process feedstocks and finished products

The storage of flammable liquids within a process area shall be limited to—

- (a) no more than two pallet loads or an aggregate quantity of 3200 L (i.e. two IBCs of up to 1.6 m³ capacity each) adjacent to the process; or
- (b) not more than 12 h supply, whichever is the greater, except where the flammable liquids are stored in a separate area that complies with this Standard.

Finished packages shall be cleared regularly throughout the shift. Any accumulated finished packages shall not exceed the output of one working shift.

NOTE: Appendix L provides additional recommendations for batch blending.

9.14.7 Handling precautions

The following precautions shall be observed when handling packaged liquids:

- (a) Packages shall be handled in a manner that will reduce the likelihood of spills and leaks.
- (b) Appropriate personal protective equipment (PPE), as specified in the appropriate material safety data sheet (MSDS/SDS), shall be available for use.
- (c) Where packages or IBCs are to be palletized, they shall be protected from the possibility of punctures or tears caused by splinters or nails in the pallets.
- (d) All movement of packages shall be subject to manual handling risk controls for the packages concerned.
- (e) Packages shall not be pressurized in order to transfer their contents.

9.14.8 Opening of packages

Sole or inner packagings shall not be opened inside a package store unless for the purposes of sampling, tinting, testing or inspection. Any package that has been opened shall not be returned to the storage area unless it has been securely closed.

9.14.9 Mechanical ventilation

Where mechanical ventilation is installed, the following procedures shall be established:

- (a) The times for starting, stopping and operating the system.

- (b) Procedures to be followed if the ventilation fails or needs to be shut down.
- (c) Any restrictions on activities adjacent to the ventilated areas, particularly when the ventilation is not working.

9.15 ADDITIONAL REQUIREMENTS FOR PIPING AND VALVE SYSTEMS

The following procedures shall be established:

- (a) Procedures for safe operation of piping, taking into account the nature of the liquid being handled.
- (b) Avoidance of the possibility of liquid being locked-off in a section of piping that does not have pressure relief, unless thermal expansion is unlikely.
NOTE: Non-return valves, blinds, spades and positive displacement pumps can have the effect of closed valves.
- (c) Any valve that is intended to isolate a hydrostatic relief valve shall be secured in the open position while the hydrostatic relief valve is in service.

9.16 ADDITIONAL REQUIREMENTS FOR PIPEWORK

Procedures for the installation and maintenance of any pipework within an installation shall be established. They shall take into account—

- (a) the nature, pressure and temperature of the liquids;
- (b) inspection and testing (assessing sections of pipework prone to degradation, including drains, dead legs, elbows, welds, idle and insulated lines);
- (c) flow rates;
- (d) pressure relief;
- (e) draining and recommissioning;
- (f) earthing and bonding;
- (g) supports;
- (h) blanking off and isolation;
- (i) freedom from leakage, undue movement, vibration and corrosion; and
- (j) correct and legible identification.

The storage facility should be able to demonstrate that the pipework has been inspected and records should be kept. The interval between inspections should be based on the past results.

9.17 ADDITIONAL REQUIREMENTS FOR TANKS

9.17.1 Inspection and maintenance of tanks, tank vents and fittings

Tank vents and fittings shall be inspected regularly, to ensure that pressure/vacuum (P/V) and emergency vent passages are clear and any relief valves are operating correctly. Such inspections shall be carried out at least annually or as necessary.

Where long bolt manhole covers or flanges are used, consideration should be given to the prevention of water ingress to the tank and corrosion between the flange faces. Measures shall be taken to ensure that the long bolts cannot be tightened down at a later date.

For tanks with integral secondary containment, procedures shall be in place to maintain the primary tank. These should include regular inspection of the tank and its fittings, and the checking for and removal of water from the primary tank.

Tank containers shall be regularly checked to ensure their integrity.

Valves shall be overhauled completely at periods not exceeding 10 years. Valves for Category 6 tanks shall be overhauled at least at each floor inspection. Table 9.1 specifies inspection frequencies for tanks, valves and fittings for tanks of Categories 5 and 6.

Maintenance inspections may be varied (i.e. more or less frequent) if a proven maintenance management system is in place and operating. The frequency of inspections may be varied if the following prerequisites are in place:

- (a) An auditable maintenance management system has been in place and operating effectively at the installation for at least five years. Records are available for this time.
- (b) Plant safeguard systems and critical alarms are listed and managed as part of the system.
- (c) A system for monitoring, review and improvement is in place.
- (d) For internal tank inspections, at least two floor inspections have been conducted, approximately 10 years apart, or over a period of time as varied as given below, without alteration to the tank floor. If floor plates have been replaced, then the previous inspection data shall not be used and data collection recommenced.

The interval between such inspections may be increased to a maximum of 20 years between internal floor scans if—

- (i) the last of the internal scans and inspections has shown that the calculated corrosion rate will satisfy the requirements of API Std 653 with regard to the thickness of the floor plate at the end of the inspection period;
- (ii) there has been no change to product allocation or specification that could alter the corrosion rate; and
- (iii) there has been no change to operating conditions.

NOTES:

- 1 For Category 4 tanks above-ground, the maximum interval between internal inspections should be 15 years.
- 2 Magnetic flux leakage floor scanning is the preferred method of floor inspection.
- 3 A properly engineered tank inspection and maintenance program should take into account—
 - (a) the tank design and its liquid contents;
 - (b) inspection and maintenance history;
 - (c) soil conditions and foundation or berm construction;
 - (d) site experience with underfloor corrosion;
 - (e) the application and monitoring of cathodic protection;
 - (f) stray currents (which can protect tank floors, giving a false idea of underfloor corrosion potential);
 - (g) surface coatings;
 - (h) temperature;
 - (i) methods of heating;
 - (j) the presence and type of insulation;
 - (k) tank settlement history
 - (l) other safeguards, e.g. ground water monitoring, location of facility, bunding; and
 - (m) the inspection methods used.

Table 9.1 specifies inspection frequencies for Categories 5 and 6 tanks and their components. This does not form a complete specification for tank inspection, and sites without the necessary experienced engineering back-up will need to seek advice on the implementation of an inspection and maintenance program. New inspection technology may be used, provided it is properly evaluated and its limitations understood and taken into account when evaluating the results obtained.

**TABLE 9.1
TANK INSPECTION SCHEDULE FOR CATEGORY 5 AND 6 TANKS**

Part of tank	Minimum inspection type	Standards	Purpose	Tank category	Maximum interval between inspection
Tank shell	Non-destructive testing	AS 2452.3	To prove continued structural integrity of the tank and ensure minimum plate thickness (see also Clause 9.17.1)	6	10 years
Other structural members					
Floor plates					
Roof plates	Visual	API Std 653	To check for shell deformation, tilting and floating roof operation	5 and 6	Monthly
Whole tank, including floating roof seals					
Valves and vents	Visual	AS 1940 (this Standard)	To ensure that fittings are operating correctly	5 and 6	Monthly
	Remove and test	AS 1692 API Std 2000			
Other fittings and appurtenances	Visual	AS 1940 (this Standard)	To ensure that fittings are sound and operating correctly	6	Quarterly
External foundations and tank supports	Visual	API Std 653	To check for erosion, settlement and structural deterioration	5 and 6	Yearly
Internal and external floating roof seals	Physical	API Std 653	To ensure that seal performance is within acceptable limits	6	10 years
Cathodic protection	Physical	AS 2832	To ensure that cathodic protection, if provided, is effective	6	10 years
Level controls	Physical	AS 1940 (this Standard)	To ensure that all alarms and shutdown mechanisms, if fitted, are operating correctly	6	6-monthly

NOTES:

- 1 Ultrasonic testing of tanks for structural integrity and thickness should be in accordance with AS 2452.3.
- 2 Visual inspection refers to a visual examination of the tank parts while physical inspection refers to visual inspection and appropriate tests to confirm the function and condition of the parts and identify any weakness, deterioration or faults.
- 3 Reference should be made to API Std 653 and API Std 2000.
- 4 Where tank integrity can be demonstrated by a documented risk-based approach, these periods may be extended.
- 5 Further guidance may be found in AS 4971.

9.17.2 Inspection and maintenance of Category 5 and 6 tanks

9.17.2.1 General

Any Category 5 or 6 storage tank, its foundations and fittings, shall be kept in a serviceable condition while the tank is in use. A permanent record of inspection and testing shall be kept. Table 9.1 specifies inspection and testing frequencies for Category 5 and 6 tanks.

NOTE: AS 4971 should be consulted.

9.17.2.2 Repair of defects

Where defects create local stresses that exceed the allowable limits, the tank shall not be operated unless either—

- (a) the tank is repaired; or
- (b) the filling level is limited to ensure that stresses are not exceeded and controls are in place to ensure that the tank is not filled past its revised filling level.

9.17.2.3 Limited filling height

Where a tank can only be operated with a limited filling height as determined under Clause 9.17.2.2(b), the following provisions shall apply:

- (a) The structural strength of the tank has been evaluated by a suitably qualified engineer.
- (b) The limited filling height does not stress the weakest part of the tank beyond allowable design limit.
- (c) Any testing or inspection is carried out by non-destructive examination of the shell plates and welds, taking into account any pitting, grooving or other imperfections.
- (d) Sufficient measurements of metal thickness have been taken and the minimum effective thickness of each strake has been determined.
- (e) Records of measurements and engineering details in Items (a) to (d) above are maintained in accordance with regulatory requirements.

9.17.2.4 Repairs

Any repairs shall restore the tank to a design standard for its proposed service.

9.17.2.5 Hydrostatic testing

After any structural repairs and prior to its return to service, the tank shall be hydrostatically tested in accordance with AS 1692. Hydrostatic testing is not required following minor repairs or repairs to fittings.

9.17.2.6 Floor plates

For Category 6 carbon steel tanks built to AS 1692 sufficient measurements of floor plate thickness shall be taken to ensure that the minimum thickness has been determined. Where the effective thickness at any point is less than 4 mm, the floor plate shall be repaired to a condition fit for service.

For tanks constructed from other materials, a design safety review shall be carried out.

9.17.3 Inspection and maintenance of Category 1 to 4 tanks and tank containers (ISO tanks) used as static storage

Procedures shall be established for the inspection and maintenance of tanks of Category 1 to 4, taking into consideration—

- (a) the condition of foundations and supports;
- (b) the integrity of the tank shell and tank floor;

- (c) serviceability of fittings, valves, vents and lines;
- (d) condition of welds, paintwork and surface condition; and
- (e) integrity of cathodic protection, if fitted.

For underground tanks, Items (a) to (d) do not apply.

Underground systems shall be maintained in accordance with AS 4897.

9.17.4 Emptying tanks

Where a portable pump is used to empty a tank for cleaning, repair or other purposes (e.g. taking the tank out of service for a short time), the following conditions shall apply:

- (a) The procedure is temporary and is covered by a work permit.
- (b) Where the pump is in a hazardous area or is pumping flammable liquid, the pump shall be suitable for use in the hazardous area, e.g. powered by air or steam, or manually or hydraulically driven.

Where electric motors or diesel engines are used, they and their associated cabling, control gear, and equipment shall be suitable for use in hazardous areas.

- (c) Portable pumps and hoses shall be earthed and bonded to dissipate static electricity.

The danger of ignition of any pyrophoric residues shall be taken into account when emptying a tank. The possibility of spontaneous ignition should not be overlooked; it might occur hours or even days after the materials have dried out.

9.17.5 Isolation of a tank

Any tank that is to be cleaned or repaired shall be isolated physically from any other tank or pipeline by—

- (a) removing a section of pipeline and blanking off the upstream connection; or
- (b) inserting a blank flange, as close as possible to the tank.

The tank shall also be isolated from any common vapour recovery system to which it is connected.

Closing a valve is not in itself an acceptable method of isolation. The isolation of a tank shall be covered by a work permit.

9.17.6 Disused tanks

An underground tank that has been taken out of service shall be either—

- (a) removed; or
- (b) completely filled with an inert solid material (e.g. sand, concrete).

All pipes shall be disconnected and removed from the tank, drained and the open ends sealed off.

NOTES:

- 1 AS 4976 provides further information regarding taking tanks out of service.
- 2 Additional EPA requirements may apply. The appropriate authority should be consulted.

9.18 BULK TRANSFER

9.18.1 General requirements

Safe filling and emptying procedures for tanks and tankers shall be established on the basis of the following requirements:

- (a) A normal filling level that allows for thermal expansion shall be established, and shall not be exceeded.

- (b) Filling and emptying flow-rates for which the tank vents were designed shall not be exceeded.
- (c) Filling shall be monitored and controlled so as to prevent the occurrence of overflow, spillage, or excessive pressure in the tank.
- (d) The recommendations of AS/NZS 1020 or IEC 60079-32-2, and the requirements of the ADG Code shall be observed wherever applicable.

9.18.2 Control of static electricity

The requirements of AS/NZS 1020 or IEC 60079-32-2 and the ADG Code, as appropriate, shall be observed when transferring flammable or combustible liquids into any container or tank to control and safely dissipate any static electricity generated during the operation.

9.18.3 Continuity testing

Tests shall be carried out to ensure that earthing and bonding is effective and that the resistance between a vehicle tank and earth is not greater than 1 M Ω , as follows:

- (a) For vehicle tank to loading structure—
 - (i) Where self-checking earthing verification systems are used as part of vehicle tank filling interlocks, this shall be considered sufficient to demonstrate the effectiveness of the connection between vehicle tank and earth (via structure) without additional earth testing.
 - (ii) The operation of self-checking earthing verification systems shall be tested at intervals not exceeding 12 months to verify correct functionality.
 - (iii) Where self-checking earthing verification systems are not used as part of vehicle tank filling (e.g. cable reel and clamp), the effectiveness of the connection between vehicle tank and earth (via structure) shall be verified by testing carried out at intervals of six months.
 - (iv) Where supported by a documented risk assessment, the test intervals specified in Item (iii) may be extended but shall not exceed 12 months.
- (b) For loading structure to earth—
 - (i) Testing shall be carried out at intervals of not more than 12 months to verify that the resistance between the (un-)loading gantry structure and the general mass of the earth is not greater than 1 M Ω .
 - (ii) Where supported by a documented risk assessment, the test intervals specified in Item (i) may be extended but shall not exceed 24 months.

9.18.4 Restrictions on vehicles in tank vehicle filling facilities

The following restrictions apply to vehicles in filling facilities handling flammable liquids:

- (a) A tank vehicle shall be positioned at all times so that in an emergency it can be driven or towed straight out without recourse to reversing.
- (b) The tank vehicle should be driven forward into the tank vehicle filling area rather than being backed in. Where the layout makes this impossible, so that reversing is unavoidable, a person shall be stationed to guide the driver while reversing.
- (c) No vehicle, including tank vehicles, shall be maintained or serviced whilst in the tank vehicle filling facility except for the refuelling of the vehicle running tank.
- (d) No vehicle, other than a tank vehicle, a vehicle associated with maintenance of the filling facility or an emergency services vehicle, shall be permitted to pass through or stand in a dedicated vehicle filling facility, consisting of two or more filling positions.

- (e) A tanker containing product shall not park or stand in or under a filling facility other than when filling or draining.
- (f) Where a flammable liquid spill occurs at the filling facility while a tank vehicle is standing therein, the vehicle engine shall not be started until the spill has been satisfactorily cleaned up, except in the case of an emergency.

The requirements of Items (c) and (d) may be varied by the use of a work permit.

Where a filling facility has been constructed for combustible liquids only and it is separated from a flammable liquid filling facility by more than 15 m, the requirements of Items (d), (e) and (f) shall not apply.

9.18.5 Bottom loading

A tank vehicle shall not be used for bottom loading unless it is constructed specifically for that purpose and complies with AS 2809.2 and API RP 1004 as appropriate.

When an overfill protection system either fails to operate or senses an overfill condition during a bottom loading operation, the overriding or bypassing of the system shall be authorized and supervised by a supervisor and then only to permit the compartments being loaded to be shut down and the tank vehicle removed. The bottom loading facility shall not be reactivated until any fault condition in the system or on board the tanker has been rectified.

9.18.6 Top filling

9.18.6.1 General

The following requirements shall apply when a tank vehicle is being top-filled through either a fixed internal filling tube or an open hatch:

- (a) Where a compartment is being filled without the use of a preset stop meter, a person shall only control the filling of a single compartment.
NOTE: A hatch or other opening to the compartment being filled may be left open during the liquid transfer operations to ensure the compartment is not filled beyond its safe filling level after allowing for drainage of the filling hose or piping.
- (b) No hatch or opening to any other compartment of the tank vehicle shall be open during the liquid transfer operation other than those compartments being filled.
- (c) All openings to a compartment just filled shall be closed before opening any other compartment of the same tank vehicle.
- (d) Any pipework or flexible hose shall be drained into the compartment just filled prior to disconnecting from the vehicle tank unless fitted with a dry-break coupling.

9.18.6.2 Filling through an open hatch

The following requirements relate specifically to filling through an open hatch:

- (a) Any rigid filling tube shall be kept in physical contact with the side of the hatch opening at all times during the liquid transfer operation and touch the bottom of the compartment. A hose shall not be used inside a compartment for filling.
- (b) On completion of the filling of a compartment a minimum time of two minutes shall elapse, then the rigid tube shall be carefully removed to permit complete draining and the avoidance of any spillage outside the hatch opening unless the tube is permanently fitted.

9.18.7 Switch-loading

When a flammable or combustible liquid is to be filled into a vehicle tank compartment which had previously contained a liquid having a lower flash point, the precautions outlined in AS/NZS 1020 shall be followed.

SECTION 10 EMERGENCY MANAGEMENT

10.1 SCOPE OF SECTION

This Section sets out requirements and recommendations on planning for emergencies. It applies to stores where the volumes of liquid stored are greater than minor storage and may be regarded as advisory for minor storage.

NOTE: The fire authority and other emergency service agencies should also be consulted.

10.2 PLANNING FOR EMERGENCIES

10.2.1 Considerations in designing premises

The likelihood of an incident occurring in an area used for storage and handling of dangerous goods can be minimized by good design and layout, sound engineering, good operating practices, and proper instruction and training of personnel in the performance of their duties.

The design and layout of the facility should consider the following provisions:

- (a) Sufficient space between bund walls, storage areas and other structures as will allow access for maintenance and during emergencies.
- (b) A means for reducing emission of vapours to the outside atmosphere.
- (c) Alarms connected directly to the fire brigade or 24 h monitoring services.
- (d) Water supplies.
- (e) Fire protection equipment.
- (f) A means of evacuation and assembly points.
- (g) Protection of personnel responding to an emergency.
- (h) Access routes for fire brigade appliances.
- (i) Containment of leaks, spills and run-off of firefighting water (see Clause 5.8 and Section 11).
- (j) The location of the emergency plan and safety information (see Clause 9.5.2).

NOTE: The emergency plan is described in Clause 10.2.2 below.

Where so required by the relevant regulatory authority, the fire authority and other emergency service agencies should be consulted with respect to the above matters.

10.2.2 Emergency plan

10.2.2.1 General

A detailed plan for combating emergencies that could occur on-site shall be prepared. Such a plan should be developed in consultation with the emergency services and relevant regulatory authorities.

The emergency plan shall—

- (a) take into account any potential for the occurrence of fire, explosion, natural disaster, reaction or release of dangerous goods;
- (b) be appropriate to the size and complexity of the installation, its resources and personnel; and
- (c) be regularly reviewed and updated as necessary.

Plant personnel shall be familiar with the contents of the emergency plan.

NOTE: Emergency services may require a copy of the plan to be kept at the site entrance.

10.2.2.2 *Review of emergency plan*

The emergency plan shall be kept up-to-date and reviewed and revised where necessary. For example, a review should be undertaken whenever—

- (a) a new type of liquid is introduced to the premises;
- (b) the quantity of liquids being kept is changed;
- (c) a change is made in the way the liquids are stored or handled;
- (d) a change is made in a process or procedure, which might result in a change of risk;
- (e) new information regarding the hazardous properties of a substance is established; or
- (f) problems are encountered during training or after an incident.

10.3 MANIFEST

A manifest shall be provided and maintained in accordance with relevant legislation.

10.4 PLACARDING

Stores shall be placarded in accordance with Clause 9.5.1.

SECTION 11 FIRE PROTECTION

11.1 SCOPE OF SECTION

This Section sets out requirements and recommendations relating to the protection of storages of flammable and combustible liquids from fire, and for the fighting of any fire in such storages.

NOTES:

- 1 This Section does not provide for fire protection facilities at marine tanker loading and unloading berths, which are dealt with in AS 3846.
- 2 It is essential that the requirements of all regulatory authorities, including the fire authority, be observed.

The protection of an installation from fire is achieved primarily by good facility design and operational practices which ensure that the possibility of the outbreak of fire is minimized, together with the minimum installed fire protection equipment specified in this Section so that consequences are also minimized.

11.2 APPLICATION OF SECTION

Any building or site where flammable or combustible liquids are stored or handled, in quantities exceeding minor storage (see Section 2), shall be provided with fire protection in accordance with this Section. Each installation shall comply with the general requirements of Clause 11.3 and the specific requirements of such other Clauses as are appropriate to the particular situation.

For facilities located outside of the built environment – typically farms, rural agricultural operations, mining operations both in rural and remote areas, etc., where a destructive fire will not endanger persons on or off the site, will not endanger any property under other ownership, or will not have the potential to cause serious environmental damage, the fixed fire protection requirements specified in this section may be varied and/or reduced, subject to a risk assessment conducted with or agreed to by, the authority having jurisdiction.

When the flash point or quantity of liquid stored is changed, the fire protection shall be upgraded to satisfy the requirements of this Section as appropriate.

11.3 GENERAL REQUIREMENTS FOR FIRE PROTECTION EQUIPMENT

11.3.1 General

Fire protection systems shall be appropriate to the hazard and include consideration of adjoining activities and materials, so as not only to deal with incidents within the storage but also to reduce the potential for the liquids to become involved through the escalation of another incident.

Individual package stores and tanks within the boundaries of a single property may be treated as separate storages for the purpose of determining total fire protection requirements, provided that all parts of the total storage are physically separated from each other by at least the distances given in Table 4.1 or Table 5.4, as applicable.

11.3.2 Equipment compatibility

Materials used in a fire protection system shall be suitable for the conditions of use and compatible with the liquids being stored. All firefighting media, appliances, equipment, components, hoses, connectors, booster connections, and the like shall be compatible with that of the local fire authority at all essential interfaces.

NOTE: Particular attention should be paid to provisions and procedures to cater for possible variations in the type of foam concentrate, mixing ratios, application methods and application rates.

11.3.3 Location of firefighting equipment

Any firefighting equipment shall be located so as to be reasonably adjacent to the risk being protected and accessible without undue danger in an emergency.

11.3.4 System integration

The fire protection facilities specified in this Section shall be either an independent system or integrated with other fire protection systems.

NOTE: Mutual aid in the form of a valved cross connection between neighbouring facilities to allow access to additional water supplies is acceptable, if approved by the relevant authority.

11.3.5 Weather protection

Any firefighting equipment that is susceptible to corrosion or degradation by weather, the environment, ultraviolet light, fumes and the like, shall be protected by a sheltered location or a protective enclosure, with the contents suitably labelled.

11.3.6 Labelling of firefighting equipment

All firefighting equipment shall be marked or labelled in accordance with the relevant Australian Standard. Other firefighting resources, such as water storage tanks, should be clearly identified.

NOTE: Advice may be sought from the fire authority.

11.3.7 System drawing illustrations

A layout plan showing the locations of all tanks, shut-off valves, pipelines, hydrants, and firefighting systems shall be provided and kept available for ready reference. Adequate wall-charts should be displayed in strategic control locations.

11.3.8 Equipment and piping identification

Firefighting equipment and piping shall be provided with the following means of visual identification:

- (a) Water piping and valves within the foam pumphouse—R13—Signal Red.
- (b) Pumps, above-ground piping, and valves containing foam concentrate—B15—Mid Blue.
- (c) Above-ground foam solution lines and valves within the pumphouse—B25—Aqua.
- (d) Outside hydrants and firefighting equipment—colours as in Item (a) or (c) and the word WATER or FOAM, as appropriate.
- (e) Cabinets containing firefighting equipment—painted in accordance with Items (a), (b) or (c), as appropriate.
- (f) Control points for water or foam—the word WATER or FOAM, as appropriate.
- (g) Sprinkler or Foam/Sprinkler system riser assemblies—colours as in Item (a) or (c) and the word WATER or FOAM, as appropriate.

NOTE: The colours specified are defined in AS 2700.

In addition to identifying piping colours, suitable labelling shall be provided as given in AS 1345.

11.3.9 Impact protection

All equipment, piping and valves shall be adequately supported and protected, taking into consideration the potential for traffic damage and projectile impact during a fire.

11.3.10 Maintenance of fire protection equipment

Fire protection systems and equipment shall be maintained in accordance with the relevant Section of AS 1851.

In addition the following requirements shall apply to the maintenance of foam systems:

- (a) At least annually, all foam systems shall be thoroughly inspected and checked for proper operation. The inspection shall include the quality of the foam concentrate or premix solution quality or both. Where results deviate by more than 10% from the manufacturers specification or that documented in acceptance testing, remedial action shall be instigated.
- (b) The inspection report, with recommendations, shall be filed with the owner. The requirements for performance evaluation of foam concentrate or premix solution shall be in accordance with the maintenance requirements of NFPA 11.
- (c) Any foam discharged during system commissioning or testing shall be contained so as to prevent release to the environment

NOTES:

- 1 The purpose of this inspection and testing is to ensure that the system is in full operating condition and that it remains in that condition until the next inspection.
- 2 Fixed discharge outlets equipped with frangible seals should be provided with suitable inspection means to permit proper maintenance and for inspection and replacement of vapor seals.
- 3 Appropriate non-fluorinated surrogate liquids should be used for testing as alternatives where possible.

11.4 PORTABLE FIRE EXTINGUISHERS

11.4.1 General

Fire extinguishers shall be provided in accordance with this Section as appropriate to the particular type of installation.

Any fire extinguisher shall comply with the appropriate Standard listed in Table 11.1, and shall be located and mounted in accordance with AS 2444.

TABLE 11.1
STANDARDS FOR PORTABLE
FIRE EXTINGUISHERS

Type of portable fire extinguisher	Standard
Foam type	AS/NZS 1841.4
Powder type	AS/NZS 1841.5
Carbon dioxide type	AS/NZS 1841.6
Wheeled fire extinguishers	AS 4265
Selection and location	AS 2444
Classification of extinguisher	AS/NZS 1850

11.4.2 Type and rating

The type and rating of any extinguisher required by this Standard shall be as follows:

- (a) Where the term ‘powder-type extinguisher’ is used it shall mean a portable powder-type fire extinguisher having a rating of at least 2A 60B(E).

NOTE: A capacity of 9 kg is recommended.

- (b) Where the term ‘foam extinguisher’ is used it shall mean a portable foam fire extinguisher having a rating of at least 2A 20B.

NOTES:

- 1 Fewer extinguishers may be provided in a specific area in order to reduce the total number of extinguishers nominated, provided that the overall rating is equivalent.

- 2 Although it is recognized that foam extinguishers cannot achieve a performance rating as high as is possible with other agents, foam is specified in certain applications where its characteristics are advantageous, e.g. ability to blanket spills, and to flow into corners otherwise difficult to reach. Nevertheless, substitution is permissible for rationalization, in which case the opportunity should be taken to raise the level of protection. Thus, a 20B foam type could be replaced by a unit having a considerably more effective rating, e.g. 2A 60B.

11.4.3 Limitations

Extinguishers shall be selected with the following criteria in mind:

- (a) Their suitability for use with the type of liquid on which it is intended to be used.
- (b) Alcohol-compatible foam shall be used for alcohol or other polar liquids.
- (c) Where powder-type and foam extinguishers are liable to be used together in an emergency, they shall be compatible.

NOTES:

- 1 Powder-type extinguishers have little cooling or quenching ability, so personnel should be aware of the potential for flashback or re-ignition.
- 2 Carbon dioxide can be adversely affected by wind, and so is more suitable for indoor and similar protected positions. Care needs to be taken in confined spaces.

11.5 FIXED FIRE PROTECTION AND DETECTION SYSTEMS

11.5.1 General

Any fixed fire protection or detection system shall be designed and installed in accordance with the appropriate Standard as listed in Table 11.2. Where any requirement in this Standard is more onerous than the requirements of the appropriate Standard, then the requirement of this Standard shall take precedence.

NOTE: Some Standards are not written for the prime purpose of protecting storages of flammable and combustible liquids, and the need to vary the requirements of such Standards is recognized. When consulting other Standards, care should be taken when selecting the appropriate portions of those Standards to be applied to the storage.

Detailed requirements and recommendations for foam systems and cooling water are provided in Clauses 11.14, 11.15, and 11.16.

TABLE 11.2
STANDARDS FOR FIXED FIRE PROTECTION SYSTEMS

System	Standard
Fire hydrant installations	AS 2419 series
Fire hose reels	AS/NZS 1221
Fire hose reel installations	AS 2441
Manual alarm call points	AS 1603.5
Pump-sets	AS 2941
Gaseous extinguishing systems	AS ISO 14520 series
Automatic fire detection and alarm systems	AS 1670 series
Automatic sprinkler systems—Wetpipe	AS 2118.1
Automatic sprinkler systems—Deluge	AS 2118.3
Low-, medium- and high-expansion foam systems	NFPA 11 or EN 13565-2
Water spray fixed systems	NFPA 15
Foam-water sprinkler and foam-water spray systems	NFPA 16

11.5.2 Fire detection, warning and alarm systems

Any fire alarm system shall comply with AS 1670 and AS 1603.5, together with the following requirements:

- (a) Any automatic system shall be capable of being manually activated at clearly identified positions.
- (b) The warning signal of the alarm system shall be sufficiently distinguishable from other signals to permit ready recognition, and shall be clearly audible throughout the whole installation, unless it can be demonstrated that audibility over a limited area is justified.
NOTE: In addition, a visual alarm system should be considered in areas of excessive noise.
- (c) The power supply for any alarm system shall be independent of the main electricity isolating switch for the area.
- (d) Any mandatory fire alarm systems shall be connected to a fire station nominated by the relevant fire authority or 24 h monitoring service. The latter shall immediately notify the nominated fire station in the event of the fire alarm being activated.
- (e) Manual alarm call points shall be located at convenient and safe locations near work stations.

11.5.3 Fire hose reels

Fire hose reels shall be installed when specified in various clauses in this Section and in Table 11.4. Fire hose reels shall comply with AS/NZS 1221 and AS 2441. Foam hose reels shall be fitted with suitable foam-making equipment capable of producing at least 27 L/min of foam solution at a minimum of 220 kPa for 30 minutes.

NOTE: To ensure appropriate application of foam, suitable training should be regularly undertaken.

11.5.4 Fire hydrants

Where fire hydrants are required to be installed by this Standard, the design and installation of the fire hydrant system shall be in accordance with AS 2419.1 for both buildings and open yards, as well as the additional requirements in this Section.

NOTES:

- 1 AS 2149.1 permits the use of street hydrants in lieu of onsite fire hydrant systems where the performance and location requirements of AS 2419.1 are satisfied.
- 2 The National Construction Code (NCC) in Clause E1.3 requires all buildings greater 500 m² in aggregate floor area to be served by a fire hydrant system.

NCC Clause E1.10 requires that special hazards need additional firefighting provisions for both buildings and/or allotments.

11.5.5 Automatic sprinkler systems and automatic foam/water sprinkler systems

Foam water sprinkler system design requirements shall comply with AS 2118.1 and their installation shall comply with NFPA 16. Refer also to AS 2118.3 for foam water deluge systems.

NOTE: Foam water sprinkler systems may be required for the protection of storage of flammable and combustible liquids in AS 2118.1 which specifies the design criteria, however specific installation requirements are not currently included in AS 2118.1 and NFPA 16 should be used.

11.5.6 Foam water sprinkler systems

Foam water sprinkler system design requirements shall comply with AS 2118.1 and their installation shall comply with NFPA 16. Refer also to AS 2118.3 for foam water deluge systems.

NOTE: Foam water sprinkler systems may be required for the protection of storage of flammable and combustible liquids in AS 2118.1 which specifies the design criteria, however specific installation requirements are not currently included in AS 2118.1 and NFPA 16 should be used.

11.5.7 Monitors

Monitors shall be installed as specified in various Clauses of this Section and shall comply with the manufacturer's specifications. The following requirements also apply:

- (a) Monitors shall be capable of applying the required water density and quantity to the storage under adverse wind conditions.
- (b) Fixed monitors shall be provided with adjustable, constant flow, fog to straight stream nozzles so that the facility is suitably protected, but not damaged by solid stream at shorter ranges.
- (c) Monitors shall be located so that the facility is adequately protected.
- (d) If monitor location could endanger the operator, radiant heat protection or remote operation shall be considered. In any case, the design shall ensure that personnel operating monitors shall not be exposed to radiant heat flux of greater than 3 kW/m² or a radiant heat flux agreed to by the relevant regulatory authority.

NOTE: Determination of operator endangerment should take into consideration relevant technical and work, health and safety guidance for first responders. The radiant heat flux of 3 kW/m² aligns with the fire services requirements for up to 10 min operation.

11.6 FIRE EXTINGUISHER REQUIREMENTS FOR PRODUCT PUMPS, MANIFOLDS AND HOSE CONNECTION POINTS

11.6.1 Product pumps

A pump installation for handling flammable or combustible liquids shall be provided with at least one powder-type extinguisher not less than 3 m nor more than 10 m from each risk being protected.

11.6.2 Manifolds and hose connection points

Except as otherwise required by this Section, a powder-type extinguisher shall be provided within 10 m of a hose connection point or a manifold.

11.7 FIRE EXTINGUISHER REQUIREMENTS FOR TANK VEHICLE TRANSFER AREAS

11.7.1 Location of extinguishers

The positions of extinguishers shall be chosen to optimize access in an emergency. The following considerations should be taken into account:

- (a) At least one powder-type extinguisher should be at ground level at each loading position. For a top-loading installation at least one additional powder-type extinguisher should be at the loading platform.
- (b) All foam type extinguishers should be at ground level within 10 m of the loading point.
- (c) Locations should be on approach or exit paths.
- (d) Access to any extinguisher should not be vulnerable to blockage by a fire.

11.7.2 Road tank vehicle loading areas

An installation for filling road tank vehicles with flammable liquid shall be provided with the following minimum fire protection:

- (a) For top loading, one powder-type extinguisher per vehicle loading position located on the platform plus one powder-type extinguisher for each set of access stairs.
- (b) For bottom loading, one powder-type extinguisher for each vehicle loading position.

- (c) In addition to Items (a) and (b), one foam extinguisher for every two vehicle loading positions or part thereof.
- (d) Where a road tank vehicle consists of more than one tank unit (e.g. a B-Double or road train), Clause 11.7.3 shall apply.

11.7.3 Rail tank vehicle loading areas

An installation for filling rail tank vehicles with flammable liquid shall be provided with the following protection:

- (a) When filling a single tank vehicle, or two tank vehicles on parallel sidings from a common elevated platform, Clauses 11.7.2(a) and 11.7.2(c) shall apply.
- (b) When filling two or more tank vehicles in line from a common platform, the following shall be provided:
 - (i) At least one powder-type extinguisher for every 15 m or part thereof of platform length.
 - (ii) One powder-type extinguisher and one foam extinguisher at the foot of each set of access steps to the platform.
- (c) Where bottom loading takes place, at least one powder-type extinguisher shall be provided for each loading point or group of loading points, plus one foam extinguisher for each two loading points or for each two groups of loading points.

11.7.4 Tank vehicle delivery locations

Any location at which a tank vehicle will unload flammable liquid shall be provided with at least one powder-type extinguisher per unloading point or grouped set of unloading points with a minimum of two powder-type extinguishers for the installation.

NOTE: Where the location of the unloading area in relation to the storage renders it inadvisable to locate the extinguishers permanently at the tank vehicle standing area, they may be taken to that area for the unloading period.

For rail tank vehicle unloading, a minimum of one powder-type and one foam type extinguisher shall be provided for every two rail tank vehicle unloading positions.

11.8 FIRE PROTECTION REQUIREMENTS FOR PACKAGE STORAGE AND HANDLING AREAS

11.8.1 Application

This Clause (11.8) provides fire protection requirements for package storage and handling areas, as described in Section 4.

11.8.2 Package storage areas

Unless exempted by the provisions of Clause 11.2, a package store of greater aggregate volume than minor storage, or of any type other than an indoor storage cabinet shall be provided with fire protection in accordance with Clauses 11.4 and 11.5 and Table 11.3.

NOTE: Specific advice on automatic sprinkler systems for indoor stores of packages and IBCs may be found in AS 2118.1, which addresses package size, container materials, physical properties, stack types (on floor or in racks), storage heights and spacing.

11.8.3 Indoor storage cabinets

Each indoor storage cabinet having a capacity of 250 L or less, at least one powder-type extinguisher shall be provided. For indoor storage cabinets of more than 250 L capacity, an extra extinguisher or foam hose reel shall be provided. All extinguishers shall be located not less than 3 m or more than 10 m from the cabinet.

11.8.4 Package filling areas

In areas where packages are filled, with or without an associated storage, extinguishers shall be provided as follows:

- (a) For every filling point for flammable liquids, or for any two such filling points that can be circumscribed by a 5 m diameter circle, one powder-type extinguisher plus one foam extinguisher shall be provided. A foam-equipped hose reel may be substituted for any foam extinguisher within reach of the hose.
- (b) For every filling point for combustible liquids or group of filling points within a 5 m diameter circle, one powder-type extinguisher within 10 m of the filling point.

11.8.5 Storage of IBCs

Where IBCs are kept in a package store (as described in Clause 4.7), then fire protection for the appropriate type and size of package store shall apply, as listed in Table 11.3. Where IBCs are not stored in accordance with Clause 4.7, then fire protection shall comply with the relevant Clauses regarding tank storage, dependent on the total volume of liquid stored.

NOTE: For sprinkler protected package stores, specific requirements for the protection and storage requirements of IBC can be found in AS 2118.1.

11.8.6 Transit storage

For transit storage (as defined in Clause 1.4.72 and described in Clause 3.10), the requirements of Table 11.3 shall apply.

TABLE 11.3
FIRE PROTECTION FOR PACKAGE STORES

Type of storage	Quantity, m ³	Flammable liquid	Combustible liquid
Unroofed	≤2	1 × Unit 1 or 1 × Unit 4	1 × Unit 1
	>2 to ≤10	1 × Unit 1 1 × Unit 4	1 × Unit 1
	>10 to ≤100	4 × Unit 1 2 × Unit 4 Unit 5 Unit 7	1 × Unit 1 2 × Unit 4
	>100 to ≤200	4 × Unit 1 2 × Unit 4 Unit 5 2 × Unit 7	4 × Unit 1 2 × Unit 4 Unit 5 Unit 7
	>200	4 × Unit 1 2 × Unit 4 Unit 5 3 × Unit 7	4 × Unit 1 2 × Unit 4 Unit 5 2 × Unit 7
Roofed	≤2	1 × Unit 1 1 × Unit 4	1 × Unit 1
	≥2 to ≤10	2 × Unit 1 Unit 2 2 × Unit 4 Unit 7	2 × Unit 1 Unit 2 2 × Unit 4
	>10 to ≤100	Unit 2 Unit 3 Unit 5 2 × Unit 7	2 × Unit 1 Unit 2 2 × Unit 4 Unit 7
	>100 to ≤600	Unit 2 Unit 3 Unit 5 3 × Unit 7	1 × Unit 2 Unit 3 Unit 5 2 × Unit 7
	>600 to ≤1000	Unit 2 Unit 3 Unit 6 4 × Unit 7	Unit 2 Unit 3 Unit 5 3 × Unit 7
	>1000	Fire safety study	Fire safety study

NOTES:

- 1 This Table relates to stores containing unopened packages or where single packages are opened momentarily for testing or sampling.
- 2 This Table seeks to provide for the capability of handling a fire in its incipient stages wherever it may occur within a storage apart from Unit 6, where the sprinkler system or foam water sprinkler system is designed to control a developing fire beyond its incipient stage. Some modification may be required to suit particular storage arrangements.
- 3 Where flammable and combustible liquids are stored together, the requirements listed in the flammable liquid column of this Table apply for the aggregate quantity.
- 4 See Clause 11.4.3 for special limitations and requirements for extinguishers.
- 5 References to a particular type of fire protection 'Unit' in this Table have the following meanings:
 - Unit 1: One powder-type extinguisher.
 - Unit 2: One powder-type extinguisher located at each doorway to the storage area.
Extinguishers may be located immediately inside external doors if access or security risks exist, subject to the provision of prominent signs detailing their location.
 - Unit 3: Powder-type extinguishers internally positioned to achieve a 15 m maximum travel distance.
 - Unit 4: One foam-type extinguisher.
 - Unit 5: Hose reel(s) with foam capabilities (see Clause 11.5.3), able to reach all parts of the storage (a hydrant with 38 mm hoses and equivalent foam-making facilities is an acceptable alternative for a hose reel provided personnel are trained in their use).
 - Unit 6: Automatic sprinkler system or foam-water sprinklers in accordance with AS 2118.1, protecting the whole storage area (see Clause 11.5.1 and Table 11.2).
 - Unit 7: 10 L/s water supply for the fire hydrant system in addition to the requirements of AS 2419.1. The number and locations of hydrants shall be in accordance with AS 2419.1 (see Clause 11.5.4).

11.9 FIRE PROTECTION REQUIREMENTS FOR FUEL DISPENSING INSTALLATIONS

11.9.1 Vehicle refuelling stations

Fuel-dispensing installations for vehicles shall be provided with at least two powder-type extinguishers. For a private installation containing a single dispenser, one such powder-type extinguisher shall suffice where flammable liquid is dispensed. Extinguishers may be omitted where only combustible liquid is dispensed.

11.9.2 Refuelling berths for small craft

An installation for refuelling boats with flammable liquid shall be provided with the following fire protection equipment:

- (a) One powder-type extinguisher and one foam extinguisher per dispenser or group of dispensers and located no more than 10 m from a dispenser.
- (b) One hose reel located on the on shore side of the jetty, complying with Clause 11.5.3, the nozzle of which is capable of reaching the nozzle of each dispenser on the same jetty or wharf, when the dispenser hose is fully extended for normal refuelling. The reel shall be at least 3 m from any dispenser.

The fire protection equipment specified in Items (a) and (b) shall be located between the shore access and the dispenser.

11.9.3 Refuelling installations for light aircraft

An installation for the refuelling of light aircraft (up to 15-seater planes) shall be provided with one powder-type extinguisher per dispenser or group of dispensers. Such an extinguisher shall be located within 10 m of the dispenser.

11.9.4 Extinguisher access and security

At installations dispensing to the public, the extinguishers shall be accessible to the persons refuelling. Such extinguishers may be protected from vandalism or unauthorized access by a break-glass screen or an equivalent, such as a hatch that is opened by an emergency alarm or shut-off actuator.

The break-glass screen or similar device shall be prominently marked with instructions for gaining access to the extinguisher.

11.9.5 Specific dispenser extinguishers

The extinguishers specified for fuel dispensers shall be additional to any extinguishers provided elsewhere on the site.

11.10 FIRE PROTECTION REQUIREMENTS FOR ABOVE-GROUND FIRE-RATED TANKS, TANKS UNDERGROUND OR IN CHAMBERS

Any tank that is fire-rated (see Clause 5.9.4), or installed underground or in a tank chamber may be operated without fire protection additional to that otherwise required for the site.

11.11 FIRE PROTECTION REQUIREMENTS FOR ABOVE-GROUND TANK STORAGE OF AGGREGATE CAPACITY LESS THAN 60 m³

11.11.1 Tanks within buildings

Where a tank containing flammable or C1 liquid is located within a building, but is not in a tank chamber, it shall be provided with at least one powder type extinguisher located within 10 m of the tank and hydrant protection as specified in Clause 11.5.4 and Table 11.4.

11.11.2 Tanks that form part of a blending plant, or contain potable spirits

If tanks containing flammable liquids are part of a blending plant, or contain potable spirits, they shall be provided with hydrant protection as specified in Clause 11.5.4, Table 11.4, and—

- (a) at least one powder-type extinguisher, located within 10 m of the tank; and
- (b) a hose reel equipped with foam induction facilities as described in Clause 11.5.3.

Where only C2 liquid is stored, the normal building fire protection provisions shall suffice.

11.11.3 Outdoor tanks

Any outdoor tank storage shall be provided with hydrant protection as specified in Clause 11.5.4 and Table 11.4, and the fire protection in accordance with the following requirements:

- (a) Where flammable liquid is stored with or without combustible liquid, fire protection facilities shall be provided in accordance with Table 11.4.
- (b) Where Class C1 liquid is stored without flammable liquid, but with or without Class C2 liquid, at least one powder-type extinguisher shall be provided if a single-tank installation, otherwise two powder-type extinguishers shall be provided.
- (c) Where only Class C2 liquid is stored, no specific fire protection provisions are required for the storage other than those required for the building or site.

TABLE 11.4

**FIRE PROTECTION REQUIREMENTS FOR ABOVE GROUND TANKS
STORING <60 m³ FLAMMABLE OR C1 COMBUSTIBLE LIQUIDS**

Individual tank capacity, m ³	Aggregate capacity, m ³	Water supply and fire protection per installation
<30	<60 (of C1)	10 L/s fire hydrant system
	≤30 (of flammable)	10 L/s fire hydrant system, and at least two extinguishers, one of which may be foam and the remainder powder
	>30 but <60 (of flammable)	20 L/s fire hydrant system, and at least one powder-type extinguisher plus a hose reel with foam
≥30 but <60	<60 (of C1)	20 L/s fire hydrant system
	<60 (of flammable)	20 L/s fire hydrant system, and at least one powder-type extinguisher plus a hose reel with foam

NOTES:

- 1 The minimum fire hydrant water supply flow rates specified in this Table are additional to the requirements of Clause 11.5.4.
- 2 Reference to a hose reel with foam means a hose reel to AS/NZS 1221 with foam-making branchpipe and pickup tube (see Clause 11.5.3).
- 3 This Table should be applied to tanks separated as required by Clause 5.7. Where tanks are separated as described in Clause 11.2, each tank or group of tanks should be treated individually for the purpose of using this Table.

11.11.4 Location

Unless otherwise specified, extinguishers shall be located within 10 m of the tank and shall be positioned outside of any bund.

11.12 FIRE PROTECTION REQUIREMENTS FOR ABOVE-GROUND TANK STORAGE OF AGGREGATE CAPACITY 60 m³ TO 2000 m³

11.12.1 Flammable liquids

Where flammable liquid is stored with or without combustible liquid, the following requirements shall be provided, in addition to the provisions for any other storage or building on the site, unless exempted or varied by Clause 11.2:

- (a) For clusters of tanks, Clauses 11.13.2 and 11.16 shall apply.
- (b) At least one powder-type extinguisher and hose reel with foam.
- (c) Fire hydrants complying with Clause 11.5.4 and the following:
 - (i) Suitable foam-making equipment shall be provided, capable of producing 240 L/min (4 L/s) of foam solution at a minimum pressure of 400 kPa.
 - (ii) Sufficient foam concentrate in containers to provide 20 minutes operation of the foam branchpipe in addition to any concentrate required for other purposes.
 - (iii) Sufficient length of hose of at least 38 mm size, to reach the compound and any road or rail tanker loading point, from a hydrant from either of two directions at least 90° apart shall be available. Where hoses have to be joined, not more than one length shall be 38 mm size. Additional lengths shall be at least 65 mm size, but there shall be no more than two lengths of hose per hydrant outlet. Hydrants shall be not more than 60 m from the tank.
 - (iv) The essential requirement is that satisfactory foam be generated, with an expansion ratio of at least 8:1.
- (d) Sufficient hydrants shall be provided in accordance with Clause 11.13.4.1(a).
- (e) The location of hydrants on the site shall be chosen on the basis of providing effective cover for each compound and any road or rail tank loading point in accordance with Clause 11.5.4, under any foreseeable conditions of fire and wind.

11.12.2 Flammable liquids associated with blending plants

NOTE: See Clause 11.11.2.

11.12.3 Potable spirits

NOTE: See Clause 11.11.2.

11.12.4 Class C1 liquid

Where Class C1 liquid is stored without flammable liquid but with or without Class C2 liquid, the installation shall be provided with—

- (a) a hose reel and foam-making equipment complying with Clause 11.5.3, for use where the water supply is adequate; or
- (b) two powder-type extinguishers plus additional sets of fire extinguishers shall be provided for multiple tank installations, as required.

The maximum travel distance to access a fire extinguisher shall not exceed 15 m.

11.12.5 Class C2 liquid

Where only Class C2 liquid is stored, the normal fire protection provisions of the building or site shall be sufficient.

11.12.6 Cooling water

Where any individual tank exceeds 500 m³ capacity, cooling water shall be provided in accordance with Clause 11.15.

11.13 FIRE PROTECTION REQUIREMENTS FOR ABOVE-GROUND TANK STORAGE OF AGGREGATE CAPACITY 2000 m³ AND GREATER

11.13.1 Foam systems for tanks

Every vertical fixed-roof tank over 6 m diameter that contains flammable liquid shall be provided with an automatic or manual fixed foam system in accordance with Clause 11.16, irrespective of whether an internal or external roof is provided for the tank, unless the use of foam is inappropriate (see Note 3). Foam shall be applied as directly as possible to the liquid surface.

NOTES:

- 1 Some authorities require that open-top floating roof tanks be provided with fixed foam systems, others do not, so it is necessary to determine the requirements for the locality.
- 2 For top application, Type II discharge outlets are preferred over those of Type I, due to their simplicity of operation and lesser maintenance requirements.
- 3 It is recognized that there may be special cases in which the use of foam is not advisable or is unnecessary, e.g. where the stored liquid is incompatible with foam or water, or where air is excluded by inert gas, or where a volatile liquid is stored in a pressure tank. Special consultation with the fire authority is necessary in any such cases.
- 4 On large or segregated sites, it may not be practical to have multiple proportioning and storage facilities. In such cases, it is acceptable to provide fixed foam piping to storage tanks from connection points outside the compound, to which mobile facilities can be attached. Consideration should be given to availability and access for such mobile facilities.

11.13.2 Foam protection for tank clusters

Where a tank cluster (see Clause 5.7.5) requires foam protection, but one or more tanks, because of the contents or the diameter, would not otherwise be required to be provided with a fixed foam system on the tank, provision shall be made to apply foam over the area of the compound, by means of monitors or hydrant systems. Where the cluster is located in a sub-compound within a larger compound, the foam requirements may be calculated on the basis of the area of the sub-compound, provided that the bund is at least 500 mm high and complies with Clause 5.8.3(h).

11.13.3 Cooling water

Cooling water shall be provided as required in Clause 11.15 (see also Appendix I).

11.13.4 Monitor and hydrant systems

11.13.4.1 *General*

A monitor and hydrant system shall be provided, which shall comply with Clause 11.14 and Clause 11.5.4, and the following requirements unless only combustible liquids are stored (in which case Clause 11.13.7 shall apply):

- (a) Fixed cooling rings or manually/remotely operated monitors shall be located such that water can reach every part of any tank requiring cooling water.

Fire hydrants shall be provided in accordance with Clause 11.5.4 to provide coverage for other storages, building, pumps, valves and other components of the installation.

- (b) Where any part of a pipe for water supply to a hydrant system lies within 150 m of any part of the storage as listed in Item (a), fire hydrants shall be placed not more than 60 m apart along that part of the pipe.
- (c) No fire hydrant shall be located within a compound unless the pipe to that hydrant can be isolated from the rest of the hydrant system by a valve outside the compound.
- (d) There shall be at least three hydrants per storage.

- (e) When planning the location of hydrants, the following points shall be taken into account:
 - (i) The possible need to apply further hydrants for auxiliary tank cooling, using either uncommitted reserve water or spare water (see Clause 11.15 and Appendix I).
 - (ii) The use of ring mains valve to retain 75% of the operational availability of the fire main at all times.
- (f) Non-fire-rated groove couplings shall not be used within a compound unless it can be safely accessed under fire conditions.

NOTE: The use of threaded sockets and fittings is not recommended, but where it is impractical to do otherwise, pipework should be back-welded for strength.

11.13.4.2 *Simultaneous operation of water-based systems*

When the cooling and foam systems with the largest demands are operating, the three adjacent fire hydrants that are not being used for cooling or foam and are the most hydraulically disadvantaged in the system, shall each be capable of providing pressure and flow in accordance with AS 2419.1.

11.13.4.3 *Hydrant accessories, hoses and fittings*

Where trained on-site personnel are available to operate a hydrant system, the following accessories, hoses and fittings shall be provided:

- (a) For each fire hydrant within the installation, at least one 30 m hose length of 38 mm minimum size, complete with couplings, together with one adjustable spray pattern hose nozzle having a capacity of at least 4 L/s, complete with hose coupling and hydrant valve spanners.
- (b) For each portable monitor, two 30 m hose lengths of 65 mm minimum size, complete with hose connectors and spanners.
- (c) One additional 30 m hose length of 65 mm minimum size for every three fire hydrants or part thereof, subject to a maximum of six additional hoses. Such additional hoses may be stored in a central location that is readily accessible at all times.
- (d) For every six fire hydrants, one foam-making branchpipe with pick-up tube, to a maximum of three units, with each branchpipe capable of producing 240 L/min (4 L/s) of foam solution at a minimum of 400 kPa.
- (e) Sufficient foam concentrate in containers to provide 20 minutes operation of each foam branchpipe as required in Item (d), in addition to any concentrate required for other purposes.

The accessories shall be housed at locations appropriate to the arrangements and the staffing levels of the particular installation, and shall be provided with identifying signs.

11.13.5 **Water supply duration**

Sufficient water shall be available from mains or static storage or a combination of both, to supply the sum of the requirements for cooling water for at least 1.5 h, plus the water requirements of the tank having the largest foam demand for at least 20 minutes or as designed. The water supply for the hydrant system shall be in accordance with AS 2419.1.

NOTE: If it is intended to take advantage of any convenient existing dam, river, lake or sea as static storage, the possible effects of short-term or long-term water level variations should be analysed as specified in AS 2419.1.

11.13.6 **Fire alarm system**

A fire alarm system shall be provided.

11.13.7 Combustible liquids

Where only combustible liquids are stored, the installation shall be provided with at least the following:

- (a) Sufficient hydrants to reach all parts of the compound.
- (b) Accessories and foam concentrate, as applicable.
- (c) One powder-type extinguisher per tank, with a minimum of three powder-type extinguishers for the storage area, strategically located around the storage.

11.14 PIPING AND PUMPING SYSTEMS

11.14.1 General

The requirements of this Clause (11.14) shall apply to hydrant systems, fixed foam systems and their water supplies.

11.14.2 Fire pumps

Where pumping is necessary to meet the performance requirements of the water supply or foam system, the requirements of AS 2941 and the following shall apply where appropriate:

- (a) Pumping arrangements shall be either of the following:
 - (i) Two automatic pumps, at least one of which shall be compression ignition engine-driven. The other may be electric motor-driven. Each pump shall be capable of providing independently the necessary flow and pressure.
 - (ii) Three automatic pumps, at least two of which shall be compression ignition engine-driven, and any two of which shall be capable of providing in aggregate the necessary flow and pressure.
- (b) Pump inlets may be interconnected by a common manifold where feasible, in which case isolation valves under the control of the site owner shall be provided in the common manifold.
- (c) For a pump-set boosting from a town main, there shall be a bypass around the pumps with a non-return valve on the bypass. The bypass shall be not less than the diameter of the pump discharge manifold.
- (d) The diameter of the water supply connection to the pumps shall be such that a velocity of 4.0 m/s is not exceeded when a pump is operating at its maximum flow rate.
- (e) Sufficient fuel shall be kept on-site to operate all pump engines continuously for six hours at maximum fuel consumption rates.
- (f) Where total water supply is from tank, with or without pumps, the tanks shall be either separate units or a single unit partitioned to hold 50% of the required water storage capacity in each tank or compartment (for the purpose of maintenance).
- (g) The location of fire pumps and associated equipment shall be determined in consultation with the authority having jurisdiction and in conjunction with the evaluation of heat flux contours generated from storage areas.

11.14.3 Strainers

Water and foam systems shall be provided with such strainers as may be necessary to prevent blockage of the equipment. Any such strainers shall be readily accessible and cleanable.

11.14.4 Piping

11.14.4.1 General

All pipework and fittings shall comply with AS 4041. Piping shall have suitable wall thickness, and shall be selected to anticipate internal pressure, internal and external pipe wall corrosion, and mechanical bending requirements.

11.14.4.2 Pipe materials

Within any hazardous area piping shall be of steel or other alloy rated for pressure and temperature. Steel pipe shall be not less than AS 1074 medium weight or Schedule 40 medium weight.

Galvanized pipe shall be used to conduct cooling water in atmospheres that are normally non-corrosive. Where corrosion could occur, piping shall be corrosion resistant or protected against corrosion. The quality of the water supply should also be considered, e.g. potable or raw water, and whether the pipe is normally dry or charged with water.

11.14.4.3 Foam system piping

Piping carrying or in constant contact with foam concentrate shall not be galvanized, and shall be constructed for material compatible with, and not affected by, the concentrate. The piping shall not have a detrimental effect on the foam concentrate.

11.14.4.4 Pipe supports and protection of pipework

The following requirements shall apply:

- (a) Pipe supports for sprinkler and deluge systems shall be provided in accordance with AS 2118 and AS 2419 series for hydrant and foam systems.
- (b) The supply piping to foam outlets that protect a given hazard in a fire area shall not pass over another hazard in the same fire area.
- (c) Where there is a possibility of explosion, pipework shall be routed to afford the best protection against damage.

11.14.5 Valves

Any manually-operated isolating valves used in a water or foam system shall be full-flow outside screw and yoke wheel gate valves or butterfly valves closed by turning the wheel clockwise.

The open and shut positions shall be obvious and the direction of closing clearly marked.

Where a valve for isolating or switching is underground, an aboveground open/closed indicator shall be provided.

For foam systems, both the injection line and concentrate feed line shall be fitted with isolating ball valves.

11.14.6 Backflow prevention

Where the foam system is permanently connected to the town's main potable water supply, backflow prevention or a water supply break-tank shall be provided in accordance with AS/NZS 3500.1.

11.15 COOLING WATER

11.15.1 Where required

Cooling water for the protection of tanks against fire exposure shall be provided in the circumstances described in, and in the quantities required by, Appendix I.

11.15.2 Methods of application

Cooling water shall be applied by means of fixed piping on the tank, or by manually/remotely operated fixed or oscillating monitors.

11.16 FIXED FOAM SYSTEMS FOR TANKS

11.16.1 General

The term 'fixed' in the context of this Clause (11.16) shall mean both 'fixed' and 'semi-fixed' as defined in NFPA 11.

Where a fixed foam system is required, it shall be designed in accordance with NFPA 11 or EN 13565-2 and the requirements of this Clause (11.16). Where there is conflict between NFPA 11 or EN 13565-2 and this Clause, the requirements of this Standard shall apply.

11.16.2 System controls

Controls for the initiation of the foam system shall be readily accessible. They shall incorporate a maximum three-step action, designed to be as simple as possible to operate as logically as possible.

Instructions shall be provided for the initiation, shutdown, flushing and reinstatement of the foam system. The instructions shall be permanent, clearly legible and located reasonably adjacent to the system controls.

For permanently-installed foam proportioning equipment, a block plan of the complete foam system and a schematic of the foam proportioning and distribution system shall be displayed adjacent to the foam system controls. The following information shall be provided as a minimum:

- (a) Foam concentrate quantity, type and mixing ratio.
- (b) Foam solution flow rates and pressures required for each protected tank.
- (c) Fire service water supply booster flow and pressure requirements.
- (d) Fire service foam concentrate injection point flow and pressure requirements.
NOTE: This only applies to systems using bladder tank storage.
- (e) Town mains and fire pump pressure and flow duty for annual water supply flow testing.
- (f) Any pressure switch or pressure relief valve settings.
- (g) Emergency and system maintenance contact details.

All valves that form part of the system controls to initiate the operation of the foam system or permit fire brigade shall be permanently marked to indicate their name or function.

The system shall be designed so that it can be adapted for fighting fires other than in the tank, e.g. a spillage or compound fire.

11.16.3 Foam system equipment

The following equipment associated with the preparation of foam shall be readily accessible and located outside any compound, in a position not exposed to the hazard to be protected:

- (a) Permanently-installed proportioning equipment.
- (b) Connections for water and concentrate for mobile foam-proportioning equipment.
- (c) Foam concentrate tanks.
- (d) Pumps and associated drives.

The positioning of the equipment is subject to agreement with the fire authority, with heat flux levels taken into consideration. If housed, the foam system and equipment shall be in a non-combustible structure.

11.16.4 Foam concentrate quantities

Sufficient foam concentrate shall be kept to ensure that the tank having the largest foam requirement can be supplied for a continuous period of not less than the following:

- (a) For a Type I discharge outlet foam application system—30 minutes for PG I or PG II liquid or 20 minutes for PG III liquid.
NOTE: Discharge outlets are described in Note 2 to Clause 11.13.1.
- (b) For a Type II or subsurface application system—55 minutes for PG I or PG II liquid or 30 minutes for PG III liquid.
- (c) For an installation in which the class of liquid stored is likely to change—the longer of the times specified above.
- (d) For a floating roof tank—20 minutes for ‘top of seal’ application, or 12 minutes for ‘below seal’ application.

NOTES:

- 1 When determining the quantity of foam concentrate required, the quantities of foam necessary to extinguish the fire and to provide a continuing seal over the liquid surface (to allow the liquid to cool below its re-ignition temperature) should be considered.
- 2 The storage volume may need to be increased to provide for possible additional demands, such as the volume necessary to fill the piping in any fixed foam solution reticulation system, or the needs of a hydrant-operated manual application system.
- 3 It is necessary to be able to replenish stocks of foam concentrate quickly, and within not more than 24 h. In the absence of an adequate nearby supplier, or common pooling arrangements with nearby installations, it may be necessary to store additional concentrate on-site.
- 4 Foam concentrate storage provisions may need to be designed to minimize possible long term deterioration of the foam concentrate and its storage container, e.g. by insulation or standing.

11.16.5 Foam concentrate storage

Foam concentrate shall be stored in accordance with the manufacturer’s data sheet, in either dedicated storage tanks or the manufacturer’s IBCs. The following requirements shall apply to such storage:

- (a) Any storage tanks for foam concentrate shall comply with the appropriate requirements of AS 2118.3.
- (b) The type, mixing ratio and quantity of foam concentrate shall be clearly and permanently marked on the storage vessel. Means shall be provided to readily determine the quantity of concentrate in the storage vessel at any time, and to draw liquid samples for annual testing.

NOTE: A sight glass may be used as a contents gauge, provided that any inlet to the glass below liquid level has a ‘loss of contents’ device fitted to guard against glass breakage.

- (c) The surface area in contact with air shall be minimized by providing a nozzle or dome in the top of the tank where the liquid surface is located when the tank is full.
- (d) The quantity of foam concentrate stored shall be maintained at all times, in volumes at least as required by Clause 11.16.4.
- (e) Provision for replenishing foam concentrate while the foam system is in use shall be provided. For bladder tank systems, a fire brigade foam concentrate injection point shall be provided, located in the concentrate feed line to the foam proportioner.

- (f) A reserve supply of concentrate shall be provided in separate tanks or manufacturer's IBCs on the premises, or available from an outside source within 24 h.

NOTE: The foam storage should be protected from heat and mechanical damage.

11.16.6 Product sealing

Discharge outlets shall be provided with a seal, frangible under low pressure, to prevent the entry of liquid or vapour from the protected tank into the foam supply piping.

Means shall be provided to allow for the inspection and replacement of such seals.

11.16.7 Foam concentrate compatibility

The type of foam used should be determined on the basis of compatibility with the liquid being stored and with other foam on site or available in a common pool. Foams generated separately from different types of foam concentrates may be applied to fire in sequence or simultaneously.

The foam concentrate, its storage and the proportioning equipment shall be mutually compatible. Different types of foam concentrate shall not be mixed for storage. Different brands of the same type of concentrate shall not be mixed unless the manufacturer's data indicates that they are compatible.

NOTES:

- 1 Only foams which have been independently tested and listed by a recognized testing organization as being suitable for use on the type of flammable liquid being stored should be used.
- 2 The foam used should be compatible with that used by the local fire authority except where the product stored demands a particular type.

11.16.8 System design requirements

Any fixed foam system on a storage tank shall comply with the following requirements:

- (a) The number of foam outlets shall be as given in Table 11.5.
- (b) The rate of foam application shall be as given in Table 11.6.
- (c) Foam inlet nozzles for fixed roof tanks shall enter—
 - (i) through the top strake, provided that the riser is designed and connected so as to allow for distortion of the upper strake and roof under fire or explosion conditions; or
 - (ii) through the second strake from the roof, with the interior pipe and discharge outlet not connected to the top strake or roof; or
 - (iii) through a low-level connection, or the product filling line, but above any established water bottom, for subsurface application.
- (d) Where two or more discharge outlets are required, they shall be equally spaced around the tank's perimeter, and each outlet shall be sized to deliver foam at approximately the same rate.

TABLE 11.5
FOAM OUTLETS FOR TANKS

Tank diameter, m		Fixed-roof tank			Floating roof tank	
Over	Up to and including	Number of outlets			Maximum spacing of outlets around pontoon circumference, m	
		Surface application	Subsurface application		Foam dam height, mm	
			Flammable liquid PG I or PG II	Flammable liquid PG III	300	600
0	24	1	1	1	12	24
24	36	2	2	1		
36	42	3	3	2		
42	48	4	4	2		
48	54	5	5	2		
54	60	6	6	3		
Over 60		One additional outlet for each additional 450 m ² of surface	One additional outlet for each additional 450 m ² of surface	One additional outlet for each additional 700 m ² of surface		

TABLE 11.6
FOAM APPLICATION RATES

Liquid stored	Foam solution application rate L/min.m ² of area of tank surface or foam dam annulus (see Note)				
	Fixed roof tank			Floating roof tank	
	Surface application		Subsurface application	Applied to annular foam dam only	
	Non-alcohol resistant foam	Alcohol-resistant foam	Non-alcohol resistant foam	Non-alcohol resistant foam	Alcohol-resistant foam
Hydrocarbons	4	4	4	12	12
Gasohols containing more than 10% alcohol by volume	—	6.5	—	—	12
Methanol, ethanol, and butanol	—	6.5	—	—	12
Acetone, MEK	—	6.5	—	—	12
Isopropyl ether, ethyl acetate, acrylonitrile	—	6.5	—	—	12
Other	As specifically determined for the material. See third party approval or manufacturer's recommendations based on specific fire tests.				

NOTE: Foam application rates specified in this Table are generic rates only. Specific brands of foam may have third party approved application rates which differ. Where such third party application rates exist, the rate used shall not be less than the one specified in the third party approval.

11.16.9 Foam system design limitations

11.16.9.1 General

The design requirements given in Table 11.6 shall be limited by the requirements of this Clause (11.16.9).

11.16.9.2 *Fixed roof tanks—Surface application*

The following requirements and recommendations apply:

- (a) Alcohol-resistant foams shall be used for gasohols and unleaded petrols containing more than 10% oxygenated additives (e.g. ethanol) by volume.
- (b) Flammable liquids having boiling points of less than 38°C may require greater application rates. Such rates should be determined from the manufacturer's data sheet.
- (c) Lower application rates should be used for high-viscosity liquids heated above 95°C, in order to reduce frothing and overflow of the stored liquid.
- (d) If the discharge outlet has a delivery rate of greater than 4 L/min/m², a proportionate reduction in the foam discharge time may be applied, provided that the period is not less than 70% of the minimum discharge time.

NOTES:

- 1 Extreme caution should be used when applying foams to tanks containing hot oils, burning asphalts, or burning liquids that have boiling points above that of water.
- 2 Although the comparatively low boiling point of the foam can beneficially cool such liquids at a slow rate, it can also cause violent frothing and overflow of the tank's contents.

11.16.9.3 *Fixed roof tanks—Subsurface application*

NOTES:

- 1 In addition to the control provided by the smothering effect of the foam and the cooling effect of the water in foam that reaches the surface, fire control and extinguishment can be further enhanced by the rolling of cool product to the surface.
- 2 Subsurface injection of foam is not recommended for liquids having a viscosity greater than 440 cSt at their minimum anticipated storage temperature.

The following requirements shall apply:

- (a) Subsurface injection shall not be used on—
 - (i) any hydrocarbon liquid having both a flash point of less than 23°C and a boiling point of less than 38°C; or
 - (ii) hydrocarbons containing greater than 10% polar solvents such as ethanol; or
 - (iii) other products requiring the use of alcohol-resistant foams, e.g. alcohols, esters, ketones, aldehydes, anhydrides.
- (b) The foam velocity for subsurface injection at the point of discharge into the tank shall not exceed—
 - (i) for PG I or PG II liquids, 3 m/s; or
 - (ii) for PG III liquids, 6 m/s.
- (c) Foams for subsurface injection shall have expansion ratios between 2:1 and 4:1.

NOTE: Not all types of firefighting foam are suitable for use in sub-surface injection systems. Confirmation of a foam's suitability for use in sub-surface systems should be sought from the supplier.

11.16.9.4 *Floating roof tanks*

Subsurface or semi-subsurface injection shall not be used for protection of open-top or floating roof tanks because of the possibility of improper distribution of foam at the liquid surface.

SECTION 12 WASTE STORAGE AND DISPOSAL

12.1 SCOPE OF SECTION

This Section sets out procedures for the safe storage and disposal of wastes, spills, damaged containers and items contaminated with flammable or combustible liquids.

12.2 STORAGE OF WASTES

Any installation in which flammable or combustible liquids are kept shall be provided with facilities for the storage of wastes and contaminated items. Such facilities shall comply with all of the requirements applicable to stores for flammable and combustible liquids.

12.3 WASTE MANAGEMENT

An assessment shall be made regarding the continued storage or appropriate disposal, which may include recycling, of the following items and liquids:

- (a) Wastes and residues from spills and leaks.
- (b) Liquids that cannot be identified.
- (c) Contaminated clothing and equipment.
- (d) Liquids that are in excess of possible use or demand.
- (e) Foam generated in test and emergency use or demand.

NOTE: The principles of pollution prevention and cleaner production should be applied in order to eliminate the generation of flammable and combustible liquid wastes. If elimination is not feasible, then re-use in a process or recycling should be considered. The only disposal options normally available are the use of the liquid as a fuel in very specific circumstances, or disposal by incineration.

12.4 WASTE DISPOSAL

Wastes shall be handled with the same precautions as those applying for flammable liquids.

Waste flammable liquids (e.g. used solvents) may be collected in a clean metal drum for a short time. The screw cap needs to be kept tightly closed at all times. Liquid should be poured in slowly using a metal funnel to reduce static electricity.

Any drum shall be labelled with the Class 3 dangerous goods 'diamond' and a clear indication of its contents e.g. 'waste acetone'. The drum shall be kept in a well-ventilated area at least 3 m away from any ignition sources.

Solid combustible waste (e.g. rags soaked with flammable liquid) may be kept in a clean, water-filled metal drum with a tightly fitting metal lid and labelled accordingly.

Wastes should not be allowed to accumulate, but should be removed by a specialist hazardous waste disposal contractor. Wastes containing flammable or combustible liquids, even at low concentrations, shall not be poured down to the stormwater drain or included with general garbage.

Where large volumes of waste solvent are generated, a portable recycling unit may be used.

12.5 PRE-DISPOSAL TREATMENT OF EMPTY CONTAINERS

Empty containers shall be rendered safe by cleaning, and then punctured or crushed.

12.6 METHODS OF DISPOSAL

If disposal is necessary, the local waste disposal authority, the environment protection authority and the health department, as appropriate, shall be consulted on the acceptability of the proposed method of disposal.

NOTE: Advice may also be obtained from the supplier of the goods, environmental service companies or waste disposal companies.

APPENDIX A
LIST OF REFERENCED DOCUMENTS

(Normative)

AS	
1019	Internal combustion engines—Spark emission control devices
1074	Steel tubes and tubulars for ordinary service
1170	Structural design actions
1170.4	Part 4: Earthquake actions in Australia
1216	Class labels for dangerous goods
1319	Safety signs for the occupational environment
1345	Identification of the contents of pipes, conduits and ducts
1530	Methods for fire tests on building materials, components and structures
1530.1	Part 1: Combustibility test for materials
1530.4	Part 4: Fire-resistance test of elements of construction
1580	Paints and related materials—Methods of test
1580.301.1	Method 301.1: Non-volatile content by mass
1603	Automatic fire detection and alarm systems
1603.5	Part 5: Manual call points
1670	Fire detection warning control and intercom systems—System design, installation and commissioning (series)
1674	Safety in welding and allied processes (series)
1692	Steel tanks for flammable and combustible liquids
1722	Pipe threads of Whitworth form (series)
1851	Routine service of fire protection systems and equipment
2118	Automatic fire sprinkler systems (series)
2118.1	Part 1: General requirements
2118.3	Part 3: Deluge systems
2129	Flanges for pipes, valves and fittings
2243	Safety in laboratories
2243.10	Part 10: Storage of chemicals
2359	Powered industrial trucks (series)
2419	Fire hydrant installations (series)
2419.1	Part 1: System design, installation and commissioning
2441	Installation of fire hose reels
2444	Portable fire extinguishers and fire blankets—Selection and location
2452	Non-destructive testing—Determination of thickness
2452.3	Part 3: Use of ultrasonic testing
2683	Hose and hose assemblies for distribution of petroleum and petroleum products (excepting LPG)
2809	Road tank vehicles for dangerous goods
2809.2	Part 2: Road tank vehicles for flammable liquids

AS	
2832	Cathodic protection of metals
2832.1	Part 1: Pipes and cables
2832.2	Part 2: Compact buried structures
2941	Fixed fire protection installations—Pump-set systems
3600	Concrete structures
3711	Freight containers
3711.6	Part 6: Tank containers
3961	The storage and handling of liquefied natural gas
4041	Pressure piping
4100	Steel structures
4265	Wheeled fire extinguishers
4775	Emergency eyewash and shower equipment
4897	The design, installation and operation of underground petroleum storage systems
4977	Petroleum products—Pipeline, road tanker compartment and underground tank identification
5092	CNG refuelling stations
AS ISO	
14520	Gaseous fire-extinguishing systems (series)
AS/NZS	
1020	The control of undesirable static electricity
1221	Fire hose reels
1337	Eye and face protection (series)
1596	The storage and handling of LP Gas
1715	Selection, use and maintenance of respiratory protective equipment
1716	Respiratory protective devices
1768	Lightning protection
1800	Occupational protective helmets—Selection, care and use
1801	Occupational protective helmets
1841	Portable fire extinguishers
1841.4	Part 4: Specific requirements for foam type extinguishers
1841.5	Part 5: Specific requirements for powder type extinguishers
1841.6	Part 6: Specific requirements for carbon dioxide type extinguishers
1850	Portable fire extinguishers—Classification, rating and performance testing
1905	Components for the protection of openings in fire-resistant walls
1905.1	Part 1: Fire-resistant doorsets
2161	Occupational protective gloves (series)
2210	Safety, protective and occupational footwear (series)
2229	Fuel dispensing equipment for explosive atmospheres
2865	Confined spaces

- AS/NZS
2906 Fuel containers—Portable—Plastics and metal
3000 Electrical installations (known as the Australian/New Zealand Wiring Rules)
3500 Plumbing and drainage
3500.1 Part 1: Water services
4766 Polyethylene storage tanks for water and chemicals
60079 Explosive atmospheres
60079.10.1 Part 10.1: Classification of areas—Explosive gas atmospheres (IEC 60079-10-1, Ed. 1.0 (2008) MOD)
60079.14 Part 14: Electrical installations design, selection and erection
- AS/NZS ISO
6529 Protective clothing—Protection against chemicals—Determination of resistance of protective clothing materials to permeation by liquids and gases
6530 Protective clothing—Protection against liquid chemicals—Test method for resistance of materials to penetration by liquids
- ISO
2592 Determination of flash and fire points—Cleveland open cup method
10497 Testing of valves—Fire type-testing requirements
- IEC
60079 Explosive atmospheres
60079-32-2 Part 32-2: Electrostatics hazards—Tests
60050 International Electrotechnical Vocabulary
60050-426 Part 426: Equipment for explosive atmospheres
- EN
13565 Fixed firefighting systems
13565-2 Part 2: Foam systems—Design, construction and maintenance
- ASME/ANSI
B16.5 Pipe flanges and flanged fittings
- NATIONAL TRANSPORT COMMISSION
ADG Code Australian Code for the transport of dangerous goods by road and rail
- AUSTRALIAN BUILDING CODES BOARD
NCC National Construction Code
- NFPA NATIONAL FIRE PROTECTION ASSOCIATION
11 Standard for Low-, Medium- and High-Expansion Foam
15 Standard for Water Spray Fixed Systems for Fire Protection
16 Standard for the Installation of Foam-Water Sprinkler and Foam-Water Spray Systems
- API AMERICAN PETROLEUM INSTITUTE
Spec 6FA Fire Test for Valves (R2011)
Spec 6FD Specification for Fire Test for Check Valves (R2013)
Std 607 Fire Test for Soft-Seated Quarter-Turn Valves
Std 653 Tank Inspection, Repair, Alteration and Reconstruction

API	AMERICAN PETROLEUM INSTITUTE
Std 2000	Venting Atmospheric and Low-pressure Storage Tanks: Nonrefrigerated and Refrigerated
RP 1004	Bottom Loading and Vapour Recovery for MC-306 & DOT-406 Tank Motor Vehicles
UN	UNITED NATIONS
Manual of Tests and Criteria	
Recommendations on the Transport of Dangerous Goods—Model Regulations	
UL	UNDERWRITERS LABORATORIES
2085	Protected Aboveground Tanks for Flammable and Combustible Liquids

APPENDIX B

RECOMMENDATIONS FOR THE DESIGN AND CONSTRUCTION OF BLENDING PLANTS

(Informative)

B1 INTRODUCTION

This Appendix provides recommendations for the location, design and construction of installations where flammable or C1 liquids are used in blending, in quantities greater than those specified for minor storage. It sets out provisions for the location of dedicated blending and mixing areas, buildings and vessels and their associated equipment and control rooms. These recommendations are additional to the requirements given in the body of this Standard.

B2 LOCATION OF BLENDING AREAS

B2.1 Blending areas outside of buildings

A dedicated blending area should—

- (a) be located at least 15 m from any on-site protected places outside the blending area;
- (b) be separated from protected places on adjacent properties by at least the distances specified in Table 4.1, but in no case less than 15 m; and
- (c) comply with AS/NZS 60079.10.1 with respect to distances from ignition sources.

NOTE: The 15 m separation distance addresses the minimum requirement by local fire authorities in emergency situations.

The separation distance (see Table 4.1) is based upon the maximum blending capacity at any one time and the highest hazard Packing Group that is to be used in the process area or building.

B2.2 Enclosed and partially-enclosed, single storey, non-fire rated blending buildings

NOTE: For the purpose of this Paragraph (B2), a roofed area with more than one wall enclosed is considered a building.

The separation distances set out in Paragraph B2.1 apply. Distances from ignition sources may be measured around vapour barriers.

B2.3 Single-storey blending buildings with fire rated walls

In such areas, the separation distances to other buildings specified in Paragraph B2.1 apply. Such distances may be measured around a fire rated wall.

B2.4 Multi-storey plants

In such areas, the separation distances given in Paragraph B2.2 and Paragraph B2.3 apply. In order to ensure building stability under fire conditions, the main structural members of a multi-level building should have an FRL of at least 240/240/240 wherever—

- (a) flammable liquids or bulk tanks are placed at levels above the ground floor level;
- (b) the building has a control room; or
- (c) personnel work within such a plant.

In other areas, structures do not need to be fire-rated, provided that the separation distances to on-site and off-site protected places exceed 25 m for a two storey structure and 50 m for any structure of three storeys or more.

The above distances are the minimum, unless exceeded by Table 5.4, based on the maximum aggregate quantity of flammable liquids capable of being blended at any one time.

B3 SPILLAGE CONTAINMENT

Spillage containment should be provided for all process areas, with a capacity of 25% of the total maximum processing volume at any one time. This containment needs to be capable of containing the output of any fire sprinklers over a 20-minute period.

Such containment may be either directly under the process area or should run off to an adjacent catchment area. Reference should be made to Clause 5.8.

B4 VENTILATION

With the exception of open-air process areas, any enclosed buildings should be provided with mechanical ventilation in accordance with Clause 4.5, except that the air transfer rate in the process area needs to be increased to 1.5 times the air transfer rate for storage areas.

Good design guidance would include a floor scavenging system meeting the requirements of Clause 4.5, in addition to dedicated systems at vapour release points. A system complying with Clause 4.5 alone generally would not be adequate in a blending area.

B5 HAZARDOUS AREAS

AS/NZS 60079.10.1 applies to blending areas. Electrical equipment needs to be suitable for use in that particular area.

B6 DESIGN CRITERIA FOR BLENDING AREAS

B6.1 Blending vessels

The following recommendations apply:

- (a) All blending vessels having a capacity of more than 500 L should be designed—
 - (i) to AS 1692 for tanks; or
 - (ii) to AS 1210 for pressure vessels.

Other Standards or codes may be used, provided it can be demonstrated that they are at least equivalent to the above Standards.

Specialized equipment such as high-speed dispersers, ball mills and variable speed agitators should incorporate the requirements of the above Standards.

- (b) Blending vessels should be located at least 600 mm apart and from the walls of the process building.

NOTE: A distance of 1 m is preferred, but 600 mm is the bare minimum to allow safe operation and service of such vessels.

- (c) The blending vessel's supports or legs should have an FRL of at least 120/120/120 if they are more than 1 m in height. Similarly, where process vessels are suspended on a mezzanine floor, the floor's supports should have an FRL of at least 120/120/120.
- (d) Any uncontrolled reaction should be able to be handled either within the reactor itself or transferred via a bursting/rupture disc to a nearby knockout drum or vessel.

B6.2 Blending areas

General walkways, platforms, piping and electrical wiring should be carefully planned to provide clean areas, free of hazards to the operators.

B7 CONTROL ROOMS

Where there is a control room associated with the blending area, the following recommendations apply:

- (a) Where the control room is less than 15 m from the process area, its walls should have an FRL of at least 60/60/60.

NOTE: If the control room is physically separated by at least 15 m from the process area, no special requirements apply with regard to FRL.

- (b) Where the control room is in a hazardous area, it should be under positive pressure. This system should be in continuous operation whenever flammable liquids are being processed.
- (c) Fresh air should be supplied to the room from a safe plenum located outside of the hazardous area (see also Paragraph B5).
- (d) The control room's ventilation system should be interconnected to either an air flow monitor in the supply duct or a positive pressure switch in the control room.

When such a switch is tripped, an audible and visual alarm should be activated within the room if it is occupied. Additional alarms should sound externally if the room is unmanned during long periods of automatic blending. Where pressure is not restored to the control room within a predetermined time, all electrical equipment not suitable for use in a hazardous area within the room needs to be shut down. This shut-down procedure needs to be designed to ensure that in any shut-down mode, the process can continue to operate safely or default to safe shutdown.

NOTE: IEC 60079-13 should be consulted.

- (e) Control rooms within multi-level process buildings should be carefully assessed, apart from the normal requirements for completely enclosing the room with fire-rated walls.

NOTE: A safe means of allowing operators and emergency services personnel to enter such buildings during an emergency should be considered.

B8 SAFETY REVIEWS

In designing such plants, the steps of Hazard and Operating Studies (HAZOP), safety review workshops and other safety process management system reviews should be carried out. These steps are vital to ensure that such plants are tested in a deliberate manner for all of the envisaged failure modes that could occur. This is to ensure that the plant will operate safely within the site and the surrounding environment.

APPENDIX C

USE OF FORK-LIFT TRUCKS AND VEHICLES NOT RATED FOR
HAZARDOUS AREAS IN FLAMMABLE LIQUIDS PACKAGE STORES

(Normative)

C1 INTRODUCTION

This Appendix sets out requirements for a system under which a fork-lift truck or similar vehicles not rated for hazardous areas may be operated in a Zone 2 hazardous area within a flammable liquids package store.

Such a package store shall comply with all relevant requirements of the body of this Standard, including:

- (a) Clause 1.1, Scope.
- (b) Section 3, General requirements.
- (c) Section 4, Package storage and handling areas, in particular Clause 4.10, Activities within package stores.
- (d) Section 9, Operational and personnel safety, in particular Clause 9.4, Management of leaks and spills, and Clause 9.10, Personnel training.
- (e) Section 10, Emergency management.
- (f) Section 11, Fire protection.

NOTE: The above list is not exhaustive.

C2 FACTORS CONSIDERED

The following factors have been considered when compiling the requirements set out in this Appendix:

- (a) The minimum ratio of floor to quantity stored provides sufficient volume of air to disperse any vapours (e.g. from minor leakage).
- (b) The restricted storage quantity limits the likely frequency of access by the fork-lift truck.
- (c) The restricted package size limits the magnitude of any spillage.
- (d) The restricted storage height reduces the likelihood of leaks and spills resulting from dropped and damaged packages.
- (e) The use of a checklist is intended to ensure that the fork-lift truck has no immediately obvious faults, and that no flammable vapours are evident in the package store when operations are commenced.

C3 SPECIFIC REQUIREMENTS**C3.1 Requirements for the package store**

The package store shall comply with the following:

- (a) The total volume of Class 3 dangerous goods (primary and subsidiary risk) stored shall be less than 25 000 L.
- (b) Liquids of PG I shall not be stored.
- (c) The package store shall have a floor area of at least 100 m² for every 1000 L of flammable liquid stored. In any case, the floor area shall be at least 100 m².

- (d) All packages shall be of a type that complies with the ADG Code.
- (e) Packages shall be kept tightly closed at all times.
- (f) Packages shall not be larger than 250 L.
- (g) Packages larger than 25 L shall be kept on pallets.
- (h) Packages shall not be stored higher than 2 m maximum drop height (i.e. the bottom of the highest package) above floor level.

NOTE: Pallets of 200 L drums may be stacked three-high.

C3.2 Requirements for the fork-lift truck

Any fork-lift truck that is to be used in the package store (as described in Paragraph C3.1) shall comply with the following:

- (a) The fork-lift truck shall be serviced and maintained in good repair.
- (b) The fork-lift truck shall carry a powder-like fire extinguisher in a quick-release bracket.
- (c) The fork-lift truck shall not be garaged, refuelled, charge or serviced within the package store.

C3.3 Procedures and work permit

The following procedures shall apply:

- (a) The fork-lift truck and the package store shall be inspected to ensure that they comply with the requirements of the relevant checklist before any work permit is issued.
NOTE: There may be a need to check behind any stacked packages or pallet racks in case any packages have fallen and spilt.
- (b) A work permit shall be in effect whenever a fork-lift truck is driven into or within the package store.
- (c) The work permit shall be valid only for the day or shift on which it is issued, and shall be re-validated each day or at each change of shift.

Following are two examples of work permits for issue when a fork-lift truck not rated for hazardous areas is to be used within a flammable liquids package store.

<p>Work Permit for Internal Combustion Fork-lift Trucks</p> <p>For premises:</p> <p>.....</p>
--

Fork-lift identification (registration or identification number).....

The fork-lift has been inspected and—

permission is given only for the day of issue or reissue of this permit for the fork-lift to enter the store(s) for Class 3 primary or subsidiary risk, as listed below:

	Day	1	2	3	4	5	6
<ul style="list-style-type: none"> • It does not have any apparent fuel or oil leak (e.g. with an LP Gas fork-lift, no gas smell, loose hose or pipe connections frayed or kinked hoses, loose cylinder fittings). 		<input type="checkbox"/>	<input type="checkbox"/>	<input type="checkbox"/>	<input type="checkbox"/>	<input type="checkbox"/>	<input type="checkbox"/>
<ul style="list-style-type: none"> • All electric equipment appears to be in good order (e.g. no broken light covers or globes, bare wires, loose connectors). 		<input type="checkbox"/>	<input type="checkbox"/>	<input type="checkbox"/>	<input type="checkbox"/>	<input type="checkbox"/>	<input type="checkbox"/>
<ul style="list-style-type: none"> • The exhaust system allows exhaust gas to escape only through the muffler tailpipe (e.g. no passing gaskets or joints, corroded or damaged exhaust manifold, pipe or muffler). 		<input type="checkbox"/>	<input type="checkbox"/>	<input type="checkbox"/>	<input type="checkbox"/>	<input type="checkbox"/>	<input type="checkbox"/>
<ul style="list-style-type: none"> • All tyres appear to be in good working condition. 		<input type="checkbox"/>	<input type="checkbox"/>	<input type="checkbox"/>	<input type="checkbox"/>	<input type="checkbox"/>	<input type="checkbox"/>
<ul style="list-style-type: none"> • The brakes appear to be in good working condition. 		<input type="checkbox"/>	<input type="checkbox"/>	<input type="checkbox"/>	<input type="checkbox"/>	<input type="checkbox"/>	<input type="checkbox"/>
<ul style="list-style-type: none"> • The fan belt and any other drive belt does not appear to be slipping. 		<input type="checkbox"/>	<input type="checkbox"/>	<input type="checkbox"/>	<input type="checkbox"/>	<input type="checkbox"/>	<input type="checkbox"/>
<ul style="list-style-type: none"> • The required fire extinguisher is in place on the fork-lift. 		<input type="checkbox"/>	<input type="checkbox"/>	<input type="checkbox"/>	<input type="checkbox"/>	<input type="checkbox"/>	<input type="checkbox"/>
<ul style="list-style-type: none"> • The fork-lift appears to be safe to use and free from defects that might be a source of ignition or cause a fire risk. 		<input type="checkbox"/>	<input type="checkbox"/>	<input type="checkbox"/>	<input type="checkbox"/>	<input type="checkbox"/>	<input type="checkbox"/>
<p>The store(s) identified below has been inspected and there are no apparent leaks or spills of flammable liquids.</p>		<input type="checkbox"/>	<input type="checkbox"/>	<input type="checkbox"/>	<input type="checkbox"/>	<input type="checkbox"/>	<input type="checkbox"/>

Permission is given only for the day of issue or reissue of this permit for the fork-lift to enter the store(s) for Class 3 primary or subsidiary risk, as listed below:

Store: _____ Store: _____

	Signed	Title	Date	Time
Day 1				
Day 2				
Day 3				
Day 4				
Day 5				
Day 6				

APPENDIX D

RECOMMENDATIONS FOR THE STORAGE AND HANDLING OF PACKAGED
FLAMMABLE LIQUIDS IN COOLROOMS

(Informative)

D1 INTRODUCTION

This Appendix sets out recommendations for the storage of packaged flammable liquids in coolrooms. These are additional to the requirements set out in the relevant Sections of the Standard.

D2 TYPES OF STORE

Cooled storage may be—

- (a) the entire flammable liquids store;
- (b) a partitioned section of the flammable liquids store; or
- (c) a modified flammable liquids cabinet.

D3 INSULATION

Materials used for insulation should not be capable of promoting a fire. The materials' potential for releasing toxic gases in a fire situation should also be considered.

Non-fire rated sandwich panels that could melt in a fire should not be used. Such panels, when made from polystyrene or polyurethane, are unsuitable for internal walls.

Insulating material should be protected against exposure to and absorption by liquids and vapours. The insulating material should be checked from time to time.

D4 VENTILATION**D4.1 Principles of ventilation**

Where ventilation in accordance with Clause 4.5 cannot be achieved, measures should be taken to—

- (a) prevent exposure to harmful atmospheres, e.g. concentrations of flammable vapour, or oxygen depletion;
- (b) identify any concentration of flammable vapour in air of 5% of LEL or more; and
- (c) remove any flammable vapours by forced extraction.

D4.2 Air replacement systems

The air removal system should comply with Clause 4.5.5. Where an external air supply cannot be used, air may be drawn from the surrounding store. Vapour detectors should be used to—

- (a) activate an alarm if the exposure threshold is exceeded; and
- (b) switch a continuously recirculating cool air system from recirculation to exhaust at 5% of LEL; or
- (c) activate air extraction fans if a high concentration of vapour persists for several minutes or if 10% of LEL is exceeded.

D5 COOLING SYSTEM REQUIREMENTS

The cooling system should comply with the requirements regarding hazardous area zoning and ignition sources given in Section 4. Materials of construction should not generate sparks.

Where a cabinet provides cooled storage, coils chilled with water or brine piped in from a water cooling unit may provide effective cooling.

For small rooms, domestic non-explosion protected airconditioners may be used if—

- their location complies with hazardous zoning requirements;
- they are hard-wired for fresh air intake only;
- at least 3 m of ducting is installed outside the store, between the air conditioner outlet and the air intake to the store; and
- in case of air-flow failure, there is a suitable device to automatically close off the duct from the airconditioner and open the duct to the atmosphere, in order to prevent any flammable vapours from being drawn back into the coolroom (see Figure D1).

D6 STORAGE BELOW FLASH POINT

Where flammable liquids are to be continually stored below their flash point, in order to exclude the need for classification of hazardous areas, a documented risk assessment should be carried out. The following items need to be considered:

- The temperature of the liquids should be maintained at least 10°C below the lowest flash point.
- Appropriate temperature monitoring, alarm and response systems should be provided and records of testing kept.

NOTE: A response system may include back-up refrigeration, removal to another storage or elimination of ignition sources.

- Any vehicle, equipment or goods brought into the store should not cause the temperature to rise above a specific, stated minimum.
- Spills and leaks of flammable liquids should be prevented from coming into contact with any surfaces that have not cooled to storage temperature. This may require special precautions for equipment such as forklifts.
- All electrical equipment within the coolroom needs to be suitable for use within a hazardous area as defined in AS/NZS 60079.10.1.

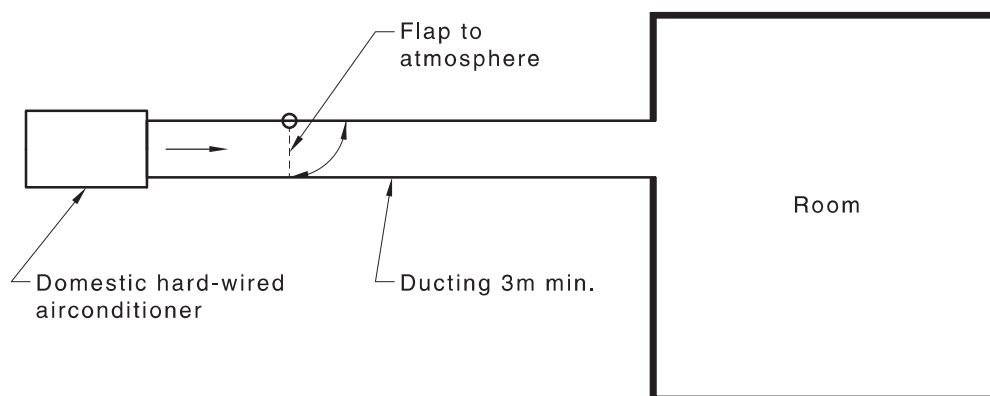

FIGURE D1 AIR COOLING SYSTEM

APPENDIX E
ISSUES TO BE CONSIDERED IN A RISK ASSESSMENT
(Informative)

E1 HAZARD ASSESSMENT

E1.1 Introduction

The following paragraphs outline the hazards that should be considered when planning a store for flammable and/or combustible liquids. A thorough assessment can help to detect and correct any potentially hazardous situations, and is best carried out using systematic methods including safety studies and check lists.

NOTE: AS/NZS ISO 31000 provides further information on risk management.

E1.2 Factors to be considered

When evaluating the suitability of a location for the store, the following features should be considered:

- (a) The nature and quantities of liquids to be kept on the site.
- (b) The manner by which the liquids are to be handled, including the type of equipment to be used (e.g. fork lift trucks rated for hazardous areas).
- (c) The store operator's technical, operational, organizational and emergency procedures and safeguards, including communications and emergency response.
- (d) Access to the store, including that required for normal transport operations, emergency response vehicles, and any evacuation routes.
- (e) Surrounding land uses, population densities and proximity to other hazardous installations.
- (f) The interaction of the abovementioned factors.

E1.3 Hazards presented by the liquids being stored

Flammable and combustible liquids can present the following potential hazards:

- (a) *Flammability*—the potential to burn or explode when ignited.
- (b) *Instability*—the potential to undergo a spontaneous reaction (e.g. decomposition, polymerization), which could be violent.
- (c) *Reactivity*—the potential to react with other chemicals, water or fire-extinguishing media.
- (d) *Toxicity*—the immediate, delayed or long-term health effects on humans or animals, through inhalation, skin absorption or ingestion.
- (e) *Environmental impact, including ecotoxicity*—the effect on the environment, in particular to aquatic life.
- (f) *Corrosivity*—the potential corrosive chemical action on other materials, in particular, packagings and living tissue (including skin).

Further information may be obtained from product labels, MSDS/SDS and the supplier of the liquids.

E1.4 Hazards presented by package storage conditions

The manner in which the liquids are stored should be considered. For package stores, these include the following conditions:

- (a) Storage arrangements, including—
 - (i) the volume of liquids in each storage;
 - (ii) stacking height and density;
 - (iii) palletizing pattern;
 - (iv) segregation of liquids having different hazards; and
 - (v) high-rack storage.
- (b) The nature of the packaging, especially where small packages are stored. Paper and plastics packagings can be highly combustible. The mechanical strength of the packagings is also important, as damage could lead to leaks and spills.
- (c) The design and construction of the store, fittings (e.g. lighting and heating), alarms and firefighting equipment.
- (d) Activities within the store, including maintenance, handling, introduction of ignition sources and other potential causes of incidents.

E1.5 Hazards related to the environment

The following hazards should be considered:

- (a) Proximity of the store to nearby industrial plants, hazardous installations, other dangerous goods stores, or traffic.
- (b) Natural events, e.g. floods.
- (c) Extreme climatic conditions, e.g. high or low temperature or humidity. These could affect the integrity of packagings or the stability of the liquids being stored.
- (d) Security of the store.

E2 RISK ASSESSMENT

E2.1 Introduction

A risk assessment is a systematic approach to the analysis of what can go wrong in a complex system. The normal conditions of operation are defined, and then the following questions are asked:

- (a) What events (e.g. accidents, incidents) can occur?
- (b) How frequently can they occur?
- (c) What are the consequences of each event?
- (d) What are the total risks (i.e. the probability and consequence of events) of the system?
- (e) What is the significance of the calculated risk levels?

These questions form the basic components of a quantitative risk assessment (QRA).

E2.2 Objectives of risk assessment

The primary objectives of risk assessment can be summarized as follows:

- (a) Determine the risks generated by activities within the store.
- (b) Prepare the structure of a safety management system.

- (c) Ensure the risk is maintained at an acceptable level. This may be by implementing controls.
- (d) Provide assurance to the operator, the regulatory authority and the public that the operations of the store do not pose an unacceptable level of risk.
- (e) Provide assurance that the safety management system is maintained and applied so as to achieve the above objectives.

E2.3 Risk analysis/assessment

Risk analysis/assessment involves the following basic steps:

- (a) System evaluation, in which information on the facility and the environment in which it operates, is collated and assimilated.
- (b) Hazard identification, in which events within and external to the store (which could lead to the release of hazardous material) are identified.
- (c) Frequency estimation, in which the likelihood of an event is estimated. This is normally based on historical data.
- (d) Consequence assessment, in which all possible consequences of each event are estimated.

E2.4 Risk reduction

If the risks are assessed as being too high, the system should be modified to attempt to reduce the risks to a tolerable level.

APPENDIX F
STORAGE AND HANDLING OF POTABLE SPIRITS IN BULK
(Normative)

F1 INTRODUCTION

This Appendix provides requirements that apply to the storage and handling of bulk potable spirits having an alcohol (ethanol) content of more than 24% v/v. These requirements are alternative to those given in Section 5, but apply only to those liquids as described above.

This Appendix covers the traditional methods of production used in the wine and brandy industries at existing installations. It has been derived from traditional methods of storage, and it is recognized that the level of performance requirements are lower than those that apply in the body of this Standard.

Installations at which potable spirits having an alcohol content greater than 60% v/v, quantities greater than 60 000 L, shall comply with the requirements of the main body of the Standard as appropriate.

New installations are advised to either comply with the body of this Standard (in particular, Sections 3 and 5) or carry out a risk assessment.

Where the requirements of this Appendix need to be varied, either Section 5 shall apply, or a risk assessment conducted and appropriate control measures implemented.

F2 LOCATION AND SEPARATION OF CONTAINERS

F2.1 Location

Containers may be located indoors or in the open air, with or without a roof.

Where they are located indoors, the following requirements apply:

- (a) Sufficient high and low level ventilation shall be provided, to ensure that the concentration of vapours from foreseeable spills or tank filling does not exceed 10% of the LEL.

NOTE: A minimum of 2% of the total area of roof and walls is considered adequate.

- (b) Where containers are to be installed in a multi-storey structure, a risk assessment shall be conducted to consider the possibility of vapour release and ignition, and steps shall be taken to mitigate or control the consequences.

Potable spirits may be kept in a multi-purpose building, provided that the vessels containing the flammable potable spirits are clearly marked and protected as required (e.g. tank venting, building ventilation and bunding).

F2.2 Separation distances

F2.2.1 *At wineries, distilleries and similar installations*

The following requirements apply:

- (a) The separation distance from the store to the boundary shall be sufficient to allow firefighting operations to be carried out from a safe distance and from two separate locations.
- (b) Where a room or office is inside the store and is used for the direct supervision of the store, the requirements of Clause 4.11 shall apply.

- (c) Any office or location where people congregate (e.g. a display or customer area) shall be separated from the containers by a distance of at least 5 m or by a barrier having an FRL of at least 120/120/120.
- (d) Clusters of tanks, barrels or vats are acceptable, provided they are accessible by firefighting equipment from a safe distance and from at least two directions.

F2.2.2 *At other locations*

The provisions of Sections 3 and 5 shall be observed.

F3 SPILLAGE CONTAINMENT

In rural areas, a means of confining a spill, for the purpose of environmental protection, shall be provided. Spillage containment shall be capable of retaining at least 100% of the volume of the largest container.

At all other premises, spill catchment shall be provided in the immediate vicinity of the container. Such a catchment shall be capable of retaining at least 110% of the volume of the largest container.

F4 CONTAINERS

F4.1 Materials of construction

Containers shall be constructed from a material which will not be detrimentally affected by the liquid being stored. Wooden containers are acceptable provided that the integrity of the liquid being stored can be ensured.

F4.2 Design of containers

The following requirements apply:

- (a) Containers shall be designed to withstand the load of their contents and any pressure and vacuum variations that could occur during normal operations.
- (b) Where a container will be installed in the open air, it shall be designed to take wind loading into account.
- (c) Any container with a capacity of more than 60 kL and intended to store liquids with an alcoholic strength greater than 60% v/v shall be designed to AS 1692 or other equivalent standard. Smaller tanks shall be designed so as to be fit for purpose.

F4.3 Installation of containers

The following requirements apply:

- (a) The container shall be installed upon a firm foundation.
- (b) A container shall be placed either directly on the floor, or on supports resting on the floor.
- (c) Any container installed out of doors shall be firmly secured to the ground.

F4.4 Vents

Wooden containers do not need vents, provided that operations are managed so that the container will not be pressurized beyond its design capability.

Other containers that have a capacity greater than 60 kL and that contain liquids having greater than 60% v/v alcohol shall have venting conforming to the requirements given in Section 5.

Where containers are kept within a room that has electrical equipment not rated for hazardous areas, a flame arrester shall be provided if the vent discharges into the room.

F4.5 Emergency fire relief vents

Emergency relief venting in accordance with Section 5 shall be provided for all containers except the following:

- (a) Wooden containers.
- (b) Containers installed in rural areas, or separated from boundaries by at least 15 m.

F4.6 Valves

The following requirements apply:

- (a) Valves shall be of a material that is compatible with that of the container, and shall not cause any electrochemical corrosion from the use of dissimilar materials.
- (b) All valves shall be located as close as possible to the shell of the container.
- (c) Valves shall be designed so that they cannot open by themselves. Plug cocks shall not be used, as the plug might be lifted from its housing by the head of liquid in the container.

F4.7 Level indication

Each storage tank shall be provided with a means of ascertaining the liquid level. If the indicator is of a type designed to be read at a remote location, additional facilities for checking its accuracy shall be provided. The maximum permitted filling level shall be indicated on the gauge.

Acceptable types of indicators include float gauges, hydrostatic pressure gauges, dipsticks or dip tapes. If a dipstick is used, it should be kept in or near to the container.

Where a tank contains a potable liquid having an alcohol content of 60% v/v or greater, the liquid level shall be monitored regularly and a high level alarm shall be fitted.

NOTE: Any change of contents of the tank may alter the maximum permitted filling level.

F4.8 Container identification

Every container shall be identified by a number.

F5 PIPES AND HOSES

Wherever possible, liquids shall be transferred using fixed pipework. The length of any flexible hose used shall be kept to a minimum.

Pipework shall comply with Section 6.

F6 ELECTRICITY EQUIPMENT

The area in which the potable alcohol is stored shall be classified into hazardous areas as described in AS/NZS 60079.10.1 and electrical equipment shall be selected so as to be suitable for use in that area.

F7 OPERATIONS

F7.1 Identification of stores

Where a liquid having an alcohol content of 24% v/v or greater is stored, the store shall display the Class 3 dangerous goods diamond.

F7.2 Filling of tanks

A written, displayed system of work shall be in place to ensure that the volume of liquid transferred is that which the receiving tank can safely accept.

A bulk container shall not be filled beyond its safe fill level. The information on the level of liquid in the container shall be available at the point where the transfer is to take place, or at a central control point.

It is preferable to have a constant indication of the liquid level in the container at the transfer point or central control point. If this is not possible, information on the ullage space in the container shall be available to the person conducting the transfer.

When potable spirit with an alcohol content greater than 60% v/v is transferred, a constant level indication or high level alarm shall be provided at either the transfer point or the central control point.

F7.3 Filling into road tankers or other transportable tanks

The requirements of the ADG Code shall be observed.

F8 FIRE PROTECTION

Fire protection should comply with Section 11. Any foam used in firefighting should be alcohol resistant.

APPENDIX G
POWER STATION AND GRID TRANSFORMERS
(Normative)

G1 INTRODUCTION

This Standard relates specifically to storage and handling and generally does not apply to electrical equipment which in normal operation uses combustible mineral oil as an insulating and cooling medium. However, the requirements of the Standard regarding containment of liquid spills apply in principle, since large volumes of oil can be involved.

Electrical equipment filled with combustible oil shall comply with the requirements of Clause 5.8, amended as set out below.

G2 SPILL CONTAINMENT

Spill containment shall be in the form of a tank, pond, or other storage. It shall—

- (a) have a net capacity not less than that of the largest single unit draining to it; and
- (b) be equipped with underflow discharge.

G3 COMPOUND DRAINAGE

Where a compound is provided with continuous drainage, draining shall be via a flame trap or traps to an oil spill containment facility.

G4 AUXILIARY EQUIPMENT

This Appendix does not apply to instrument transformers, circuit breakers, and similar items in outdoor switchyards.

APPENDIX H

TANK VENTING

(Normative)

H1 INTRODUCTION

This Appendix is derived from API 2000, converted to SI units. When more detailed information is required, the original document should be consulted.

H2 VENTING ATMOSPHERIC AND LOW-PRESSURE STORAGE TANKS

H2.1 Normal venting capacity

The total normal venting capacity shall be at least the sum of the venting requirements for liquid movement and thermal effect due to maximum change in atmospheric temperature.

Vacuum relief (in-breathing):

Total venting capacity (m^3/h) = 0.06 (maximum outflow, L/min) + column 2 of Table H1.

Pressure relief (out-breathing):

For liquid with a flash point of 38°C or above:

Total venting capacity (m^3/h) = 0.064 (maximum inflow, L/min) + column 3 of Table H1.

For liquid with a flash point below 38°C :

Total venting capacity (m^3/h) = 0.128 (maximum inflow, L/min) + column 2 of Table H1.

NOTE: Appendix J of API Std 620 states that the maximum inflow terms in the above formulas should be multiplied by the ratio of the absolute tank pressure to standard atmospheric pressure. This correction would be insignificant, and may be ignored, unless the tank pressure is substantially above atmospheric pressure.

TABLE H1
THERMAL VENTING REQUIREMENTS

Tank capacity m ³	Free air venting capacity (Notes 1 and 2) m ³ /h	
	Flash point <38°C	Flash point ≥38°C
10	1.8	1.2
15	2.7	1.6
20	3.6	2.2
50	9.0	5.4
75	14	8.0
100	18	11
200	36	22
500	89	54
1000	178	107
2000	356	214
3000	534	320
4000	683	427
5000	828	498
6000	925	569
7000	1031	640
8000	1140	684
10 000	1280	768
12 000	1420	852
14 000	1560	936
16 000	1700	1124
18 000	1845	1110
20 000	1980	1192
25 000	2290	1393
30 000	2645	1575

NOTES:

- 1 Interpolate venting capacity for tanks of intermediate size.
- 2 At 101.5 kPa (absolute) and 15°C.

H2.2 Emergency venting capacity

The emergency venting capacity shall be not less than that given in Table H2.

The total venting requirements determined from Table H2 or Note 4 thereof are based on the assumption that the stored liquid will have the characteristics of hexane, since this will provide results which are within an acceptable degree of accuracy for almost all petroleum liquids encountered. However, if a greater degree of accuracy is desired, the total emergency venting requirement for any specific liquid may be determined by the following equation:

$$\text{Emergency venting capacity (m}^3\text{/h)} = \frac{3100 q_v}{u\sqrt{M}}$$

where

q_v = emergency venting capacity from Table H2, in cubic metres per hour

u = specific latent heat of vaporization of the liquid, in kilojoules per kilogram

M = molar mass of the liquid, in grams per mole

Full credit may be taken for the vent capacity provided for normal venting, since the normal thermal effect can be disregarded during a fire, and it can also be assumed that there will be no liquid movement into the tank.

Under certain conditions an environment factor may be applied in the calculation of the rate of emergency venting required; reference should be made to API 2000 which outlines appropriate factors.

TABLE H2
EMERGENCY VENTING CAPACITY

Wetted area (Note 1) m ²	Free air venting capacity (Notes 2, 3) m ³ /h	Wetted area (Note 1) m ²	Free air venting capacity (Notes 2, 3) m ³ /h
1	321	35	8510
2	643	40	9200
3	964	45	9875
4	1286	50	10 450
5	1607	55	11 010
6	1929	65	12 110
7	2250	75	13 130
8	2572	85	14 100
9	2893	95	15 000
10	3214	100	15 680
12	3857	130	16 600
14	4500	150	17 400
16	5143	170	18 170
18	5786	200	19 200
20	6200	230	20 170
25	7030	260	21 000
30	7800	(Note 4)	

NOTES:

- 1 The wetted area for a tank is calculated as follows:
 - (a) *Sphere or spheroid* Total exposed surface up to the maximum horizontal diameter or to a height of 8 m, whichever is greater.
 - (b) *Horizontal tank* 75% of the total exposed surface.
 - (c) *Vertical tank* Total exposed surface of the shell within a maximum height of 8 m above grade.
- 2 Interpolate venting capacity for intermediate values of wetted area.
- 3 At 101.5 kPa (absolute) and 15°C.
- 4 If the wetted area exceeds 260 m² but the tank is designed for pressures of 7 kPa or lower, no increase in venting capacity is required. If the wetted area exceeds 260 m² and the tank is designed for pressures higher than 7 kPa, the *total* venting capacity is determined by the following formula:

$$\text{Emergency venting capacity (m}^3\text{/h)} = 220 A^{0.82}$$

where

$$A = \text{wetted area, in square metres.}$$

H3 CAPACITIES OF FREE ORIFICE-TYPE VENTS

The capacity of a vent which consists of a free circular opening, or which is of such a simple construction that it practically is a free circular opening, may be determined from Table H3 for 200 mm diameter or less.

For free circular openings larger than 200 mm in diameter, the following equation is used:

$$\text{Venting capacity (m}^3/\text{h)} = 0.0575 d^2 \sqrt{\Delta p}$$

where

d = diameter of orifice, in millimetres

Δp = difference in pressure between the inside and the outside of the tank, in kPa

TABLE H3
DIAMETERS OF FREE CIRCULAR OPENINGS

Venting capacity m ³ /h	Orifice diameter*, mm					
	Differential pressure, kPa					
	0.25	0.50	0.75	7	17.5	35
50	42	35	32	32	32	32
100	60	50	45	32	32	32
250	93	78	71	41	32	32
500	132	111	100	57	46	38
750	162	136	123	70	56	47
1000	187	157	142	81	65	54
1250	—	175	158	91	72	61
1500	—	192	174	99	79	66
2000	—	—	200	115	91	77
4000	—	—	—	162	129	108
6000	—	—	—	200	158	133
8000	—	—	—	—	182	153
10 000	—	—	—	—	200	172
12 000	—	—	—	—	—	188
14 000	—	—	—	—	—	200

* Interpolate diameter for intermediate values of venting capacity and differential pressure.

APPENDIX I
FIRE EXPOSURE PROTECTION
(Normative)

11 INTRODUCTION

In certain circumstances a tank may need to be protected from the radiant heat emanating from a tank fire nearby. The usual means of protection is to apply cooling water to the tank surfaces.

Computer modelling of heat flux levels from a fire scenario may be used to determine cooling water demand for exposed tanks. Where such computer modelling is not available the procedure outlined in this appendix shall be used.

This Appendix gives a procedure for determining which tanks need cooling water, how much water is required for each tank, and how much water is required in total for the group. It also provides for a basic minimum volume of cooling water, recognizing the possibility that a comparatively large installation could, by a combination of circumstances, fall outside all the other conditions that call for cooling.

The assumptions on which this Appendix is based are as follows:

- (a) Any vertical fixed-roof tank, including those with an internal floating roof, that contains flammable liquid is considered to be a potential tank-on-fire, and therefore to be a potential source of heat radiation to an adjacent tank. A tank containing a combustible liquid which shares a compound with a tank storage of flammable liquid is also considered to be a potential tank-on-fire.
- (b) Radiation levels were established on the basis of a burn-down rate of the liquid level of 300 mm/h.
- (c) The intention is to control the temperature rise of an adjacent tank to a safe level by applying cooling water to that portion of the tank shell or roof that might be exposed to radiant heat.
- (d) For the purpose of calculation, the surface of the tank subject to radiant heat is taken as approximately $\frac{1}{3}$ the tank circumference multiplied by its height plus any corresponding surface of the roof.
- (e) Safe temperature levels were established in relation to the ignition temperature of the type of products being dealt with, i.e. 250°C, to provide a substantial margin below that figure.
- (f) Where the adjacent tank is separated from the tank-on-fire by more than 1.5 times the latter tank's diameter, the calculated temperature rise remains below the safe limit without the need for cooling water.
- (g) The method ignores the potential cooling effect of the latent heat of evaporation of the water, so there is an additional safety factor which is not taken into the calculations.
- (h) Special circumstances on the day, such as wind strength and direction, may require that tanks at distances greater than 1.5 diameters be cooled, or it may be considered desirable to increase the water rate to tanks already covered. It is intended that the uncommitted reserves available in the hydrant system, plus spare cooling water available as the result of reduced upwind cooling needs, would provide the required degree of flexibility in the operation of the system.

- (i) A floating-roof tank is not considered to be a potential tank-on-fire. It may, however, qualify as a tank at risk, and thus require cooling water.
- (j) The formula assumes that the water quantity supplied reaches the tank surface where it is required.

12 CALCULATION OF WATER QUANTITIES

12.1 Identify tanks requiring cooling water

The procedure shall be as follows:

- (a) List every fixed-roof tank which could be used for storing a flammable liquid, or which could contain a combustible liquid and is the same compound as the flammable liquid tank. Each is a potential tank-on-fire and is the basis for the rest of the procedure.
- (b) For each such tank, define a circle concentric with it, and having a radius equal to twice the tank's diameter.
- (c) List all other tanks, including floating-roof tanks, irrespective of the class of contents, which fall wholly or partly within these circles. They need not necessarily be in the same compound. These are the tanks whose separation distances from the potential tank-on-fire are less than 1.5 times its diameter; they are therefore within radiating range, and will need cooling water.
- (d) If no tank qualifies for listing because of separation distances or the use of floating roofs, go to Paragraph 12.3(b).

12.2 Calculate water requirements for each tank

The procedure below shall be followed for each tank listed under Paragraph 12.1(a):

- (a) Determine the value of the S/D ratio, which is—

$$\frac{\text{Separation distance (shell-to-shell)}}{\text{Diameter of tank-on-fire}}$$

- (b) Read from the graph in Figure I1 the value of factor W for the S/D ratio.
- (c) Calculate the cooling water needed for the shell of the particular tank facing the tank-on-fire from the following equation:

$$q_v = dhW$$

where

q_v = flow rate of water supply, in litres per minute, to be applied to that part of the tank exposed to the heat flux

d = diameter of the tank being protected, in metres

h = height (or length) of the tank being protected, in metres

W = factor read from Figure I1, in litres per minute, square metre.

- (d) For any fixed-roof tank within one diameter of the tank-on-fire, add an amount of water equal to $0.25 d^2 W$ to allow for cooling the fire-exposed area of the roof.

NOTES:

- 1 For the purpose of this Paragraph (12.2), the heat-affected area of the tank is taken as being approximately one third of the circumferential area, with sometimes a similar sector of the roof. The location of the area may shift if there are alternative potential radiant heat sources, or because of wind changes.
- 2 A single large water outlet at the centre of a conical roof tank is not considered to be a satisfactory means of applying water.
- 3 The loss due to wind effects when using hoses may be up to 50% of the water applied.

12.3 Determine total cooling water demand for tank shells

The procedure shall be as follows:

- (a) Total the values of qv for each of the tanks listed under Paragraph I2.1(b) and select the largest total.
- (b) Note the total capacity of the installation, select the related factor from Table I1, and multiply this factor by the diameter of the largest tank in the group (either floating-roof or fixed-roof type) that contains flammable liquid. The result is in litres per minute.
- (c) The larger of Items (a) and (b) is the minimum cooling water rate required for the installation.
- (d) Add any wastage factor that is necessitated due to the application method.

NOTE: Wastage might occur from the following:

- (a) Hand-held hoses, which are vulnerable to windage losses and to inaccuracy.
- (b) Fixed monitors, subject to windage losses.
- (c) Fixed piping or spray systems of a design which might apply water to areas of tanks remote from radiation.

TABLE I1
COOLING WATER FACTORS

Total above-ground tank storage, m ³		Minimum cooling water factor
Over	Up to and including	
500	2500	20
2500	5000	30
5000	25 000	40
25 000		50

NOTE: W is the rate of cooling water required, in litres per minute, square metre (L/min.m²) of projected (i.e. silhouette) area of the tank.

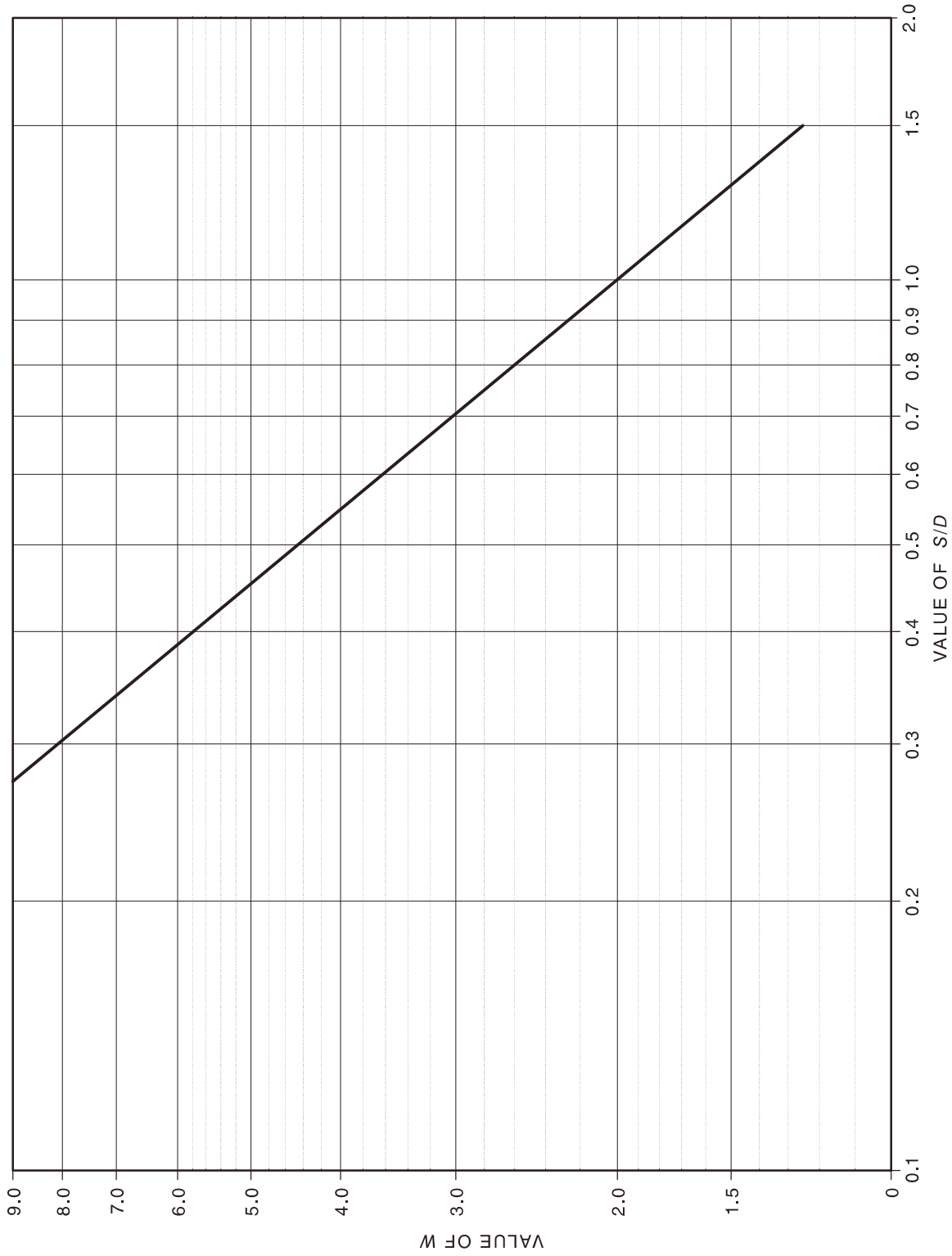

NOTE: W is the rate of cooling water required, in litres per minute, square metre ($L/min.m^2$) of projected (i.e. silhouette) area of the tank

FIGURE I1 DETERMINATION OF W

APPENDIX J
 COMBUSTION CHARACTERISTICS
 (Informative)

Figure J1 provides the vapour conditions of petroleum liquids at various temperatures. Table J1 provides the flammability of air/vapour mixtures in equilibrium with various flammable liquids.

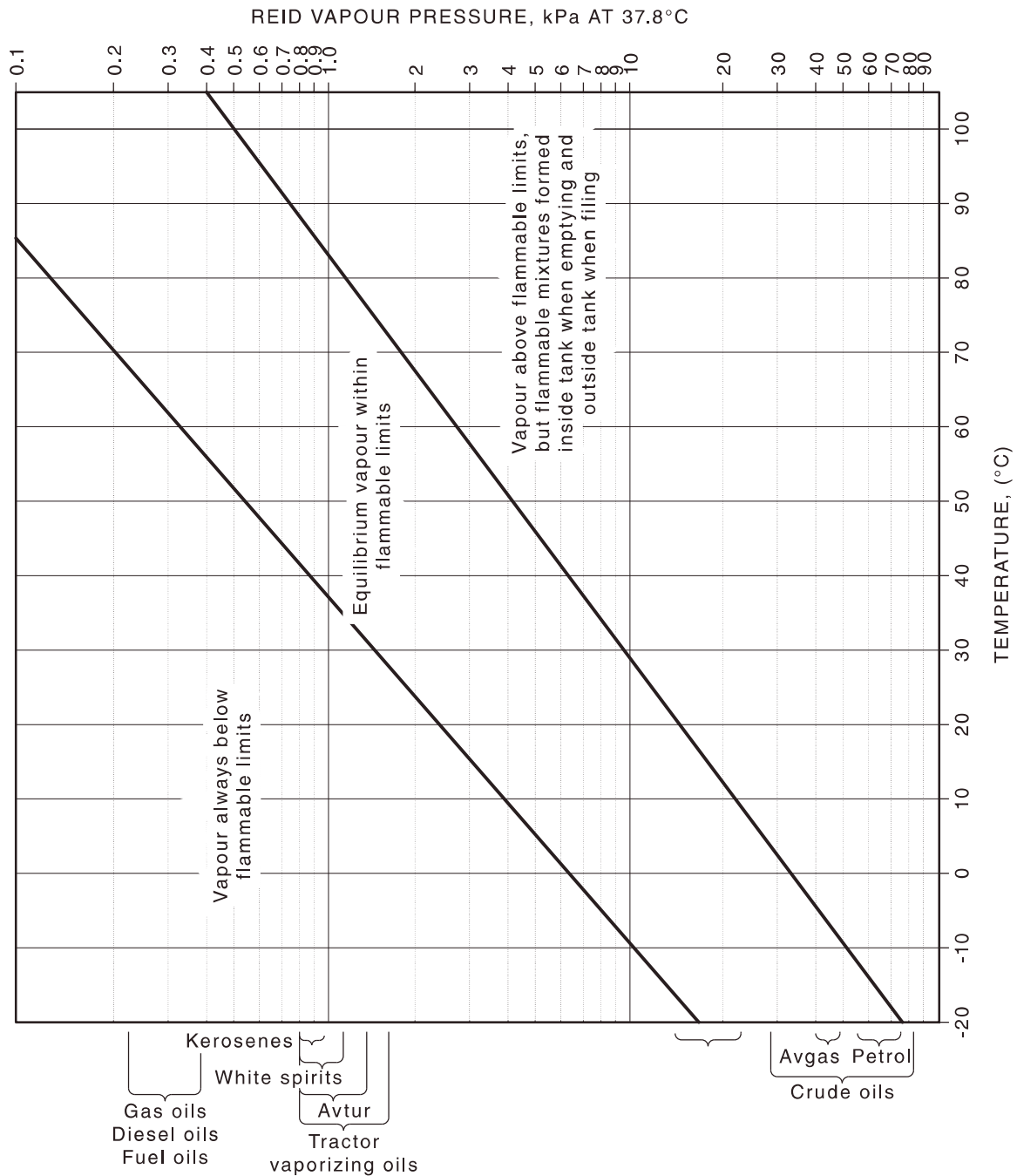

FIGURE J1 VAPOUR CONDITIONS OF PETROLEUM LIQUIDS AT VARIOUS TEMPERATURES

TABLE J1
FLAMMABILITY OF AIR/VAPOUR MIXTURES IN EQUILIBRIUM
WITH VARIOUS FLAMMABLE LIQUIDS

Product	Approximate closed-cup flash point °C	Explosive limit (percentage by volume)		Approximate temperature range in which equilibrium vapour/air mixture is in the explosive range °C
		Lower	Upper	
Crude oil	< -15	1.0	6.0	Below -20 to 5
Jet fuel JP-4	< -15	1.0	7.0	-24 to 26
Kerosene	50	0.7	6.0	38 to 100
Petrol	-43	1.4	7.6	-50 to 0
Hexane solvent	-22	1.2	6.9	-28 to 7
Heptane solvent	-4	1.0	6.0	-5 to 29
VM and P naphtha	10	1.0	6.0	7 to 46
Benzene	-11	1.4	8.0	-14 to 18
Toluene	5	1.3	7.0	4 to 43
Xylene	28	1.0	6.0	25 to 60
Methanol	11	6.0	36.5	7 to 40
Ethanol	13	3.3	19.0	10 to 33
<i>iso</i> -propyl alcohol	15	2.0	12.0	11 to 38
Carbon disulfide	-30	1.0	50.0	-47 to 26
Acetone	-18	2.2	13.0	-23 to 10

Additional data are in AS/NZS 60079.20.1.

APPENDIX K
GAS-FREEING PRECAUTIONS AND PRINCIPLES
(Normative)

K1 INTRODUCTION

This Appendix specifies precautions and principles to be observed when gas-freeing, which are not necessarily exhaustive.

K2 GAS-FREEING WITH AIR

The following requirements shall apply:

- (a) Ventilation shall be forced, so as to shorten the purging time.
- (b) Expelled vapour shall be discharged at as high an elevation as possible.
- (c) Additional care shall be taken in calm weather, when dispersal is minimal, to avoid local concentrations of vapour, e.g. in compounds.
- (d) In the event of any abnormal condition which is potentially hazardous, e.g. a thunderstorm, venting shall be stopped and the tank shall be closed.

K3 GAS-FREEING WITH STEAM

The following requirements shall apply:

- (a) The contents of the tank shall be of a type that can be cleared successfully by steaming, without leaving a combustible residue.
- (b) The temperature of the steam shall be controlled to be at least 50°C below the auto-ignition temperature of any vapour in the tank.
NOTE: The temperature should be as low as possible.
- (c) The velocity of the steam emitted from any hose or nozzle shall be kept as low as possible, and any hose nozzle shall be electrically-bonded to the tank.
- (d) The rate of supply of steam shall be below that which would cause pressure within the tank to build up to any unsafe level.
- (e) For a free flow of steam to be maintained throughout the tank, all manhole covers, valves and blank flanges shall be removed so as to leave open all openings into the tank.

K4 GAS-FREEING WITH WATER

The following requirements and recommendations apply:

- (a) Care shall be exercised to collect all the water used and ensure it is treated and disposed of safely.
- (b) Before a tank is filled with water, it should be ascertained that the tank and its foundations are capable of sustaining the mass of the water.
- (c) The rate of filling or emptying the water should be controlled in relation to the vent capacity to avoid tank damage under pressure or vacuum.
- (d) Static electricity build-up should be avoided by introducing the water at as low a level as possible, keeping the discharge velocity low, and electrically-bonding any hose nozzle to the tank.

- (e) Flooding with water should not be relied upon to remove all vapour, liquid or solid residues.

NOTES:

- 1 The condensate or water will be contaminated with residues of the flammable or combustible liquid, the proportion of which could be relatively high if such liquid is water-miscible. A low flash point liquid that is water-miscible, e.g. ethanol or acetone, may lower the flash point to a temperature at which the condensate is regarded as a flammable liquid, even though it is mainly water.
The condensate or water may require analysis if it is to be disposed of to the sewer. This condensate or water should never be disposed of to stormwater drains.
- 2 It is unlikely that the condensate can be returned to the boiler feed without treatment to remove the liquid residues, even at very low levels of contamination.

K5 GAS-FREEING WITH INERT GAS

In addition to the precautions given in Clause 9.9 and to the requirements of AS/NZS 2865, particular attention shall be given to ensuring that there is sufficient oxygen after any inert gas purging operation. If liquefied gas is used, it shall be fully vaporized before entry into the tank to avoid the build-up of static electricity from a spray of liquid droplets.

NOTES:

- 1 Air purging may be used where steam, water or inert gas are unsuitable. An air mover (air operated Venturi extractor) is the preferred method of air purging, allied with a fresh air down-tube.
- 2 The effectiveness of steaming decreases as the area of the shell increases, because of the loss of steam due to condensation on the shell. The temperature of the shell is therefore an important indicator of effective steam purging, and should achieve a minimum temperature of 70°C and be maintained for a suitable period.
- 3 The atmosphere within a space will not be fit to breathe after purging by inert gas. This method may be used when the effect of steam, water or air on the tank or its contents may be undesirable.
- 4 When gas-free testing is done with combustible gas detectors, the presence of toxic residues may not be indicated.

APPENDIX L

RECOMMENDATIONS FOR BATCH BLENDING OF FLAMMABLE LIQUIDS

(Informative)

L1 INTRODUCTION

This Appendix provides guidance for batch blending operations using flammable liquids within the limits set out below. These recommendations are additional to the requirements of the relevant Sections of this Standard:

- (a) In one or more vessels up to an aggregate capacity of 2500 L.
- (b) Not involving heating, pressurization, or exothermic (self-heating) reactions.
- (c) Not using any dangerous goods of PG I, regardless of their class.

Specialist advice should be sought if the above limits have to be exceeded, if any requirements cannot be complied with, or other methods are to be used.

L2 BUILDING RECOMMENDATIONS

In addition to meeting the relevant requirements of Sections 3 and 4, a building for batch blending should be free-standing and separated from any other building by at least 5 m.

A risk assessment may be required if any other building, work area or electrical installation is within 9 m (see also Appendix E).

NOTE: Most warehouse units do not comply with these recommendations and are not suitable for use as blending areas.

L3 THE BLENDING VESSEL**L3.1 Construction and location of the blending vessel**

The following recommendations apply:

- (a) The vessel should be metal, of substantial construction, and on firm supports.
- (b) The area around the blending vessel should be provided with spillage control, e.g. bunding or a floor sloping to a sump.
- (c) Provision of an access hatch in the lid of the blending vessel will allow ingredients to be added and samples to be withdrawn.
- (d) All pipes below liquid level (especially the bottom outlet) should have a steel isolating valve close to the shell of the vessel.
- (e) The lid should be electrically bonded to the vessel. Cable connections should be permanently attached to the lid with screws, as clamps could become loose or not make proper contact.

NOTE: This is especially important if the lid rests on soft insulating seals. Welding cable or jumper lead cable may be used for bonding.

- (f) The vessel should always remain in the same location unless all safety requirements are met in any location to which it is to be moved. The vessel should never be moved when full.
- (g) Any heating of the vessel requires special precautions and expert advice should be obtained. Gas burners or electric radiators are not suitable.

L3.2 Ventilation of the blending vessel

The following recommendations apply:

- (a) Effective ventilation is necessary to reduce the risk of fire or explosion and to protect workers from exposure to harmful vapours and dusts. Any vapour exhaust system should be connected from the vessel's lid to an extractor fan system by the use of flexible ducting.

NOTE: If there is a strong 'solvent' smell when the vessel's lid is closed, it could indicate that the lid is not sealing properly or that a vapour exhaust system is needed.

- (b) Any extractor fan should at all times maintain a slight negative pressure in the vessel (i.e. draw air in), to prevent vapours from escaping into the blending area. Alternatively, the vessel could be located in a booth with exhaust ventilation similar to a spray booth.
- (c) The exhaust fan should interlock with the lid of the blending vessel, in order to prevent excessive evaporation and to conserve energy. When the vessel lid is opened, the fan should either commence operation or switch from low to high.

L4 CONTROL OF IGNITION SOURCES

Ignition sources are not permitted within the area around the mixing vessel. The following recommendations apply:

- (a) Forklifts need to be authorized for use in the hazardous area, e.g. by a work permit. It may be possible to use a manual pallet lifter to move goods.
- (b) Gas torches are not suitable for shrink-wrapping. Stretch-wrapping should be avoided as the film can cause a build-up of static electricity.
- (c) Tools should be selected in order to avoid or reduce sparks.
- (d) Items of electrical equipment, e.g. stirrers and pumps, that are not of a type suitable for use in a hazardous area, should be replaced with air-driven equipment, with the air compressor located in a safe place.

L5 HANDLING AND BLENDING OF RAW MATERIALS

Liquids should be pumped in through a pipe terminating near the bottom of the blending vessel. If pumping is not possible, the liquid should be poured in slowly and from the lowest practicable height.

NOTE: Splash filling can release large amounts of flammable vapours and cause a build-up of static electricity, which could cause the vapours to explode.

If water or other non-flammable liquid is an ingredient of the blend, this should be filled into the blending vessel first. The flammable liquid should be pumped in, below the liquid level, in order to reduce the amount of vapour released.

Electrically-driven pumps and all associated cabling and switches should be of a certified, explosion-protected type. Hand-operated pumps or pumps driven by compressed air (with the compressor at a location away from ignition sources) are preferred.

Transfer by air or gas pressure is potentially unsafe and should not be used.

Static electricity can build up when pouring powders into the blending vessel, and the powder or vapours can ignite. To prevent this from occurring—

- (a) wet the powder first and add the mixture to the vessel; or
- (b) add the powder using a scoop; or
- (c) reduce the volume and speed of the powder flow.

It is unsafe to use a forklift or hoist to lift a container over the vessel so that its contents can be poured into the mix.

If the vessel can be removed from under the mixer, the mixer drive should be provided with an interlock to prevent its use when it is out of the vessel.

L6 PACKAGE FILLING AREAS

Where packages are gravity-filled, the following recommendations apply:

- (a) Where hoses are connected to the outlet of the mixing vessel, one of the vessel's isolating valves should be self-closing (spring loaded) with a remote release.
- (b) Drums should be filled using a self-closing nozzle. Where splashing could occur, there should be a clear shatterproof shield between the package and the operator.
- (c) An effective vapour removal system should be installed.
- (d) Spillage control should be provided.
- (e) A spillage clean-up kit should be available. See Clause 9.4.2.
- (f) Each package should be closed tightly after filling.
- (g) Filled packages should be removed from the area at least at the end of each shift.

L7 FIRE PROTECTION

The following recommendations apply to fire protection for blending areas and are additional to those specified in Section 11:

- (a) Where the total volume of flammable liquids does not exceed 1000 L, the fire protection requirements given in Table 11.3 for package stores containing up to 10 m³ of flammable liquids apply.
- (b) Where the total volume of flammable liquids exceeds 1000 L, the fire protection requirements given in Table 11.3 for package stores containing up to 100 m³ of flammable liquids apply.
- (c) Any firefighting foam needs to be compatible with the liquids being stored and handled.

L8 CLEANING OF THE MIXING VESSEL

Pressurized water nozzles should not be used unless the vessel is free from flammable vapours, as static electricity could cause an explosion.

The use of flammable, toxic or corrosive cleaning solvents may require further safety precautions. The MSDS/SDS should be consulted or specialist advice sought.

BIBLIOGRAPHY

- AS
1210 Pressure vessels
- 1288 Glass in buildings—Selection and installation
- 1657 Fixed platforms, walkways, stairways and ladders—Design, construction and installation
- 1691 Domestic oil-fired appliances—Installation
- 1726 Geotechnical site investigations
- 1915 Electrical equipment for explosive atmospheres—Battery-operated vehicles
- 2700 Colour Standards for general purposes
- 3846 The handling and transport of dangerous cargoes in port areas
- 4971 Inspection and integrity monitoring of large steel vertical petroleum storage tanks
- 4976 The removal and disposal of underground petroleum storage tanks
- AS/NZS
1680 Interior workplace lighting
1680.1 Part 1: General principles and recommendations
- 2106 Methods for the determination of the flash point of flammable liquids (closed cup) (series)
- AS/NZS ISO
31000 Risk management—Principles and guidelines
- ISO
2592 Determination of flash and fire points—Cleveland open cup method
- IEC
60079 Explosive atmospheres
60079-13 Part 13: Equipment protection by pressurized room ‘p’
- ISO/IEC
80079 Explosive atmospheres (series)
- SAFE WORK AUSTRALIA
Model Code of Practice: Preparation of Safety Data Sheets for Hazardous Chemicals
- API AMERICAN PETROLEUM INSTITUTE
RP 2023 Guide for safe storage and handling of heated petroleum-derived asphalt products and crude-oil residual
- Std 600 Steel Gate Valves—Flanged and Butt-welding Ends, Bolted Bonnets
- Std 620 Design and Construction of Large, Welded, Low-Pressure Storage Tanks
- ASTM
D92 Standard Test Method for Flash and Fire Points by Cleveland Open Cup
- IMO INTERNATIONAL MARITIME ORGANIZATION
IMDG Code International Maritime Dangerous Goods Code
- IP INSTITUTE OF PETROLEUM
36 Determination of flash and fire points—Cleveland open cup method

AMENDMENT CONTROL SHEET

AS 1940:2017

Amendment No. 1 (2019)

REVISED TEXT

SUMMARY: This Amendment applies to the Preface and Clause 5.3.3(f).

Published on 6 August 2019.

Amendment No. 2 (2021)

CORRECTION

SUMMARY: This Amendment applies to Clause 3.6(c) and Figure 4.1(b)(i).

Published on 11 June 2021.

NOTES

NOTES

Standards Australia

Standards Australia develops Australian Standards® and other documents of public benefit and national interest. These Standards are developed through an open process of consultation and consensus, in which all interested parties are invited to participate. Through a Memorandum of Understanding with the Commonwealth Government, Standards Australia is recognized as Australia's peak non-government national standards body.

For further information visit www.standards.org.au

Australian Standards®

Committees of experts from industry, governments, consumers and other relevant sectors prepare Australian Standards. The requirements or recommendations contained in published Standards are a consensus of the views of representative interests and also take account of comments received from other sources. They reflect the latest scientific and industry experience. Australian Standards are kept under continuous review after publication and are updated regularly to take account of changing technology.

International Involvement

Standards Australia is responsible for ensuring the Australian viewpoint is considered in the formulation of International Standards and that the latest international experience is incorporated in national Standards. This role is vital in assisting local industry to compete in international markets. Standards Australia represents Australia at both the International Organization for Standardization (ISO) and the International Electrotechnical Commission (IEC).

For information regarding the development of Standards contact:

Standards Australia Limited
GPO Box 476
Sydney NSW 2001
Phone: 02 9237 6000
Email: mail@standards.org.au
Internet: www.standards.org.au



ISBN 978 1 76035 857 0