

AS/NZS 3500.1:2021



Australian/New Zealand Standard™

# Plumbing and drainage

Part 1: Water services



AS/NZS 3500.1:2021

This Joint Australian/New Zealand Standard™ was prepared by Joint Technical Committee WS-014, Plumbing and Drainage. It was approved on behalf of the Council of Standards Australia on 14 May 2021 and by the New Zealand Standards Approval Board on 7 April 2021.

This Standard was published on 28 May 2021.

The following are represented on Committee WS-014:

- Association of Hydraulic Services Consultants Australia
- Australian Building Codes Board
- Australian Industry Group
- Australian Stainless Steel Development Association
- Backflow Prevention Association of Australia
- Engineers Australia
- Hydraulic Consultants Association Australasia
- International Copper Association Australia
- Master Plumbers Australia and New Zealand
- Master Plumbers, Gasfitters and Drainlayers New Zealand
- Ministry of Business, Innovation and Employment (NZ)
- Plastics Industry Pipe Association of Australia
- Plastics New Zealand
- Plumbers, Gasfitters and Drainlayers Board (NZ)
- Plumbing Distributors Association of New Zealand
- Plumbing Products Industry Group
- The Institute of Plumbing Australia
- Water New Zealand
- Water Services Association of Australia

This Standard was issued in draft form for comment as DR AS/NZS 3500.1:2020.

### **Keeping Standards up-to-date**

Ensure you have the latest versions of our publications and keep up-to-date about Amendments, Rulings, Withdrawals, and new projects by visiting:

[www.standards.org.au](http://www.standards.org.au)

[www.standards.govt.nz](http://www.standards.govt.nz)

ISBN 978 1 76113 345 9

Australian/New Zealand Standard™

# Plumbing and drainage

## Part 1: Water services

First published as AS 3500.1—1990.  
Jointly revised and redesignated as AS/NZS 3500.1:2003.  
Third edition 2018.  
Fourth edition 2021.

© Standards Australia Limited/the Crown in right of New Zealand, administered by the New Zealand Standards Executive 2021

All rights are reserved. No part of this work may be reproduced or copied in any form or by any means, electronic or mechanical, including photocopying, without the written permission of the publisher, unless otherwise permitted under the Copyright Act 1968 (Cth) or the Copyright Act 1994 (New Zealand).

## Preface

This Standard was prepared by the joint Standards Australia/Standards New Zealand Committee WS-014, Plumbing and Drainage, to supersede AS/NZS 3500.1:2018.

The objective of this document is to provide installers with Deemed-to-Satisfy solutions to comply with —

- (a) the National Construction Code (NCC) Volume Three, Plumbing Code of Australia (PCA); and
- (b) the New Zealand Building Code (NZBC), Clause G12 Water Supplies.

A list of all parts in the AS/NZS 3500 series for plumbing and drainage can be found in the Standards Australia and Standards New Zealand online catalogues.

The major changes in this revision are as follows:

- (i) Conformance to individual product standards has been removed. All products used in plumbing and drainage systems in Australia need to comply with the PCA and, in New Zealand, the NZBC, see [Appendix B](#) for further information. Removal of specific product standard conformance requirements avoids inconsistencies and contradictions between this document and the PCA and NZBC.
- (ii) Definitions have been relocated to AS/NZS 3500.0. This was done for consistency across the series.
- (iii) A number of the backflow prevention provisions, which were considered matters of public policy, have been elevated to PCA Part B5 Cross Connection Control. To remove duplication between PCA 2019 and AS/NZS 3500.1, the provisions relating to cross-connection hazards and the corresponding hazard rating have been removed. This also avoids inconsistencies between the cross-connection hazards and the corresponding hazard rating in this document and in NZBC Acceptable Solution G12/AS1. Consequently, [Appendix F](#) has been deleted, and all remaining backflow provisions have been consolidated in [Section 4](#).
- (iv) Jointing requirements for plastics pipes have been clarified and expanded to allow different methods.
- (v) Changes to the requirements for the marking of pipes in commercial buildings to assist in the better identification of pipework and avoid cross connections.
- (vi) Changes to the requirements for the installation of water services located in metal-framed walls to bring the provisions in line with those of the National Association of Steel-framed Housing.
- (vii) [Clause 5.4](#) relating to bushfire zones has been removed in anticipation of requirements relating to bushfire prone areas being elevated to the PCA.
- (viii) [Section 12](#) relating to special connections for specific fixtures has been removed. With backflow requirements being moved to the PCA, listing these few examples would be inappropriate. The WaterMark specifications for the product would identify what backflow devices were required.

The terms “normative” and “informative” are used in Standards to define the application of the appendices to which they apply. A “normative” appendix is an integral part of a Standard, whereas an “informative” appendix is only for information and guidance.

Notes or footnotes to tables or figures that are expressed in mandatory terms are deemed to be requirements of this document.

Notes to clauses in this document are informative only and do not include requirements.

*This document includes a commentary on some of the clauses. The commentary directly follows the relevant clause, is designated by "C" preceding the clause number and is printed in italics in a box. The commentary is for information and guidance and does not form part of the document.*

# Contents

<b>Preface</b> .....	<b>ii</b>
<b>Section 1 Scope and general</b> .....	<b>1</b>
1.1 Scope.....	1
1.2 Application.....	1
1.2.1 Australia.....	1
1.2.2 New Zealand.....	1
1.3 Normative references.....	1
1.4 Terms and definitions.....	2
1.5 Abbreviations.....	2
1.6 Equivalent pipe sizes.....	2
1.7 Facilities for people with disabilities.....	2
1.8 Termite management.....	3
<b>Section 2 Materials and products</b> .....	<b>4</b>
2.1 Scope of section.....	4
2.2 General.....	4
2.3 Pipes and fittings — General limitations.....	4
2.4 Metallic pipes and fittings.....	4
2.4.1 Cold water services.....	4
2.4.2 Firefighting water services.....	5
2.4.3 Limitations.....	5
2.5 Plastics pipes and fittings.....	6
2.5.1 Cold water service.....	6
2.5.2 Firefighting water services.....	7
2.5.3 Limitations.....	7
2.6 Safe-tray materials.....	7
2.7 Joints.....	8
2.7.1 Flanged joints.....	8
2.7.2 Elastomeric seals.....	8
2.7.3 Silver brazing alloy.....	8
2.7.4 Solvent cement and priming fluid.....	9
2.7.5 Filler rods for stainless steel joints.....	9
2.8 Miscellaneous materials.....	9
2.8.1 Concrete mix.....	9
2.8.2 Cement mortar.....	9
2.8.3 Water for concrete and mortar.....	9
2.8.4 Timber.....	10
2.8.5 External protective coatings.....	10
2.8.6 Marking tape.....	10
<b>Section 3 Sizing of water services</b> .....	<b>11</b>
3.1 Scope of section.....	11
3.2 Flow requirements.....	11
3.2.1 Flow rates.....	11
3.2.2 Loading units.....	11
3.2.3 Probable simultaneous demand.....	11
3.2.4 Probable simultaneous flow rates.....	13
3.3 Pressure requirements.....	14
3.3.1 Available pressure.....	14
3.3.2 Pressure at outlets.....	14
3.3.3 Pressure losses.....	14
3.3.4 Maximum pressure within buildings.....	14
3.3.5 Availability of water supply.....	14
3.4 Velocity requirements.....	14
3.5 Pipe size limitations.....	14
3.5.1 Water service.....	14

3.5.2	Branch offtakes.....	15
<b>Section 4</b>	<b>Cross-connection control and backflow prevention.....</b>	<b>16</b>
4.1	Scope of section.....	16
4.2	Protection of water supplies.....	16
4.2.1	Design.....	16
4.2.2	Protection against contaminants.....	16
4.2.3	Combined tanks.....	16
4.2.4	Alternative water supplies.....	16
4.2.5	Integral backflow prevention.....	16
4.3	Cross-connection hazard rating.....	16
4.4	Provision of backflow prevention devices.....	17
4.4.1	General.....	17
4.4.2	Type of backflow protection.....	20
4.4.3	Hose taps.....	20
4.4.4	Additional backflow protection.....	20
4.4.5	Water downstream of backflow prevention device.....	20
4.4.6	Commissioning.....	20
4.4.7	Heated water systems.....	21
4.5	Suitability of devices for hazards.....	21
4.6	Installation of backflow prevention devices.....	21
4.6.1	General installation requirements.....	21
4.6.2	Location of devices.....	22
4.6.3	Specific installation requirements for testable and non-testable devices.....	22
<b>Section 5</b>	<b>Installation of cold water services.....</b>	<b>26</b>
5.1	Scope of section.....	26
5.2	Installation of pipes and fittings.....	26
5.2.1	Copper pipes and fittings.....	26
5.2.2	Plastics pipes and fittings.....	26
5.3	Proximity to other services.....	26
5.3.1	General.....	26
5.3.2	Above-ground services.....	26
5.3.3	Below-ground services.....	27
5.3.4	Crossover of underground services.....	29
5.3.5	Clearance from underground obstructions.....	29
5.4	Isolating valves.....	29
5.4.1	General.....	29
5.4.2	Location.....	29
5.4.3	On fire services.....	30
5.4.4	Multiple dwellings.....	30
5.4.5	Maintenance.....	30
5.5	Location of piping.....	30
5.5.1	Location.....	30
5.5.2	Concealed piping.....	31
5.5.3	Chases, ducts or conduits.....	36
5.5.4	Under concrete slabs.....	36
5.6	Methods of jointing.....	37
5.6.1	General.....	37
5.6.2	Threading.....	37
5.6.3	Bolted gland and Gibault-type joints.....	37
5.6.4	Jointing of copper and copper alloy pipes.....	37
5.6.5	Compression joints.....	37
5.6.6	Flanged joints.....	38
5.6.7	Roll-grooved joints.....	38
5.6.8	Silver brazing.....	38
5.6.9	Jointing of plastics pipes.....	38
5.6.10	Jointing of stainless-steel pipe and fittings.....	39
5.6.11	Jointing of dissimilar metallic pipes and fittings below ground.....	40

5.7	Support and fixing above ground	40
5.7.1	General	40
5.7.2	Brackets, clips and hangers	40
5.7.3	Limitations of pipe supports	40
5.7.4	Spacing	40
5.7.5	Securing of pipes and fittings	41
5.8	Standpipes	41
5.9	Anchorage below ground	42
5.9.1	General	42
5.9.2	Location of thrust blocks	42
5.9.3	Construction of thrust blocks	44
5.10	Depth of cover	44
5.11	Bedding and backfill	44
5.12	Installation in contaminated areas	45
5.13	Corrosive areas	45
5.14	Pipes in water-charged or filled ground	46
5.15	Open channels or watercourses	46
5.16	Private easements	46
5.16.1	Proximity of water services	46
5.16.2	Depth of piping	46
5.17	Dry services	46
5.18	Protection against freezing	46
5.18.1	General	46
5.18.2	Piping located outside buildings	46
5.18.3	Pipes located on metal roofs	47
5.18.4	Pipes located inside buildings	47
5.18.5	Insulation of piping	48
5.19	Identification of piping	48
5.20	Temperature control devices	48
5.21	Australian bushfire prone areas	49
<b>Section 6</b>	<b>Fire services</b>	<b>50</b>
6.1	Scope of section	50
6.2	Materials and products	50
6.3	Installation	50
6.4	Water storage tanks	50
6.5	Identification	50
<b>Section 7</b>	<b>Irrigation and lawn watering systems</b>	<b>51</b>
7.1	Scope of section	51
7.2	System types	51
7.3	Backflow protection requirements	56
7.4	Materials	56
<b>Section 8</b>	<b>Water storage tanks</b>	<b>57</b>
8.1	Scope of section	57
8.2	Purpose of tanks	57
8.2.1	General	57
8.2.2	Limitations on use	57
8.3	Design and installation requirements	57
8.3.1	General	57
8.3.2	Capacity of storage tanks — Measurement	58
8.3.3	Access	58
8.3.4	Placement of tank	58
8.4	Tank design	58
8.4.1	General	58
8.4.2	Internal corrosion protection	59
8.4.3	Tank cover	59
8.4.4	Tank overflow	59
8.5	Inlet piping	64

8.5.1	Connections.....	64
8.5.2	Stop valve.....	64
8.6	Outlet piping.....	64
8.6.1	Connections.....	64
8.6.2	Service outlets.....	64
8.7	Sludge valves.....	64
8.8	Safe-tray.....	64
8.8.1	General.....	64
8.8.2	Safe-tray construction.....	64
8.8.3	Overflow.....	65
8.9	Marking of tanks.....	65
<b>Section 9</b>	<b>Non-drinking water services.....</b>	<b>66</b>
9.1	Scope of section.....	66
9.2	Materials and products.....	66
9.2.1	General.....	66
9.2.2	Water meters.....	66
9.3	Installation requirements.....	67
9.3.1	Installation.....	67
9.3.2	Proximity to other services.....	67
9.4	Cross-connection control.....	67
9.5	Temporary bypass.....	67
9.6	Identification of non-drinking water services.....	68
9.6.1	Colour of non-drinking water pipework.....	68
9.6.2	Marking of non-drinking water pipework.....	68
9.6.3	Identification of buried non-drinking water services.....	69
9.6.4	Installation of underground marking tape.....	69
9.7	Non-drinking water outlets.....	69
9.7.1	External non-drinking hose tap outlets.....	69
9.7.2	Identification of all non-drinking water outlets.....	70
9.8	Testing and commissioning a non-drinking water service.....	70
9.8.1	Flushing and testing.....	70
9.8.2	Commissioning a non-drinking water service.....	70
<b>Section 10</b>	<b>Treated greywater services.....</b>	<b>72</b>
10.1	Scope of section.....	72
10.2	Materials and products.....	72
10.3	Cross-connection control.....	72
10.4	Installation.....	72
<b>Section 11</b>	<b>Water for sanitary flushing.....</b>	<b>73</b>
11.1	Scope of section.....	73
11.2	General.....	73
11.3	Water closet.....	73
11.4	Urinals.....	73
11.5	Installation of cisterns.....	73
11.5.1	General.....	73
11.5.2	Urinal type cisterns.....	73
11.5.3	Manually operated cisterns.....	74
11.5.4	Water closet pan and slop hopper pan type cisterns.....	74
11.6	Flush valves supplied from break tanks.....	74
11.6.1	General.....	74
11.6.2	Capacity.....	74
11.6.3	Operating head.....	74
11.6.4	Pipe size guide.....	74
11.6.5	Urinal flush valves.....	75
11.7	Flush pipes and water flow distribution.....	75
11.8	Pressure ratio valves.....	75
11.8.1	General.....	75
11.8.2	Requirement for pressure gauges.....	75

11.9	Flush valves connected to the drinking water service	77
11.9.1	General	77
11.9.2	Compatibility	77
11.9.3	Pipe size	77
11.9.4	Protection	77
11.9.5	Location	77
11.9.6	Pressure and velocity limitations	77
11.9.7	Branch service pipe	77
<b>Section 12</b>	<b>Pumps</b>	<b>78</b>
12.1	Scope of section	78
12.2	General	78
12.3	Control of pumps	78
12.4	Installation of pumps	78
12.5	Booster pumps	78
<b>Section 13</b>	<b>Water requirements for haemodialysis machines</b>	<b>79</b>
13.1	Scope of section	79
13.2	Connection to the water service	79
13.3	Maintenance of flow rate	79
13.4	Water meters	79
<b>Section 14</b>	<b>Property water meters</b>	<b>80</b>
14.1	Scope of section	80
14.2	Location of water meters	80
14.3	Installation inside buildings	81
14.4	Installation below ground	81
14.5	Protection from mechanical damage	81
14.6	Frost protection	81
<b>Section 15</b>	<b>Installation of water supply system from rainwater tanks</b>	<b>82</b>
15.1	Scope of section	82
15.2	Pipes, valves and fittings	82
15.3	Installation	82
15.3.1	General	82
15.3.2	Additional marking and signage of pipework and outlets	82
15.3.3	Connection between service pipes	83
15.4	Testing and commissioning a rainwater system	84
15.4.1	Flushing and testing	84
15.4.2	Commissioning a rainwater system	85
<b>Section 16</b>	<b>Multi-unit developments</b>	<b>86</b>
16.1	Scope of section	86
16.2	Methods of design and installation	86
16.3	Division of development	86
16.4	Ring mains and flushing points	86
16.5	Fire services	86
<b>Section 17</b>	<b>Testing and commissioning</b>	<b>87</b>
17.1	Scope of section	87
17.2	Flushing	87
17.3	Testing	87
17.3.1	Hydrostatic test	87
17.3.2	Storage tanks (except rainwater tanks)	87
17.4	Cleaning and disinfection of drinking water storage tanks	87
17.5	Disinfection of water services	87
17.6	Commissioning	87
<b>Appendix A</b>	<b>(normative) Equivalent pipe sizes</b>	<b>88</b>
<b>Appendix B</b>	<b>(informative) Demonstrating products and materials are fit for purpose</b>	<b>91</b>
<b>Appendix C</b>	<b>(informative) Sizing method for supply piping for dwellings</b>	<b>93</b>

<b>Appendix D</b> (informative) <b>Sizing of piping for dwellings</b> .....	<b>102</b>
<b>Appendix E</b> (informative) <b>Examples of potential cross-connections</b> .....	<b>105</b>
<b>Appendix F</b> (informative) <b>Storage tanks — Inflow and overflow</b> .....	<b>108</b>
<b>Appendix G</b> (normative) <b>Cleaning and disinfection of storage tanks</b> .....	<b>111</b>
<b>Appendix H</b> (normative) <b>Disinfection of water services</b> .....	<b>113</b>
<b>Bibliography</b> .....	<b>115</b>

## NOTES

# Australian/New Zealand Standard

## Plumbing and drainage

### Part 1: Water services

#### Section 1 Scope and general

##### 1.1 Scope

This document specifies requirements for the design, installation and commissioning of cold water services from a point of connection to the points of discharge, and for non-drinking water from a point of connection to the points of discharge. It applies to new installations as well as alterations, additions and repairs to existing installations.

Illustrations used in this Standard are diagrammatic only and have been chosen without prejudice.

NOTE 1 Refer to AS/NZS 3500.4 for requirements for heated water services.

NOTE 2 See [Figure 14.2](#) for typical installation of a property service and water service.

##### 1.2 Application

###### 1.2.1 Australia

This document shall be read in conjunction with the National Construction Code (NCC), primarily Volume Three, the Plumbing Code of Australia (PCA).

Where alternative Australian or New Zealand Standards are referenced (e.g. AS 1345) the Australian Standard shall be used for Australia.

###### 1.2.2 New Zealand

This document shall be read in conjunction with the New Zealand Building Code. This document may be used to demonstrate compliance with the New Zealand Building Code, Clause G12 Water Supplies.

Where alternative New Zealand Standards are referenced (e.g. NZS 5807), the New Zealand Standard shall be used for New Zealand.

##### 1.3 Normative references

The following documents are referred to in the text in such a way that some or all of their content constitutes requirements of this document.

NOTE Documents referenced for informative purposes are listed in the Bibliography.

AS 1345, *Identification of the contents of pipes, conduits and ducts*

AS 2419.1, *Fire hydrant installations, Part 1: System design, installation and commissioning*

AS 2845.2, *Water supply — Backflow prevention devices, Part 2: Registered air gaps and registered break tanks*

AS 4809, *Copper pipe and fittings — Installation and commissioning*

AS/NZS 2032, *Installation of PVC pipe systems*

AS/NZS 2033, *Installation of polyethylene pipe systems*

AS/NZS 2648.1, *Underground marking tape, Part 1: Non-detectable tape*

AS/NZS 2845.3, *Water supply — Backflow prevention devices, Part 3: Field testing and maintenance of testable devices*

AS/NZS 3500.0, *Plumbing and drainage, Part 0: Glossary*

AS/NZS 3500.4, *Plumbing and drainage, Part 4: Heated water services*

AS/NZS 3690, *Installation of ABS pipe systems*

NZS 4219, *Seismic performance of engineering systems in buildings*

NZS 5807, *Code of practice for industrial identification by colour, wording or other coding*

ANSI AWWA C651, *Disinfecting Water Mains*

EN 10312, *Welded stainless steel tubes for the conveyance of aqueous liquids including water for human consumption — Technical delivery conditions*

ASME B36.19M, *Stainless Steel Pipe*

WSAA WSA 03, *Water supply code of Australia*

New Zealand Building Code (NZBC), *Acceptable Solution G12/AS1*

## 1.4 Terms and definitions

For the purposes of this document, the definitions given in AS/NZS 3500.0 apply.

## 1.5 Abbreviations

The following plastics abbreviations are used in this document.

ABS	Acrylonitrile butadiene styrene
PB	Polybutylene
PE	Polyethylene
PE-X	Cross-linked polyethylene
PP	Polypropylene
PVC-C	Chlorinated polyvinyl chloride
PVC-M	Modified polyvinyl chloride
PVC-O	Oriented polyvinyl chloride
PVC-U	Unplasticized polyvinyl chloride

## 1.6 Equivalent pipe sizes

Where the nominal size of a pipe is specified in this document, an equivalent pipe size, appropriate to the material being used, shall be selected from [Appendix A](#).

## 1.7 Facilities for people with disabilities

Requirements for the installation of sanitary facilities for people with disabilities are specified in:

- (a) For Australia — the National Construction Code (NCC).

- (b) For New Zealand — the New Zealand Building Code (NZBC), Clause G1 Personal Hygiene.

### 1.8 Termite management

This document does not cover termite barriers and construction techniques to impede and discourage termite attack in buildings.

**C1.8** *Within Australia, termites have a wide geographic distribution and can attack cellulose products, including timber, in service in buildings.*

*AS 3660.1 and the NCC contain information on protection of new buildings from subterranean termites.*

*Where a building has been treated against termite attack, it is essential that care be exercised during installation of plumbing services so that both physical and chemical termite barriers are not compromised.*

## Section 2 Materials and products

### 2.1 Scope of section

This section specifies requirements for materials and products used in cold water services.

### 2.2 General

Materials and products used in a cold water service shall be selected to ensure they are fit for their intended purpose.

NOTE 1 See [Appendix B](#) for more information.

In New Zealand, materials and products in contact with water that are intended for human consumption, food preparation, utensil washing, personal hygiene or oral hygiene shall conform to AS/NZS 4020. Linings and coatings shall conform to AS/NZS 4020, at a surface area to volume ratio not greater than that applicable to the installation.

NOTE 2 In New Zealand, the requirements for materials and products are contained in NZBC Clauses B2 Durability and G13 Foul Water.

NOTE 3 In Australia, the requirements for materials and products in contact with drinking water are contained in the Plumbing Code of Australia.

### 2.3 Pipes and fittings — General limitations

The following limitations shall apply to the use of pipes and fittings for water services:

- (a) Pipes and fittings —
  - (i) up to and including DN 100 shall have a maximum allowable operating pressure (MAOP) of at least 1.2 MPa at 20 °C; and
  - (ii) where larger than DN 100 shall be selected to satisfy design criteria for the system.
- (b) Bends in pipes shall be free from wrinkling and flattening.
- (c) Semi-flexible connectors and braided flexible hoses shall be used only above surface level and in accessible locations.
- (d) Pipes and fittings shall be protected from external heat sources that limit the service life of the pipes.
- (e) Soft solder jointing shall not be used for new joints.

NOTE For the repair of existing joints, soft solder should not contain more than 0.1 % lead by weight.

### 2.4 Metallic pipes and fittings

#### 2.4.1 Cold water services

Where metallic pipes and fittings are used in a cold water service, they shall be of the following material types:

- (a) Cast iron fittings (grey cast iron).
- (b) Copper pipes and fittings.
- (c) Copper alloy fittings.
- (d) Ductile iron pipes and fittings.

- (e) Stainless steel (SS) pipes and fittings.

NOTE 1 See [Appendix B](#) for information on demonstrating products and materials are fit for purpose.

NOTE 2 The following Standards contain additional information:

- (a) AS 3795 — copper alloy tubes.
- (b) AS 1432 — copper tubes.
- (c) NZS 3501 — copper tubes.
- (d) AS/NZS 2280 — ductile iron pipes and fittings.
- (e) AS 5200.053 — stainless steel pipes and tubes.

#### 2.4.2 Firefighting water services

Where metallic pipes and fittings are used in firefighting water services, they shall be of the following material types:

- (a) Cast iron fittings (grey cast iron).
- (b) Copper pipes and fittings.
- (c) Copper alloy fittings.
- (d) Ductile iron pipes and fittings.
- (e) Galvanized steel pipes and fittings.
- (f) Stainless steel (SS) pipes and fittings.

#### 2.4.3 Limitations

Metallic pipes and fittings shall conform to the following:

- (a) Ductile iron pipes and fittings shall be lined and provided with an outer protective coating.
- (b) Cast iron pipes and fittings shall be lined with cement mortar and provided with an outer protective coating.
- (c) Galvanized pipes and fittings shall be used only in non-drinking water systems that are installed above ground. The internal and external galvanizing coating shall be a minimum of 300 g/m<sup>2</sup> hot-dipped galvanizing.

NOTE 1 The risk of rapid corrosion should be considered when selecting galvanized steel pipes for any application.

Where galvanized steel fire hydrant or booster riser pipes are to be buried below ground in accordance with AS 2419.1, the pipes shall be of heavy thickness up to and including DN 80 and not less than medium thickness over DN 80.

The maximum length of fire hydrant or booster riser pipe below ground shall be 1.5 m. The buried section of pipe shall be protected against corrosion by continuous wrapping in petrolatum tape.

NOTE 2 See [Section 6](#) for information on fire services.

NOTE 3 Refer to ANSI/AWWA C217 for information on petrolatum and petroleum wax tape.

- (d) Fittings used to join stainless steel (SS) pipes shall be dezincification resistant (DR) copper alloy or stainless steel.

NOTE 4 Refer to AS 3688 for information on metallic fittings and end connectors.

- (e) For corrosion resistance, the composition of stainless-steel pipes, tubes and fittings shall have a minimum pitting resistance equivalent number (PREN) of 22.

NOTE 5 The PREN may be calculated as follows:

$$\text{PREN} = \% \text{Cr} + (3.3 \times \% \text{Mo}) + (16 \times \% \text{N}).$$

NOTE 6 A PREN of 18 is approximately equivalent to Grade 304, and a PREN of 23 is approximately equivalent to Grade 316.

- (f) Copper pipes shall only be of Type A, B or C.

NOTE 7 Refer to AS 1432 for information on copper types (A, B or C).

NOTE 8 Copper pipes manufactured in accordance with NZS 3501 are also suitable for use in New Zealand.

## 2.5 Plastics pipes and fittings

### 2.5.1 Cold water service

Where plastic pipes and fittings are used in a cold water service, they shall be of the following material types:

- (a) Acrylonitrile butadiene styrene (ABS).
- (b) Polybutylene (PB) pipes and fittings.
- (c) Polyethylene (PE) pipes and fittings.
- (d) Cross-linked polyethylene (PE-X) pipes and fittings.
- (e) Multilayer pipes (MLP) and fittings.
- (f) Unplasticized polyvinyl chloride (PVC-U) pipes and fittings.
- (g) Modified polyvinyl chloride (PVC-M) pipes and fittings.
- (h) Oriented polyvinyl chloride (PVC-O) pipes and fittings.
- (i) Polypropylene (PP) pipes and fittings.

NOTE 1 See [Appendix B](#) for information on demonstrating products and materials are fit for purpose.

NOTE 2 The following Standards contain additional information:

- (a) AS/NZS 3518 — Acrylonitrile butadiene styrene (ABS) compounds, pipes and fittings.
- (b) AS/NZS 2642.2 or AS 5082.1 — hot and cold water polybutylene (PB) pipes.
- (c) AS/NZS 2642.3 or AS 5082.2 — mechanical jointing fittings for use in PB piping systems.
- (d) AS/NZS 4129 — Polyethylene (PE) fittings and AS/NZS 4130 — PE pipes for pressure applications.
- (e) AS/NZS 2492 — Cross-linked polyethylene (PE-X) pipes for pressure applications.
- (f) AS/NZS 2537 (Parts 1, 2 and 5) — mechanical jointing fittings for use with PE-X pipes.
- (g) AS 4176 (Parts 1, 2, 3, 5 and 7) — multilayer pipes (MLP) and fittings for pressure applications.
- (h) AS/NZS 1477 — Unplasticized polyvinyl chloride (PVC-U) pipes and fittings.
- (i) AS/NZS 4765 — Modified polyvinyl chloride (PVC-M) pipes and fittings.
- (j) AS/NZS 4441 — Oriented polyvinyl chloride (PVC-O) pipes and fittings.

- (k) ISO 15874 (all parts) — Polypropylene (PP) pipes and fittings.
- (l) ASTM D2846 — Chlorinated polyvinyl chloride (PVC-C) pipes and fittings.

### 2.5.2 Firefighting water services

Where plastic pipes and fittings are used in firefighting water services, they shall be of the following material types:

- (a) Chlorinated polyvinyl chloride (PVC-C) pipes and fittings.
- (b) Unplasticized polyvinyl chloride (PVC-U) pipes and fittings.
- (c) Modified polyvinyl chloride (PVC-M) pipes and fittings.
- (d) Oriented polyvinyl chloride (PVC-O) pipes and fittings.
- (e) Polyethylene (PE) pipes and fittings.

### 2.5.3 Limitations

Plastics pipes and fittings shall conform to the following:

- (a) Where plastics pipes and fittings are subject to direct sunlight, the following apply to the installation:
  - (i) Coloured, striped and jacketed pipes and fittings shall be protected, see [Clause 2.5.3\(b\)](#) Notes 1 to 3. (Solid black PE pipes and fittings are not required to be protected.)
  - (ii) ABS is not required to be protected.
  - (iii) Coloured, striped and jacketed PE-X pipes and fittings shall be protected. (Solid black PE-X pressure pipe is not required to be protected.)
  - (iv) Plastics pipes of other materials including PVC, PB, PP and MLP shall be protected, see [Clause 2.5.3\(b\)](#) Note 2.
- (b) Plastics pipes and fittings shall not be used to support valves, meters or associated pipes and fittings.
 

NOTE 1 Examples of protection include sleeving with metal or plastics pipes or conduit or lagging.

NOTE 2 Refer to AS/NZS 2032 for the use, handling and transportation and storage requirements for PVC pipes and fittings.

NOTE 3 Refer to AS/NZS 2033 for the transport, handling and storage requirements for PE pipes and fittings.
- (c) The minimum pressure rating for plastics pipes used in a cold water service is PN 12.
- (d) The minimum pressure rating for plastics pipes used in a firefighting water service is PN 16.
- (e) The minimum pressure rating for plastics pipes used in a fire sprinkler system is PN 12 for above ground and PN 16 for below ground.

## 2.6 Safe-tray materials

Safe-trays shall be —

- (a) fabricated from 0.60 mm thick galvanized steel sheet having a minimal nominal zinc coating mass of 275 g/m<sup>2</sup>; or

- (b) made from other materials with corrosion properties not inferior to the requirements of (a).

## 2.7 Joints

### 2.7.1 Flanged joints

Where flanged joints are used, they shall be of the following material types:

- (a) PVC-U.
- (b) Polyethylene.
- (c) Ductile iron, cast iron and grey cast iron.
- (d) Copper alloy and composite.
- (e) Steel.

NOTE The following Standards contain additional information:

- (a) AS 2129 — flanges for metal pipes, valves and fittings.
- (b) AS/NZS 4331.1 — steel flanges.
- (c) AS/NZS 4331.2 — cast iron flanges.
- (d) AS/NZS 4331.3 — copper and copper alloy composite flanges.
- (e) AS/NZS 4087 — metallic flanges for waterworks purposes.
- (f) AS/NZS 1477 — PVC pipes and fittings for pressure applications.
- (g) AS/NZS 2280 — ductile iron pipes and fittings.
- (h) AS/NZS 2544 — grey iron pressure fittings.

### 2.7.2 Elastomeric seals

Where an elastomeric seal gasket is provided in the line or in a fitting, it shall not be replaced with mastic or sealant compounds.

NOTE Refer to AS 1646 for information on elastomeric seals for waterworks purposes.

### 2.7.3 Silver brazing alloy

#### 2.7.3.1 Copper and copper alloys

Silver brazing alloys and copper-phosphorus brazing alloys for capillary jointing of copper and copper alloy pipes and fittings shall contain a minimum of 1.8 % silver and a maximum of 0.05 % cadmium.

NOTE Refer to AS/NZS 1167.1 for information on filler metal for brazing and braze welding.

#### 2.7.3.2 Stainless steels

Silver brazing alloys for capillary jointing of stainless-steel pipes and fittings shall contain a minimum of 38 % silver and a maximum of 0.05 % cadmium.

NOTE Refer to AS/NZS 1167.1 for information on filler metal for brazing and braze welding.

### 2.7.4 Solvent cement and priming fluid

Solvent cement and priming fluid shall be used for the solvent cement jointing of PVC-U and PVC-M pipes and fittings. Solvent cement shall not be used without priming fluid.

NOTE 1 The colour of the priming fluid should be different from the colour of the solvent cement and the pipe to which it is applied. Generally, the priming fluid is pink, and the solvent cement is generally —

- (a) for Type P PVC, green (Australia) or blue or gold (New Zealand);
- (b) for Type N PVC, blue (Australia) or clear (New Zealand);
- (c) for Type P ABS, grey; and
- (d) for Type G, clear.

NOTE 2 See [Clause 5.6.9](#) for plastics pipes jointing requirements.

### 2.7.5 Filler rods for stainless steel joints

Welded joints in stainless steel pipework larger than DN 25 shall be made using filler rods of low carbon stainless steel not greater than 2 mm in diameter.

NOTE Refer to AS/NZS 1167.2 for information on filler metals for welding.

## 2.8 Miscellaneous materials

### 2.8.1 Concrete mix

Ready-mixed concrete shall have a minimum characteristic compressive strength of 20 MPa. Site-mixed concrete shall consist of cement, fine aggregate and coarse aggregate, all measured by volume with sufficient water added to make the mix workable. Site-mixed concrete shall have a minimum characteristic compressive strength of 20 MPa.

NOTE 1 Refer to AS 1379 for information on the specification and supply of concrete.

NOTE 2 The compressive strength of concrete is defined in —

- (a) AS 3600 in Australia; and
- (b) NZS 3109 and NZS 3124 in New Zealand.

NOTE 3 Refer to AS/NZS 4671 for information on steel reinforcing materials.

### 2.8.2 Cement mortar

Cement mortar shall consist of one part cement and two parts of fine aggregate, all measured by volume and properly mixed with the minimum amount of water necessary to render the mix workable. However, for bedding pipes, a mixture consisting of one part cement to four parts fine aggregate may be used.

Cement mortar that has been mixed and left standing for more than 1 h shall not be used.

NOTE Refer to AS 1478.1 for information on chemical admixtures, mortar and grout.

### 2.8.3 Water for concrete and mortar

Water used for mixing concrete and cement mortar shall be free from impurities that are harmful to the mixture, the reinforcement, or any other items embedded within the concrete or mortar.

## 2.8.4 Timber

### 2.8.4.1 Timber in Australia

In Australia, timber exposed to the weather shall be of Durability Class 2 or treated with an appropriate preservative. Timber in contact with the ground shall be of Durability Class 1.

NOTE 1 Refer to AS/NZS 2878 for information on timber classification into strength groups.

NOTE 2 Refer to AS/NZS 1604 for information on preservative treatment of sawn and round timber.

### 2.8.4.2 Timber in New Zealand

In New Zealand, timber exposed to the weather shall be treated to H3 (CCA). Timber in contact with the ground shall be treated to H4 (CCA).

NOTE 1 Refer to NZS 3631 for information on timber grading rules.

NOTE 2 Refer to NZS 3640 for information on chemical preservation of round and sawn timber.

## 2.8.5 External protective coatings

External coatings used for the protection of pipes and fittings buried in corrosive areas shall —

- (a) be impervious to the passage of moisture;
- (b) be resistant to the corrosive environment;
- (c) be resistant to abrasion by the surrounding fill; and
- (d) not contain any material that may cause corrosion to the underlying pipes or fittings.

NOTE Polyethylene sleeving used to protect underground pipes and fittings may require additional protection if installed in rock or stony ground.

## 2.8.6 Marking tape

Where required, marking tape conforming to AS/NZS 2648.1 shall clearly identify the contents of the service.

## Section 3 Sizing of water services

### 3.1 Scope of section

This section specifies requirements for the sizing of pipes for water service installations.

### 3.2 Flow requirements

#### 3.2.1 Flow rates

The flow rates to fixtures, appliances, taps, valves and cisterns shall be not less than the flow rates specified in [Table 3.2.1](#).

A cold water outlet from a shower, basin, kitchen sink or laundry trough shall have a maximum flow rate of not more than 9 L/min. These requirements do not apply to a shower intended to provide rapid drenching of a person for emergency purposes, such as chemical removal.

**Table 3.2.1 — Minimum flow rates and loading units**

Fixture/appliance	Flow rate L/s	Flow rate L/min	Loading units
Water closet cistern	0.10	6	2
Bath	0.30	18	8
Basin (standard outlet)	0.10	6	1
Spray tap	0.03	1.8	0.5
Shower	0.10	6	2
Sink (standard tap)	0.12	7	3
Sink (aerated tap)	0.10	6	2
Laundry trough	0.12	7	3
Washing machine/dishwasher	0.20	12	3
Mains pressure water heater	0.20	12	8
Hose tap (20 nom. size)	0.30	18	8
Hose tap (15 nom. size)	0.20	12	4
NOTE 1 In the case of valves and appliances where test information indicates that they will function satisfactorily with a flow rate less than that shown in this Table, the tested flow rate may be substituted and the loading units adjusted accordingly.			
NOTE 2 Flow rates and loading units given above are taken with cold water flowing from each individual outlet.			

#### 3.2.2 Loading units

Loading units are factors that take into account the flow rate, length of time in use, and frequency of use of the fixture or appliance. Loading units shall be as specified in [Table 3.2.1](#).

#### 3.2.3 Probable simultaneous demand

The probable simultaneous demand (PSD) for dwellings shall be not less than that specified in [Table 3.2.3](#).

The minimum flow rates specified in [Table 3.2.3](#) shall be used to estimate the size of the supply pipe for dwellings.

NOTE See [Appendix C](#) for a method of sizing supply piping for dwellings.

**Table 3.2.3 — Minimum probable simultaneous demand for dwellings**

Number of units or dwellings	Flow rate L/s	Number of units or dwellings	Flow rate L/s	Number of units or dwellings	Flow rate L/s
1	0.48	35	3.74	68	5.79
2	0.70	36	3.81	69	5.85
3	0.88	37	3.88	70	5.91
4	1.03	38	3.95	71	5.96
5	1.17	39	4.01	72	6.02
6	1.30	40	4.08	73	6.08
7	1.41	41	4.14	74	6.13
8	1.53	42	4.21	75	6.19
9	1.64	43	4.27	76	6.25
10	1.74	44	4.34	77	6.30
11	1.84	45	4.40	78	6.36
12	1.94	46	4.47	79	6.41
13	2.03	47	4.53	80	6.47
14	2.12	48	4.59	81	6.53
15	2.21	49	4.66	82	6.58
16	2.30	50	4.72	83	6.64
17	2.39	51	4.78	84	6.69
18	2.47	52	4.84	85	6.75
19	2.55	53	4.90	86	6.80
20	2.64	54	4.96	87	6.86
21	2.72	55	5.02	88	6.91
22	2.79	56	5.09	89	6.96
23	2.87	57	5.15	90	7.02
24	2.95	58	5.21	91	7.07
25	3.03	59	5.27	92	7.12
26	3.10	60	5.32	93	7.18
27	3.17	61	5.38	94	7.23
28	3.25	62	5.44	95	7.29
29	3.32	63	5.50	96	7.34
30	3.39	64	5.56	97	7.39
31	3.46	65	5.62	98	7.44
32	3.53	66	5.68	99	7.50
33	3.60	67	5.73	100	7.55
34	3.67	—	—	—	—

NOTE 1 The minimum flow rates shown in this table are based on domestic installations. If it is expected that the dwelling(s) will have a greater demand, then the probable simultaneous flow rates may be estimated using the loading unit method outlined in [Appendix D](#).

**Table 3.2.3** (continued)

Number of units or dwellings	Flow rate L/s	Number of units or dwellings	Flow rate L/s	Number of units or dwellings	Flow rate L/s
NOTE 2 Determination of PSD for dwellings exceeding the scope of this table may be estimated using the following equation:					
$Q = 0.03 n + 0.4554 \sqrt{n}$					
where					
$Q$ = flow rate, in litres per second					
$n$ = number of dwellings					

### 3.2.4 Probable simultaneous flow rates

Conversion of loading units to probable simultaneous flow rates (PSFRs) for branch piping within dwellings is given in [Table 3.2.4](#).

NOTE 1 A method for sizing of piping within dwellings is given in [Appendix D](#).

NOTE 2 The flow rates given in [Table 3.2.4](#) may be used to estimate the minimum size of piping within dwellings.

**Table 3.2.4 — Probable simultaneous flow rates**

Loading units	PSFR L/s	Loading units	PSFR L/s	Loading units	PSFR L/s
1	0.09	21	0.39	41	0.55
2	0.12	22	0.40	42	0.56
3	0.14	23	0.41	43	0.57
4	0.16	24	0.42	44	0.58
5	0.18	25	0.43	45	0.58
6	0.20	26	0.43	46	0.59
7	0.22	27	0.44	47	0.60
8	0.24	28	0.45	48	0.60
9	0.25	29	0.46	49	0.61
10	0.26	30	0.47	50	0.62
11	0.28	31	0.48	51	0.62
12	0.29	32	0.49	52	0.63
13	0.30	33	0.49	53	0.64
14	0.31	34	0.50	54	0.64
15	0.33	35	0.51	55	0.65
16	0.34	36	0.52	56	0.65
17	0.35	37	0.52	57	0.66
18	0.36	38	0.53	58	0.67
19	0.37	39	0.54	59	0.67
20	0.38	40	0.55	60	0.68

### 3.3 Pressure requirements

#### 3.3.1 Available pressure

Pipe sizing shall be based on the minimum available pressure.

NOTE The maximum and minimum pressures for the water main serving the property may be obtained from the utility responsible for the supply of water.

#### 3.3.2 Pressure at outlets

The minimum working pressure at the furthestmost or most disadvantaged fixture or outlet shall be not less than 50 kPa (5 m head), at the flow rate specified in [Table 3.2.1](#).

NOTE 1 Storage tanks conforming to [Section 8](#) or booster pumps conforming to [Section 13](#) may be required to achieve the minimum pressure.

NOTE 2 Some fixtures may require more than 50 kPa supply pressure in order to function.

#### 3.3.3 Pressure losses

Allowance shall be made for pressure losses through pipes, valves, fittings, meters and any other equipment present in the installation.

NOTE The methods used in [Appendices C](#) and [D](#) make an allowance of 50 % additional pipe length for pressure losses through fittings.

#### 3.3.4 Maximum pressure within buildings

The maximum static pressure at any outlet, other than a fire service outlet, within a building shall not exceed 500 kPa.

NOTE Pressures above 500 kPa can cause damage from water hammer, reduced life of appliances, taps and fittings, and cause excessive noise in the system.

#### 3.3.5 Availability of water supply

Where the available water supply cannot meet the minimum pressure and flow rates of this section, storage tanks with or without pumps shall be installed to achieve the pressure and flow rate demands in accordance with this section.

### 3.4 Velocity requirements

The maximum water velocity in piping shall be 3.0 m/s.

The velocity limitation shall not apply to any piping that is exclusively used for fire services, whether independently served by a main or combined with a domestic water supply.

### 3.5 Pipe size limitations

#### 3.5.1 Water service

For a single dwelling, the water service pipe from the property service to branch off-takes shall have an internal diameter of not less than 15.0 mm.

Internal diameter of pipes shall be as specified in [Appendix A](#).

NOTE Where the installation includes home fire sprinklers or some other specialist systems, a water service of this size will be inadequate and pipe sizes will need to be determined by specific hydraulic design.

**C3.5.1** *Minimum internal diameter sizes quoted in this document have been derived from copper piping systems.*

### 3.5.2 Branch offtakes

Branch offtake pipes shall —

- (a) be of a length not exceeding those specified in [Table 3.5.2](#); and
- (b) supply only one fixture or outlet, except that —
  - (i) a branch with a minimum internal diameter of 12.5 mm may also supply a flushing device or a supply tank feeding a gravity-fed, domestic-type water heater; and
  - (ii) a branch with a minimum internal diameter of 10.0 mm may supply a combination bath and shower unit, or a laundry trough and washing machine, or a kitchen sink and dishwasher.

NOTE See [Appendix A](#) for minimum internal diameter of pipes.

**Table 3.5.2 — Branch offtake pipe-length**

Internal diameter of offtake pipe mm	Maximum length m
12.5	6
10.0	3
7.0	1

## Section 4 Cross-connection control and backflow prevention

### 4.1 Scope of section

This section specifies requirements and methods for the prevention of contamination of the drinking water within the water service and the water main and provides for the selection and installation of backflow prevention devices.

NOTE See [Appendix E](#) for typical examples of potential cross-connections.

### 4.2 Protection of water supplies

#### 4.2.1 Design

All water supply systems shall be designed, installed, and maintained to prevent contaminants from being introduced into the drinking water supply system.

#### 4.2.2 Protection against contaminants

No device or system that may cause contamination of a water supply shall be connected directly or indirectly to any part of a water service without appropriate cross-connection or backflow prevention control suitable for the degree of hazard.

#### 4.2.3 Combined tanks

Combined tanks storing drinking water and water for other purposes shall achieve separation of the storage compartments by the internal installation of double partition walls. The space between the partition walls shall be arranged to ensure that any leakage is not able to enter the other compartment of the tank and is drained such that any discharge is external to the tank and readily noticed.

#### 4.2.4 Alternative water supplies

Where water supplied from one source is connected to another water source, appropriate backflow prevention shall be provided.

NOTE This includes connections between drinking and non-drinking water supplies or multiple non-drinking water supplies.

#### 4.2.5 Integral backflow prevention

Where backflow prevention devices are provided as an integral part of a fixture, appliance or apparatus and are appropriate for the cross-connection hazard generated by that fixture, appliance or apparatus, no additional backflow prevention is required upstream of the point of connection to the water supply system.

NOTE Where a cross-connection is found in the water service at any property or if the water service is installed in a manner that will enable backflow to occur, such cross-connection should be reported to the water utility in Australia and territorial authority in New Zealand.

### 4.3 Cross-connection hazard rating

Cross-connections are rated using three degrees of hazard, as follows:

- (a) *High hazard* — Any condition, device or practice that, in connection with the water supply system, has the potential to cause death.
- (b) *Medium hazard* — Any condition, device or practice that, in connection with the water supply system, has the potential to endanger health.

- (c) *Low hazard* — Any condition, device or practice that, in connection with the water supply system, constitutes a nuisance but does not endanger health or cause injury.

#### 4.4 Provision of backflow prevention devices

##### 4.4.1 General

The required backflow protection shall be determined by identifying the individual hazard(s) within the premises. Then working upstream from each hazard, the water shall be regarded as non-drinking until a backflow prevention device, suitable for the degree of hazard, is provided.

NOTE 1 See [Figure 4.4.1](#) for typical backflow prevention.

The drinking water supply shall be protected from the hazard(s) by installing —

- (a) individual protection at each hazard with a device listed in [Table 4.4.1](#), depending on the hazard rating;
- (b) zone protection with a device listed in [Table 4.4.1](#), depending on the hazard rating, and pipework identified in accordance with [Clause 4.4.5](#);
- (c) containment protection including devices for fire service installations with a device listed in [Table 4.4.1](#); or
- (d) combinations of (a), (b) and (c).

Registered air gaps and registered break tanks shall conform to AS 2845.2.

NOTE 2 In New Zealand, NZBC Acceptable Solution G12/AS1 includes acceptable test methods for backflow prevention devices and verification of air gaps.

NOTE 3 In assessing a backflow condition, consideration should be given to the complexity of piping, the probability of piping change, and negligent or incorrect use of equipment resulting in a backflow condition.

NOTE 4 Refer to AS/NZS 2845.1 for information on materials, design and performance requirements for backflow prevention devices.

NOTE 5 See [Appendix E](#) for typical examples of potential cross-connection.

***C4.4.1*** *Types of backflow prevention may include —*

- (a) *individual protection provided at individual fixtures, appliances or apparatus;*
- (b) *zone protection provided at the connection to specific sections of a water supply system within a building or a facility;*
- (c) *containment protection provided at the property boundary to protect the network utility operator's water supply; or*
- (d) *combinations of (a), (b) and (c).*

Table 4.4.1 — Suitability of devices

Registered or testable backflow prevention device	Cross-connection hazard rating	Protection against back-pressure	Protection against back-siphonage
<b>(a) Registered testable devices</b>			
Registered break tank (RBT)	High/medium/low	Yes	Yes
Registered air gap (RAG)	High/medium/low	Yes	Yes
Reduced pressure zone device (RPZD) <sup>a</sup>	High/medium/low	Yes	Yes
Reduced pressure detector assembly (RPDA) <sup>a</sup>	High/medium/low	Yes	Yes
Double-check valve assembly (DCV) <sup>a</sup>	Medium/low	Yes	Yes
Double-check detector assembly (DCDA) <sup>a</sup>	Medium/low	Yes	Yes
Spill resistant pressure type vacuum breaker (SPVB) <sup>a</sup>	High/medium/low	No	Yes
Pressure type vacuum breaker (PVB) <sup>a</sup>	High/medium/low	No	Yes
<b>(b) Non-testable devices</b>			
Dual-check valve with atmospheric port (DCAP) <sup>b</sup>	Low	Yes	Yes
Dual-check valve (DUAL CV) <sup>b</sup>	Low	Yes	Yes
Dual-check valve with intermediate vent (DuCV) <sup>b</sup>	Low	Yes	Yes
Air gap (AG)	High/medium/low	No	Yes
Break tank (BT)	Low	No	Yes
Atmospheric vacuum breaker (AVB) <sup>b</sup>	High/medium/low	No	Yes
Hose connection vacuum breaker (HCVB) <sup>b, c</sup>	Low	No	Yes
Beverage dispenser dual-check valve (BDDC) <sup>b</sup>	Low	Yes	Yes
Pipe interrupter device (PID)	Low	No	Yes
<b>(c) Fire services in Australia only</b>			
Single check valve (testable) (SCVT) <sup>a</sup>	Low	Yes	Yes
Single check detector assembly (testable) (SCDAT) <sup>a</sup>	Low	Yes	Yes
<p><sup>a</sup> Backflow prevention devices that are provided with test taps for the purposes of testing the operation of the devices, which do not necessarily include isolating valves.</p> <p><sup>b</sup> Backflow prevention devices that are not provided with test taps for the purposes of testing the operation of the devices.</p> <p><sup>c</sup> HCVBs are designed to withstand the small amount of back-pressure that would occur if the end of the hose is higher than the hose tap.</p> <p>NOTE 1 PVBs are designed to vent at 7 kPa or less; however, they may require a significantly higher pressure to reseal and should be installed only in systems that provide pressures sufficient to ensure full closing of the valve and should not be installed close to water outlets where low pressures may be encountered.</p> <p>NOTE 2 In areas where water spillage may cause nuisance, tundishes or alternative drainage should be installed to receive the discharge from — (a) RPZDs; (b) PVBs; (c) DCAP; or (d) AVBs.</p> <p>NOTE 3 SPVBs, PVBs, AVBs, HCVBs and PIDs should only be used to protect against back-siphonage.</p>			

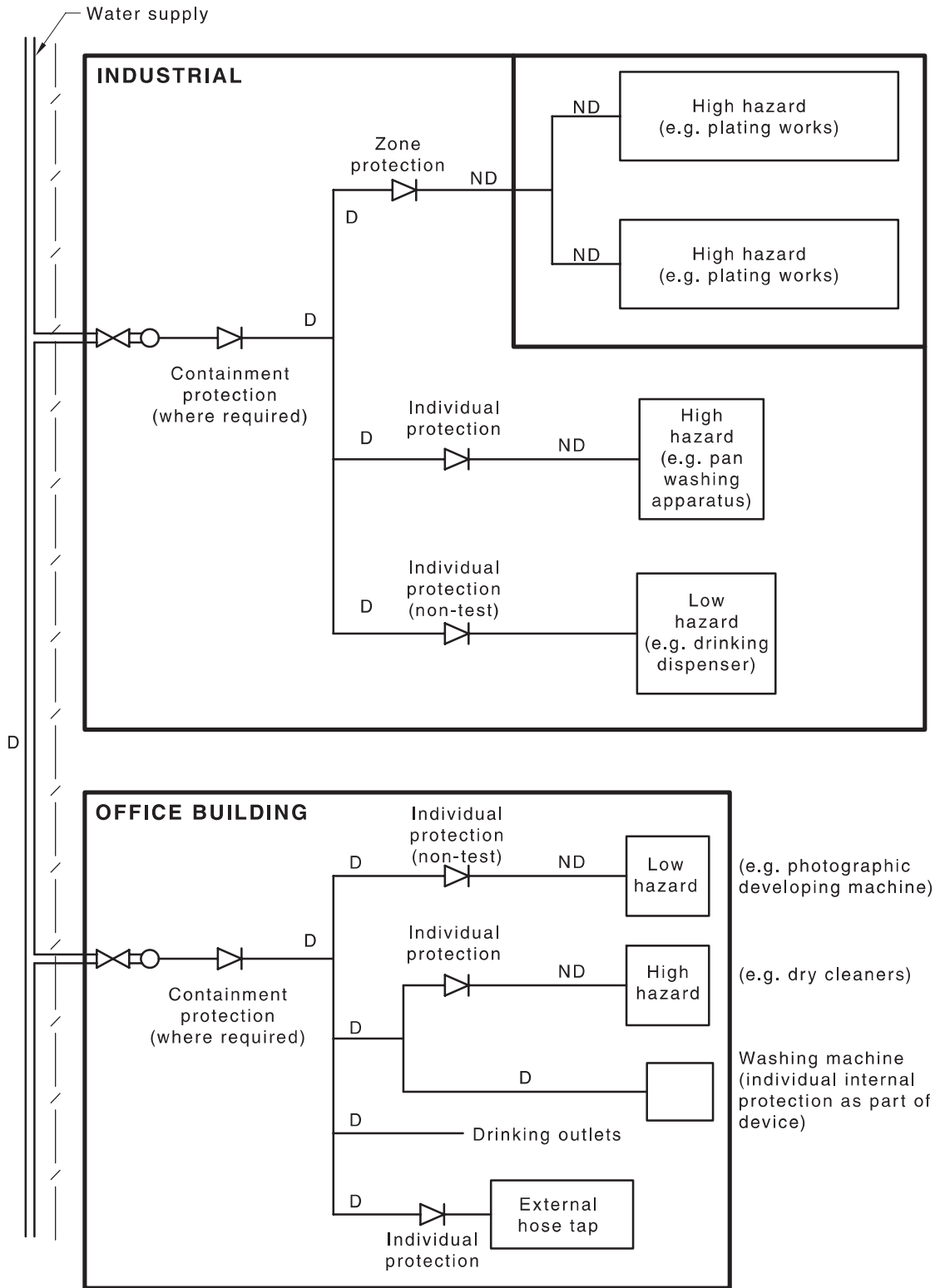

Key:  
 D = drinking water  
 ND = non-drinking water  
 = backflow prevention device  
 - - - = boundary

Figure 4.4.1 — Typical backflow prevention schemes

Copyrighted material. Licensed to TASTAFE by Techstreet LLC, subscriptions.techstreet.com, downloaded on 2023-10-05 21:03:06 +0000 by TASTAFE User. No further reproduction or distribution is permitted.

#### 4.4.2 Type of backflow protection

Backflow prevention devices shall be provided as appropriate to —

- (a) the hazard rating given in [Clause 4.3](#); and
- (b) the suitability of the device listed in [Table 4.4.1](#).

NOTE 1 In Australia, the requirements for cross-connection control are contained in the Plumbing Code of Australia.

NOTE 2 In New Zealand, refer to New Zealand Building Code Acceptable Solution G12/AS1 for examples of cross connection hazards and applicable hazard ratings.

#### 4.4.3 Hose taps

Hose taps within 18 m of a zone-protected area within the same premises shall have a backflow protection device of the same hazard rating as the zone protection adjacent to which they are installed.

#### 4.4.4 Additional backflow protection

Where cross-connections are identified, zone(s) or individual backflow prevention devices appropriate to the hazard rating given in [Clause 4.3](#) shall be installed.

NOTE 1 For typical examples of potential cross-connections, see [Figure 4.4.1](#) and [Appendix E](#).

NOTE 2 Additional backflow protection may also be required by the network utility operator.

#### 4.4.5 Water downstream of backflow prevention device

Water downstream of a containment device is considered to be drinking water unless there are unprotected hazards within the premises.

Individual or zone protection against these hazards shall be provided to prevent contamination of the water supply.

The water service downstream of a backflow prevention device shall not be reconnected to the water service upstream of the backflow prevention device without the installation of a backflow prevention device of the same hazard rating.

Piping conveying water downstream of a backflow prevention device, installed for high or medium hazard protection, other than a backflow prevention device used for containment, shall be clearly and permanently labelled at every outlet with a prohibition sign conforming to [Clause 9.7.2](#).

NOTE See [Section 9](#) for requirements for non-drinking water.

#### 4.4.6 Commissioning

Testable backflow prevention devices shall be commissioned and tested in accordance with AS/NZS 2845.3 after installation and prior to service. Reduced pressure zone devices, double check valve assemblies, pressure type vacuum breakers, registered break tanks and registered air gaps shall only be used with a maintenance program for device registration and test certification.

Where there is no such program, these devices shall not be fitted and the standard requirements for air gaps shall apply.

NOTE 1 In New Zealand, the testing of automatic backflow protection devices is required for compliance with the Building Act 2004 as part of issuing a building compliance schedule and annual building warrant of fitness.

NOTE 2 In Australia, ongoing field testing and maintenance may be prescribed by state and territory legislation.

#### 4.4.7 Heated water systems

The requirements of this section for backflow prevention devices apply equally to heated water supply systems and cold water supply services. The backflow prevention device used in heated water systems shall be suitable for the specific heated water installation.

#### 4.5 Suitability of devices for hazards

[Table 4.4.1](#) lists devices suitable for each hazard rating and indicates whether protection is provided against back-pressure or back-siphonage.

The type of device selected for each hazard rating shall conform to [Table 4.4.1](#).

#### 4.6 Installation of backflow prevention devices

##### 4.6.1 General installation requirements

The installation of each backflow prevention device shall conform to the following:

- (a) Heat shall not be applied to any device during installation.
- (b) Except for fire services, the following shall be fitted with line strainers:
  - (i) Pressure type vacuum breaker (PVB).
  - (ii) Spill resistant pressure type vacuum breaker (SPVB).
  - (iii) Double check valve (DCV).
  - (iv) Double detector check valve (DDCV).
  - (v) Reduced pressure zone device (RPZD).
  - (vi) Detector reduced pressure zone device (DRPZD).
- (c) Line strainer elements shall be as specified in [Table 4.6.1](#).
- (d) For all testable devices, resilient-seated (drop tight when closed) isolating valves shall be installed —
  - (i) immediately upstream of the line strainer or immediately upstream of the device in cases where no integral line strainer is fitted [see Item (b)]; and
  - (ii) immediately downstream of the device.
- (e) Piping shall be flushed before devices are connected.
- (f) Unprotected bypasses shall not be installed around backflow prevention devices.
- (g) The devices shall be installed in accordance with [Clause 4.6.3](#).
- (h) The devices shall be protected from damage, including freezing.
- (i) Where continuous water supply is essential, devices shall be installed in parallel to permit shutdown of a device.
- (j) In-line devices shall be capable of being removed and replaced.

**Table 4.6.1 — Maximum orifice diameters and maximum centre distances of line strainer element perforations**

Size DN	Maximum orifice diameter mm	Maximum centre distance mm
20	1.6	2.4
25	1.6	2.4
32, 40, 50	3.25	5.6
80, 100, 150	4.6	5.6
200, 250, 300	4.6	5.6

## 4.6.2 Location of devices

### 4.6.2.1 General

The location of each backflow prevention device shall conform to the following:

- (a) Backflow prevention devices shall not be located in a corrosive or polluted atmosphere where the contaminated air can enter the piping system through the air gap or open vent port or cause the device to malfunction.
- (b) Insulation or any other protection of a backflow prevention device shall not interfere with its operation, testing or maintenance.
- (c) Vented testable backflow prevention devices shall not be located in cabinets without drainage or in pits without drainage.
- (d) Backflow prevention devices shall not be buried in the ground.
- (e) Where water hammer occurs, it shall be rectified by the installation of a surge protector or water hammer arrestor.
- (f) All in-line devices shall be installed with connections to permit the removal and replacement of the device.
- (g) Containment devices shall be located as close as practicable to the point of connection and downstream of any water meter. There shall be no branch connection between the meter and device.

### 4.6.2.2 Accessibility

All devices shall be readily accessible for ease of maintenance or testing without the need to work from ladders or scaffolding.

Where the device is fitted with test taps, their location shall ensure the clearance necessary for the performance of the applicable test procedure and maintenance.

### 4.6.2.3 Drainage and leakage

Backflow prevention devices shall be positioned so that any leakage from air ports of vacuum breakers and openings on pipe interrupter devices, or discharge from reduced pressure zone devices and dual-check valves with atmospheric port, is readily visible, but does not constitute a hazard or nuisance.

## 4.6.3 Specific installation requirements for testable and non-testable devices

### 4.6.3.1 General

Backflow prevention devices shall be installed in accordance with [Clauses 4.6.1](#), [4.6.3.2](#) and [4.6.3.3](#).

#### 4.6.3.2 Testable devices

Testable devices shall be installed as follows:

- (a) *Registered break tank (RBT) and registered air gap (RAG)* — RBTs shall conform to [Section 8](#) of this document and incorporate the following air gap requirements:
  - (i) The unobstructed vertical distance through the free atmosphere between the lowest opening of a water service pipe or fixed outlet supplying water to an RBT and the highest possible water level of such RBT shall be as given in [Table 4.6.3.2](#).
  - (ii) Where any break tank receives water from two or more water services of different diameter, the air gap shall be not less than the air gap required for the largest effective opening of the water service outlets as given in [Table 4.6.3.2](#).
- (b) *Pressure type vacuum breaker (PVB)* — PVBs shall —
  - (i) be located not less than 300 mm above the highest outlet;
  - (ii) be ventilated to the atmosphere at all times; and
  - (iii) not be located in an area that may be subjected to ponding or freezing.
- (c) *Double-check valve (DCV) assembly* — DCV assemblies shall be located so as not to be subject to freezing.
- (d) *Reduced pressure zone device (RPZD)* — RPZDs shall —
  - (i) have free ventilation to the atmosphere for the relief valve outlet, at all times;
  - (ii) not be located in an area that may be subjected to ponding or freezing;
  - (iii) have the relief drain outlet located not less than 300 mm above the finished surface level.
- (e) *Double-check detector assembly (DCDA)* — DCDA shall be located so that they are not subjected to freezing.
- (f) *Reduced pressure detector assembly (RPDA)* — RPDA shall —
  - (i) have free ventilation to the atmosphere for the relief valve, at all times;
  - (ii) not be located in an area subject to ponding or freezing;
  - (iii) have the relief drain outlet located not less than 300 mm above the finished surface level.
- (g) *Spill resistant pressure vacuum breaker (SPVB)* — SPVBs shall —
  - (i) be located not less than 300 mm above the highest outlet;
  - (ii) be ventilated to atmosphere at all times; and
  - (iii) not be located in areas that may be subjected to ponding.
- (h) *Single check valve (testable) (SCVT)* — SCVTs shall —
  - (i) be located so as not to be subjected to freezing;
  - (ii) have isolating valves installed immediately upstream and downstream of the device;
  - (iii) be fitted in an accessible position; and

- (iv) be used only in fire services.
- (i) *Single check detector assembly (testable) (SCDAT)* — SCDATs shall —
  - (i) be located so as not to be subjected to freezing;
  - (ii) have isolating valves installed immediately upstream and downstream of the device;
  - (iii) be fitted in an accessible position; and
  - (iv) be used only in fire services.

**Table 4.6.3.2 — Minimum air gap**

Diameter of the effective opening of water service outlet	Minimum air gap, mm	
	When not affected by near wall	When affected by near wall
≤ 9	20	25
> 9 ≤ 12	25	40
> 12 ≤ 20	40	55
> 20 ≤ 25	50	75
> 25	2 × effective opening	3 × effective opening

**4.6.3.3 Non-testable devices**

Non-testable devices shall be installed as follows:

- (a) *Atmospheric vacuum breaker (AVB)* — AVBs shall —
  - (i) be located not less than 150 mm above the highest outlet;
  - (ii) have no isolating valves located downstream of the vacuum breaker;
  - (iii) under normal operation, not remain continuously pressurized for more than 12 h;
  - (iv) be ventilated to the atmosphere, at all times;
  - (v) not be located in an area that may be subject to ponding; and
  - (vi) be located in-line and be at least the same size as the supply and discharge piping.
- (b) *Hose connection vacuum breaker (HCVB)* — HCVBs shall —
  - (i) be located downstream of the isolating valve;
  - (ii) not, under normal operation, remain continuously pressurized with water for more than 12 h; and
  - (iii) be ventilated to the atmosphere at all times.
- (c) *Dual-check valve with atmospheric port (DCAP)* — DCAPs shall —
  - (i) not be located in an area that is subject to ponding or freezing; and
  - (ii) have the vent port located not less than 300 mm above the finished surface level so that the device is freely drained or over a tundish.

NOTE 1 See [Clause 4.6.2.3](#) for information on leakage from devices.

- (d) *Dual check valve (DUAL CV)* — DUAL CVs shall not be located in an area subject to freezing.

- (e) *Dual check valve with intermediate vent (DuCV)* — DuCVs shall —
- (i) not be located in an area that is subject to ponding; and
  - (ii) have the vent port located not less than 300 mm above the finished surface level so that the device is freely drained or over a tundish.

NOTE 2 See [Clause 4.6.2.3](#) for information on leakage from devices.

- (f) *Beverage dispenser dual-check valve (BDDC)* — BDDCs shall —
- (i) not be located in an area that is subject to freezing; and
  - (ii) have the vent port located not less than 300 mm above the finished surface level so that the device can drain freely.

NOTE 3 See [Clause 4.6.2.3](#) for information on leakage from devices.

- (g) *Single-check valve — Spring loaded (Australia only)* — Spring-loaded single-check valves shall —
- (i) have an isolating valve installed upstream and adjacent to the device;
  - (ii) be fitted in an accessible position; and
  - (iii) only be used in fire services.

- (h) *Pipe interrupter device (PID)* — PIDs shall —
- (i) not be installed in a continuous pressure system; and
  - (ii) be located not less than 300 mm above the finished surface level so the device can drain freely.

NOTE 4 See [Clause 4.6.2.3](#) for information on leakage from devices.

## Section 5 Installation of cold water services

### 5.1 Scope of section

This section specifies requirements for the installation of pipes, fittings, and apparatus used in cold water services.

NOTE Refer to AS/NZS 3500.4 for information on installation of heated water services.

*C5.1 Safety precautions need to be observed when cutting into pipework or disconnecting water meters, fittings and devices on pipework. There have been fatalities and injuries that have been attributed to water services carrying an electrical current.*

*Where existing metallic service pipework is to be replaced in part or in its entirety by plastics pipe or other non-metallic fittings or couplings, the work should not commence until the earthing requirements have been checked by an electrical contractor and modified if necessary.*

### 5.2 Installation of pipes and fittings

#### 5.2.1 Copper pipes and fittings

Copper pipes and fittings shall be installed in accordance with AS 4809.

#### 5.2.2 Plastics pipes and fittings

##### 5.2.2.1 Installation of PVC pipe systems

PVC pipe systems shall be installed in accordance with AS/NZS 2032.

NOTE PVC materials include PCV-U, PCV-M, PVC-O and PVC-C.

##### 5.2.2.2 Installation of ABS pipe systems

ABS pipe systems shall be installed in accordance with AS/NZS 3690.

##### 5.2.2.3 Installation of PE pipe systems

PE pipe systems shall be installed in accordance with AS/NZS 2033.

##### 5.2.2.4 Installation of other plastics pipe systems

NOTE Installation should take into account manufacturer's instructions.

### 5.3 Proximity to other services

#### 5.3.1 General

Where electrical conduits, wires, cables or consumer gas pipes, drains and other services are in place, pipes shall be installed in accordance with the requirements of [Clauses 5.3.2](#) to [5.3.5](#).

#### 5.3.2 Above-ground services

Separation of at least 25 mm shall be maintained between any above-ground water service and any of the following services:

- (a) Electrical or telecommunications conduits.

- (b) Electrical or telecommunications wires or cables.
- (c) Consumer gas pipes.
- (d) Sanitary plumbing and drainage.
- (e) Storm water drainage.
- (f) Other above-ground water services.
- (g) Any other services.

Where a pipe is insulated, the measurement shall be from the outer edge of any insulation or wrapped material applied to the pipework.

### 5.3.3 Below-ground services

#### 5.3.3.1 Electrical

The following shall apply:

- (a) The separation between any underground water service pipe and an electrical supply cable, shall be at least —
  - (i) 100 mm for a water service pipe not greater than DN 65, where the electrical supply cable is indicated along its length with orange marker tape and is mechanically protected;
  - (ii) 300 mm for a water service pipe greater than DN 65, where the electrical supply cable is indicated along its length with orange marker tape and is mechanically protected; or
  - (iii) 600 mm where the electrical supply cable is neither indicated nor protected in accordance with Items (a) or (b).
- (b) The separation between any underground water service pipe and an extra-low voltage, not exceeding 50 V a.c. or 120 V ripple-free d.c. electrical supply, shall be at least 100 mm.

NOTE 1 Refer to AS/NZS 3000 for a definition of high voltage cable.

- (c) For an electrical supply not exceeding 1 000 V, the separation between any underground water service pipe and an electrical earthing electrode shall be at least 500 mm.

NOTE 2 Mechanical protection may be provided by concrete slabs, continuous concrete pour, polymeric cover strips, or bricks designed for protecting electrical supply cables and may include a suitable conduit.

NOTE 3 For an electrical supply exceeding 1 000 V, refer to the relevant regulatory authority for a ruling.

#### 5.3.3.2 Gas

The separation between any underground water service pipe and consumer gas pipes shall be at least —

- (a) 100 mm for a water service pipe not greater than DN 65, provided the consumer gas pipe is indicated along its length with marker tape conforming to AS/NZS 2648.1 and laid 150 mm above the installed pipe;
- (b) 300 mm for a water service pipe greater than DN 65, provided the consumer gas pipe is indicated along its length with marker tape conforming to AS/NZS 2648.1 and laid 150 mm above the installed pipe; or

- (c) 600 mm where the consumer gas pipe is neither indicated nor mechanically protected.

NOTE See [Clause 5.3.3.3](#) for information on clearance from a communication cable.

### 5.3.3.3 Communication services

The separation between any underground water service pipe and a communication cable shall be at least 100 mm.

### 5.3.3.4 Stormwater and sanitary drainage

The following apply:

- (a) Water services pipes shall not be laid in or through any drain.
- (b) A water service pipe may be laid in the same trench as a drain, provided the following conditions are observed:
- The water service pipe is located on a shelf or ledge, excavated at one side of the trench, not less than 50 mm from the continuation of the trench, or on compacted bedding such that the horizontal separation of the two pipes is not less than 100 mm and the required depth of cover is maintained.
  - The underside of the water pipe is at least 100 mm above the top of the drain.

NOTE See [Figure 5.3.3.4](#) for the laying of water supply piping in the same trench as a drain.

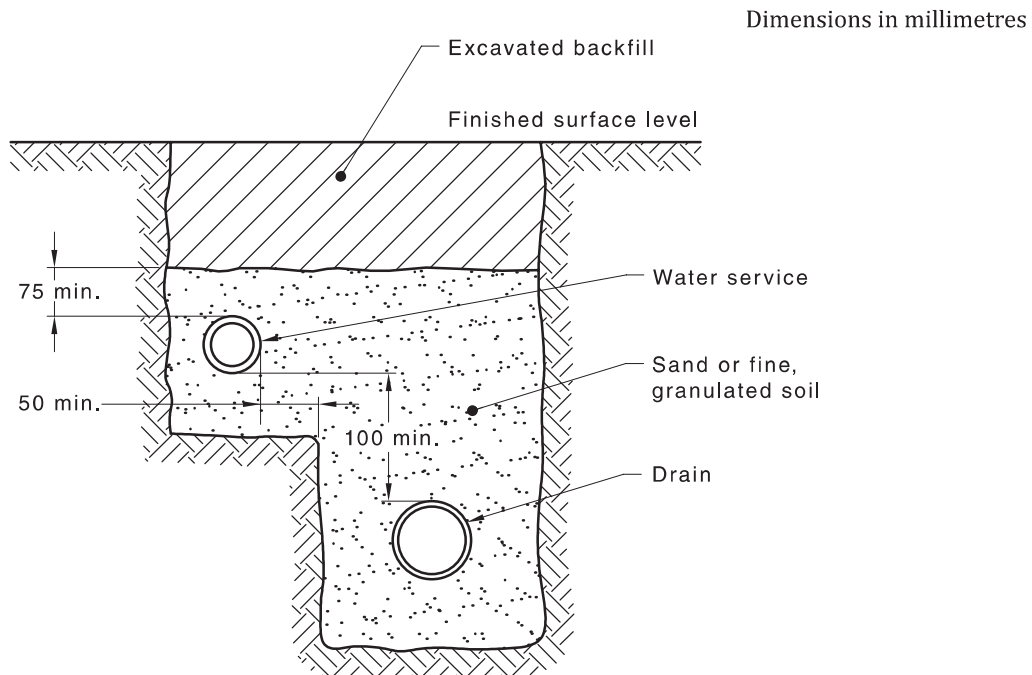

**Figure 5.3.3.4 — Laying of water supply piping in same trench as a drain**

### 5.3.3.5 Non-drinking water

Water services shall be separated from a non-drinking water service in accordance with [Clause 9.3.2](#).

### 5.3.3.6 Other services

The separation between any underground water service pipe and any other service, other than consumer gas piping and electrical or communication service, shall be at least —

- (a) 100 mm for a water service pipe not greater than DN 65; or
- (b) 300 mm for a water service pipe greater than DN 65.

### 5.3.4 Crossover of underground services

Any underground water service crossing another service or any underground service crossing a water service shall —

- (a) cross at an angle of not less than 45°;
- (b) have a vertical separation of not less than 100 mm; and
- (c) be marked along its length for 1 m either side of the centre-line of the service with marker tape conforming to AS/NZS 2648.1 and laid 150 mm above the installed service.

### 5.3.5 Clearance from underground obstructions

Water service pipes shall be installed with sufficient clearance to any underground obstruction to protect the service from physical damage and to permit repairs. The clearance shall be at least —

- (a) 100 mm for a water service not exceeding DN 65; and
- (b) 300 mm for a water service exceeding DN 65.

## 5.4 Isolating valves

### 5.4.1 General

The flow within the water service pipes shall be controlled by means of isolating valves.

### 5.4.2 Location

Isolating valves shall be installed in the following locations:

- (a) At the water main (at either a tapping or tee insertion) and any connection to an alternative water supply.
- (b) At the water meter inlet or at the point of connection with the property service if no meter is fitted.
- (c) At each flushing cistern.
- (d) At each appliance.
- (e) At each testable backflow prevention device.
- (f) At each thermostatic mixing valve.
- (g) At each pressure-limiting or pressure-reduction valve.
- (h) At each pumping apparatus.
- (i) At each storage tank (inlet).
- (j) At each storage tank outlet (where capacity exceeds 50 L).

- (k) At each offtake point to an irrigation system.

Where a water meter is fitted outside the property, an additional isolating valve shall be installed.

NOTE Refer to AS 2118.5 or NZS 4517 for isolating valves on home fire sprinkler systems.

### 5.4.3 On fire services

On fire services, additional isolating valves shall be installed as follows:

- (a) At each water main.
- (b) At or near the property boundary.
- (c) At each hose reel.
- (d) At each pumping apparatus.

NOTE 1 A stop valve is a valve that can be operated to stop the flow in a pipeline and includes stop taps, ball valves, and gate valves.

NOTE 2 The isolating valve adjacent to the water utilities water meter should meet the requirements of AS/NZS 3718.

NOTE 3 Refer to relevant fire protection standards for locking and monitoring requirements.

### 5.4.4 Multiple dwellings

An isolating valve shall be installed on each branch serving an individual dwelling and be accessible by the individual dwelling occupier.

### 5.4.5 Maintenance

Isolating valves shall—

- (a) be installed so that they are accessible; and
- (b) withstand water pressure both upstream and downstream of the valve.

## 5.5 Location of piping

### 5.5.1 Location

The following apply to the installation of water service pipes:

- (a) Any water service branch, including valves, shall be located within the dwelling it serves.
- (b) Water service pipes shall not be embedded or cast into concrete structures.

NOTE 1 Care should be taken to ensure that the water service is not damaged during normal building activities.

NOTE 2 Concealed piping should be maintained under normal water pressure while subsequent building operations, which may cause damage to the pipes, are being carried out.

NOTE 3 All pipes should be flushed with clean water at regular intervals until the building is occupied.

NOTE 4 To prevent any unreasonable rise in the temperature of the cold water delivered to fixtures located within a building, pipes and fittings installed above the ground should be protected against the heating effects of solar radiation or other heat sources.

## 5.5.2 Concealed piping

### 5.5.2.1 Walls

Water services located in timber- or metal-framed walls shall be installed as follows:

- (a) *Timber wall framework* — Holes or notches made in timber studs and plates in walls shall be in accordance with the following:
  - (i) The maximum size and spacing of holes or notches in studs shall be in accordance with [Figure 5.5.2.1\(A\)](#) and [Table 5.5.2.1](#).
  - (ii) Where uninsulated pipes are used, a collar of lagging material or a neutral cure silicone sealant shall be used to fill the annular space.
- (b) *Timber beams, bearers and joists* — Holes or notches made in timber beams, bearers and joists in floors shall be in accordance with [Figure 5.5.2.1\(A\)](#) and [Figure 5.5.2.1\(B\)](#).
- (c) *Metal wall framework* — Water services shall be installed in existing preformed holes where possible. Additional holes, where required, shall be no larger than the preformed holes installed by the manufacturer or 32 mm when there are no pre-existing holes. The additional holes shall be placed —
  - (i) with hole centres no further from the centreline of the member than  $\pm 10\%$  of the member depth;
  - (ii) at a minimum spacing or end distance of 4 times the hole diameter (for single holes); and
  - (iii) at a minimum spacing or end distance of 8 times the hole diameter (for pair-to-pair or single-to-pair holes), see [Figure 5.5.2.1\(C\)](#).

If holes are less than 4 times the hole diameter apart, they are considered a pair.

NOTE 1 An engineered system may have more numerous or closely spaced holes depending on the design.

Holes may be plain (unflared) or flared. For plain holes, metal and polymer pipes shall be protected from contact with the hole edge. For flared holes, metal pipes shall be isolated from contact with the hole flare. Protection or isolation shall be provided using suitable grommets, insulation or a short sleeve of oversize pipe firmly secured in the framework to be inserted around the pipe. There shall be no direct contact between the pipe and framework and there shall be free longitudinal movement of the pipe through the grommet, lagging or sleeve.

NOTE 2 See [Figure 5.5.2.1\(D\)](#) for examples of the fixing of services.

All pipes shall be secured in accordance with [Clause 5.7](#).

- (d) *Metal beams, bearers and joists* — Holes made in metal beams, bearers and joists shall be in accordance with [Figure 5.5.2.1\(E\)](#).
- (e) Pipes located in cavities shall be installed so as to prevent the transfer of moisture from the outer wall to the inner wall.

NOTE 3 Care should be taken to ensure that the air cavity moisture barrier within an external wall of any building is not bridged with pipe or pipe duct penetrations and porous pipe insulation materials. A clear air gap is required between the external wall and the pipe insulation material.

**Table 5.5.2.1 — Holes and notches in studs and plates**

Symbol	Description	Limits	
		Notched	Hole
<i>A</i>	Distance between holes and/or notches in stud breadth	Min. $3D$	Min. $3D$
<i>H</i>	Hole diameter (studs and plates)	Max. 25 mm (wide face only)	Max. 25 mm (wide face only)
<i>C</i>	Notch into stud breadth	Max. 10 mm	Max. 10 mm
<i>E</i>	Notch into stud depth	Max. 20 mm (for diagonal cut in bracing only) <sup>a</sup>	Not permitted <sup>a</sup>
<i>F</i>	Distance between notches in stud depth	Min. $12B$	N/A
<i>P</i>	Trenches in plates	3 mm max.	

<sup>a</sup> A horizontal line of notches up to 25 mm may be provided for the installation of baths.

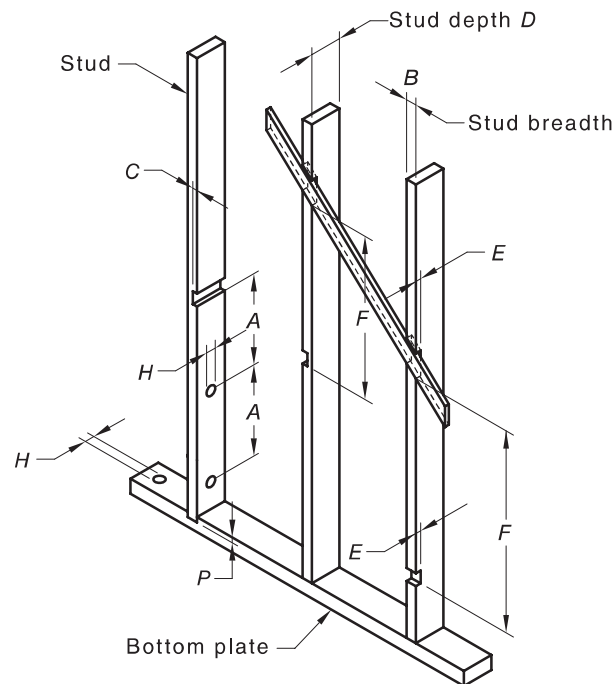
**Figure 5.5.2.1(A) — Notching of wall studs**

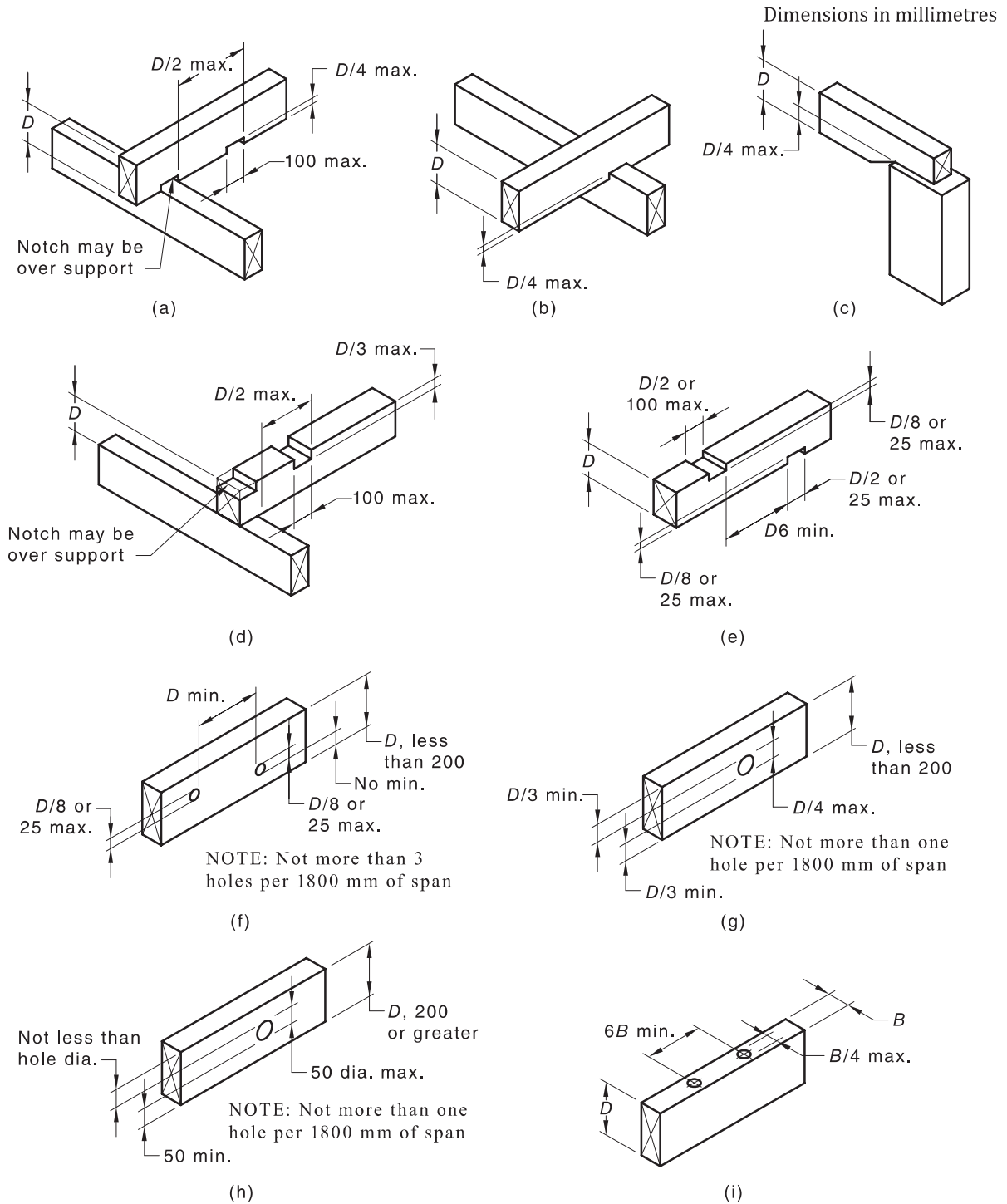

Figure 5.5.2.1(B) — Notches, cuts and holes in beams, bearers, joists, and rafters

Dimensions in millimetres

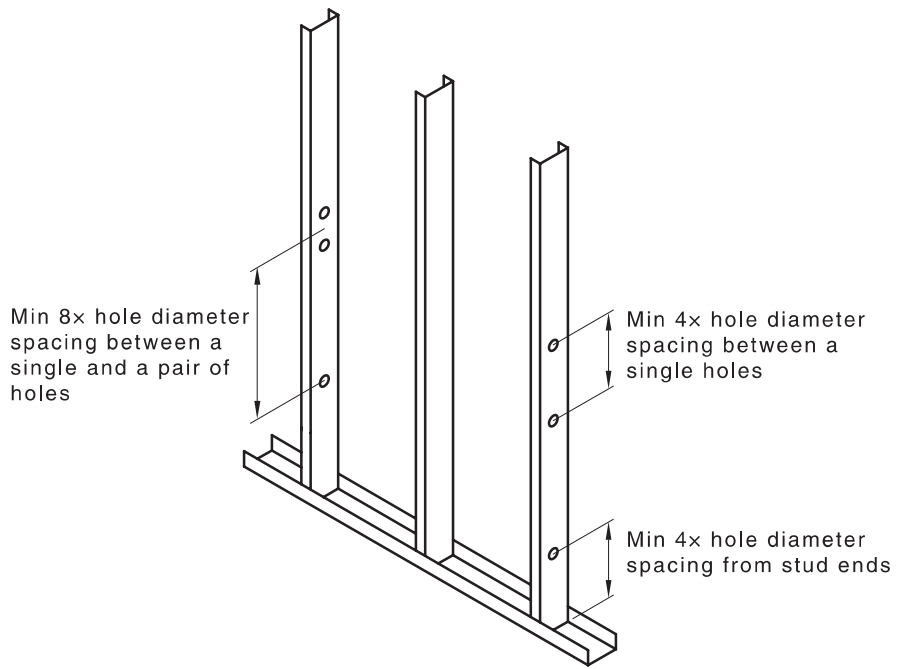
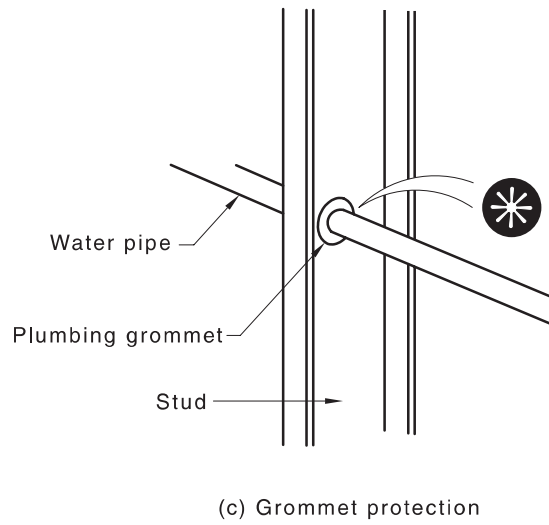
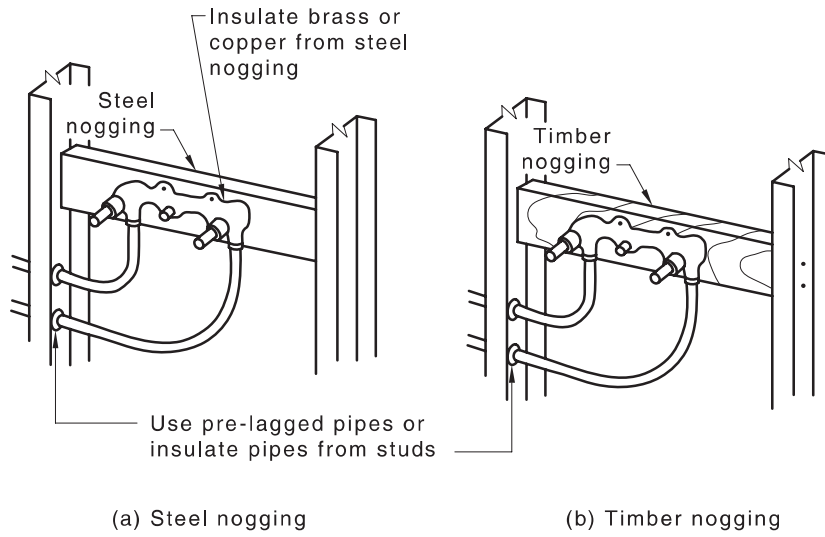
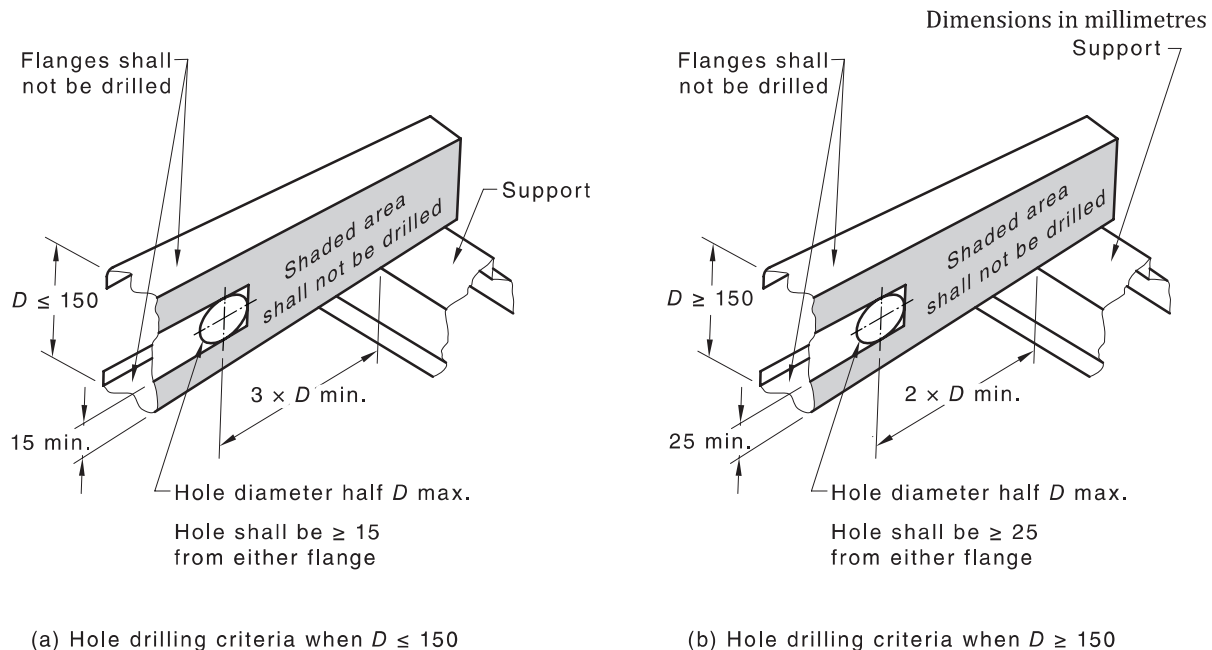

Figure 5.5.2.1(C) — Hole spacing in metal wall framework



**Figure 5.5.2.1(D) — Installation and fixing of services**



**Figure 5.5.2.1(E) — Penetrations to steel floor joists**

### 5.5.3 Chases, ducts or conduits

Pipes located in chases, ducts or conduits within walls or floors of masonry or concrete construction shall be installed in accordance with the following:

- (a) Pipes in chases shall be continuously wrapped with an impermeable flexible material.
- (b) Ducts shall be fitted with removable covers.

### 5.5.4 Under concrete slabs

Water service pipes located beneath concrete slabs on ground shall conform to the following:

- (a) Pipes shall be laid in a narrow trench on a bed of sand or fine-grained soil placed and compacted in a manner that will not damage the piping. There shall be a minimum distance of 75 mm between the top of the pipe and the underside of the slab or slab-stiffening beam.
- (b) The ends shall be crimped or capped prior to pouring of the concrete. The exposed pipe shall be protected from damage.
- (c) Any pipework that penetrates the slab shall be at right angles to the surface of the slab and lagged for the full depth of the slab penetration with —
  - (i) an impermeable flexible material of not less than 6 mm thickness; or
  - (ii) impermeable plastics sleeve or conduit providing equivalent protection.

NOTE Where termite protection is required, the integrity of the chosen termite protection method should not be compromised.

- (d) Metal pipes shall be continuously lagged with an impermeable material.
- (e) Soft-soldered joints shall not be used.
- (f) The number of joints shall be kept to a minimum.

## 5.6 Methods of jointing

### 5.6.1 General

Jointing of water services shall be in accordance with the following:

- (a) *Removal of burr* — The burr formed in cutting any pipe shall be removed.
- (b) *Joints requiring use of heat* — Pipes or fittings shall not be damaged by the application of excessive heat.
- (c) *Use of fittings* — Where straight sections of pipe of different diameter are to be joined, such increase or reduction in size shall be made by a fitting.
- (d) *Crimping* — Crimping, shall not be used when joining to reduce a larger diameter pipe to a smaller diameter pipe.
- (e) *Jointing of copper or stainless-steel pipes* — Copper or stainless-steel water service pipes of different diameter shall not be joined by filling the annular space using a filler rod.

NOTE 1 AS 3688 specifies the installation of metallic joints and end connectors.

- (f) *Fabricated fittings* — Where sockets and tees are fabricated from copper, copper alloy or stainless steel pipes:
  - (i) They shall be made using tools designed for such purposes.
  - (ii) They shall be jointed by silver brazing.
  - (iii) Copper tees shall not be fabricated from pipe of thickness less than Type C.

NOTE 2 In Australia, AS 1432 provides information on copper types.

NOTE 3 In New Zealand, NZS 3501 copper tube may also be used.

### 5.6.2 Threading

Threads shall conform to the relevant Standard for the materials to be jointed and be sealed with a compatible jointing medium.

### 5.6.3 Bolted gland and Gibault-type joints

Joints of the bolted gland type or Gibault-type may be used to join similar or dissimilar pipes and fittings of the same nominal diameter and, where they are used below ground, they shall be protected against corrosion in accordance with [Clause 5.13](#).

### 5.6.4 Jointing of copper and copper alloy pipes

Fittings used to join copper and copper alloy pipes shall be installed in accordance with the installation requirements of AS 4809.

NOTE Fittings used for copper and copper alloys include capillary, press-fit, push-fit, roll-grooved, compression and threaded end connectors.

### 5.6.5 Compression joints

Compression joints shall conform to AS 3688 or AS/NZS 4129.

Plastics nuts shall not be used to connect any pipe to a cold water storage tank that supplies water to a water heater.

NOTE In New Zealand, croxed joints without rubber olives may be used.

### 5.6.6 Flanged joints

Flanges shall be attached to pipe ends by means of —

- (a) threads for galvanized steel pipe and fittings;
- (b) silver brazing in accordance with [Clause 5.6.8.1](#) or bolting for flanges of copper alloy to copper or copper alloy pipes or fittings;
- (c) priming fluid and solvent cement for PVC-U pipes and fittings; and
- (d) set screws for cast iron pipes and fittings.

Flange joints below ground shall be protected against corrosion in accordance with [Clause 5.13](#).

### 5.6.7 Roll-grooved joints

Where used below ground, the joints shall be —

- (a) protected against corrosion with each assembled copper or copper alloy joint protected with a petrolatum-based wrapping system; and
- (b) external to a building and not under concrete.

NOTE Refer to AS 3688 for information on metallic fittings and end connectors.

### 5.6.8 Silver brazing

#### 5.6.8.1 Joints

A compatible flux shall be used when making joints.

#### 5.6.8.2 Taps and valves

Silver brazing shall not be used as a means of joining taps or valves to pipes larger than DN 20. To prevent damage, the tap assembly and jumper valve shall be removed from the body of taps and valves prior to silver brazing.

### 5.6.9 Jointing of plastics pipes

#### 5.6.9.1 PVC

Jointing of pipes and fittings of PVC material shall be carried out in accordance with AS/NZS 2032.

#### 5.6.9.2 PE

Jointing of PE pipes and fittings shall be carried out in accordance with AS/NZS 2033.

NOTE Acceptable methods for jointing are mechanical, electro-fusion, butt-fusion and socket-fusion.

#### 5.6.9.3 ABS

Jointing of ABS pipes shall be carried out in accordance with AS/NZS 3690.

#### 5.6.9.4 Other plastics pipes

Joining of PB pipes shall be carried out using fittings that are compatible with PB pipes.

NOTE 1 Refer to AS/NZS 2642.3 or AS 5082.2 for additional information on mechanical joining fittings for use in PB piping systems.

Joining of PE-X pipes shall be carried out using fittings that are compatible with PE-X pipes.

NOTE 2 Refer to the AS/NZS 2537 series for information on mechanical joining fittings for use with crosslinked polyethylene for pressure applications.

Joining of MLP pipes shall be carried out using fittings that are compatible with MLP pipes.

NOTE 3 Refer to the AS 4176 series for information on multilayer pipes for pressure applications.

Joining of PP-R pipes shall be carried out using fittings that are compatible with PP-R pipes.

NOTE 4 Refer to the ISO 15874 series for information on plastic piping systems for hot and cold water installations including appropriate PP-R fittings.

#### 5.6.10 Joining of stainless-steel pipe and fittings

##### 5.6.10.1 Joining of piping up to and including DN 25

Joints not larger than DN 25 shall be made by using either Type 1 or Type 2 mechanically jointed compression fittings or press-fit end connectors or by using silver-brazed stainless-steel capillary joints.

##### 5.6.10.2 Joining of piping larger than DN 25

Joints in stainless steel piping larger than DN 25 shall be one of the following:

- (a) Butt-welded using a tungsten inert gas (TIG) argon arc method and —
  - (i) have a gap not greater than 0.5 mm between the abutting pipe ends to be joined;
  - (ii) have inserted a backup ring 6 mm long, made from the parent pipe, to straddle the joint of pipes with a wall thickness less than 1.2 mm;
  - (iii) use a low carbon stainless steel type filler rod not greater than 2 mm in diameter; and
  - (iv) be tack welded in not less than four spots around the circumference, prior to welding the entire joint.
- (b) Flanged joints, using a stub flange, fabricated by rolling or welding to the pipe. The stub flange shall have —
  - (i) the same wall thickness as the pipe;
  - (ii) a diameter equal to the outside diameter (OD) of the mating part or have a mild steel backup flange fitted; and
  - (iii) a gasket not less than 3 mm thick inserted.
- (c) Stainless-steel press-fit end connectors.

NOTE 1 Refer to AS 2129 for information on flanges for pipes, valves and fittings.

NOTE 2 Refer to AS/NZS 4331.1 for information on steel flanges.

NOTE 3 Refer to AS/NZS 4331.2 for information on cast iron flanges.

NOTE 4 Refer to AS/NZS 4331.3 for information on copper alloy and composite flanges.

NOTE 5 Refer to ASTM A182/A182M for information on forged or rolled alloy and stainless-steel pipe flanges.

### 5.6.11 Jointing of dissimilar metallic pipes and fittings below ground

Where ferrous and non-ferrous pipes or fittings are joined together below ground, protection against galvanic corrosion shall be provided by —

- (a) fitting a plastic connector or a short length of plastic pipe between the dissimilar metals, for threaded type joints; or
- (b) fitting an insulating gasket between flanges, insulating sleeves along the bolts, and insulating washers under the bolthead and nut, for flanged type joints.

## 5.7 Support and fixing above ground

### 5.7.1 General

Water services installed above ground shall be retained in position by brackets, clips or hangers.

### 5.7.2 Brackets, clips and hangers

Brackets, clips and hangers shall be —

- (a) formed of material compatible with pipe;
- (b) securely attached to the building structure and not to any other service;
- (c) designed to withstand the applied loads;
- (d) where exposed to a corrosive environment, protected against corrosion;
- (e) of like material or lined with a non-abrasive, inert material for that section where contact with the piping may occur;
- (f) clamped securely to prevent movement, unless designed to allow for thermal movement;
- (g) restrained to prevent lateral movement; and
- (h) installed so that no movement can occur while a valve is being operated and so that the weight of the valve is not transferred to the pipe.

### 5.7.3 Limitations of pipe supports

The following apply:

- (a) Pipes shall not be supported by brazing or welding short sections of any material to the pipe surface, or by clamping, brazing or welding to adjacent pipes.
- (b) Brackets, clips and hangers incorporating PVC shall not be used in contact with stainless steel pipes.

### 5.7.4 Spacing

Water services shall be supported and fixed at the intervals specified in [Table 5.7.4](#).

Table 5.7.4 — Spacing of brackets and clips

Nominal pipe size, DN	Maximum spacing of brackets and clips, m			
	Copper, copper alloy and stainless-steel pipes	Galvanized steel and ductile iron pipes	PVC-U, PVC-C, PVC-M, PVC-O, PE, PE-X, PP and PB pipes	
			Horizontal or graded pipes	Vertical pipes
10	1.5	—	0.50	1.00
15	1.5	2.0	0.60	1.20
16	—	—	0.60	1.20
18	1.5	—	0.60	1.20
20	1.5	2.0	0.70	1.40
22	—	—	0.70	1.40
25	2.0	2.0	0.75	1.50
32	2.5	2.5	0.85	1.70
40	2.5	2.5	0.90	1.80
50	3.0	3.0	1.05	2.10
63	—	—	1.10	2.20
65	3.0	3.0	1.20	2.40
75	—	—	1.30	2.60
80	3.0	4.0	1.35	2.70
90	3.0	—	1.40	2.80
100	3.0	4.0	1.50	3.00
110	—	—	1.50	3.00
125	3.0	4.0	1.70	3.00
140	—	—	1.70	3.40
150	3.0	4.0	2.00	4.00
160	—	—	2.00	4.00
200	3.0	4.0	2.00	4.00

NOTE Due to water pressure effects, additional brackets, clips or hangers conforming to [Clause 5.6.2](#) may be required to prevent movement.

### 5.7.5 Securing of pipes and fittings

Any pipe or fitting that may be subjected to strain or torsion shall be positively fastened against twisting or any other movement

### 5.8 Standpipes

Standpipes shall not be smaller than DN 15. They shall be connected downstream of the lower outlet bend of the water meter assembly.

All standpipes connected to the water service shall be securely supported by fixing to walls of buildings, or other rigid supports.

Standpipe taps shall be at a height of not less than 450 mm above the finished surface level or the top of a disconnector gully, as applicable.

## 5.9 Anchorage below ground

### 5.9.1 General

Water services with elastomeric (rubber) ring joints laid below ground shall be restrained by thrust blocks.

### 5.9.2 Location of thrust blocks

Thrust blocks shall be installed —

- (a) at all bends or junctions;
- (b) at the termination of piping;
- (c) at valves installed in piping;
- (d) at the reducing fitting in the direction of the smaller pipe;
- (e) at changes of direction in excess of 5°; and
- (f) at grades in excess of 1:5.

NOTE See [Figure 5.9.2](#) for typical locations of thrust blocks.

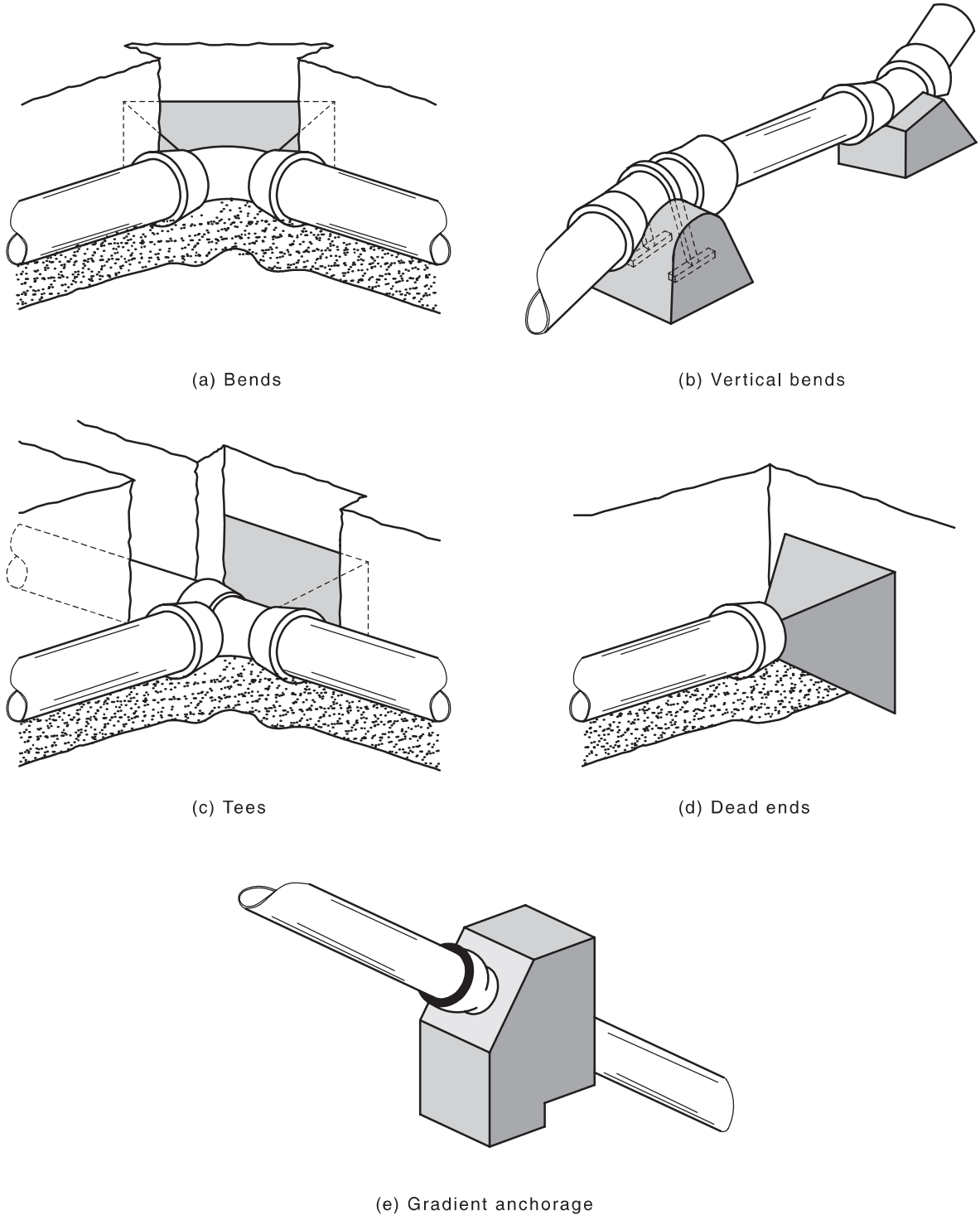

**Figure 5.9.2 — Typical locations of thrust blocks**

### 5.9.3 Construction of thrust blocks

Thrust blocks shall be —

- (a) constructed of concrete with one side bearing against a firm vertical or horizontal face of the excavation, as appropriate; and
- (b) designed so that the full hydrostatic forces in the piping are transmitted to the surrounding soil without the maximum bearing pressures of the soil and piping materials being exceeded.

Thrust blocks shall be installed such that thrust will not be transmitted to any other service.

### 5.10 Depth of cover

Where water services are installed below ground, the minimum cover shall be as specified in [Table 5.10](#), measured from the proposed finished surface levels.

**Table 5.10 — Minimum depth of cover for buried pipes**

Loading conditions	Minimum cover mm
Under slabs and footings (concrete)	75
Not subject to vehicular loading (excluding fire services)	300
Fire services not subject to vehicular loading	600
Subject to vehicular loading:	
(a) no carriageway	450
(b) sealed carriageway	600
(c) unsealed carriageway	750
Pipes in embankments or subject to construction equipment loads	750
NOTE See <a href="#">Clause 5.20</a> for minimum cover in bushfire areas.	

### 5.11 Bedding and backfill

The water services shall be surrounded with not less than 75 mm of compacted sand, or fine-grained soil, with no hard-edged object in contact with or resting against any pipe or fitting.

NOTE 1 See [Figure 5.11](#) for a typical installation.

Material used for final backfill shall be free from rock, hard matter or organic material and be broken up to contain no soil lumps larger than 75 mm.

Unless specified to the contrary, copper and stainless-steel pipelines may be installed in soil excavated from the trench in which they are to be installed, provided the soil is compatible with copper and stainless steel and free from rock and rubble.

NOTE 2 See [Clause 5.10](#) for minimum cover.

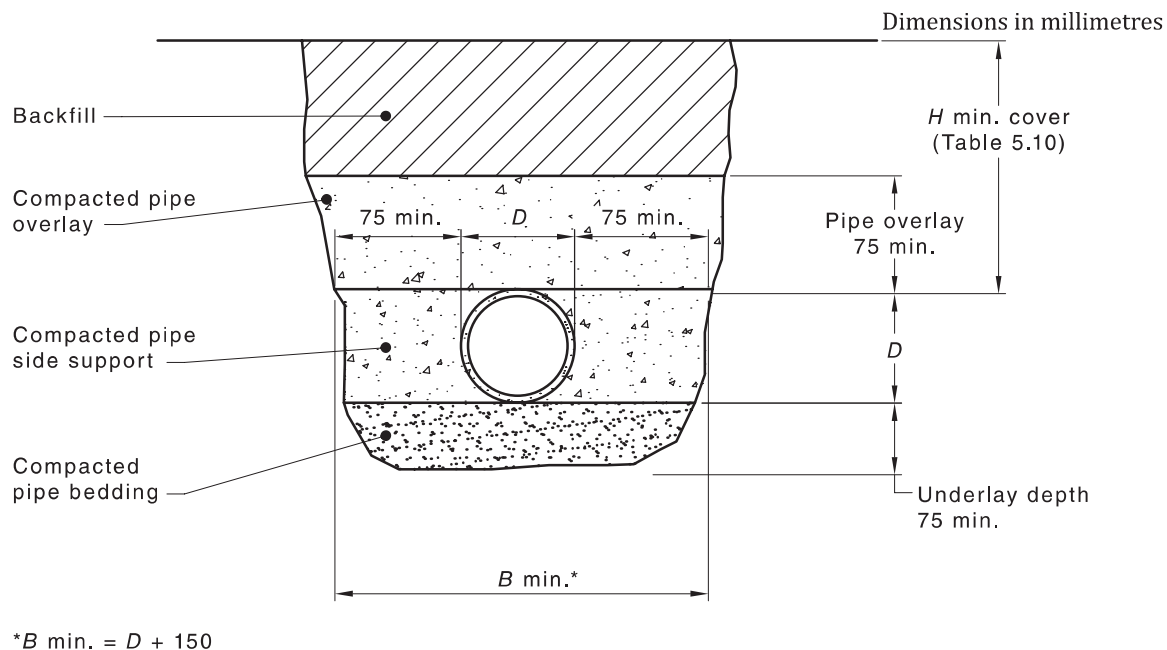

**Figure 5.11 — Typical installation in a trench**

### 5.12 Installation in contaminated areas

The installation of any water service in or through a contaminated area shall be —

- (a) laid through a watertight, corrosion-resistant conduit of sufficient length, strength and impermeability to afford adequate protection to the water service; or
- (b) fixed not less than 600 mm above the surface of the ground likely to be contaminated.

**NOTE** For the purposes of this document, contaminated areas are those that are subject to bacterial or chemical pollution. These areas include ash pits, tanks, ponds, manure bins, waste disposal depots, and wastewater treatment works.

### 5.13 Corrosive areas

Where metallic pipes, metallic fittings or Type M MLP are installed in a water service in a corrosive area, they shall be protected externally —

- (a) with an impermeable flexible plastic coating;
- (b) by placing in a sealed polyethylene sleeve; or
- (c) by continuously wrapping in a petrolatum taping material.

**NOTE** Corrosive areas are those that contain substances such as any compound consisting of magnesium oxychloride (magnesite) or its equivalent, coal wash, acid sulfate soils, sodium chloride (salt), ammonia or materials that may produce ammonia.

## 5.14 Pipes in water-charged or filled ground

When applied to water services pipes laid in water-charged or filled ground, the solutions provided in this section are applicable for pipe sizes not greater than DN 40.

NOTE As there is no Deemed to Satisfy solution for installing water pipes of DN 50 or larger in water-charged or filled ground, refer to the Plumbing Code of Australia for performance requirements.

## 5.15 Open channels or watercourses

Water services crossing any open channel or watercourse shall be installed in accordance with the requirements of the authority controlling the channel or watercourse.

## 5.16 Private easements

### 5.16.1 Proximity of water services

Where two or more water services are installed in a private easement, they shall not cross or be closer than 100 mm to each other.

### 5.16.2 Depth of piping

The depth of the pipes and fittings shall be as specified in [Table 5.10](#).

## 5.17 Dry services

Where provided for future connection to a water supply, a dry service shall conform to the following:

- (a) The ends of the dry water service shall be kept clean and sealed to prevent the entry of dirt, soil, or other matter.
- (b) Before use, the service shall be tested in accordance with [Section 17](#).

## 5.18 Protection against freezing

### 5.18.1 General

In areas where the ambient temperature regularly falls below 0 °C, care shall be taken to reduce the likelihood of the water service being damaged by water freezing within the pipes.

### 5.18.2 Piping located outside buildings

All pipes and fittings shall be —

- (a) buried to a minimum depth of 300 mm, measured from the proposed finished surface level to the top of the pipe; or
- (b) surrounded with waterproof, thermal insulation of minimum thickness, as given in [Table 5.18.2\(A\)](#).

NOTE Typical examples of insulating materials are given in [Table 5.18.2\(B\)](#).

**Table 5.18.2(A) — Minimum thicknesses for thermal insulation**

Pipe size DN	Thermal conductivity of insulating material, W/m.K				
	0.03	0.04	0.05	0.06	0.07
	Minimum thickness required, mm				
15	9	14	20	29	40
18	6	9	12	15	20
20	4	6	8	10	12
25	3	4	5	6	8
32	2	3	4	5	6

NOTE The insulation thicknesses were calculated using the equations given in BS 5422 to just prevent freezing of water initially at 15°C if exposed to an ambient temperature of -5°C for a period of 8 h.

**Table 5.18.2(B) — Typical examples of insulating materials**

Material	Thermal conductivity, W/m.K
Rockwool or fibreglass section pipe insulation (prefabricated sections)	0.032
Rockwool or fibreglass loose fill or blanket material	0.034–0.040
Flexible polyethylene foam pipe	0.032–0.045
Foamed nitrile rubber	0.040
Loose vermiculite (exfoliated)	0.06–0.07
Flexible foam plastic pre-insulated copper pipe	0.070–0.075

### 5.18.3 Pipes located on metal roofs

Pipes shall not be installed in direct contact with metal roofs. Where it is necessary to run pipework across a metal roof, it shall be surrounded with waterproof insulation of minimum thickness as specified in [Table 5.18.2\(A\)](#).

NOTE Consideration should be given to the thermal expansion and contraction of piping and the roof material.

### 5.18.4 Pipes located inside buildings

#### 5.18.4.1 General

Pipes shall be installed so as to avoid those areas of the building that are difficult to keep warm and where temperatures are likely to fall below freezing. These areas include —

- (a) unheated roof spaces;
- (b) unheated cellars;
- (c) locations near windows, ventilators or external doors where cold drafts are likely to occur; and
- (d) locations in contact with cold surfaces such as metal roofs, metal framework, or external metal cladding materials.

#### 5.18.4.2 Pipes in unheated roof spaces

Pipes in unheated roof spaces shall be located not less than 100 mm away from the roof covering and external walls.

NOTE Where practicable, pipes should be located under any insulating material laid for restricting heat losses through the ceilings.

### 5.18.4.3 Pipes adjacent to external walls

Pipes adjacent to external walls shall be positioned not less than 20 mm away from the external surface.

NOTE Where practicable, pipes should be located on the heated side of any wall insulation present.

### 5.18.5 Insulation of piping

Where it is necessary to install piping in any of the areas listed in [Clause 5.18.4.1](#), the pipes and fittings shall be surrounded by an appropriate thickness of insulation as specified in [Table 5.18.2\(A\)](#).

NOTE 1 If conditions are particularly severe over an extended time, additional thicknesses of insulation may be necessary to prevent water freezing.

NOTE 2 In situations where the building, or part of the building, is not in use over the winter months, and no interior heating of the inside areas is maintained, it may be necessary to drain the pipes to prevent damage by water freezing. For effective drainage to occur, it is essential for air to freely enter the pipes, and for all draw-off taps and float valves to be left open when draining is being carried out.

NOTE 3 See [Table 5.18.2\(B\)](#) for typical examples of insulating materials.

## 5.19 Identification of piping

Accessible pipework shall be permanently marked so as to be readily identifiable as part of the water service within:

- (a) In Australia, all Class 2 to Class 9 buildings (multi-unit, commercial and industrial buildings).
- (b) In New Zealand —
  - (i) multi-unit dwellings, including apartment buildings but excluding low rise multi-unit dwellings such as an attached dwelling or flat;
  - (ii) communal residential buildings, excluding holiday cabins and backcountry huts;
  - (iii) communal non-residential buildings;
  - (iv) commercial buildings; and
  - (v) industrial buildings.

NOTE 1 In Australia, refer to the NCC for information on building classes.

NOTE 2 In New Zealand, refer to NZBC Clause A1 Classified Uses for information on building use categories.

Identification markings shall be placed —

- (i) at spacings not exceeding 6 m;
- (ii) adjacent to branches, junctions, valves, service appliances, bulkheads, and wall and floor penetrations; and
- (iii) at every floor level within vertical ducts and riser cupboards.

NOTE 3 Refer to AS 1345 for information on identification tags and labels in Australia.

NOTE 4 Refer to NZS 5807 for information on identification marking in New Zealand.

## 5.20 Temperature control devices

Temperature control devices shall be installed in accordance with AS/NZS 3500.4.

## 5.21 Australian bushfire prone areas

NOTE The NCC outlines requirements for plumbing in designated bushfire prone areas.

## Section 6 Fire services

### 6.1 Scope of section

This section specifies requirements for the installation of fire hydrants, fire hose reels, fire sprinkler services and independent wall drencher systems downstream of the backflow prevention device fitted, where required, to a water supply system.

NOTE 1 For direction as to when a fire service is required, refer to NCC Volumes One or Two (BCA) or the New Zealand Building Code.

NOTE 2 Backflow prevention devices are generally installed at the property boundary and may also be located inside the property.

### 6.2 Materials and products

Materials and products used in fire service installations shall be subject to the limits on the use of the material or product specified in [Section 2](#) and the relevant Standard covering the fire service.

NOTE Some authorities have additional limitations on the use of certain materials.

### 6.3 Installation

Fire service piping shall be installed in accordance with [Section 5](#) and the relevant fire system Standard.

Backflow prevention shall be installed in accordance with [Section 4](#).

NOTE 1 For further information related to fire services refer to the following Standards:

- (a) AS 2118 (parts 1 2, 3, 4 and 6) — automatic fire sprinkler systems.
- (b) AS 2419 (part 1) — fire hydrant installations.
- (c) AS 2441 — installation of fire hose reels.
- (d) AS 2941 — fixed fire protection installations.
- (e) NZS 4510 — fire hydrant systems for buildings.
- (f) NZS 4515 — fire sprinkler systems in sleeping occupancies.
- (g) NZS 4541 — automatic fire sprinkler systems.
- (h) AS 2118.5 — automatic fire sprinkler systems - Home sprinkler systems; or NZS 4517 — fire sprinkler systems for houses.

NOTE 2 NCC Volume Three (PCA) outlines the requirements for firefighting water services.

### 6.4 Water storage tanks

Water storage tanks shall be installed in accordance with [Section 8](#). Where a tank provides a reservoir of water in case of a fire, the tank shall not be bypassed unless a backflow prevention device appropriate to the cross-connection hazard rating is installed in the bypass piping.

NOTE Refer to the appropriate regulatory authority for minimum water storage requirements for fire services.

### 6.5 Identification

Fire service pipelines shall be identified in accordance with AS 1345 or NZS 5807, as appropriate.

## Section 7 Irrigation and lawn watering systems

### 7.1 Scope of section

This section sets out requirements for and defines the types of irrigation systems for the purposes of backflow prevention.

### 7.2 System types

Irrigation systems including hose tap connected systems shall be categorized as one of the following types:

- (a) *Type A systems* — All permanently open outlets and piping more than 150 mm above finished ground level, not subject to ponding or back-pressure and not involving injection systems. No backflow prevention required, see [Figure 7.2\(A\)](#).
- (b) *Type B systems* — Irrigation systems in domestic or residential buildings with piping or outlets installed less than 150 mm above finished surface level and not involving injection systems, see [Figures 7.2\(B\)](#) and [7.2\(C\)](#).
- (c) *Type C systems* — Irrigation systems in other than domestic or residential buildings with piping or outlets less than 150 mm above finished surface level and not involving injection systems, see [Figures 7.2\(D\)](#) and [7.2\(E\)](#).
- (d) *Type D systems* — Irrigation system where fertilizers, herbicides, nematicides or the like are injected or siphoned into the system, see [Figures 7.2\(F\)](#) and [7.2\(G\)](#).

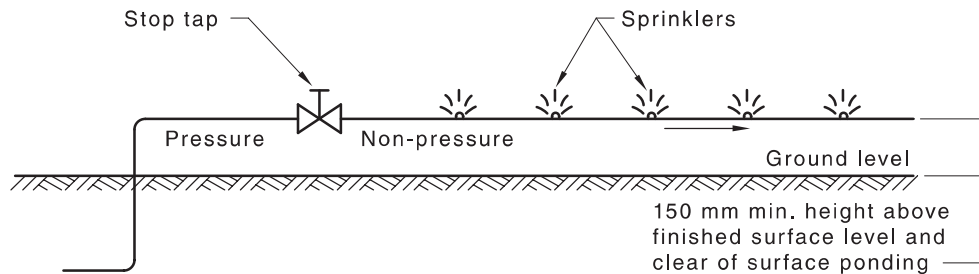

**Figure 7.2(A) — Type A system — No backflow prevention required**

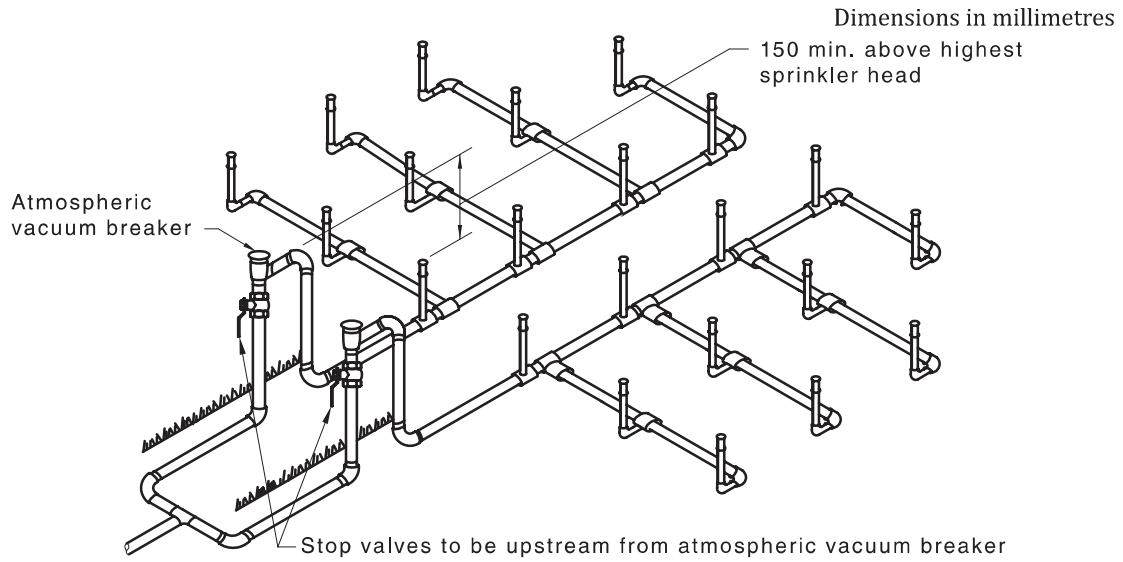

(i) Level terrain—Multi-zone system using atmospheric vacuum breaker

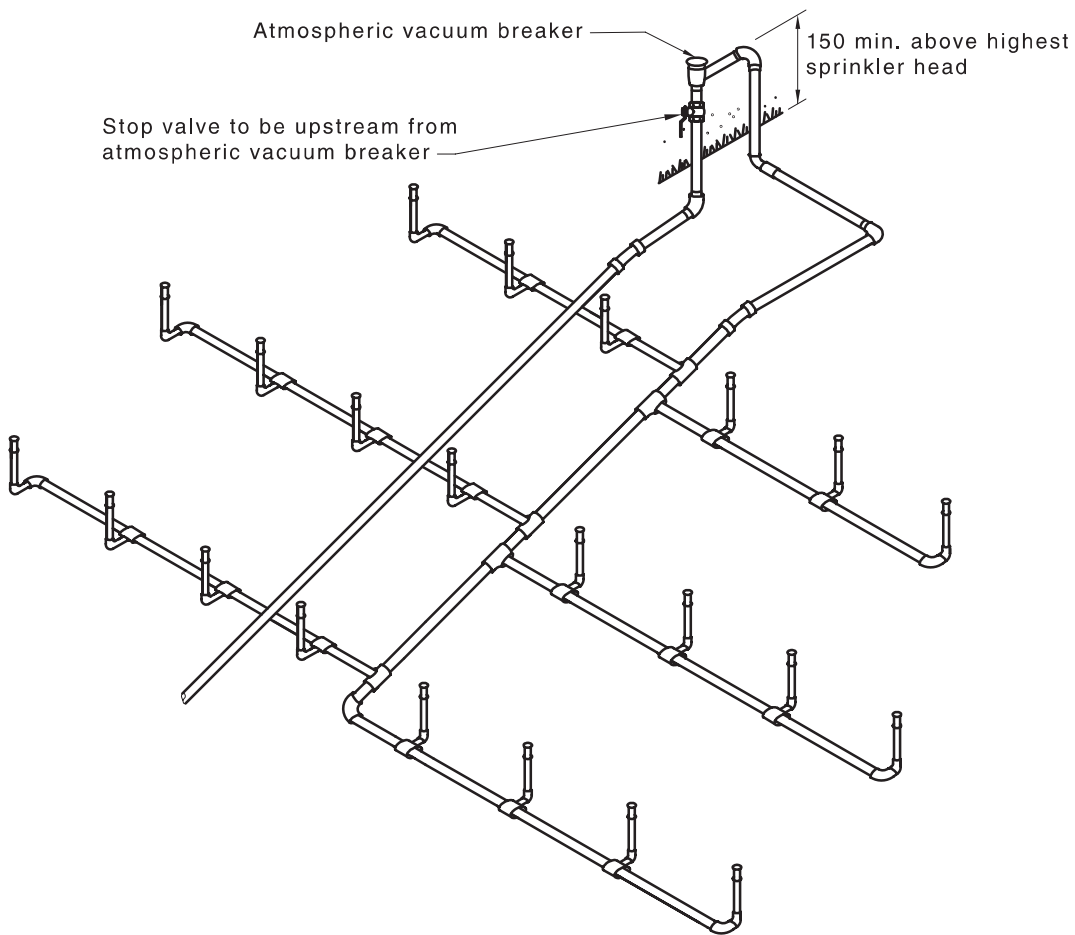

(ii) Hillside system using atmospheric vacuum breaker

**Figure 7.2(B) — (1 of 2) — Type B system — Non-testable devices — No back-pressure**

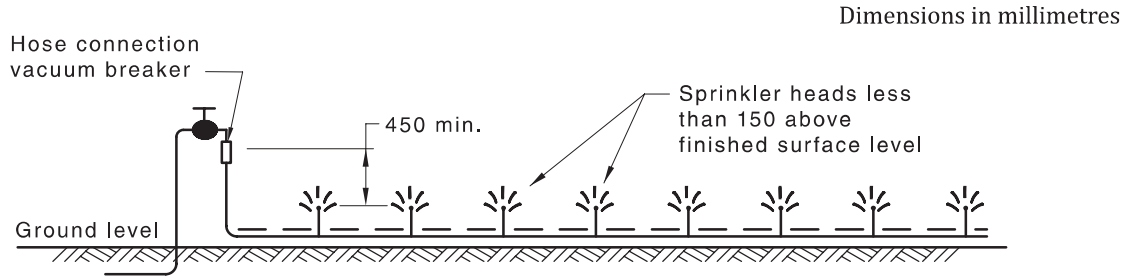

(iii) System using hose connection vacuum breaker

**Figure 7.2(B) — (2 of 2) — Type B system — Non-testable devices — No back-pressure**

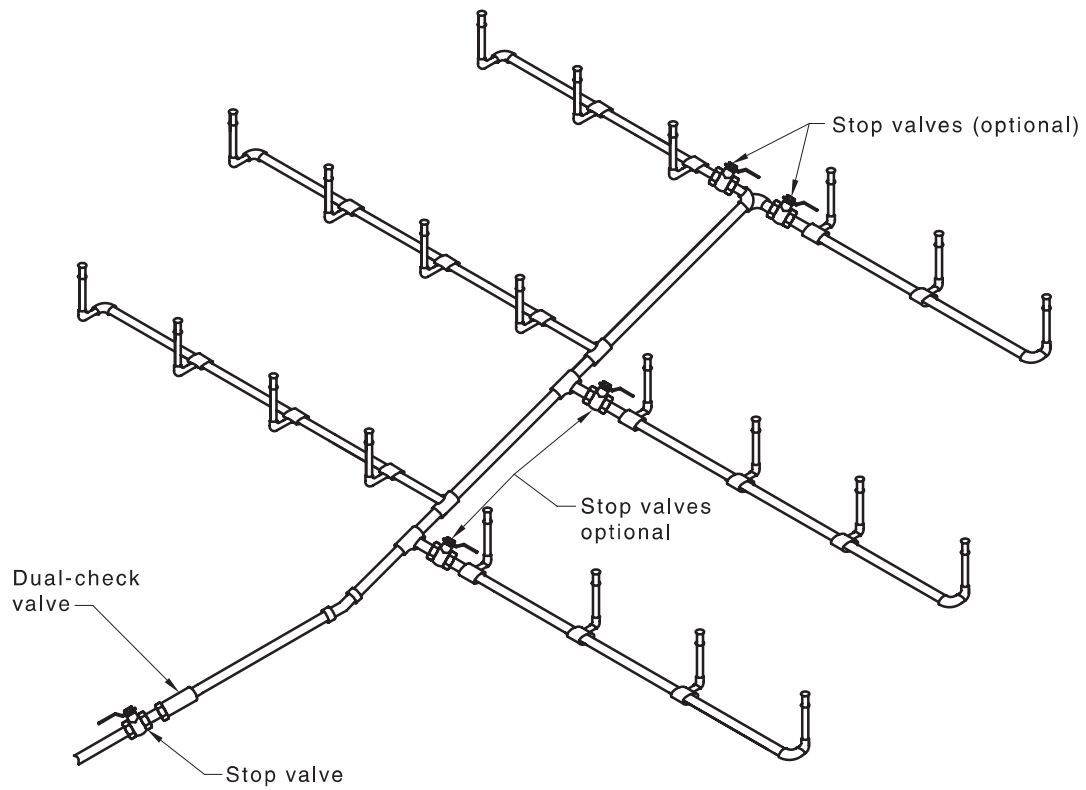

**Figure 7.2(C) — Type B system — Non-testable devices — Suitable for back-pressure**

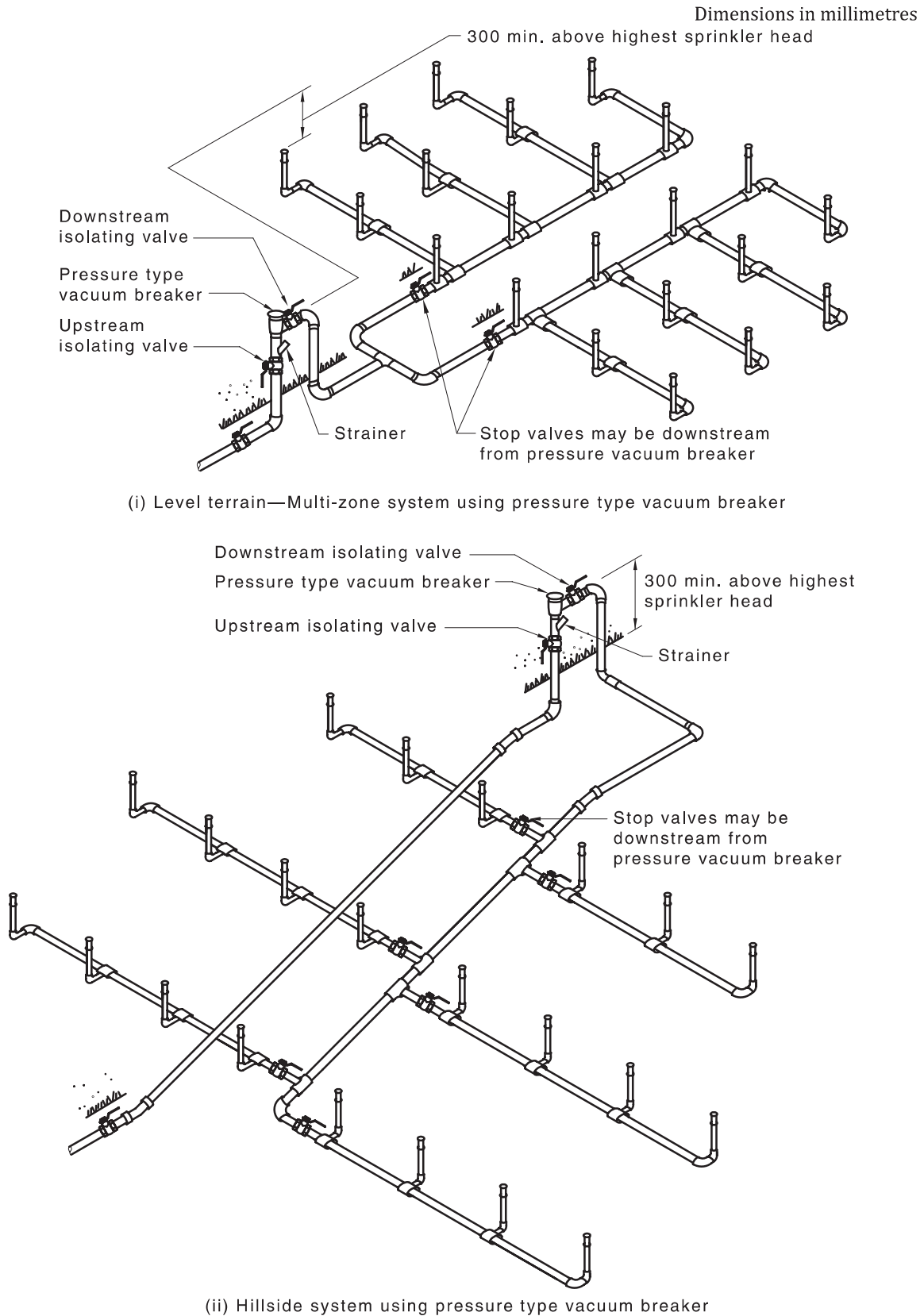

**Figure 7.2(D) — Type C system — Testable devices — No back-pressure**

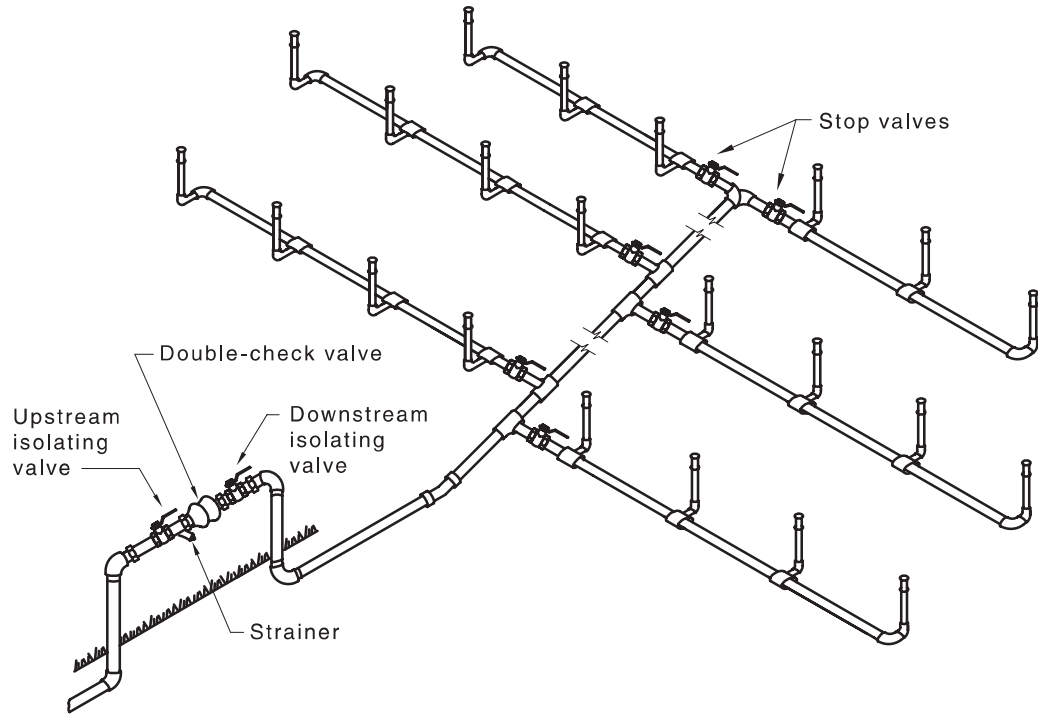

**Figure 7.2(E) — Type C system — Testable devices subject to back-pressure or no back-pressure for hillside or multi-zone system — Double check valve assembly**

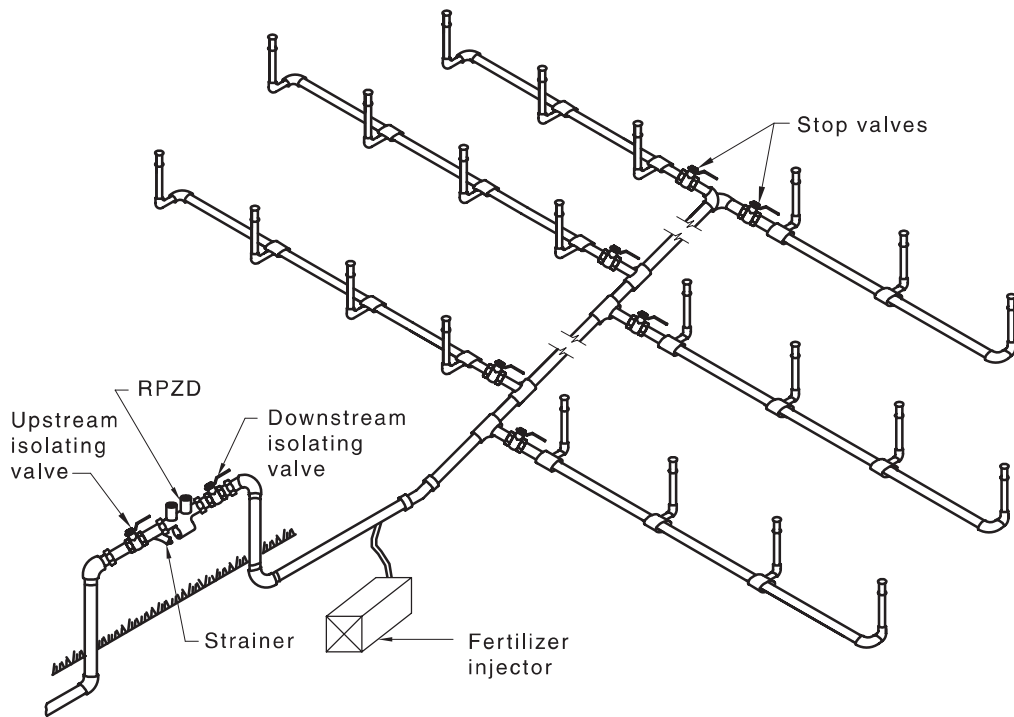

**Figure 7.2(F) — Type D system — Testable devices subject to back-pressure or no back-pressure for applications with chemical additives — Reduced pressure zone device**

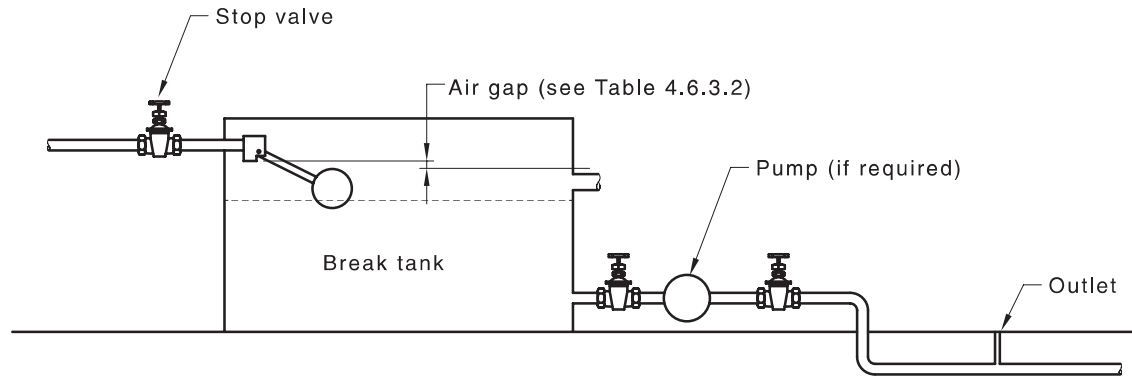

**Figure 7.2(G) — Type D system — Typical irrigation supply through a registered break tank**

### 7.3 Backflow protection requirements

Type B, Type C and Type D irrigation systems shall be protected against backflow.

NOTE See [Table F.1](#) and [Figures 7.2\(A\) to 7.2\(G\)](#), as applicable, for examples.

### 7.4 Materials

All materials, valves and fittings on the upstream side of, and including the last pressurized valve on each line, shall be as specified in [Section 2](#).

## Section 8 Water storage tanks

### 8.1 Scope of section

This section specifies requirements for water storage tanks.

NOTE See [Section 15](#) for connections of rainwater tanks.

### 8.2 Purpose of tanks

#### 8.2.1 General

This section applies to tanks provided for the storage of water for the following purposes:

- (a) Sanitary flushing.
- (b) Drinking water supply.
- (c) Firefighting.
- (d) Air-conditioning.
- (e) Refrigeration.
- (f) Ablutions.
- (g) Prevention of cross-connections.
- (h) Make-up water.
- (i) Contingency reserve.

#### 8.2.2 Limitations on use

A tank that is intended for the storage of drinking water shall not be used to supply directly any water closet pan, bidet, flush valve, slop hopper pan or other similar fixture or fitting used, or intended to be used, for sanitary flushing, except as provided for in [Clause 11.9](#).

### 8.3 Design and installation requirements

#### 8.3.1 General

The installation of tanks shall be as follows:

- (a) Materials used to construct tanks shall be as specified in [Section 2](#).
- (b) All tanks shall be installed on bases, plinths or supports designed to adequately support the weight of any such tank and its contents when filled to maximum capacity.
- (c) All metallic tanks or such other tanks as may be directed shall be installed with a membrane of non-corrosive insulating material between the support and the underside of the tank.
- (d) Every tank shall be supported in such a manner that no load is transmitted to any of the attached pipes.
- (e) All tanks shall be accessible for inspection, repairs, maintenance and replacement.
- (f) Every tank shall be provided with a cover that is designed to prevent the entry of dust, roof water, surface water, groundwater, and bird or animal life.

- (g) For New Zealand, tanks shall be seismically restrained against movement in accordance with NZS 4219 or NZBC Acceptable Solution G12/AS1 to comply with NZBC Clause B1 Structure.

### 8.3.2 Capacity of storage tanks — Measurement

The storage capacity of any tank shall be taken to be the volume of water above the invert of the outlet pipe when the water surface is 20 mm below overflow level.

### 8.3.3 Access

Headroom and side access shall be provided for every tank to enable inspection, cleaning and maintenance procedures to be carried out to the interior and exterior of the tank.

Where the interior depth of any storage tank exceeds 2 m, access ladders shall be installed.

NOTE 1 Refer to AS 2865 for information on confined spaces.

NOTE 2 Refer to AS 1657 for information on the design, construction and installations of fixed platforms, walkways, stairways and ladders.

### 8.3.4 Placement of tank

#### 8.3.4.1 Safe-tray

Where required, tanks shall be placed in safe-trays in accordance with [Clause 8.8](#).

#### 8.3.4.2 Limitations on location of drinking water tanks

Tanks storing drinking water shall not be located directly beneath any sanitary plumbing or any other pipes conveying non-drinking water.

## 8.4 Tank design

### 8.4.1 General

Water storage tanks shall be designed and connected in accordance with [Figure 8.4.1](#). Tanks with dual water supply shall maintain the air gap in accordance with [Clause 4.6.3.2\(a\)](#). Where the capacity exceeds 500 L, provision shall be made at the base for removal of sludge.

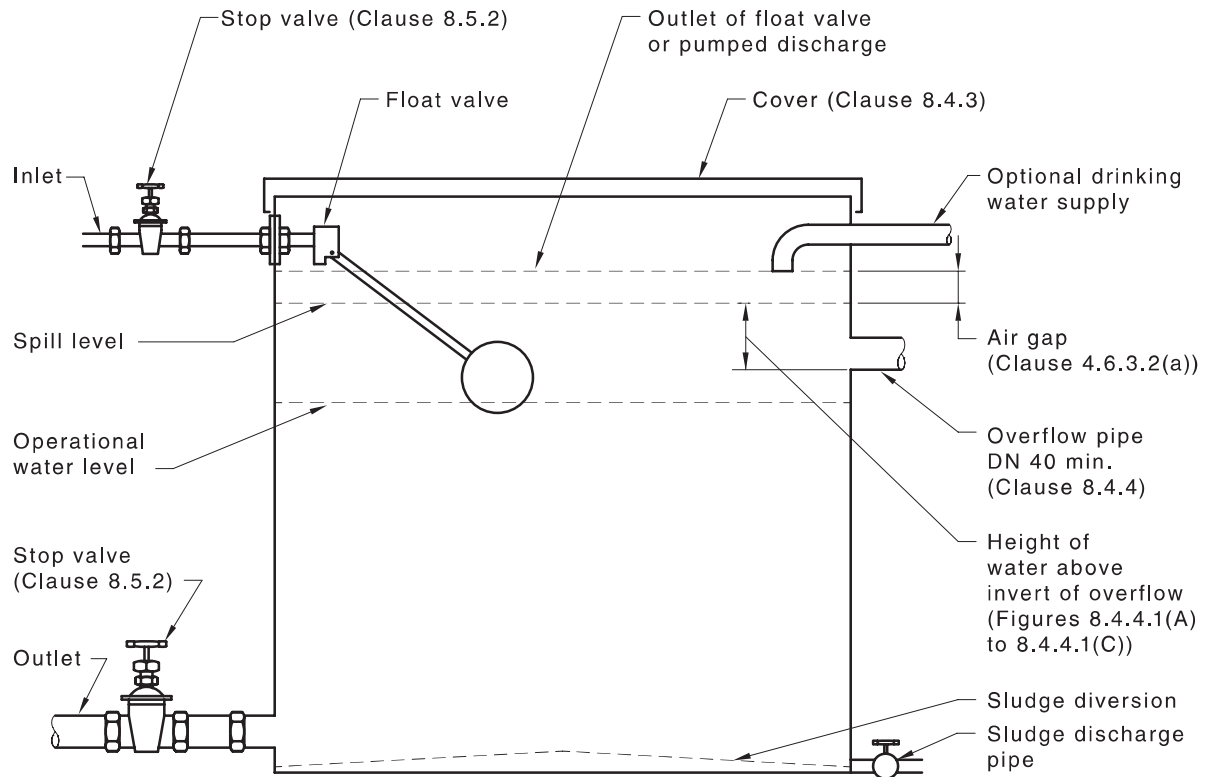

Figure 8.4.1 — Cold water storage tank

### 8.4.2 Internal corrosion protection

Where required for corrosion protection, the internal surfaces of tanks shall be coated with a protective coating.

### 8.4.3 Tank cover

Any tank that supplies drinking water shall be provided with a cover that is —

- (a) close fitting; and
- (b) secured in position if the tank is located externally.

Where the whole cover is not removable, the tank shall be provided with a covered access opening not smaller than 0,5 m<sup>2</sup>.

### 8.4.4 Tank overflow

#### 8.4.4.1 General

Overflow pipes from tanks shall be —

- (a) not smaller than DN 40; and
- (b) capable of discharging the inflow rates given in [Table 8.4.4.1](#) and the outflow rates specified in [Figures 8.4.4.1\(A\)](#), [8.4.4.1\(B\)](#) and [8.4.4.1\(C\)](#) or hydraulically calculated, taking into account the maximum head available in the main (but not less than 500 kPa), friction losses, elevation of the tank, size of the orifice and type of overflow outlet.

**Table 8.4.4.1 — Rate of inflow to storage tanks**

Diameter of float valve inlet orifice mm	Inflow at 500 kPa L/s
6	0.54
8	0.95
10	1.49
15	3.4
20	6.0
25	9.3
32	15.3
40	23.8
50	37.2 <sup>a</sup>
65	63.0
80	95.4
100	149.0
125	232.8
150	335.2

<sup>a</sup> [Figures 8.4.4.1\(A\), 8.4.4.1\(B\)](#) and [8.4.4.1\(C\)](#) only cover up to this inflow.

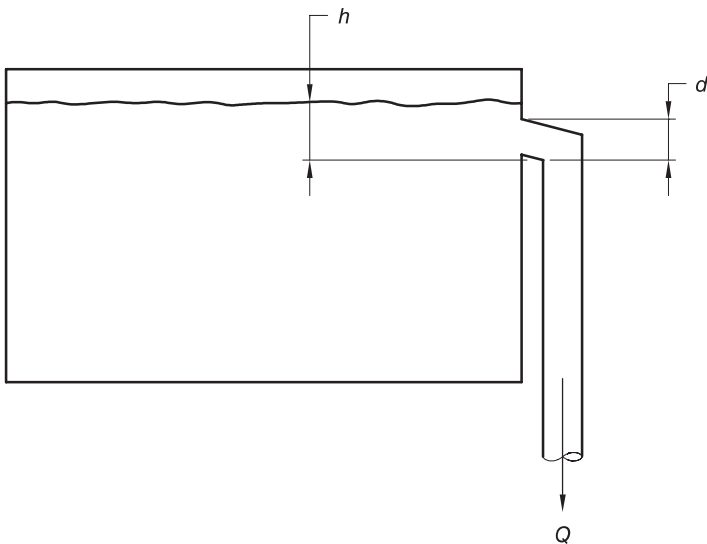

Flow rates shall be determined from the following equations:

Weir flow,  $h \leq d$   $Q = 4.66 \times 10^{-5} \times d^{0.7} \times h^{1.8}$  8.4.4.1(1)

Orifice flow,  $h > d$   $Q = 6.6 \times 10^{-5} \times d^2 \times \sqrt{\left(h - \frac{d}{2}\right)}$  8.4.4.1(2)

Internal diameter of overflow pipe ( <i>d</i> ) mm	Discharge through overflow ( <i>Q</i> ), L/s									
	Height of water above invert of overflow ( <i>h</i> ), mm									
	20	30	40	50	75	100	125	150	175	200
40	0.14	0.28	0.47	0.58	0.78	0.94	1.08	1.20	1.31	1.42
50	0.16	0.33	0.55	0.83	1.17	1.43	1.65	1.84	2.02	2.18

Internal diameter of overflow pipe ( <i>d</i> ) mm	Discharge through overflow ( <i>Q</i> ), L/s									
	Height of water above invert of overflow ( <i>h</i> ), mm									
	20	30	40	50	75	100	125	150	175	200
75	0.21	0.44	0.73	1.09	2.27	2.93	3.47	3.94	4.35	4.73
100	0.26	0.53	0.90	1.34	2.78	4.67	5.72	6.60	7.38	8.08
125	0.30	0.62	1.05	1.56	3.25	5.45	8.15	9.65	10.94	12.09
150	0.34	0.71	1.19	1.78	3.69	6.19	9.25	12.86	14.85	16.60
175	0.38	0.79	1.33	1.98	4.11	6.89	10.30	14.30	18.91	21.44
200	0.42	0.87	1.45	2.17	4.51	7.57	11.31	15.71	20.73	26.40

NOTE The orifice coefficient  $m = 0.6$  applies to the orifice flow conditions. Water heights are measured from the pipe invert or crest. This allows for overflows that are not flowing full. The capacity of those overflows is determined from the minimum specific energy of flow over a weir. No allowance is given in the Table for bellling of the overflow, nor for an increase in effective head due to siphonage through the overflow pipe. These factors may substantially increase the discharge capacity of the overflow pipe.

Figure 8.4.4.1(A) — Rate of outflow from Type 1 overflow (piped) horizontal outlet storage tanks

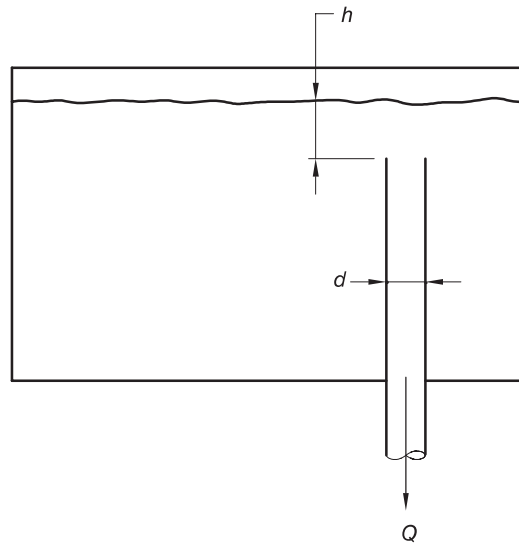

Flow rates shall be determined from the following equations:

$$\text{Weir flow, } h \leq \frac{d}{3} \quad Q = 1.98 \times 10^{-4} \times d \times h^{1.5} \quad 8.4.4.1(3)$$

$$\text{Orifice flow, } h > \frac{d}{3} \quad Q = 6.60 \times 10^{-5} \times d^2 \times \sqrt{h} \quad 8.4.4.1(4)$$

Internal diameter of overflow pipe ( <i>d</i> ) mm	Discharge through overflow ( <i>Q</i> ), L/s									
	Height of water above invert of overflow ( <i>h</i> ), mm									
	20	30	40	50	75	100	125	150	175	200
40	0.47	0.58	0.67	0.75	0.91	1.06	1.18	1.29	1.40	1.49
50	0.74	0.90	1.04	1.17	1.43	1.65	1.84	2.025	2.18	2.33
75	1.33	2.03	2.35	2.63	3.22	3.71	4.14	4.55	4.91	5.25

Internal diameter of overflow pipe ( <i>d</i> ) mm	Discharge through overflow ( <i>Q</i> ), L/s									
	Height of water above invert of overflow ( <i>h</i> ), mm									
	20	30	40	50	75	100	125	150	175	200
100	1.77	3.25	4.17	4.67	5.72	6.60	7.38	8.08	8.73	9.33
125	2.21	4.07	6.26	7.29	8.93	10.31	11.53	12.63	13.64	14.58
150	2.66	4.88	7.51	10.50	12.86	15.84	16.60	18.19	19.64	21.00
175	3.10	5.69	8.77	12.25	17.50	20.21	22.60	24.76	26.74	28.58
200	3.54	6.51	10.02	14.00	22.86	26.40	29.52	32.33	34.92	37.34

NOTE The orifice coefficient  $m = 0.6$  applies to the orifice flow conditions. Water heights are measured from the pipe invert or crest. This allows for overflows that are not flowing full. The capacity of those overflows is determined from the minimum specific energy of flow over a weir. No allowance is given in the Table for bellling of the overflow, nor for an increase in effective head due to siphonage through the overflow pipe. These factors may substantially increase the discharge capacity of the overflow pipe.

Figure 8.4.4.1(B) — Rate of outflow from type 2 overflow (piped) vertical outlet storage tanks

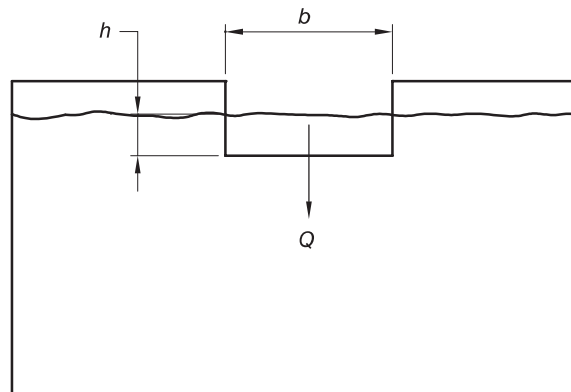

Flow rates shall be determined from the following equations:

$$\text{Weir flow} \quad Q = 5.39 \times 10^{-5} \times b \times h^{1.5} \quad 8.4.4.1(5)$$

Internal diameter of overflow pipe ( <i>d</i> ) mm	Discharge through overflow ( <i>Q</i> ), L/s									
	Height of water above invert of overflow ( <i>h</i> ), mm									
	20	30	40	50	75	100	125	150	175	200
25	0.12	0.22	0.34	0.48	0.88	1.35	1.88	2.48	3.12	3.81
30	0.14	0.27	0.41	0.57	1.05	1.62	2.26	2.97	3.74	4.57
75	0.36	0.66	1.02	1.43	2.63	4.04	5.65	7.43	9.36	11.43
100	0.48	0.89	1.36	1.91	3.50	5.39	7.53	9.90	12.48	15.25
125	0.60	1.11	1.70	2.38	4.38	6.74	9.42	12.38	15.60	19.06
150	0.72	1.33	2.05	2.86	5.25	8.08	11.30	14.85	18.72	22.87
175	0.84	1.55	2.39	3.33	6.13	9.43	13.18	17.33	21.84	26.68
200	0.96	1.77	2.73	3.81	7.00	10.78	15.07	19.80	24.96	30.49

Internal diameter of overflow pipe ( <i>d</i> ) mm	Discharge through overflow ( <i>Q</i> ), L/s									
	Height of water above invert of overflow ( <i>h</i> ), mm									
	20	30	40	50	75	100	125	150	175	200
NOTE The orifice coefficient $m = 0.6$ applies to the orifice flow conditions. Water heights are measured from the pipe invert or crest. This allows for overflows that are not flowing full. The capacity of those overflows is determined from the minimum specific energy of flow over a weir. No allowance is given in the Table for bellling of the overflow, nor for an increase in effective head due to siphonage through the overflow pipe. These factors may substantially increase the discharge capacity of the overflow pipe.										

**Figure 8.4.4.1(C) — Rate of outflow from type 3 overflow (weir) rectangular outlet storage tanks**

#### 8.4.4.2 Discharge of overflow

In order not to cause damage or nuisance, the tank overflow shall discharge where it is readily visible —

- into the safe-tray, directly over the safe-tray overflow outlet;
- directly into the safe-tray overflow;
- onto an impervious graded floor, in such manner that the entire discharge drains freely and harmlessly to a floor waste outlet; or
- outside the building, clear of doors, windows or other opening, and within the property boundaries.

The supply rate shall be determined from the following equation:

$$Q = m \times A \times \sqrt{2gH} \times 10^3 \quad 8.4.4.2$$

where

- $Q$  = supply rate, in litres per second
- $m$  = orifice coefficient for thin sharp-edged plate  
= 0.6
- $A$  = cross-sectional area of orifice, in square metres
- $g$  = acceleration due to gravity (9.8 m/s<sup>2</sup>)
- $H$  = head of water on inlet of orifice, in metres

NOTE 1 The diameter of the float valve inlet orifice is not necessarily related to the nominal size of the fitting.

NOTE 2 As a guide, the orifice size is normally half the nominal size, except in the case of full way valves.

NOTE 3 See [Appendix G](#) for an example of calculation of overflow rate.

#### 8.4.4.3 Discharge not readily visible

Where the tank overflow pipe does not discharge to a readily visible position, a telltale pipe not smaller than DN 20 shall be connected to the invert of the overflow pipe and discharge as required by [Clause 8.4.4.2](#).

#### 8.4.4.4 Size of air gap

An air gap conforming to [Clause 4.6.3.2\(a\)](#) shall be maintained between the spill level of the tank and the outlet of the water service.

### 8.5 Inlet piping

#### 8.5.1 Connections

Union couplings or flanges shall be used to connect the water service to the inlet of the storage tank.

#### 8.5.2 Stop valve

Where a float valve is fitted, an isolating valve shall be installed in an accessible position to allow maintenance of the float valve.

### 8.6 Outlet piping

#### 8.6.1 Connections

The outlet piping shall be connected to the storage tank by means of union couplings or flanges. The outlet piping shall be a minimum of one pipe diameter from the bottom of the tank.

#### 8.6.2 Service outlets

For tanks of more than 50 L capacity, each service outlet shall be fitted with an isolating valve installed in an accessible location.

### 8.7 Sludge valves

A sludge valve shall be fitted where the capacity of the tank exceeds 500 L. The minimum size of the valve shall be not less than half the outlet pipe size nor less than DN 40.

### 8.8 Safe-tray

#### 8.8.1 General

A safe-tray shall be provided under every storage tank. Where the tank is external to the building or located on an impervious floor graded to an outlet, the safe-tray shall —

- (a) have no portion of the tank closer than 75 mm to a vertical line from the edge of the safe-tray and no portion of an attached auxiliary part closer than 25 mm to such vertical line; and
- (b) have placed, between the tank and the safe-tray, durable supports not less than 12 mm thick and of an area not less than  $0.5A$  and up to  $0.6A$  (where  $A$  is the area of the base of the tank). The support shall project beyond the sides and walls of the tank but not closer than 20 mm to the sides of the safe-tray.

#### 8.8.2 Safe-tray construction

Safe-trays shall be fabricated from materials specified in [Clause 2.5](#). The sides of trays shall be not less than 50 mm in height and all joints shall be made watertight.

### 8.8.3 Overflow

The safe-tray shall be fitted with an overflow that effectively drains the safe-tray. The overflow drain shall have —

- (a) an internal diameter greater than the diameter of the tank overflow, but not less than DN 50 in Australia and DN 40 in New Zealand;
- (b) a continuous fall to its discharge point in accordance with [Clause 8.4.4.2](#);
- (c) all seams in sheet metal pipe uppermost;
- (d) all joints in sheet metal pipe lapped in the direction of the flow;
- (e) all circumferential joints made watertight; and
- (f) support in the vicinity of the tray and at intervals not greater than 1 m horizontally and 2.4 m vertically.

### 8.9 Marking of tanks

Except if installed in domestic or residential buildings, all tanks shall have their intended use identified with not less than two permanent notices attached to each tank in visible positions, one on the front of the tank and one on the cover.

NOTE In Australia, domestic or residential buildings are Class 1 buildings as defined by the NCC.

Notices shall —

- (a) be not less than 450 mm × 250 mm in size;
- (b) have a red background; and
- (c) have the text in white, capital letters of not less than 25 mm in height.

Tanks holding drinking water shall carry the following warning:

**WARNING — DRINKING WATER**

## Section 9 Non-drinking water services

### 9.1 Scope of section

This section specifies the design, installation and maintenance requirements for non-drinking water services, including recycled and reclaimed water from the point of connection to the point of discharge.

NOTE 1 See [Figure 9.1](#) for a typical layout of a non-drinking water installation.

NOTE 2 Non-drinking water is any water that is not fit for human consumption, as determined by the health authority or authority having jurisdiction.

NOTE 3 NCC Volume Three (PCA) outlines the limitations for the use of non-drinking water.

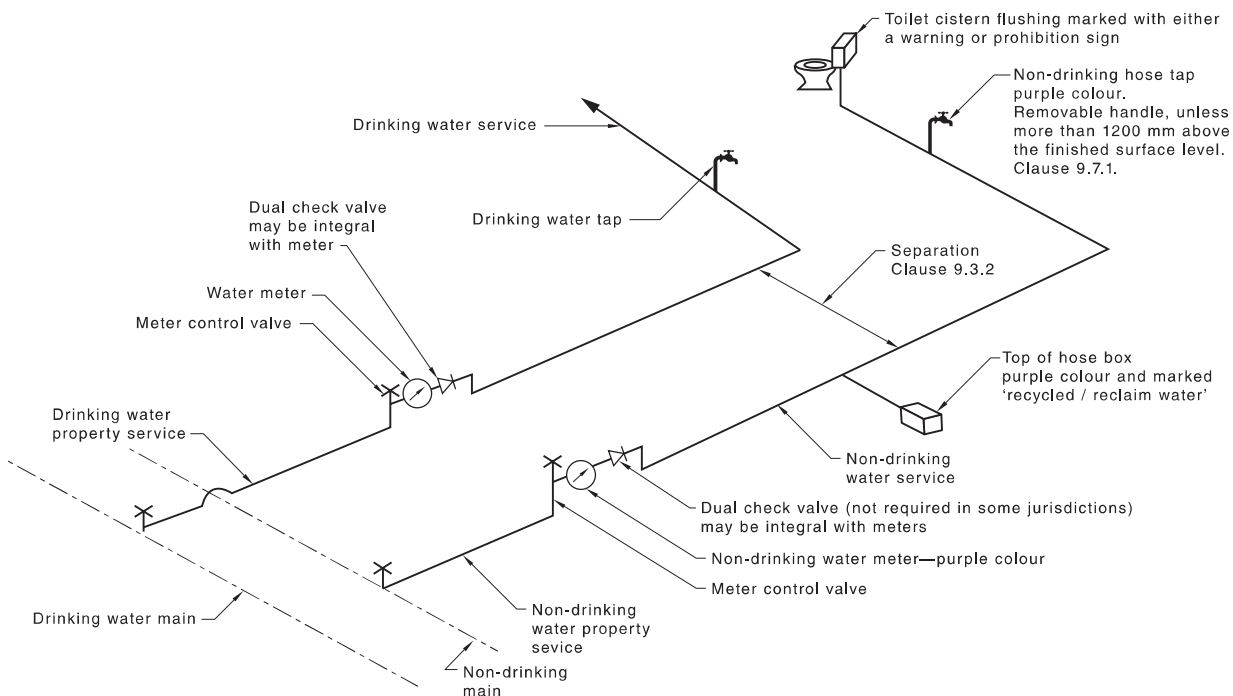

**Figure 9.1 — Typical non-drinking water installation from a reticulated non-drinking water system**

### 9.2 Materials and products

#### 9.2.1 General

Materials and products used in the installation of non-drinking water services shall be as specified in [Section 2](#).

NOTE Refer to AS 2700 for information on reference colours.

#### 9.2.2 Water meters

Water meters shall be —

- permanently coloured purple, not darker than Jacaranda P24 or Purple P12 and not lighter than Lilac P23; and
- installed in an accessible position.

NOTE The meter inlet and outlet threads may be different to prevent interchange with the drinking water meter.

### 9.3 Installation requirements

#### 9.3.1 Installation

Installation shall be in accordance with the requirements for drinking water.

#### 9.3.2 Proximity to other services

##### 9.3.2.1 Above-ground installations

Above-ground non-drinking water services shall be installed —

- (a) a minimum of 25 mm from any parallel drinking water service; or
- (b) in a duct or structurally separated.

##### 9.3.2.2 Below-ground installations

Below-ground non-drinking water services shall be installed —

- (a) a minimum of 300 mm from any parallel drinking water service; and
- (b) a minimum of 100 mm from any other non-drinking water service.

NOTE Below-ground installation refers to non-drinking water services buried in the ground.

### 9.4 Cross-connection control

There shall be no cross-connection between any drinking or non-drinking water services.

### 9.5 Temporary bypass

Where a building or property is intended to have a non-drinking water service connected but has not yet had that service provided, a bypass line may be installed provided it shall —

- (a) be temporary during construction of the building or until the non-drinking water is available;
- (b) be located downstream of the meter or property boundary;
- (c) incorporate an isolation valve at the connection to the drinking water service; and
- (d) be in an accessible location.

NOTE See [Figure 9.5](#) for a typical example of a temporary bypass.

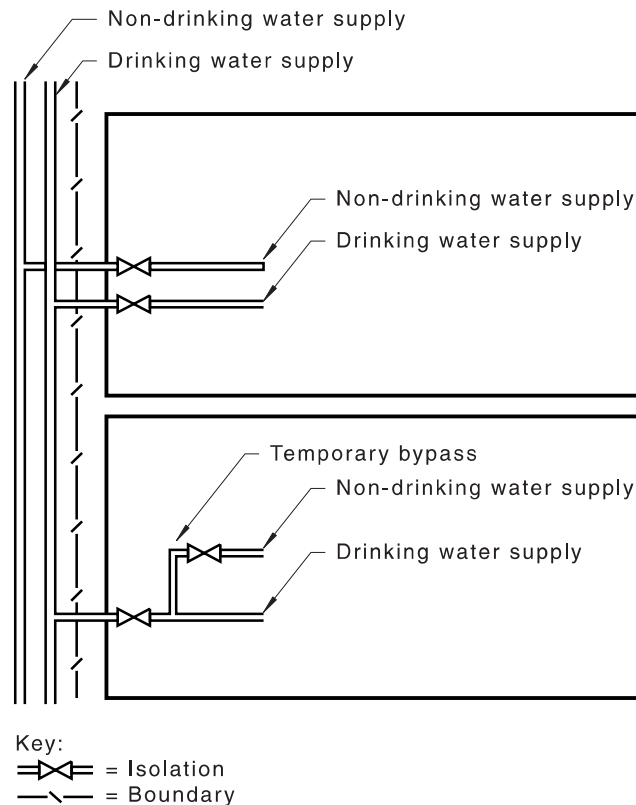

Figure 9.5 — Typical example of a temporary non-drinking water bypass

## 9.6 Identification of non-drinking water services

### 9.6.1 Colour of non-drinking water pipework

Non-drinking water service pipework shall be a purple colour not darker than P24 Jacaranda or P12 Purple and not lighter than P23 Lilac.

Where pipes are not coloured purple, identification may be achieved by means of close-fitting durable purple-coloured sleeving, netting or spirally wrapped tape.

NOTE 1 Refer to AS 2700 for information regarding reference colours.

NOTE 2 It is not necessary to use purple coloured fittings.

### 9.6.2 Marking of non-drinking water pipework

Accessible pipework shall be permanently marked so as to be readily identifiable as part of the non-drinking water service within:

- (a) In Australia, all Class 2 to Class 9 buildings (multi-unit, commercial and industrial buildings).
- (b) In New Zealand —
  - (i) multi-unit dwellings, including apartment buildings but excluding low rise multi-unit dwellings such as an attached dwelling or flat;
  - (ii) communal residential buildings, excluding holiday cabins and backcountry huts;
  - (iii) communal non-residential buildings;

- (iv) commercial buildings; and
- (v) industrial buildings.

NOTE 1 In Australia, refer to the NCC for information on building classes

NOTE 2 In New Zealand, refer to NZBC Clause A1 Classified Uses for information on building use categories.

Identification markings shall be placed —

- (i) at spacings not exceeding 6 m;
- (ii) adjacent to branches, junctions, service appliances, bulkheads and wall and floor penetrations; and
- (iii) at every floor level within vertical ducts and riser cupboards.

NOTE 3 Pipes which are coloured as part of the manufacturing process are acceptable.

NOTE 4 Refer to AS 1345 for information on identification marking in Australia.

NOTE 5 Refer to NZS 5807 for information on identification marking in New Zealand.

### 9.6.3 Identification of buried non-drinking water services

Buried pipes shall be identified with purple coloured underground marking tape.

### 9.6.4 Installation of underground marking tape

Underground marking tape shall —

- (a) conform to AS/NZS 2648.1; and
- (b) be installed on top of the pipe, running longitudinally, fastened to the pipe at not more than 3 m intervals and state the following:

#### **RECYCLED OR RECLAIMED WATER — DO NOT DRINK**

Non-drinking water for irrigation, installed above the service, shall be marked with the following:

#### **THE PIPE BELOW IS NON-DRINKING WATER**

## 9.7 Non-drinking water outlets

### 9.7.1 External non-drinking hose tap outlets

External non-drinking water hose tap outlets shall —

- (a) have a removable handle, except where the outlet is installed 1 200 mm or more above the finished surface level;
- (b) be permanently coloured purple, not darker than Jacaranda P24 or Purple P12 and not lighter than Lilac P23; and
- (c) have standard threads on the inlet and outlet.

NOTE Refer to AS 2700 for information on reference colours.

### 9.7.2 Identification of all non-drinking water outlets

All non-drinking water outlets shall be clearly and permanently marked with —

- (a) a warning sign as shown in [Figure 9.7.2\(A\)](#); or
- (b) a prohibition sign.

NOTE 1 Refer to AS 1319 for information on safety signs for the occupational environment.

NOTE 2 See [Figure 9.7.2\(B\)](#) for a typical example of a prohibition sign.



Figure 9.7.2(A) — Warning sign for non-drinking water outlet

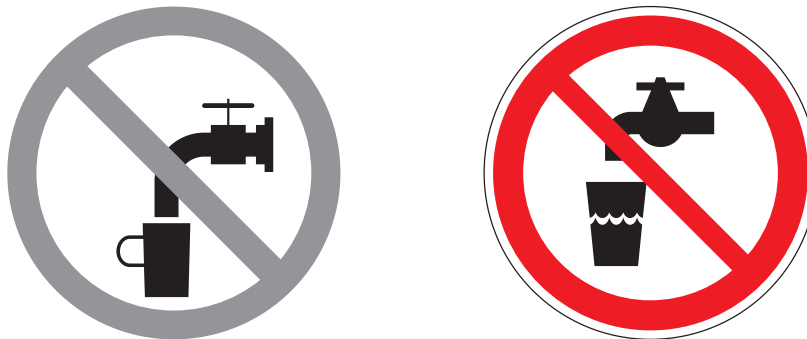

Figure 9.7.2(B) — Typical examples of prohibition signs

## 9.8 Testing and commissioning a non-drinking water service

### 9.8.1 Flushing and testing

Prior to use, the non-drinking water service shall be —

- (a) flushed in accordance with [Clause 17.2](#); and
- (b) hydrostatically tested in accordance with [Clause 17.3](#).

### 9.8.2 Commissioning a non-drinking water service

A non-drinking water service shall be commissioned as follows:

- (a) Turn on the drinking water supply at the meter or isolation valve.
- (b) Turn off the non-drinking water supply at the meter or isolation valve.

- (c) Turn on all tapware (both heated and cold) and appliances one by one. Water shall flow from all drinking water tapware and appliances.
- (d) Flush all toilets. The toilets shall not refill (provided they are connected to the non-drinking water service).
- (e) Turn on all external hose tap outlets. Water shall flow continuously from the drinking water hose tap outlets with the non-drinking water running dry.
- (f) Turn the non-drinking water meter tap back on slowly so that all air will be purged from the pipeline while it is being recharged.

NOTE The commissioning process may be repeated for the drinking water supply. This process is as follows:

- (a) Turn off the drinking water supply at the meter or isolation valve.
- (b) Turn on the non-drinking water supply at the meter or isolation valve.
- (c) Turn on all heated and cold tapware, including appliances one by one.
- (d) Ensure all tap outlets and appliances have run dry.
- (e) Flush all toilets and check that the toilet cisterns have refilled after flushing.
- (f) Turn on all external hose taps.
- (g) Check that the drinking water taps have run dry.
- (h) Check that the non-drinking water taps are flowing continuously.
- (i) Turn the drinking water supply back on slowly so that all air will be purged from the pipeline while it is being recharged.
- (j) Turn the drinking water supply back on again.

## Section 10 Treated greywater services

### 10.1 Scope of section

This section specifies requirements for the installation of services for the supply of greywater, which has been treated, from a greywater treatment system to the point of re-use.

This section does not cover direct diversion greywater systems.

NOTE Refer to AS/NZS 3500.2 for information on direct diversion greywater systems.

**C10.1** *There are a number of authorities that should be consulted where treated greywater use is being considered. These authorities include the following:*

- (a) *The network utility operator(s) responsible for water supply and sewerage or both.*
- (b) *The health authority.*
- (c) *The environment protection authority.*
- (d) *Local council.*
- (e) *State or territory plumbing standards setting authority.*

*The relevant authority will —*

- (i) *determine the quality levels for the treated greywater; and*
- (ii) *the acceptable internal and external use.*

### 10.2 Materials and products

Materials and products used in the installation of greywater water services shall be as specified in [Section 2](#).

### 10.3 Cross-connection control

Greywater installations shall be designed, installed and maintained to prevent a cross-connection with drinking water supply. Where a property is served by a greywater supply, the following shall apply:

- (a) A backflow prevention device for the degree of hazard shall be fitted at the meter (or at the boundary when a meter is not installed) on the drinking water supply.

NOTE 1 In Australia, refer to the NCC for the degrees of hazard.

NOTE 2 In New Zealand, refer to Acceptable Solution G12/AS1 for information regarding cross connection hazard ratings.

- (b) Each external tap on the drinking water service shall be fitted with a low hazard backflow prevention device, such as a hose connection vacuum breaker (see [Section 4](#)).
- (c) Cross-connection protection from any greywater service shall meet the requirements of [Section 4](#).

### 10.4 Installation

Installation of a water supply system from a greywater treatment unit shall be as specified in [Section 9](#).

## Section 11 Water for sanitary flushing

### 11.1 Scope of section

This section specifies requirements for water services used for sanitary flushing purposes.

### 11.2 General

Sanitary fixtures that are cleansed by the action of a flush shall have water supplied by one of the following:

- (a) A cistern.
- (b) A flush valve supplied by a separate break tank in accordance with [Clause 11.6](#).
- (c) A flush valve connected to the drinking water supply service in accordance with [Clause 11.9](#).
- (d) A flush valve supplied through an anti-back-siphonage device.

NOTE Flushing devices may be used on the following fixtures:

- (a) Water closet pan.
- (b) Urinal.
- (c) Slop hopper pan.
- (d) Combination pan room sink and flush bowl.
- (e) Bedpan washer.
- (f) Floor waste with flushing rim.

### 11.3 Water closet

The compatibility of a water closet pan and water closet cistern or flushing device shall be determined prior to installation.

### 11.4 Urinals

Flush valves that connect to urinals shall be installed so that the operating mechanism is not more than 2 m above the floor level. Flush valves shall be accessible and installed above the level of the sparge pipe by not less than —

- (a) 300 mm for wall-hung urinals; and
- (b) 450 mm for continuous wall urinals.

### 11.5 Installation of cisterns

#### 11.5.1 General

Cisterns shall be installed so they are capable of being maintained and serviced.

#### 11.5.2 Urinal type cisterns

Cisterns that connect to urinals shall be installed at a height of not less than 300 mm for wall-hung type urinals and 450 mm for continuous wall urinals, above the level of the sparge pipe or spreader of the urinal stall, measured to the underside of the cistern.

### 11.5.3 Manually operated cisterns

Manually operated cisterns shall be installed so that the cistern's operating control is positioned at a height of not more than 2 m, measured from the floor level.

### 11.5.4 Water closet pan and slop hopper pan type cisterns

Cisterns shall be compatible with the water closet pan or slop hopper pan to which they connect.

NOTE Refer to AS 1172.2 for information on cistern requirements.

## 11.6 Flush valves supplied from break tanks

### 11.6.1 General

Break tanks shall be installed in accordance with the requirements of [Section 8](#). Break tanks shall not be used to supply water for drinking purposes.

### 11.6.2 Capacity

The water storage to be provided for flush valves serving water closets shall be not less than 45 L for each flush valve served, and 30 L for each flush valve serving urinals.

### 11.6.3 Operating head

The operating water pressure supplied to any flush valve shall not exceed 300 kPa.

### 11.6.4 Pipe size guide

NOTE Guidance on the size of service pipes from break tanks to flush valves is given in [Table 11.6.4](#).

**Table 11.6.4 — Service pipe sizes — Break tanks to flush valves**

Available head of water at highest flush valve m	Maximum number of flush valves served downstream on the same floor and at lower levels	Nominal size of service pipes DN
> 3 ≤ 6	1 to 2	40
	3 to 15	50
	16 to 50	65
	51 to 150	80
> 6 ≤ 9	1 to 3	40
	4 to 30	50
	31 to 150	65
	151 to 200	80
> 9 ≤ 12	1 to 4	40
	5 to 50	50
	51 to 200	65
> 12	1 to 6	40
	7 to 100	50
	101 to 250	65

### 11.6.5 Urinal flush valves

Each urinal flush valve shall supply water to not more than three separate urinal stalls, or a continuous urinal wall not more than 1.8 m in length. Only urinal stalls that are located adjacent to each other shall be supplied from a common flush valve.

### 11.7 Flush pipes and water flow distribution

Cisterns and flush valves shall supply water to a fixture through a flush pipe or, in the case of a urinal, through a flush pipe or a distribution system in accordance with [Table 11.7](#).

**Table 11.7 — Flushing water flow distribution**

Volume of water discharged by the cistern or flushing valve <b>L</b>	Maximum length of urinal wall served per cistern or flushing valve <b>mm</b>	Minimum number of spreaders for the urinal	Nominal size of flush pipe <b>DN</b>	Nominal size of spreader <b>DN</b>
2.5	450 <sup>a</sup>	1	20	—
2.5	600	1	25	20
5.0	1 200	3	32	25
7.5	1 800	4	40	25
10.0	2 400	5	50	25

<sup>a</sup> Wall-hung unit.

### 11.8 Pressure ratio valves

#### 11.8.1 General

Pressure ratio valves shall be —

- (a) installed in the service piping in duplicate and in parallel, and each valve shall be separately sized to cater for the total simultaneous demand;

NOTE For a typical valve installation involving a pressure ratio valve, see [Figure 11.8.1](#).

- (b) controlled by means of stop valves, installed at both the inlet and outlet of each ratio valve, which under normal operating conditions shall be fully opened;
- (c) installed in an accessible position where they will not be subject to interference;
- (d) readily removable by means of flanged or union type joints; and
- (e) not less than the nominal size of the section of pipeline in which they are installed.

#### 11.8.2 Requirement for pressure gauges

Pressure gauges that are calibrated to read higher than the available working head in the particular installation shall be installed on the inlet and outlet of each ratio valve assembly.

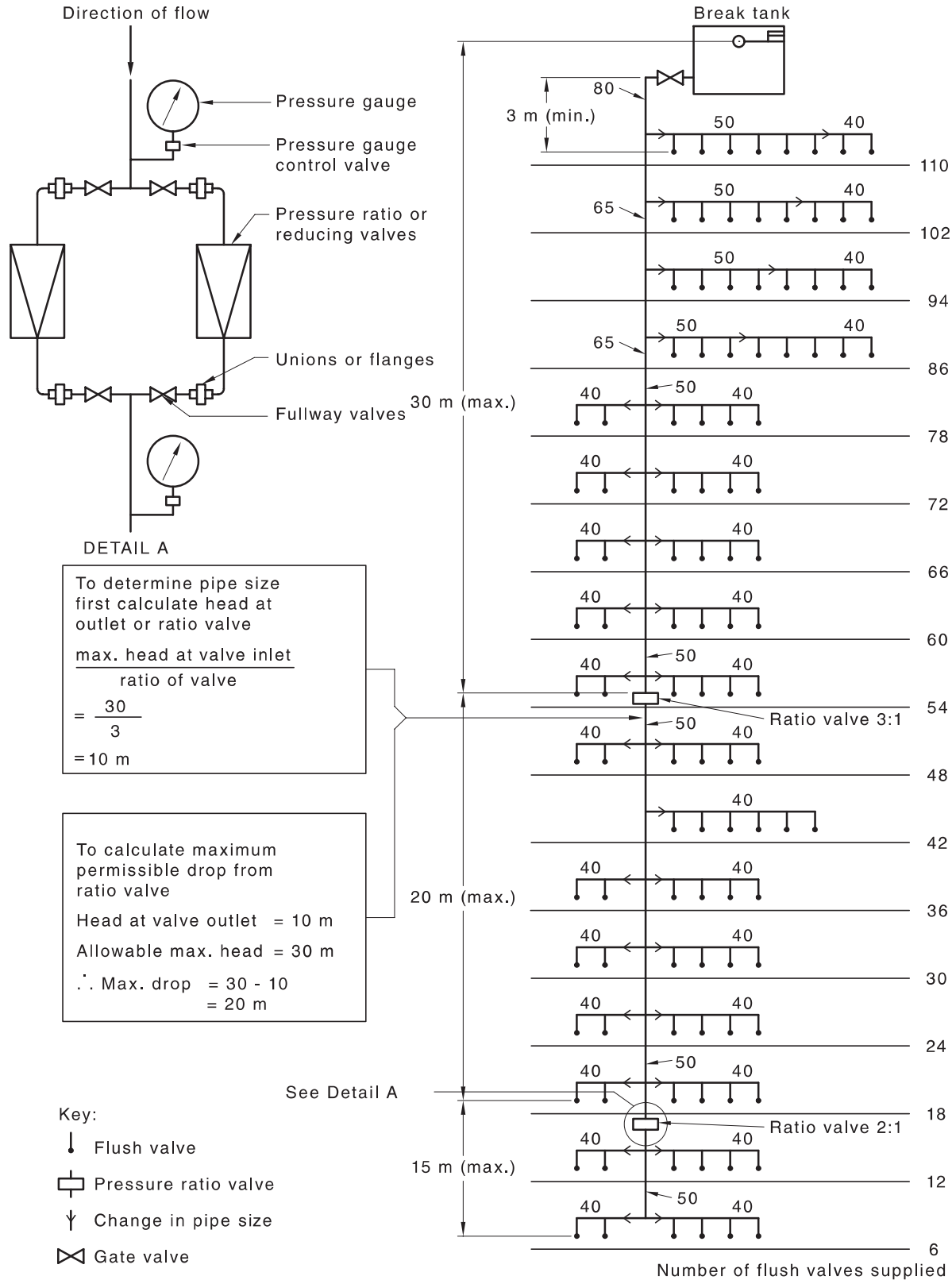

## **11.9 Flush valves connected to the drinking water service**

### **11.9.1 General**

Flush valves for connection either to the water service or to a storage tank supplying other fixtures shall incorporate within the valves a back-siphonage prevention device and be installed in accordance with [Clauses 11.9.2](#) to [11.9.7](#).

### **11.9.2 Compatibility**

The flush valve shall be compatible with the fixture to which it is connected.

### **11.9.3 Pipe size**

The minimum pipe size serving the flush valve shall be DN 25. The sizes of all pipework to the valve shall be hydraulically calculated.

### **11.9.4 Protection**

The back-siphonage prevention device incorporated in the flush valve shall be protected against interference and possible blockage.

### **11.9.5 Location**

The flush valve shall be installed such as to place the outlet at a minimum of 450 mm above the rim of the pan.

### **11.9.6 Pressure and velocity limitations**

Flush valves shall only be installed where the pressure and flow are sufficiently high to effectively operate the valve and not interfere with the operation of any other appliances dependent on the pressure from the water supply.

### **11.9.7 Branch service pipe**

For maintenance purposes, the branch service pipe to each flush valve or group of flush valves shall be provided with a stop valve.

## Section 12 Pumps

### 12.1 Scope of section

This section specifies requirements for the installation of pumps used in water services for buildings.

### 12.2 General

Where the available water supply cannot meet the minimum pressure and flow rates of [Section 3](#), storage tanks and/or pumps shall be installed to achieve the pressure and flow rate demands in accordance with [Section 3](#).

NOTE Pumping directly from the water main is not permitted by some network utility operators.

### 12.3 Control of pumps

Pumps shall be controlled to limit the number of starts per hour to within the capacity of the pump.

### 12.4 Installation of pumps

Pumps shall have —

- (a) vibration eliminators at the base of the pump, on the suction side and the delivery side of the pump, to minimize the transmission of noise into the building structure and along the piping system and to prevent undue stress being placed on the pump;
- (b) isolation valves on the delivery side and suction side of the pump;
- (c) a non-return valve on the delivery side of the pump before the isolation valve;
- (d) pressure gauges on the inlet and outlet of the pump; and
- (e) unions or flanges to enable the pump's removal.

NOTE 1 A restrictive device may be installed between the flanges at the outlet of the pump or a suction storage tank may be provided.

NOTE 2 Where it is intended to install a stand-by pump arrangement, the pumps should be electrically coupled in such a manner that each pump can operate individually but can be changed over for stand-by or alternative duty.

### 12.5 Booster pumps

Booster pumps shall be wired electrically so that the operation of the pump is controlled by float switches or other devices located at the storage tank or pressure vessel. Booster pumps and their appurtenances shall be installed in such a manner as to be readily accessible.

## Section 13 Water requirements for haemodialysis machines

### 13.1 Scope of section

This section specifies requirements for water services installed to supply haemodialysis machines.

NOTE 1 Where it is intended to carry out any work in connection with water supply, water analysis samples should be obtained prior to installation in relation to the degree of hardness or amount of chlorine residual.

NOTE 2 The network utility operator should be notified prior to connection of the machine to enable records to be kept and metallic notification discs to be fitted on all water main valves in the vicinity of the machine, to prevent or minimize disruption of the supply.

### 13.2 Connection to the water service

A stop valve, strainer and backflow prevention device in accordance with [Section 4](#) shall be installed at the connection of the water supply to the haemodialysis machine.

### 13.3 Maintenance of flow rate

The water service to the haemodialysis machine shall be capable of maintaining the flow rate required by the haemodialysis machine during periods of peak demand.

### 13.4 Water meters

Where a water meter is installed, it shall be blue in colour denoting that a haemodialysis machine is connected to the water supply.

## Section 14 Property water meters

### 14.1 Scope of section

This section specifies general requirements for the location, installation, electrical safety precautions and protection of property water meters.

NOTE 1 Installation of a network utility operator's water meters should be undertaken in accordance with the network utility operator's requirements.

NOTE 2 For electrical safety precaution and earthing, see [Commentary C5.1](#).

### 14.2 Location of water meters

Water meters shall be —

- (a) located so as to be accessible for reading, maintenance and removal;
- (b) located in areas not susceptible to ponding;
- (c) orientated horizontally, unless designed to operate otherwise; and
- (d) positioned immediately downstream of the meter-isolating valve.

NOTE 1 See [Figure 14.2](#) for typical installation of a property service and water service.

NOTE 2 In many parts of Australia and New Zealand, the maintenance of the property service is the responsibility of the network utility operator. Pipes used in a property service or meter assembly are installed to the network utility operator's specification (see [Figure 14.2](#)).

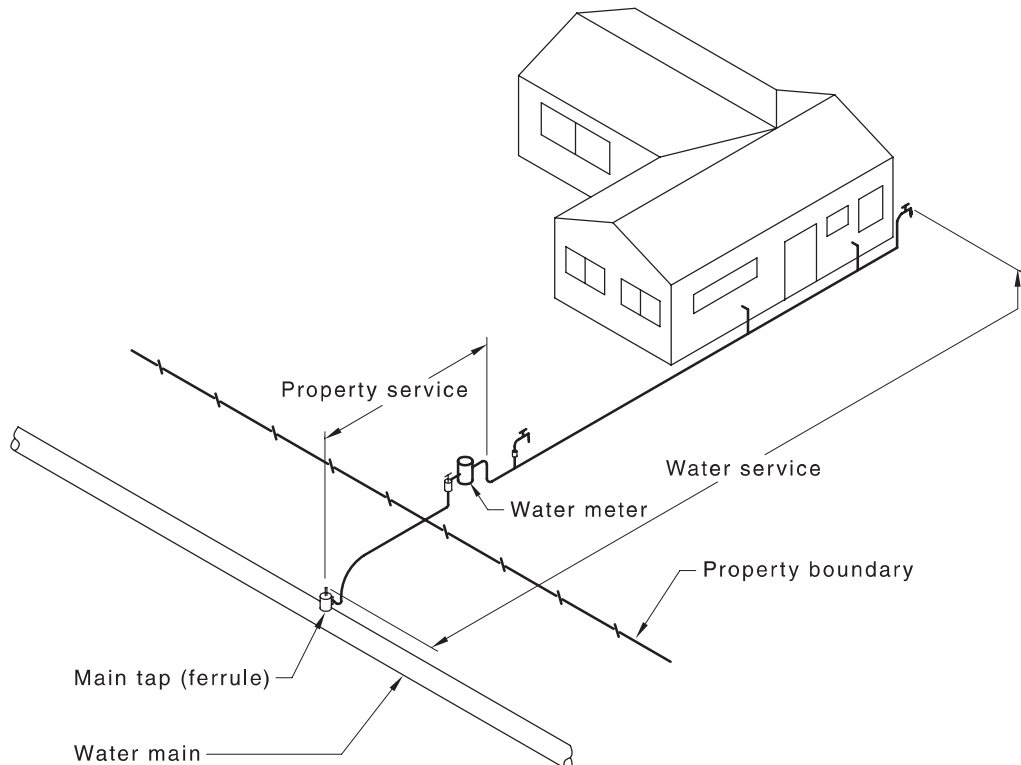

**Figure 14.2 — Typical installation of a property service and water service where connected to the network utility operator's water main**

### 14.3 Installation inside buildings

Where a water meter is installed inside a building and where water damage may result from the removal of the meter, an additional isolating valve shall be fitted adjacent to the meter outlet.

### 14.4 Installation below ground

Water meters installed below ground shall be located in a meter box that has —

- (a) a cover that can be removed; and
- (b) a base that enables drainage.

NOTE The cover should be adequately sized to allow for maintenance and removal of the meter.

### 14.5 Protection from mechanical damage

Where likely to be subject to mechanical damage, water meters shall be protected.

### 14.6 Frost protection

Water meters and meter assemblies located in frost-prone areas shall be protected against damage caused by freezing of water.

NOTE Possible solutions include in-ground installation, or installation in an insulated enclosure.

## Section 15 Installation of water supply system from rainwater tanks

### 15.1 Scope of section

This section specifies minimum requirements for the installation of a water supply system from a rainwater tank, where the tank is collecting water from roof catchments and is installed in an area where water from a network utility operator is provided to the property.

**C15.1** *There are a number of authorities that should be consulted, particularly when the services are to be interconnected or where the water is to serve common fittings within the property. These authorities include the following:*

- (a) *The water supplier (network utility operator), which may determine the conditions to be met to allow connection of the rainwater system to their water supply (i.e. the minimum containment protection).*
- (b) *The health authority, which determines water quality standards, and may set guidelines on the use of water from rainwater tanks. The health authority may also recommend against the use of rainwater tanks in certain areas due to pollution. Guidelines on the use of rainwater tanks have been developed by enHealth (Guidance on use of rainwater tanks).*

### 15.2 Pipes, valves and fittings

All pipes, valves and fittings within a water supply system from a rainwater tank shall be as specified in [Section 2](#).

### 15.3 Installation

#### 15.3.1 General

The water supply system from a rainwater tank shall be as specified in [Section 5](#).

Backflow prevention shall be as specified in [Section 4](#) or [Clause 15.3.3](#).

NOTE The network utility operator may require containment protection at the property boundary.

#### 15.3.2 Additional marking and signage of pipework and outlets

##### 15.3.2.1 Pipework

Pipework from a rainwater tank shall be clearly marked with the word “RAINWATER” at intervals not exceeding 500 mm where concealed in walls, or 1 m where exposed or buried.

Marking shall be —

- (a) around the circumference at the above intervals; or
- (b) longitudinally at the above intervals along the pipe.

NOTE 1 Labels or stickers marked to AS 1345 may be fixed to the pipe.

NOTE 2 Refer to AS 1345 for information on the identification of the contents of pipes, conduits and ducts.

### 15.3.2.2 Water outlets

Water outlets shall be identified as “RAINWATER” or, in the case of a rainwater tap, identified by a green coloured indicator with the letters “RW”.

NOTE A typical sign is shown in [Figure 15.3.2.2](#).

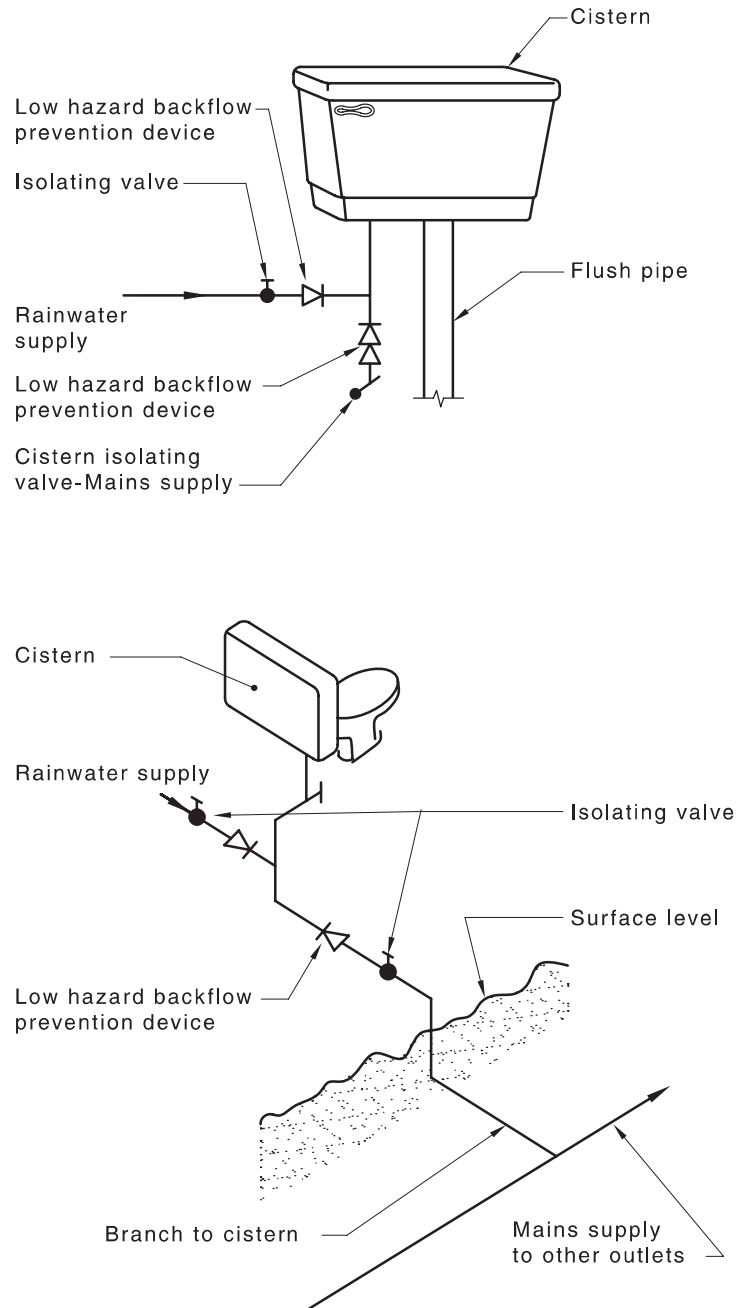

Figure 15.3.2.2 — Typical sign for rainwater outlets

### 15.3.3 Connection between service pipes

Where a water supply system from a rainwater tank is connected with the water service from a network utility operator’s water supply, the following applies:

- (a) Backflow prevention shall be provided to protect the network utility operator’s water supply.
- (b) Where the rainwater is being used as a supply to a flushing device, either a low hazard backflow prevention device as shown in [Figure 15.3.3](#) or a dual inlet cistern shall be provided.
- (c) A device shall be provided on the pipeline from the rainwater tank to prevent water from the network utility operator’s water supply flowing into the rainwater tank.



**Figure 15.3.3 — Connection of service pipes at cisterns**

## 15.4 Testing and commissioning a rainwater system

### 15.4.1 Flushing and testing

Prior to use, the rainwater service shall be —

- (a) flushed in accordance with [Clause 17.2](#); and
- (b) hydrostatically tested in accordance with [Clause 17.3](#).

### 15.4.2 Commissioning a rainwater system

A rainwater system shall be commissioned as follows:

- (a) Turn on the drinking water supply at the meter or isolation valve.
- (b) Ensure the rainwater water supply is off at the meter or isolation valve.
- (c) Turn on all tapware (*both heated and cold*) and appliances one by one. Ensure water is flowing from all drinking water tapware and appliances.
- (d) Flush all toilets. The toilets shall not refill (provided they are connected to the rainwater system).
- (e) Turn on all external hose tap outlets. Water shall flow continuously from the drinking water hose tap outlets with the rainwater service running dry.
- (f) Turn the rainwater system tap back on slowly so that all air will be purged from the pipeline while it is being recharged.

NOTE The commissioning process may be repeated for the drinking water supply as follows:

- (a) Turn off the drinking water supply at the meter or isolation valve.
- (b) Turn on the rainwater water supply at the meter of isolation valve.
- (c) Turn on all heated and cold tapware, including appliances one by one.
- (d) Check that tap outlets and appliances have run dry.
- (e) Flush all toilets. Check that the toilet cisterns have refilled after flushing.
- (f) Turn on all external hose taps.
- (g) Check that the drinking water taps have run dry.
- (h) Check that the rainwater water taps are flowing continuously.
- (i) Turn the drinking water supply back on slowly so that all air will be purged from the pipeline while it is being recharged.

## Section 16 Multi-unit developments

### 16.1 Scope of section

This section specifies minimum requirements for main lines of water services located within common property of a multi-unit development of 20 or more residential buildings up to three storeys in height.

### 16.2 Methods of design and installation

Design and installation of the main lines of the water service shall conform to:

- (a) This document, including [Clauses 16.3](#) to [16.5](#).
- (b) In Australia, WSA 03, *Water Supply Code of Australia*.

### 16.3 Division of development

The development shall be divided into zones. The number of allotments within a zone, affected by any shut-off at the main lines of the water service, shall not exceed 40. The dividing or isolation valves that are fitted to the main line itself shall be at intervals not exceeding 300 m.

### 16.4 Ring mains and flushing points

To maintain circulation of water, the main lines of the water service shall form a ring main or be provided, at surface level, with flushing points at any dead end of the main line of the water service.

### 16.5 Fire services

External fire hydrants shall be located in accordance with [Section 6](#).

## Section 17 Testing and commissioning

### 17.1 Scope of section

This section specifies requirements for testing and commissioning a water service.

### 17.2 Flushing

At the completion of the water service installation and prior to hydrostatic testing, the system shall be thoroughly flushed to remove any foreign matter. The flushing shall be undertaken in accordance with [Clause H.3](#) and continue until the flushed water runs completely clear. The system shall then be pressure-tested in accordance with [Clause 17.3.1](#).

The water service used to supply drinking water shall be protected against contamination in accordance with [Appendices G](#) and [H](#).

NOTE See [Section 9](#) for testing and commissioning non-drinking water services.

### 17.3 Testing

#### 17.3.1 Hydrostatic test

Water services shall not show any leakage when subjected to a hydrostatic pressure of 1 500 kPa for a period of not less than 30 min.

The test shall be performed on installed piping prior to burial or concealment. In the case of pipe systems with elastomeric seals, the piping shall be backfilled leaving the joints exposed until completion of the test.

NOTE 1 When a pressure test is carried out, it may be necessary to disconnect and cap the water service to isolate it from the water main, fixtures and appliances, which may be damaged by the test pressure applied.

NOTE 2 Fire services are subject to individual testing by some network utility operators at a higher pressure and for varied periods of time.

#### 17.3.2 Storage tanks (except rainwater tanks)

Storage tanks (except rainwater tanks) shall be filled until they overflow for a period of not less than 1 min. The overflow shall discharge in accordance with [Clause 8.4.4.2](#).

Conformance to the air gap criteria shall be verified, see [Clause 4.6.3.2\(a\)](#).

Air gaps shall conform to [Clause 4.6.3.2\(a\)](#).

### 17.4 Cleaning and disinfection of drinking water storage tanks

The disinfection of drinking water storage tanks shall be carried out in accordance with [Appendix G](#).

### 17.5 Disinfection of water services

The disinfection of water services shall be carried out in accordance with [Appendix H](#).

### 17.6 Commissioning

At the completion and testing of the water service, the operation of all valves, cisterns, taps, pressure-relief valves and other components shall be checked to confirm their correct performance.

## Appendix A (normative)

### Equivalent pipe sizes

This appendix provides tables for selecting the appropriate pipe nominal diameter (DN), based on internal diameter for different pipe materials and types, standard dimension ratios (SDRs) or pressure classes, as marked on the pipe. The equivalent pipe DN for different materials shall be determined using [Tables A.1, A.2, A.3, A.4](#) and [A.5](#).

Multilayer pipes and ABS pipes are not covered by this appendix.

For multilayer pipes, and ABS pipes, the equivalent pipe DN shall be selected on the basis of the internal diameters specified by the pipe supplier.

NOTE 1 Standard dimension ratio (SDR) — Plastic pipes may be categorized by their SDR value. It is the ratio of the nominal outside diameter of the pipe to its nominal wall thickness,  $SDR = DN/T$ . SDR values are printed onto pipes and can be obtained from the pipe manufacturer.

NOTE 2 Values in the tables were calculated from the values for maximum outside diameter and minimum wall thickness as specified in the respective pipe product Standards as follows:

- (a) AS 1432 — Copper (Australia).
- (b) NZS 3501 — Copper (New Zealand).
- (c) AS/NZS 2492 — PE-X.
- (d) AS 5082.1 — PB (metric series).
- (e) AS/NZS 2642.2 — PB (imperial series).
- (f) AS/NZS 4130 — PE.
- (g) AS/NZS 1477 — PVC-U.
- (h) AS/NZS 4765 — PVC-M.
- (i) AS/NZS 4441 — PVC-O.
- (j) ISO 15874-2 — PP-R.
- (k) AS 5200.053 — Stainless steel.

**Table A.1 — Internal diameters for copper pipes and tubes**

DN	Copper in accordance with AS 1432 (Australia)			Copper in accordance with NZS 3501 (New Zealand)
	Type A mm	Type B mm	Type C mm	
10	7.5	7.7	8.1	9.5
15	10.7	10.9	11.3	12.7
18	13.4	13.8	14.1	—
20	16.2	17.0	17.2	19.0
25	22.1	23.0	23.6	25.4
32	28.5	29.3	—	31.8
40	34.8	35.7	—	38.1
50	47.5	48.4	—	50.8
65	60.2	61.1	—	63.5
80	72.1	72.9	—	76.2
90	85.8	85.6	—	88.9
100	97.5	98.3	—	101.6
125	122.9	123.7	—	127.0
150	147.1	148.3	—	152.4
200	197.9	199.1	—	188.5

**Table A.2 — Internal diameters for stainless steel pipes and tubes**

DN	Stainless steel pipes in accordance with ASME B36.19M		Stainless steel tubes in accordance with EN 10312
	Schedule 5S mm	Schedule 10S mm	
15	18.0	17.1	13.0
18	—	—	16.0
20	23.4	22.5	19.6
25	30.1	27.9	25.6
32	38.9	36.6	32.0
40	45.0	42.7	39.0
50	57.0	54.8	51.0
65	68.8	66.9	72.1
80	84.7	82.8	84.9
100	110.1	108.2	104.0
125	135.8	134.5	—
150	162.8	161.5	—
200	213.6	211.6	—

**Table A.3 — Internal diameters for polyolefin pipes**

DN	PE, PE-X, PP-R, PB (metric)		
	SDR 11 mm	SDR 9 mm	SDR 7.4 mm
16	13.1	12.7	11.9
20	16.5	15.7	14.7
25	20.7	19.7	18.3
32	26.5	25.1	23.5
40	33.0	31.4	29.4
50	41.2	39.3	36.7
63	52.0	49.4	46.4
75	62.1	58.6	55.1
90	74.5	70.7	66.3
110	91.0	86.4	80.8
125	103.4	98.2	92.0
140	115.9	109.9	102.9
160	132.3	125.7	117.1
180	148.9	141.5	132.5
200	165.4	157.0	147.2

**Table A.4 — Internal diameters for PVC-U pipes**

DN	PVC-U		
	PN12 mm	PN15 mm	PN18 mm
10	—	—	14.5
15	—	18.7	18.3
20	24.1	23.5	22.9
25	30.3	29.5	28.7
32	38.0	37.0	36.0
40	43.4	42.2	41.2
50	54.3	52.9	51.3

**Table A.5 — Internal diameters for imperial PB pipes**

PB (imperial)	
Nominal outside diameter mm	Imperial diameter for Class 16 pipe mm
15	9.6
18	12.8
22	18.1
28	22.8

## Appendix B (informative)

### Demonstrating products and materials are fit for purpose

#### B.1 General

The products and materials used should be selected to ensure that they are fit for their intended purpose (see [Clause 2.2](#)) taking into account —

- (a) the type of usage likely to occur;
- (b) the nature and temperature of the water to be conveyed and the risk of corrosion, degradation and leaching;
- (c) the nature of the environment, the ground and the possibility of chemical attack therefrom;
- (d) the physical and chemical characteristics of the materials and products;
- (e) compatibility of materials and products;
- (f) the pressure rating of pipes and fittings; and
- (g) accessibility for inspection and maintenance.

Information on some of the items listed above may be obtainable from the manufacturer or supplier of the product or material.

#### B.2 Australia

The WaterMark Certification Scheme is a mandatory certification scheme for plumbing and drainage products to ensure they are fit for purpose and appropriately authorized for use in plumbing and drainage installations.

Volume Three of the National Construction Code, the Plumbing Code of Australia (PCA), requires that any product intended for use in contact with drinking water must conform to the relevant requirements of AS/NZS 4020. The PCA also requires certain plumbing and drainage products to be certified and authorized for use in a plumbing or drainage system. These products are certified through the WaterMark Certification Scheme and listed on the WaterMark Product Database.

A comprehensive listing of products predetermined as requiring WaterMark is contained on the WaterMark Schedule of Products which mandates the specification to which the products must be certified. Products listed on the WaterMark Schedule of Products are deemed by the PCA to be fit for its intended purpose if it has a WaterMark Licence.

The WaterMark Schedule of Excluded Products details products that have been predetermined as not requiring WaterMark certification, however, the PCA requires evidence of suitability.

The Australian Building Codes Board update these documents on an irregular basis. The updates generally include the addition of new products that have undergone a risk assessment and that are determined to require WaterMark certification, as well as updates to specifications that are approved for use, revised or suspended.

Products not included on the WaterMark Schedule of Products or the WaterMark Schedule of Excluded Products, which are proposed to be used in a plumbing or drainage system, require an assessment to

be undertaken by a WaterMark Conformity Assessment Body to determine if WaterMark certification is necessary.

The WaterMark Product Database lists products that have been certified and marked in accordance with the requirements of the WaterMark Certification Scheme. These products are recognized by authorities as being authorized for use in a plumbing or drainage system.

NOTE The Plumbing Code of Australia, WaterMark Schedule of Products, Schedule of Excluded Products, and Database can be accessed at <https://www.ABCB.gov.au>.

### B.3 New Zealand

Plumbing and drainage systems must be constructed using materials and products fit for their intended purpose to achieve the relevant requirements of the New Zealand Building Code (NZBC).

For the purposes of conformance to this document, a material or product for plumbing or drainage systems may be deemed fit for purpose if it —

- (a) has been manufactured in accordance with a Standard cited within a current NZBC Acceptable Solution or Verification Method;
- (b) has current certification in accordance with the New Zealand CodeMark Certification Scheme;
- (c) has been certified and marked in accordance with the requirements of the Australian WaterMark Certification Scheme and is listed on the [WaterMark Product Database](#); or
- (d) has been accepted by the approving authority as meeting the performance criteria of the NZBC.

Any product that is intended for use in contact with drinking water must conform to the relevant requirements of AS/NZS 4020. A test report provided by a certification body or an accredited testing laboratory must be provided to demonstrate compliance.

All products must be suitable for use in the location they are used.

An approving authority may prohibit the use of particular materials where local conditions are likely to cause the materials to corrode or otherwise deteriorate.

## Appendix C (informative)

### Sizing method for supply piping for dwellings

#### C.1 General

The sizing method given in this appendix may be used as an alternative to a full hydraulic calculation for the rapid sizing of piping, using the probable simultaneous demand (PSD) values given in [Table 3.2.3](#).

The probable simultaneous flow rates given in [Table C.1](#) have been calculated from the following equations:

$$Q = 3.637 \times 10^{-5} H^{0.555} D^{2.667} \quad \text{C.1}$$

where

$Q$  = flow rate, in litres per second (see Note)

$D$  = pipe internal diameter, in millimetres

$H$  = head loss gradient, in metres per 100 m

$$= \frac{h \times 100}{L \times 1.5}$$

where

$h$  = head loss, in metres head

$L$  = index length, in metres

1.5 is a factor to allow for the additional head loss through fittings

Conversion factors: 1 kPa = 0.102 m head, 1 m head = 9.8 kPa.

NOTE Where velocity would have exceeded the design maximum of 3.0 m/s (see [Clause 3.4](#)), the flow rates in [Table C.1](#) have been reduced to limit the velocity to 3.0 m/s.

Table C.1 — Pipe sizing for maximum velocity of 3 m/s

PRESSURE DROP = 4 m HEAD																						
INDEX LENGTH, m																						
DN	5	10	15	20	25	30	35	40	45	50	60	70	80	90	100	110	120	130	140	150	160	
Probable simultaneous flow rate, L/s																						
10	0.08	0.05	0.04	0.04	0.03	0.03	0.03	0.02	0.02	0.02	0.02	0.02	0.02	0.02	0.01	0.01	0.01	0.01	0.01	0.01	0.01	0.01
15	0.19	0.13	0.10	0.09	0.08	0.07	0.07	0.06	0.06	0.05	0.05	0.04	0.04	0.04	0.04	0.03	0.03	0.03	0.03	0.03	0.03	0.03
18	0.36	0.25	0.20	0.17	0.15	0.14	0.12	0.12	0.11	0.10	0.09	0.08	0.08	0.07	0.07	0.07	0.06	0.06	0.06	0.06	0.06	0.05
20	0.63	0.43	0.34	0.29	0.26	0.23	0.22	0.20	0.19	0.18	0.16	0.15	0.14	0.13	0.12	0.11	0.11	0.10	0.10	0.10	0.10	0.09
25	1.24	0.96	0.77	0.65	0.58	0.52	0.48	0.44	0.42	0.39	0.35	0.33	0.30	0.28	0.27	0.25	0.24	0.23	0.22	0.21	0.21	0.21
32	2.02	1.84	1.47	1.25	1.11	1.00	0.92	0.85	0.80	0.75	0.68	0.62	0.58	0.54	0.51	0.49	0.46	0.44	0.43	0.41	0.39	0.39
40	3.00	3.00	2.47	2.11	1.87	1.69	1.55	1.44	1.35	1.27	1.15	1.05	0.98	0.92	0.86	0.82	0.78	0.75	0.72	0.69	0.67	0.67
50	5.51	5.51	5.51	4.77	4.21	3.80	3.49	3.24	3.03	2.86	2.59	2.37	2.21	2.07	1.95	1.85	1.76	1.68	1.62	1.56	1.50	1.50
65	8.78	8.78	8.78	8.78	7.85	7.05	6.50	6.03	5.65	5.33	4.82	4.42	4.11	3.85	3.63	3.44	3.28	3.14	3.01	2.90	2.80	2.80
80	12.54	12.54	12.54	12.54	12.54	11.34	10.44	9.69	9.08	8.57	7.74	7.11	6.60	6.18	5.83	5.53	5.27	5.04	4.84	4.66	4.49	4.49
100	22.78	22.78	22.78	22.78	22.78	22.78	22.78	21.50	20.16	19.00	17.17	15.77	14.64	13.71	12.94	12.27	11.69	11.18	10.73	10.33	9.97	9.97
PRESSURE DROP = 6 m HEAD																						
INDEX LENGTH, m																						
DN	5	10	15	20	25	30	35	40	45	50	60	70	80	90	100	110	120	130	140	150	160	
Probable simultaneous flow rate, L/s																						
10	0.1	0.07	0.05	0.04	0.04	0.04	0.03	0.03	0.03	0.03	0.02	0.02	0.02	0.02	0.02	0.02	0.02	0.02	0.02	0.01	0.01	0.01
15	0.24	0.16	0.13	0.11	0.1	0.09	0.08	0.08	0.07	0.07	0.06	0.06	0.06	0.05	0.05	0.04	0.04	0.04	0.04	0.04	0.04	0.04
18	0.45	0.31	0.25	0.21	0.19	0.17	0.16	0.14	0.14	0.13	0.12	0.11	0.1	0.09	0.09	0.08	0.08	0.07	0.07	0.07	0.07	0.07
20	0.68	0.54	0.43	0.37	0.32	0.29	0.27	0.25	0.23	0.22	0.2	0.18	0.17	0.16	0.15	0.14	0.14	0.13	0.12	0.12	0.12	0.12
25	1.24	1.2	0.96	0.82	0.72	0.65	0.6	0.56	0.52	0.49	0.44	0.41	0.38	0.35	0.33	0.32	0.3	0.29	0.28	0.27	0.26	0.26
32	2.02	2.02	1.83	1.57	1.39	1.25	1.15	1.07	1	0.94	0.85	0.78	0.73	0.68	0.64	0.61	0.58	0.55	0.53	0.51	0.49	0.49
40	3	3	3	2.65	2.34	2.11	1.94	1.8	1.69	1.59	1.44	1.32	1.23	1.15	1.08	1.03	0.98	0.94	0.9	0.86	0.83	0.83
50	5.51	5.51	5.51	5.51	5.28	4.74	4.37	4.06	3.8	3.58	3.24	2.97	2.76	2.59	2.44	2.31	2.21	2.11	2.02	1.95	1.88	1.88
65	8.78	8.78	8.78	8.78	8.78	8.78	8.13	7.55	7.08	6.68	6.03	5.54	5.14	4.82	4.54	4.31	4.11	3.93	3.77	3.63	3.5	3.5
80	12.54	12.54	12.54	12.54	12.54	12.54	12.54	12.13	11.38	10.72	9.69	8.9	8.26	7.74	7.3	6.93	6.6	6.31	6.06	5.83	5.63	5.63
100	22.78	22.78	22.78	22.78	22.78	22.78	22.78	22.78	22.78	22.78	21.5	19.74	18.34	17.17	16.2	15.36	14.64	14	13.44	12.94	12.48	12.48

Table C.1 (continued)

PRESSURE DROP = 8 m HEAD																						
INDEX LENGTH, m																						
DN	5	10	15	20	25	30	35	40	45	50	60	70	80	90	100	110	120	130	140	150	160	
Probable simultaneous flow rate, L/s																						
10	0.11	0.08	0.06	0.05	0.05	0.04	0.04	0.04	0.03	0.03	0.03	0.03	0.03	0.02	0.02	0.02	0.02	0.02	0.02	0.02	0.02	0.02
15	0.28	0.19	0.15	0.13	0.12	0.1	0.1	0.09	0.08	0.08	0.07	0.07	0.06	0.06	0.05	0.05	0.05	0.05	0.04	0.04	0.04	0.04
18	0.45	0.36	0.29	0.25	0.22	0.2	0.18	0.17	0.16	0.15	0.14	0.12	0.12	0.11	0.1	0.09	0.09	0.09	0.08	0.08	0.08	0.08
20	0.68	0.63	0.51	0.43	0.38	0.34	0.32	0.29	0.27	0.26	0.23	0.22	0.2	0.19	0.18	0.17	0.16	0.15	0.15	0.14	0.14	0.14
25	1.24	1.24	1.12	0.96	0.85	0.77	0.7	0.65	0.61	0.58	0.52	0.48	0.44	0.42	0.39	0.37	0.35	0.34	0.33	0.31	0.3	0.3
32	2.02	2.02	2.02	1.84	1.62	1.47	1.35	1.25	1.17	1.11	1	0.92	0.85	0.8	0.75	0.71	0.68	0.65	0.62	0.6	0.58	0.58
40	3	3	3	3	2.74	2.4	2.27	2.11	1.98	1.87	1.69	1.55	1.44	1.35	1.27	1.2	1.15	1.1	1.05	1.01	0.98	0.98
50	5.51	5.51	5.51	5.51	5.51	5.51	5.12	4.75	4.41	4.21	3.8	3.49	3.24	3.03	2.86	2.72	2.59	2.47	2.37	2.29	2.21	2.21
65	8.78	8.78	8.78	8.78	8.78	8.78	8.78	8.78	8.31	7.82	7.07	6.45	6.03	5.65	5.33	5.06	4.82	4.61	4.42	4.26	4.11	4.11
80	12.54	12.54	12.54	12.54	12.54	12.54	12.54	12.54	12.54	12.54	11.36	10.43	9.69	9.08	8.57	8.12	7.74	7.4	7.11	6.84	6.6	6.6
100	22.78	22.78	22.78	22.78	22.78	22.78	22.78	22.78	22.78	22.78	22.78	22.78	22.78	21.5	20.15	19	17.17	16.43	15.77	15.17	14.64	14.64
PRESSURE DROP = 10 m HEAD																						
INDEX LENGTH, m																						
DN	5	10	15	20	25	30	35	40	45	50	60	70	80	90	100	110	120	130	140	150	160	
Probable simultaneous flow rate, L/s																						
10	0.13	0.09	0.07	0.06	0.05	0.05	0.04	0.04	0.04	0.04	0.03	0.03	0.03	0.03	0.03	0.02	0.02	0.02	0.02	0.02	0.02	0.02
15	0.28	0.22	0.17	0.15	0.13	0.12	0.11	0.1	0.09	0.09	0.08	0.07	0.07	0.06	0.06	0.06	0.05	0.05	0.05	0.05	0.05	0.05
18	0.45	0.42	0.33	0.28	0.25	0.22	0.21	0.19	0.18	0.17	0.15	0.14	0.13	0.12	0.12	0.11	0.1	0.1	0.1	0.09	0.09	0.09
20	0.68	0.68	0.57	0.49	0.43	0.39	0.36	0.33	0.31	0.29	0.27	0.24	0.23	0.21	0.2	0.19	0.18	0.17	0.17	0.16	0.15	0.15
25	1.24	1.24	1.24	1.09	0.96	0.87	0.8	0.74	0.69	0.65	0.59	0.54	0.5	0.47	0.44	0.42	0.4	0.38	0.37	0.35	0.34	0.34
32	2.02	2.02	2.02	2.02	1.84	1.66	1.53	1.42	1.33	1.25	1.13	1.04	0.96	0.9	0.85	0.81	0.77	0.74	0.71	0.68	0.66	0.66
40	3	3	3	3	3	2.8	2.57	2.39	2.24	2.11	1.91	1.75	1.63	1.52	1.44	1.36	1.3	1.24	1.19	1.15	1.11	1.11
50	5.51	5.51	5.51	5.51	5.51	5.51	5.51	5.38	5.05	4.75	4.3	3.95	3.67	3.44	3.24	3.07	2.93	2.8	2.6	2.59	2.5	2.5
65	8.78	8.78	8.78	8.78	8.78	8.78	8.78	8.78	8.78	8.78	8.01	7.35	6.83	6.4	6.03	5.72	5.45	5.22	5.01	4.82	4.65	4.65
80	12.54	12.54	12.54	12.54	12.54	12.54	12.54	12.54	12.54	12.54	12.54	11.82	10.98	10.28	9.7	9.2	8.76	8.38	8.04	7.74	7.47	7.47
100	22.78	22.78	22.78	22.78	22.78	22.78	22.78	22.78	22.78	22.78	22.78	22.78	22.78	22.78	21.5	20.4	19.45	18.6	17.85	17.17	16.47	16.47

Table C.1 (continued)

PRESSURE DROP = 15 m HEAD																						
INDEX LENGTH, m																						
DN	5	10	15	20	25	30	35	40	45	50	60	70	80	90	100	110	120	130	140	150	160	
Probable simultaneous flow rate, L/s																						
10	0.14	0.11	0.09	0.07	0.07	0.06	0.05	0.05	0.05	0.04	0.04	0.04	0.03	0.03	0.03	0.03	0.03	0.03	0.03	0.03	0.02	0.02
15	0.28	0.27	0.22	0.19	0.16	0.15	0.14	0.13	0.12	0.11	0.1	0.09	0.09	0.08	0.08	0.07	0.07	0.07	0.06	0.06	0.06	0.06
18	0.45	0.45	0.41	0.35	0.31	0.28	0.26	0.24	0.22	0.21	0.19	0.18	0.16	0.15	0.14	0.14	0.13	0.12	0.12	0.12	0.11	0.11
20	0.68	0.68	0.68	0.61	0.54	0.49	0.45	0.42	0.39	0.37	0.33	0.3	0.28	0.27	0.25	0.24	0.23	0.22	0.21	0.2	0.19	0.19
25	1.24	1.24	1.24	1.24	1.2	1.08	0.99	0.93	0.87	0.82	0.74	0.68	0.63	0.59	0.56	0.53	0.5	0.48	0.46	0.44	0.43	0.43
32	2.02	2.02	2.02	2.02	2.02	2.02	1.91	1.77	1.65	1.57	1.42	1.3	1.21	1.13	1.07	1.01	0.96	0.92	0.89	0.85	0.82	0.82
40	3	3	3	3	3	3	3	3	2.81	2.64	2.39	2.19	2.04	1.91	1.8	1.71	1.63	1.56	1.49	1.44	1.39	1.39
50	5.51	5.51	5.51	5.51	5.51	5.51	5.51	5.51	5.51	5.51	5.38	4.91	4.59	4.3	4.06	3.85	3.67	3.51	3.37	3.24	3.13	3.13
65	8.78	8.78	8.78	8.78	8.78	8.78	8.78	8.78	8.78	8.78	8.78	8.78	8.56	8.01	7.55	7.16	6.83	6.53	6.27	6.03	5.82	5.82
80	12.54	12.54	12.54	12.54	12.54	12.54	12.54	12.54	12.54	12.54	12.54	12.54	12.54	12.54	12.14	11.51	11	10.5	10.07	9.69	9.35	9.35
100	22.78	22.78	22.78	22.78	22.78	22.78	22.78	22.78	22.78	22.78	22.78	22.78	22.78	22.78	22.78	22.78	22.78	22.78	22.35	21.52	20.75	20.75
PRESSURE DROP = 20 m HEAD																						
INDEX LENGTH, m																						
DN	5	10	15	20	25	30	35	40	45	50	60	70	80	90	100	110	120	130	140	150	160	
Probable simultaneous flow rate, L/s																						
10	0.14	0.13	0.1	0.09	0.08	0.07	0.06	0.06	0.06	0.05	0.05	0.04	0.04	0.04	0.04	0.03	0.03	0.03	0.03	0.03	0.03	0.03
15	0.28	0.28	0.25	0.22	0.19	0.17	0.16	0.15	0.14	0.13	0.12	0.11	0.1	0.09	0.09	0.08	0.08	0.08	0.07	0.07	0.07	0.07
18	0.45	0.45	0.45	0.41	0.36	0.33	0.3	0.28	0.26	0.25	0.22	0.21	0.19	0.18	0.17	0.16	0.15	0.15	0.14	0.14	0.13	0.13
20	0.68	0.68	0.68	0.68	0.63	0.57	0.53	0.49	0.46	0.43	0.39	0.36	0.33	0.31	0.29	0.28	0.27	0.25	0.24	0.23	0.23	0.23
25	1.24	1.24	1.24	1.24	1.24	1.24	1.17	1.08	1	0.96	0.87	0.8	0.74	0.69	0.65	0.62	0.59	0.56	0.54	0.52	0.5	0.5
32	2.02	2.02	2.02	2.02	2.02	2.02	2.02	2.02	1.94	1.84	1.66	1.53	1.42	1.33	1.25	1.19	1.13	1.08	1.04	1	0.96	0.96
40	3	3	3	3	3	3	3	3	3	3	2.8	2.56	2.39	2.24	2.11	2	1.91	1.83	1.75	1.69	1.63	1.63
50	5.51	5.51	5.51	5.51	5.51	5.51	5.51	5.51	5.51	5.51	5.51	5.51	5.38	5.04	4.76	4.51	4.3	4.12	3.95	3.8	3.67	3.67
65	8.78	8.78	8.78	8.78	8.78	8.78	8.78	8.78	8.78	8.78	8.78	8.78	8.78	8.78	8.78	8.4	8.01	7.66	7.35	7.08	6.83	6.83
80	12.54	12.54	12.54	12.54	12.54	12.54	12.54	12.54	12.54	12.54	12.54	12.54	12.54	12.54	12.54	12.54	12.54	12.31	11.82	11.38	10.97	10.97
100	22.78	22.78	22.78	22.78	22.78	22.78	22.78	22.78	22.78	22.78	22.78	22.78	22.78	22.78	22.78	22.78	22.78	22.78	22.78	22.78	22.78	22.78

Table C.1 (continued)

PRESSURE DROP = 25 m HEAD																						
INDEX LENGTH, m																						
DN	5	10	15	20	25	30	35	40	45	50	60	70	80	90	100	110	120	130	140	150	160	
Probable simultaneous flow rate, L/s																						
10	0.14	0.14	0.11	0.1	0.09	0.08	0.07	0.07	0.06	0.06	0.05	0.05	0.05	0.04	0.04	0.04	0.04	0.03	0.03	0.03	0.03	0.03
15	0.28	0.28	0.28	0.25	0.22	0.2	0.18	0.17	0.16	0.15	0.13	0.12	0.11	0.11	0.1	0.1	0.09	0.09	0.08	0.08	0.08	0.08
18	0.45	0.45	0.45	0.45	0.41	0.37	0.34	0.32	0.3	0.28	0.25	0.23	0.22	0.2	0.19	0.18	0.17	0.17	0.16	0.15	0.15	0.15
20	0.68	0.68	0.68	0.68	0.68	0.64	0.59	0.55	0.52	0.49	0.44	0.4	0.38	0.35	0.33	0.31	0.3	0.29	0.28	0.27	0.26	0.26
25	1.24	1.24	1.24	1.24	1.24	1.24	1.24	1.23	1.15	1.08	0.98	0.9	0.84	0.78	0.74	0.7	0.67	0.64	0.61	0.59	0.57	0.57
32	2.02	2.02	2.02	2.02	2.02	2.02	2.02	2.02	2.02	2.02	1.88	1.71	1.6	1.5	1.42	1.34	1.28	1.23	1.18	1.13	1.09	1.09
40	3	3	3	3	3	3	3	3	3	3	3	2.9	2.7	2.53	2.4	2.27	2.16	2.07	1.98	1.91	1.84	1.84
50	5.51	5.51	5.51	5.51	5.51	5.51	5.51	5.51	5.51	5.51	5.51	5.51	5.51	5.51	5.38	5.11	4.87	4.65	4.47	4.3	4.15	4.15
65	8.78	8.78	8.78	8.78	8.78	8.78	8.78	8.78	8.78	8.78	8.78	8.78	8.78	8.78	8.78	8.78	8.78	8.67	8.32	8	7.73	7.73
80	12.54	12.54	12.54	12.54	12.54	12.54	12.54	12.54	12.54	12.54	12.54	12.54	12.54	12.54	12.54	12.54	12.54	12.54	12.54	12.54	12.54	12.42
100	22.78	22.78	22.78	22.78	22.78	22.78	22.78	22.78	22.78	22.78	22.78	22.78	22.78	22.78	22.78	22.78	22.78	22.78	22.78	22.78	22.78	22.78
PRESSURE DROP = 30 m HEAD																						
INDEX LENGTH, m																						
DN	5	10	15	20	25	30	35	40	45	50	60	70	80	90	100	110	120	130	140	150	160	
Probable simultaneous flow rate, L/s																						
10	0.14	0.14	0.13	0.11	0.1	0.09	0.08	0.07	0.07	0.07	0.06	0.05	0.05	0.05	0.04	0.04	0.04	0.04	0.04	0.04	0.04	0.03
15	0.28	0.28	0.28	0.27	0.24	0.22	0.2	0.19	0.17	0.16	0.15	0.14	0.13	0.12	0.11	0.11	0.1	0.1	0.09	0.09	0.09	0.09
18	0.45	0.45	0.45	0.45	0.45	0.41	0.38	0.35	0.33	0.31	0.28	0.26	0.24	0.22	0.21	0.2	0.19	0.18	0.18	0.17	0.16	0.16
20	0.68	0.68	0.68	0.68	0.68	0.68	0.66	0.61	0.56	0.54	0.49	0.45	0.42	0.39	0.37	0.35	0.33	0.32	0.3	0.29	0.28	0.28
25	1.24	1.24	1.24	1.24	1.24	1.24	1.24	1.24	1.24	1.2	1.08	0.99	0.93	0.87	0.82	0.78	0.74	0.71	0.68	0.65	0.63	0.63
32	2.02	2.02	2.02	2.02	2.02	2.02	2.02	2.02	2.02	2.02	2.02	1.9	1.77	1.66	1.57	1.49	1.42	1.36	1.3	1.25	1.21	1.21
40	3	3	3	3	3	3	3	3	3	3	3	3	3	2.8	2.64	2.51	2.39	2.29	2.19	2.11	2.04	2.04
50	5.51	5.51	5.51	5.51	5.51	5.51	5.51	5.51	5.51	5.51	5.51	5.51	5.51	5.51	5.51	5.51	5.39	5.15	4.94	4.76	4.59	4.59
65	8.78	8.78	8.78	8.78	8.78	8.78	8.78	8.78	8.78	8.78	8.78	8.78	8.78	8.78	8.78	8.78	8.78	8.78	8.78	8.78	8.78	8.55
80	12.54	12.54	12.54	12.54	12.54	12.54	12.54	12.54	12.54	12.54	12.54	12.54	12.54	12.54	12.54	12.54	12.54	12.54	12.54	12.54	12.54	12.54
100	22.78	22.78	22.78	22.78	22.78	22.78	22.78	22.78	22.78	22.78	22.78	22.78	22.78	22.78	22.78	22.78	22.78	22.78	22.78	22.78	22.78	22.78

Table C.1 (continued)

PRESSURE DROP = 35 m HEAD		INDEX LENGTH, m																					
		5	10	15	20	25	30	35	40	45	50	60	70	80	90	100	110	120	130	140	150	160	
DN		Probable simultaneous flow rate, L/s																					
10	0.14	0.14	0.14	0.14	0.12	0.1	0.09	0.09	0.08	0.08	0.07	0.06	0.06	0.05	0.05	0.05	0.04	0.04	0.04	0.04	0.04	0.04	
15	0.28	0.28	0.28	0.28	0.26	0.26	0.24	0.23	0.2	0.19	0.18	0.16	0.15	0.14	0.13	0.12	0.11	0.11	0.1	0.1	0.1	0.09	
18	0.45	0.45	0.45	0.45	0.45	0.45	0.45	0.41	0.38	0.36	0.34	0.31	0.28	0.26	0.24	0.22	0.21	0.2	0.19	0.18	0.18	0.18	
20	0.68	0.68	0.68	0.68	0.68	0.68	0.68	0.68	0.66	0.62	0.58	0.53	0.49	0.45	0.42	0.38	0.36	0.35	0.33	0.32	0.31	0.31	
25	1.24	1.24	1.24	1.24	1.24	1.24	1.24	1.24	1.24	1.24	1.24	1.18	1.09	1.01	0.94	0.84	0.8	0.77	0.74	0.71	0.69	0.69	
32	2.02	2.02	2.02	2.02	2.02	2.02	2.02	2.02	2.02	2.02	2.02	2.02	2.02	1.93	1.81	1.62	1.54	1.48	1.42	1.36	1.32	1.32	
40	3	3	3	3	3	3	3	3	3	3	3	3	3	3	3	2.88	2.6	2.49	2.39	2.3	2.22	2.22	
50	5.51	5.51	5.51	5.51	5.51	5.51	5.51	5.51	5.51	5.51	5.51	5.51	5.51	5.51	5.51	5.51	5.51	5.51	5.38	5.18	5	5	
65	8.78	8.78	8.78	8.78	8.78	8.78	8.78	8.78	8.78	8.78	8.78	8.78	8.78	8.78	8.78	8.78	8.78	8.78	8.78	8.78	8.78	8.78	
80	12.54	12.54	12.54	12.54	12.54	12.54	12.54	12.54	12.54	12.54	12.54	12.54	12.54	12.54	12.54	12.54	12.54	12.54	12.54	12.54	12.54	12.54	
100	22.78	22.78	22.78	22.78	22.78	22.78	22.78	22.78	22.78	22.78	22.78	22.78	22.78	22.78	22.78	22.78	22.78	22.78	22.78	22.78	22.78	22.78	

## C.2 Procedure

The procedure is as follows:

- Step 1 Draw a sketch of the installation (see [Figure C.3](#)).
- Step 2 Determine the index length. This is the distance, in metres, from the point where the minimum available pressure head is known (e.g. at main tapping or at meter location) to the most distant fixture outlet in the building. This is the only pipe length used for sizing each pipe section.
- Step 3 Determine the pressure drop, in metres head, along the index length using the following equation:

$$\text{Pressure drop} = H_m - H_s - H_x \quad \text{C.2}$$

where

$H_m$  = minimum head available, in metres head

$H_s$  = height of highest fixture outlet (static head loss), in metres

$H_x$  = minimum head required at any fixture outlet, in metres head

NOTE 1: [Clause 3.3.2](#) requires a minimum value of 5 m head; however, some special appliances may require a larger value for satisfactory operation.

- Step 4 Draw up a table with the following headings:

Pipe section	Probable simultaneous demand	Nominal pipe size
	L/s	DN

- Step 5 For each pipe section find the appropriate probable simultaneous demand (PSD) value from [Table 3.2.3](#) and enter the value on [Figure C.3](#) (e.g. three dwellings require 0.88 L/s).
- Step 6 Enter each pipe section to be sized into the table (see Step 4) with the appropriate probable simultaneous demand (PSD) value for this pipe section.
- Step 7 Select the appropriate sizing table corresponding to the pressure drop calculated in Step 3. If the pressure drop falls between two tables, use the table for the lower pressure drop. If the pressure drop calculated in Step 3 is greater than 35 m, use the 35 m table.
- Step 8 Select the index length column that is equal to or greater than the index length calculated in Step 2.
- Step 9 Follow down this column until a probable simultaneous flow rate (PSFR) equal to or greater than the value required for each pipe section is reached. The size of the pipe required is found by reading across this line to the first column marked "DN".

NOTE 2: Flow rates in these tables have been adjusted, where required, to limit water velocity to a maximum of 3.0 m/s.

- Step 10 Enter the size of pipe in the table (Step 4) and continue through Steps 9 and 10 for each pipe section.

## C.3 Worked example

Sizing of the external piping for a group of 12 villa-style home units arranged in three buildings each containing four units on a steeply sloping site.

The minimum available pressure at the main tapping is 30 m head, and the furthest fixture outlet is 13 m above the main. The length of internal piping to this most remote outlet in Unit 12 is 11 m.

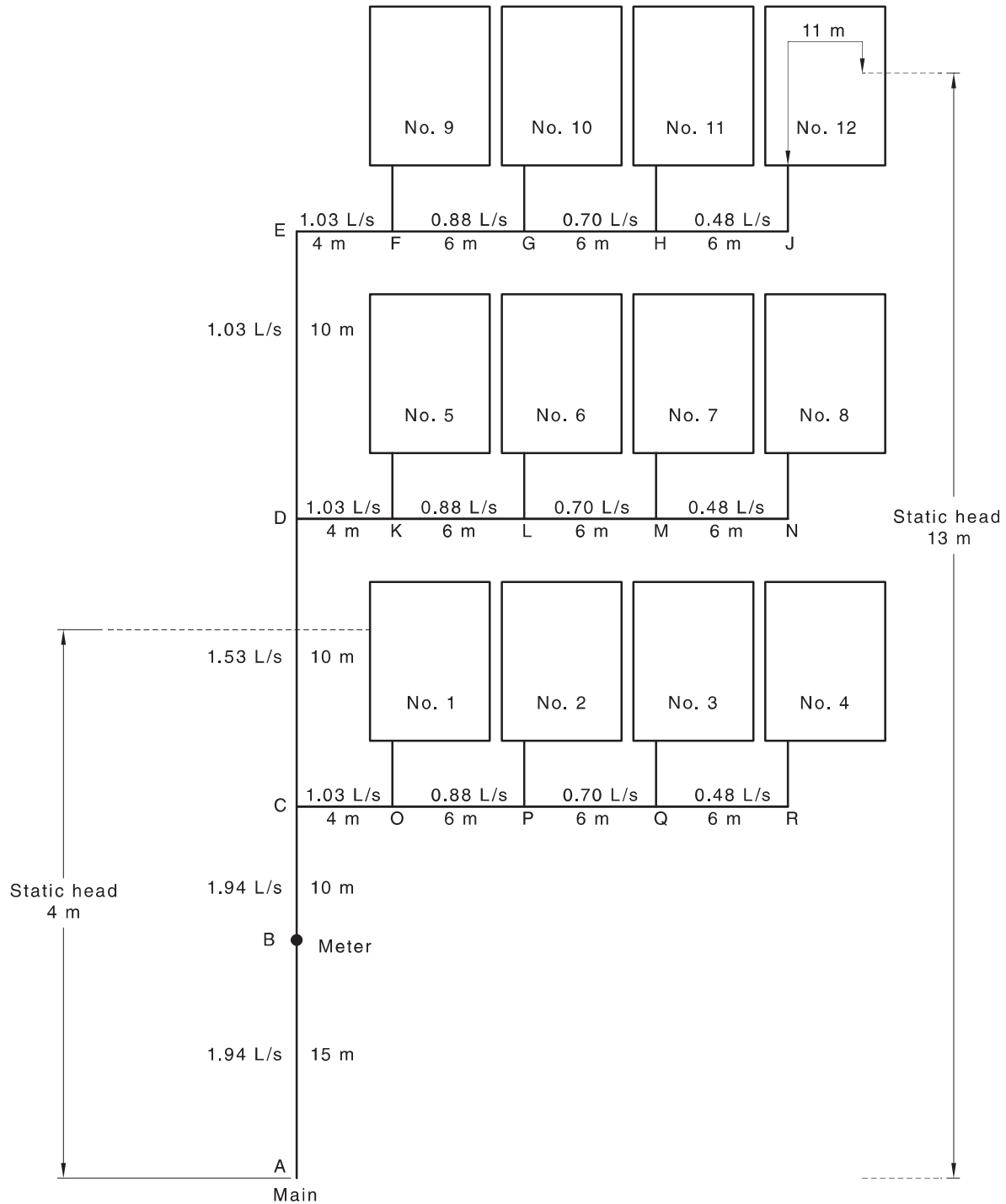

Step 1 Sketch of installation

Figure C.3 — Sketch of installation

Step 2 Index length = AB + BC + CD + DE + EF + FG + GH + HJ + (distance from point J to the most remote fixture)

$$= 15 + 10 + 10 + 10 + 4 + 6 + 6 + 6 + 11$$

$$= 78 \text{ m}$$

Step 3 The minimum head available at the main is 30 m head. The height of the highest fixture outlet in Unit 12 is 13 m above the main. Therefore:

$$\begin{aligned} \text{Pressure drop} &= H_m - H_s - H_x \\ &= 30 - 13 - 5 \\ &= 12 \text{ m head} \end{aligned}$$

Step 4	Pipe section	Probable simultaneous demand (PSD) (see <a href="#">Table 3.2.3</a> )	Nominal pipe size
		L/s	DN
Steps 5 and 6	JH, NM, RQ	0.48	25 Step 10
	HG, ML, QP	0.70	32
	GF, LK, PO	0.88	32
	FE, KD, OC	1.03	40
	ED	1.03	40
	DC	1.53	40
	CB	1.94	50
	BA	1.94	50

Step 7 The pressure drop of 12 m head falls between the 10 m and 15 m head pressure drop tables. Therefore, use 10 m head table.

Step 8 Index length = 78 m, so use 80 m column.

Step 9 For pipe sections JH, NM and RQ the required probable simultaneous flow rate (PSFR) value is 0.48 L/s. The next largest value in the 80 m column is 0.50 L/s and this corresponds to pipe size DN 25, see [Table C.1](#).

Step 10 Enter value of DN 25 in table above and using the same values of pressure drop and index length, proceed to size each other pipe section and enter size in the table.

## Appendix D (informative)

### Sizing of piping for dwellings

#### D.1 General

This appendix provides a method for sizing of piping for the supply of water to single or multiple dwellings and uses the probable simultaneous demand (PSD) values provided in [Table 3.2.3](#).

The method given in this appendix may also be used to size the piping within the dwelling using the concept of loading units. Each branch pipe within the dwelling is assigned a number of loading units, depending on the number and type of fixture outlets it serves. Loading units corresponding to fixtures and appliances are given in column 4 of [Table 3.2.1](#). A table for converting loading units (LU) to probable simultaneous flow rate (PSFR) is given in [Table 3.2.4](#).

#### D.2 Procedure

The procedure is as follows:

- Step 1 Draw a sketch of the internal piping (see [Figure D.3](#)) showing the location of each fixture or appliance together with its appropriate loading units.
- Step 2 Determine the index length. This is the distance, in metres, from the point in the supply line where the minimum available pressure head is known (e.g. main tapping or meter position) to the most distant outlet within the dwelling.
- Step 3 Determine the pressure drop, in metres head, across this index length using the following equation:

$$\text{Pressure drop} = H_m - H_s - H_x \quad \text{D.2}$$

where

$H_m$  = minimum head available, in metres head

$H_s$  = height of the highest outlet within the dwelling, in metres

$H_x$  = minimum head required at any fixture outlet, in metres head

NOTE 1: In the case of multistorey residential dwellings, the index length and pressure drops may be different for each dwelling; however, it may not be necessary to individually size each dwelling where the index lengths and pressure drops are similar for a group of dwellings.

- Step 4 Draw up a table with the following headings:

Pipe section	Loading units	Probable simultaneous flow rate (PSFR)	Nominal pipe size
		L/s	DN

- Step 5 For each pipe section within the dwelling determine the PSFR for that section using the following rules:

- (a) If it supplies only one fixture outlet, the PSFR is the minimum flow rate for that fixture or appliance given in column 2 of [Table 3.2.1](#).
- (b) If it supplies more than one fixture outlet, sum the loading units served by this pipe section and then read off the PSFR corresponding to the total loading units carried from [Table 3.2.4](#).

**Step 6** Enter each pipe section to be sized in your table (see Step 4) with the appropriate loading units and PSFR values. Once the estimated PSFR value is obtained, the pipe size for each section is obtained from [Table C.1](#) using Steps 7 to 10 of [Clause C.2](#).

NOTE 2: The flow rates in [Table C.1](#) have been adjusted, where necessary, to limit the velocity to a maximum of 3.0 m/s.

### D.3 Worked example

A worked example for the sizing of the internal pipework within Units 1 and 12 of the installation used in the example given in [Appendix C](#) is shown below.

**Step 1**

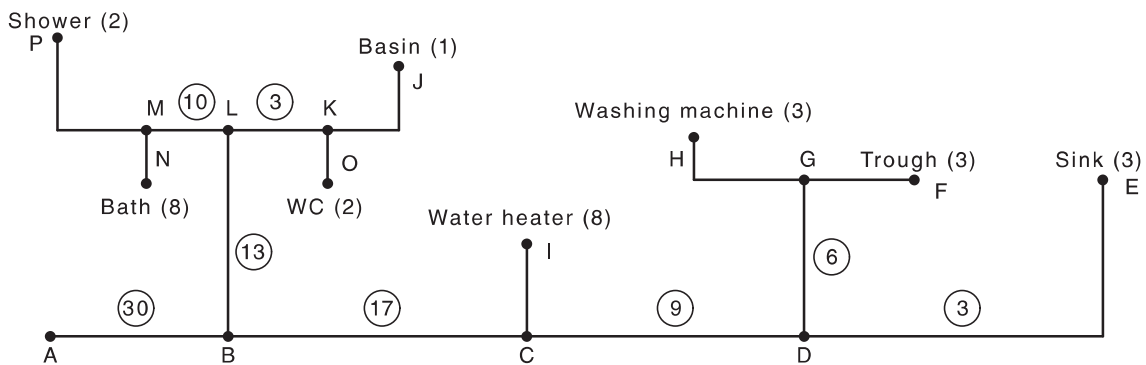

**Figure D.3 — Sketch of installation**

	UNIT 1		UNIT 2		
<b>Step 2</b>	Index length		Index length		
	= 15 + 10 + 4 + 11		= 15 + 10 + 10 + 10 + 4 + 6 + 6 + 6 + 11		
	= 40 m		= 78 m		
<b>Step 3</b>	The height of the highest outlet in Unit 1 is found to be 4 m above the main. Therefore, the static head loss ( $H_s$ ) is 4 m head		The height of the highest outlet in Unit 2 is found to be 13 m above the main. Therefore, the static head loss ( $H_s$ ) is 13 m head		
	<i>Pressure drop</i>		<i>Pressure drop</i>		
	$= H_m - H_s - H_x$		$= H_m - H_s - H_x$		
	$= 30 - 4 - 5$		$= 30 - 13 - 5$		
	$= 21$ m head		$= 12$ m head		
<b>Step 4</b>	Pipe section	Loading units	PSFR, L/s	Nominal pipe size, DN	
	Section	Units	(L/s)	Unit 1	Unit 2

Step 5 Pipe section ED serves one outlet (sink with standard tap). Hence PSFR is 0.12 L/s as per [Table 3.2.1](#), column 2. Pipe section GD serves both washing machine and tub (HF). Hence total loading units are 6 (3 + 3) and PSFR corresponding to 6 loading units is 0.20 L/s as per [Table 3.2.4](#), column 2. Each pipe section is dealt with in turn, proceeding in the opposite direction to the water flow.

Step 6 Completed table is shown at the end of this example (Step 10).

**UNIT 1****UNIT 2**

Step 7 Pressure drop is 21 m head, so use the 20 m head table.

Pressure drop is 12 m head, so use the 10 m head table.

Step 8 Use 40 m column.

Use 80 m column.

Step 9 For section ED, the PSFR is 0.12 L/s and this corresponds to a pipe size of at least DN 15.

For Section ED, the PSFR is 0.12 L/s, and this corresponds to a pipe size of at least DN 18.

Step 10 Completed table

Pipe section	Loading units <sup>a</sup>	PSFR, L/s <sup>b</sup>	Nominal pipe size, DN	
			Unit 1	Unit 12
ED	c	0.12	15	18
FG	c	0.12	15	18
HG	c	0.20	18	20
GD	6	0.20	18	20
DC	9	0.25	18	25
IC	c	0.20	18	20
CB	17	0.35	20	25
JK	c	0.10	15	18
OK	c	0.10	15	18
KL	3	0.14	15	20
PM	c	0.10	15	18
NM	c	0.30	20	25
ML	10	0.26	18	25
LB	13	0.30	20	25
BA	30	0.47	20	25

<sup>a</sup> See [Table 3.2.4](#).

<sup>b</sup> See [Tables 3.2.1](#) and [3.2.4](#).

<sup>c</sup> One outlet only.

NOTE 1 If the pipe supplies only one fixture outlet, the PSFR is the minimum flow rate for that fixture or appliance given in column 2 of [Table 3.2.1](#).

NOTE 2 If the pipe supplies more than one fixture outlet, sum the loading units served by this pipe section and then read off the PSFR corresponding to the total loading units carried from [Table 3.2.4](#).

## Appendix E (informative)

### Examples of potential cross-connections

#### E.1 Scope

This appendix provides some examples of installations in which cross-connections are likely to be encountered.

The methods of cross-connection control are given in [Section 4](#).

#### E.2 Potential cross-connections

Some examples of installations in which cross-connections are likely to occur are as follows:

- (a) *Agricultural and horticultural properties* — Market gardens, poultry farms, and dairy farms, the interconnection between water service and dam water, drinking nipples, fogging sprays, irrigation pipes, antibiotic injectors, cleansing injectors, vertical sprays for vehicle washing, or any submerged outlet or hose at tanks or feed troughs.
- (b) *Catering and allied trade installations* — Commercial kitchens, hotels, and clubs, the interconnection between the water service and water-cooled refrigerant units containing methyl chloride gas, or any submerged outlets or hoses that connect to glass washers, dishwashers, bain-maries, food waste disposal units, garbage can washers, ice-making machines, refrigerators, hoses when supplying water to sinks or other receptacles.
- (c) *Domestic installation* — Interconnection of the water service to a haemodialysis machine, bidet, water-operated venturi type ejectors attached to garden hoses where used to empty or clean out sullage pits, septic tanks, gullies, stormwater sumps, domestic grease traps, or any submerged outlets, or discharge point of the water service in sanitary flushing cisterns, garden hoses supplying water to swimming pools, ornamental ponds, fish ponds, hose taps below the flood level rim of any fixture, or located below the finished surface level.
- (d) *Health and sanitary services installations* — These installations include the following:
  - (i) *Council sanitary depots* — Interconnection between the water service and sanitary pan washers, truck washers, and pan-dumping machines.
  - (ii) *Dental surgeries* — Any submerged water service outlets connected to chair bowls and venturi type water aspirators.
  - (iii) *Funeral parlours* — In embalming areas, the interconnection between the water service outlet and water-operated aspirator pumps.
  - (iv) *Hospitals and nursing homes* — Submerged outlets of the water service at bed pan washers, bed bottle washers, sterilizers, steam autoclaves, instrument washers, and any interconnection between the water service and steam pipes, steam boilers, or steam calorifiers.

- (v) *Mortuaries* — Post-mortem areas, submerged water service outlets at autopsy tables, flushing rim floor gullies, specimen tables, and instrument washing sinks.
- (e) *Industrial and commercial installations* — These installations include the following:
- (i) *Tanks* — Any submerged discharge point of hoses or pipes that supply water to rinse tanks, process tanks and other tanks.
  - (ii) *Abattoirs* — Interconnection between the water service and steam pipes, steam boilers, or steam calorifiers, and the washing sprays in contact with animal carcasses.
  - (iii) *Bleaching works* — Interconnection between the water service and steam pipes, steam boilers, steam calorifiers, or any submerged outlets at revolving drum washers, or any pipes conveying non-drinking water.
  - (iv) *Breweries, cordial and soft drink plants* — Interconnection between water service and the contents of gas cylinders, steam pipes, steam boilers, or steam calorifiers, or any submerged water service outlets at drum or bottle washers, process tanks.
  - (v) *Butchers' shops* — Interconnection between the water service and any water-cooled refrigerant units containing methyl-chloride gas, or water-powered food processing machines.
  - (vi) *Chemical plants* — Interconnection between the water service and chemical pipelines, or the submerged water service pipe outlets at drum washer and process tanks.
  - (vii) *Dry cleaners* — Interconnection between the water service and solvent stills.
  - (viii) *Dyeing works* — Interconnection between the water service pipes and steam pipes, foul water inlet sprays in process tanks, and any submerged water service pipe outlets at vats, tanks, and colanders.
  - (ix) *Engineering works* — Interconnection between the water service and any steam boilers, diesel oil recirculating systems, recirculated cooling water for machines, testing pressure vessels, oil cooling coils, pump priming, compressed air pipelines, and venturi type ejectors in vehicle maintenance pits.
  - (x) *Laboratories* — Interconnection between the water service and any aspirator pumps, fume cupboards, stills, centrifuges, blood testing machines, air scrubbers, test-tube washing machines, animal feeding troughs, and high-pressure gas cylinders.
  - (xi) *Laundries* — Interconnection between the water service and any clothes washing machines, starch tanks, soap mixing vats, and recirculated heated water tanks.
  - (xii) *Milk processing plants* — Interconnection between the water service and any steam pipes, steam boilers, steam calorifiers, or any submerged outlets at bottle washing machines, milk can washing machines, and process chilling tanks.
  - (xiii) *Oil storage depots* — Interconnection between the water service and foam firefighting equipment.
  - (xiv) *Poultry processing plants* — Interconnection between the water service and any steam pipes, steam boilers, steam calorifiers, or any submerged outlets at feather-plucking machines, carcass-washing machines, offal boilers, and process tanks.
  - (xv) *Photographic developers* — Interconnection between the water service and X-ray equipment, or any submerged outlets at tanks and rinse machines.
  - (xvi) *Plating workings* — Interconnection between the water service and solvent, acid or alkaline tanks, cooling coils, steam pipes, or any submerged outlets at tanks and rinse machines.

- (xvii) *Tanneries* — Interconnection between the water service and vats, drum process tanks, or steam pipes.
- (xviii) *Wool processors* — Interconnection between the water service and lanolin centrifuges and head recycling coils, or any submerged outlets or hoses at vats, drums, and tanks.

## Appendix F (informative)

### Storage tanks — Inflow and overflow

#### F.1 General

This appendix contains an example of the calculations for inflow rate, overflow size, spill level air gap and height of inlet above invert of overflow for storage tanks.

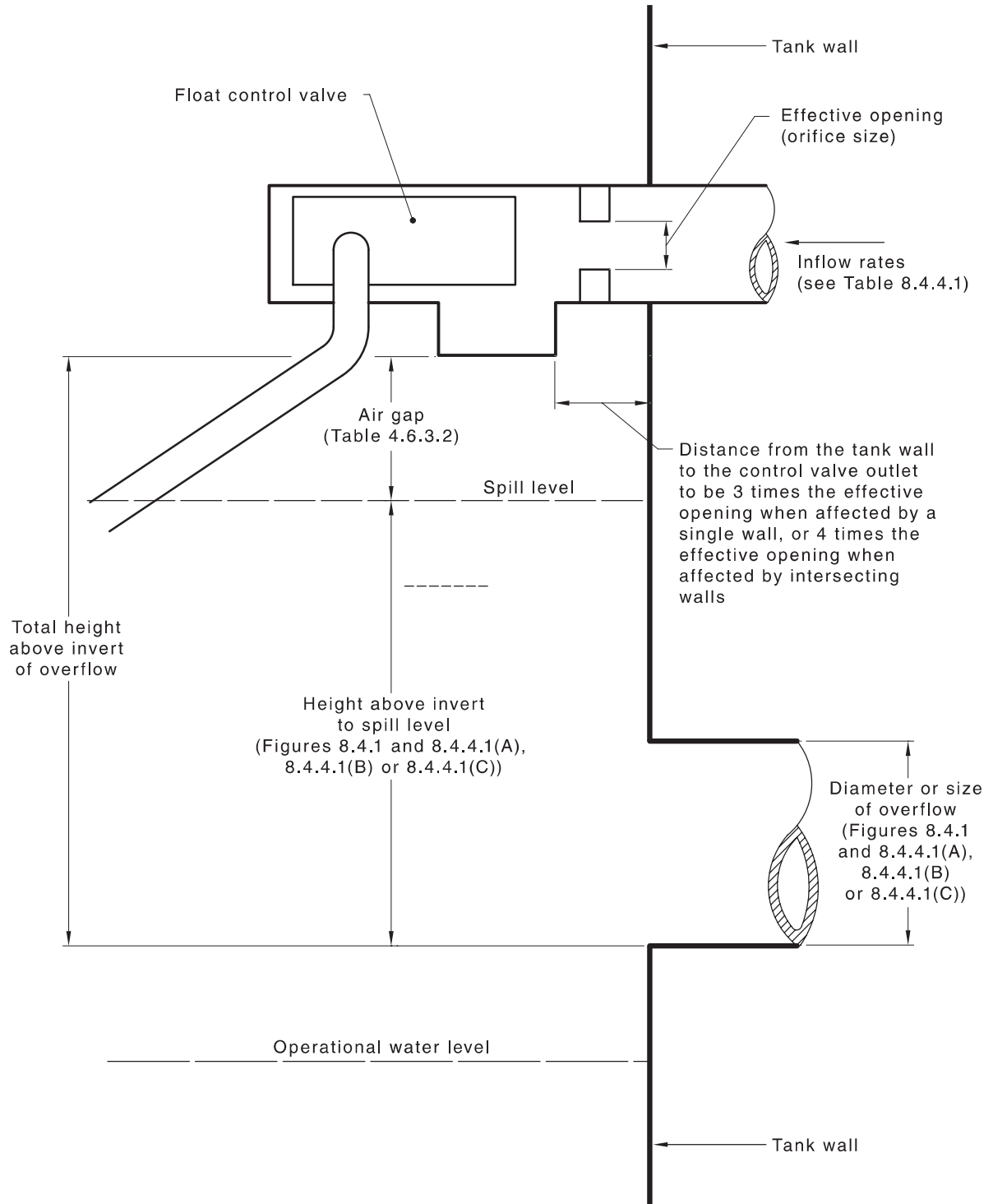

**Figure F.1 — Distances related to overflow size, spill level, and air gap**

## F.2 Inflow rate

Inflow rates may be determined from [Table 8.4.4.1](#). As an example, the inflow rate from a 20 mm orifice with an inlet pressure of 500 kPa would be 6.0 L/s.

### F.3 Overflow size and spilling level

With reference to [Figure 8.4.1](#) and [Figures 8.4.4.1\(A\)](#) to [8.4.4.1\(C\)](#), depending on the type of overflow, determine the size of overflow and spill level required from the alternative available.

For this example, [Figure 8.4.4.1\(A\)](#) is used. Using the inflow rate determined from [Clause F.2](#) (i.e. 6.0 L/s) select combination required. The available alternatives are given in [Table F.1](#).

**Table F.1 — Spill levels**

Internal diameter of overflow pipe mm	Spill level (height of water above invert of overflow) mm
100	150
125	125
150	100

### F.4 Air gap

With reference to [Table 4.6.3.2](#), the minimum air gap for a 20 mm orifice, when not affected by a near wall, is 40 mm (see [Figure F.1](#)).

### F.5 Height of inlet above invert level of overflow

The height of the float control valve outlet above the invert of the overflow is determined by the addition of the spill level ([Clause F.3](#)) and the air gap ([Clause F.4](#)).

## Appendix G (normative)

### Cleaning and disinfection of storage tanks

#### G.1 General

All water storage tanks for drinking water shall be cleaned and disinfected —

- (a) prior to initial use; and
- (b) whenever the tank is taken out of service for inspection, repairs, painting or other activity that might lead to contamination of water.

#### G.2 Cleaning

The tank shall be drained and all debris and sludge removed. The surfaces of walls, floor and operating facilities shall be thoroughly cleaned using a high-pressure water jet, sweeping, scrubbing or other similar effective means. All water, dirt, and other material accumulated in this cleaning process shall be flushed or otherwise removed from the tank.

#### G.3 Disinfection

After cleaning, the tank shall be disinfected by one of the following means:

- (a) Filling the tank to overflow level with drinking water to which enough chlorine is added to provide a free chlorine residual, in the whole tank, of not less than 10 mg/L at the end of the retention time (see Note 1).

The retention time shall be not less than 6 h, when the water entering the tank has been chlorinated uniformly by gas-fed equipment or chemical pump, or not less than 24 h, when the storage tank has been filled with water that has been mixed with sodium hypochlorite or calcium hypochlorite within the storage facility.

The tank shall be drained after disinfection and flushed out with drinking water prior to being put back into service.

- (b) Application of 200 mg/L available chlorine directly to all surfaces of the storage tank.

The disinfection solution shall remain in contact with the surface for at least 30 min. The tank surfaces shall then be hosed down and flushed with drinking water prior to being put back into service.

NOTE 1 The amount of chlorine to be added to obtain 10 mg/L residual after the retention period will depend on the amount of organic material present and the chemical composition of the water. As a guide, an initial chlorine dose of 50 mg/L is recommended.

NOTE 2 Amounts of common chlorine, including agents required per 1 000 L should be as follows:

NOTE 3 Authorities may require chlorinated water to be neutralized before discharging to the environment.

NOTE 4 Authorities may require collection and disposal of sludge and silts separately.

NOTE 5 ANSI/AWWA C652 contains details of disinfection methods that may be used together with an appendix on neutralization of chlorinated water.

NOTE 6 Choice of the method of disinfection used should include consideration of the size of the tank to be disinfected, the availability of materials and disinfection equipment, training of personnel, safety of operation and disposal of chlorinated water.

<b>Chlorine dose</b> <b>mg/L</b>	<b>12.5 % Sodium hypochlorite</b> <b>solution</b> <b>mL</b>	<b>70 % Calcium hypochlorite</b> <b>g</b>
50	400	70
200	1 600	280

## Appendix H (normative)

### Disinfection of water services

#### H.1 General

Water services that are used to supply drinking water shall be protected against contamination during storage, construction and repairs, and flushed and chlorinated before being placed in service and after any repairs that might lead to contamination of water.

#### H.2 Precautions against contamination

Precautions shall be taken to protect the interior of pipes fittings and valves against contamination during storage, construction and repairs.

NOTE See [Clause H.5](#) Note 1.

#### H.3 Flushing of water services

On completion of installation or repairs, water services shall be flushed at each discharge point to remove any dirty water or debris from the service. The flushing velocity in any section of the service shall be not less than 0.75 m/s.

#### H.4 Chlorination

After flushing, water services from storage tanks shall be chlorinated, before being placed in service, as follows:

- (a) Water services from storage tanks shall be disinfected by drawing chlorinated water from the storage tank into the service, such that after a retention period of 6 h, a free chlorine residual of not less than 10 mg/L is obtained throughout the services.

NOTE 1 See [Clause H.5](#) Note 2.

- (b) Water services DN 80 or larger, shall be disinfected as for water services from storage tank or in accordance with ANSI/AWWA C651.

NOTE 2 Refer to ANSI/AWWA C651 for information on disinfecting water mains.

#### H.5 Final flushing

After the applicable retention period, heavily chlorinated water shall not be allowed to remain in prolonged contact with service piping. In order to prevent damage to pipe lining or corrosion to pipe itself, the heavily chlorinated water shall be flushed from the service until chlorine measurements show that the concentration in the water leaving the service is no higher than that generally prevailing in the authority's distribution system.

NOTE 1 During construction, all openings in pipelines should be covered and, when laid in a trench, sealed with watertight plugs during interruption to installation to prevent contamination from water in the trench.

NOTE 2 Water services that are supplied from storage tanks should be disinfected at the same time as that of the disinfection of the storage tank. The water service to the tank should be closed. The discharge points on the service from the tank then be opened, working progressively away from the storage tank until chlorinated water (as detected by odour) is delivered from each discharge point, which should then be closed. The storage tanks should then be topped up with chlorinated water.

## Bibliography

- AS 1172.2, *Sanitary plumbing products, Part 2: Flushing devices and cistern inlet and outlet valves*
- AS 1319, *Safety signs for the occupational environment*
- AS 1379, *Specification and supply of concrete*
- AS 1397, *Continuous hot-dip metallic coated steel sheet and strip — Coatings of zinc and zinc alloyed with aluminium and magnesium*
- AS 1432, *Copper tubes for plumbing, gasfitting and drainage applications*
- AS 1478.1, *Chemical admixtures for concrete, mortar and grout, Part 1: Admixtures for concrete*
- AS 1604.1, *Specification for preservative treatment, Part 1: Sawn and round timber*
- AS 1646, *Elastomeric seals for waterworks purposes*
- AS 1657, *Fixed platforms, walkways, stairways and ladders — Design, construction and installation*
- AS 2118.1, *Automatic fire sprinkler systems, Part 1: General systems*
- AS 2118.2, *Automatic fire sprinkler systems, Part 2: Drencher systems*
- AS 2118.3, *Automatic fire sprinkler systems, Part 3: Deluge systems*
- AS 2118.4, *Automatic fire sprinkler systems, Part 4: Sprinkler protection for accommodation buildings not exceeding four storeys in height*
- AS 2118.5, *Automatic fire sprinkler systems, Part 5: Home fire sprinkler systems*
- AS 2118.6, *Automatic fire sprinkler systems, Part 6: Combined sprinkler and hydrant systems in multistorey buildings*
- AS 2129, *Flanges for pipes, valves and fittings*
- AS 2441, *Installation of fire hose reels*
- AS 2700, *Colour Standards for general purposes*
- AS 2865, *Confined spaces*
- AS 2941, *Fixed fire protection installations — Pumpset systems*
- AS 3600, *Concrete structures*
- AS 3660.1, *Termite management, Part 1: New building work*
- AS 3688, *Water supply and gas systems — Metallic fittings and end connectors*
- AS 3795, *Copper alloy tubes for plumbing and drainage applications*
- AS 4176 (all parts), *Multilayer pipes for pressure applications*
- AS 5082.1, *Polybutylene (PB) plumbing pipe systems — Metric series, Part 1: Metric polybutylene (PB) pipes for hot and cold water applications*
- AS 5082.2, *Polybutylene (PB) plumbing pipe systems — Metric series, Part 2: Mechanical and fusion jointing systems*

- AS 5200.053, *Plumbing and drainage products, Part 053: Stainless steel pipes and tubes for pressure applications*
- AS/NZS 1167.1, *Welding and brazing — Filler metals, Part 1: Filler metal for brazing and braze welding*
- AS/NZS 1167.2, *Welding and brazing — Filler metals, Part 2: Filler metal for welding*
- AS/NZS 1477, *PVC pipes and fittings for pressure applications*
- AS/NZS 2280, *Ductile iron pipes and fittings*
- AS/NZS 2492, *Cross-linked polyethylene (PE-X) pipes for pressure applications*
- AS/NZS 2537 (all parts), *Mechanical jointing fittings for use with crosslinked polyethylene (PE-X) for pressure applications*
- AS/NZS 2544, *Grey iron pressure fittings*
- AS/NZS 2642.2, *Polybutylene (PB) plumbing pipe systems, Part 2: Polybutylene (PB) pipe for hot and cold water applications*
- AS/NZS 2642.3, *Polybutylene (PB) plumbing pipe systems, Part 3: Mechanical jointing fittings for use with polybutylene (PB) pipes for hot and cold water application*
- AS/NZS 2845.1, *Water supply — Backflow prevention devices, Part 1: Materials, design and performance requirements*
- AS/NZS 2878, *Timber — Classification into strength groups*
- AS/NZS 3000, *Electrical installations (known as the Australian/New Zealand Wiring Rules)*
- AS/NZS 3500.2, *Plumbing and drainage, Part 2: Sanitary plumbing and drainage*
- AS/NZS 3518, *Acrylonitrile butadiene styrene (ABS) compounds, pipes and fittings for pressure applications*
- AS/NZS 3718, *Water supply — Tap ware*
- AS/NZS 4020, *Testing of products for use in contact with drinking water*
- AS/NZS 4087, *Metallic flanges for waterworks purposes*
- AS/NZS 4129, *Fittings for polyethylene(PE) pipes for pressure applications*
- AS/NZS 4130, *Polyethylene (PE) pipes for pressure applications*
- AS/NZS 4331.1, *Metallic flanges, Part 1: Steel flanges*
- AS/NZS 4331.2, *Metallic flanges, Part 2: Cast iron flanges*
- NZS 3109, *Concrete construction*
- NZS 3124, *Specification for concrete construction for minor works*
- NZS 3501, *Specification of copper tubes for water, gas and sanitation*
- NZS 3631, *New Zealand Timber Grading Rules*
- NZS 3640, *Chemical preservation of round and sawn timber*
- NZS 4510, *Fire hydrant systems for buildings*
- NZS 4515, *Fire sprinkler systems for life safety in sleeping occupancies (up to 2000 square metres)*
- NZS 4517, *Fire sprinkler systems for houses*

- NZS 4541, *Automatic fire sprinkler systems*
- ISO 15874-2, *Plastics piping systems for hot and cold water installations — Polypropylene (PP) — Part 2: Pipes*
- ISO 15874-3, *Plastics piping systems for hot and cold water installations — Polypropylene (PP) — Part 3: Fittings*
- BS 5422, *Method for specifying thermal insulating materials for pipes, tanks, vessels, ductwork and equipment operating within the temperature range -40°C to +700°C*
- ANSI/AWWA C217, *Microcrystalline wax and petrolatum tape coating systems for steel water pipe and fittings*
- ANSI/AWWA C652, *Disinfection of water storage facilities*
- ASTM A182/A182M, *Standard specification for forged or rolled alloy and stainless steel pipe flanges, forged fittings, and valves and parts for high-temperature service*
- enHealth, *Guidance on use of rainwater tanks*
- National Construction Code (NCC) Volume 3, *Plumbing Code of Australia*
- New Zealand Building Code (NZBC), *Clause B1 Structure*
- New Zealand Building Code (NZBC), *Clause G12 Water Supplies*
- New Zealand Building Code (NZBC), *Clause G1 Personal Hygiene*

## NOTES

### **Standards Australia**

Standards Australia is an independent company, limited by guarantee, which prepares and publishes most of the voluntary technical and commercial standards used in Australia. These standards are developed through an open process of consultation and consensus, in which all interested parties are invited to participate. Through a Memorandum of Understanding with the Commonwealth government, Standards Australia is recognized as Australia's peak national standards body.

### **Standards New Zealand**

The first national Standards organization was created in New Zealand in 1932. The New Zealand Standards Executive is established under the Standards and Accreditation Act 2015 and is the national body responsible for the production of Standards.

### **Australian/New Zealand Standards**

Under a Memorandum of Understanding between Standards Australia and Standards New Zealand, Australian/New Zealand Standards are prepared by committees of experts from industry, governments, consumers and other sectors. The requirements or recommendations contained in published Standards are a consensus of the views of representative interests and also take account of comments received from other sources. They reflect the latest scientific and industry experience. Australian/New Zealand Standards are kept under continuous review after publication and are updated regularly to take account of changing technology.

### **International Involvement**

Standards Australia and Standards New Zealand are responsible for ensuring that the Australian and New Zealand viewpoints are considered in the formulation of international Standards and that the latest international experience is incorporated in national and Joint Standards. This role is vital in assisting local industry to compete in international markets. Both organizations are the national members of ISO (the International Organization for Standardization) and IEC (the International Electrotechnical Commission).

### **Visit our websites**

[www.standards.org.au](http://www.standards.org.au) [www.standards.govt.nz](http://www.standards.govt.nz)



GPO Box 476 Sydney NSW 2001  
Phone (02) 9237 6000  
mail@standards.org.au  
www.standards.org.au



PO Box 1473 Wellington 6140  
Free phone 0800 782 632  
enquiries@standards.govt.nz  
www.standards.govt.nz