

AS/NZS 3500.4:2021



Australian/New Zealand Standard™

# Plumbing and drainage

Part 4: Heated water services



AS/NZS 3500.4:2021

This Joint Australian/New Zealand Standard™ was prepared by Joint Technical Committee WS-014, Plumbing and Drainage. It was approved on behalf of the Council of Standards Australia on 7 May 2021 and by the New Zealand Standards Approval Board on 7 April 2021.

This Standard was published on 28 May 2021.

The following are represented on Committee WS-014:

- Association of Hydraulic Services Consultants Australia
- Australian Building Codes Board
- Australian Industry Group
- Australian Stainless Steel Development Association
- Backflow Prevention Association of Australia
- Engineers Australia
- Hydraulic Consultants Association Australasia
- Institute of Plumbing Australia
- International Copper Association Australia
- Master Plumbers Australia and New Zealand
- Master Plumbers, Gasfitters and Drainlayers New Zealand
- Ministry of Business, Innovation and Employment (NZ)
- Plastics Industry Pipe Association of Australia
- Plastics New Zealand
- Plumbers, Gasfitters and Drainlayers Board (NZ)
- Plumbing Distributors Association of New Zealand
- Plumbing Products Industry Group
- Water New Zealand
- Water Services Association of Australia

This Standard was issued in draft form for comment as DR AS/NZS 3500.4:2020.

### **Keeping Standards up-to-date**

Ensure you have the latest versions of our publications and keep up-to-date about Amendments, Rulings, Withdrawals, and new projects by visiting:

[www.standards.org.au](http://www.standards.org.au)

[www.standards.govt.nz](http://www.standards.govt.nz)

ISBN 978 1 76113 349 7

Australian/New Zealand Standard™

# Plumbing and drainage

## Part 4: Heated water services

First published as AS CA51—1968.  
Revised and redesignated as AS 1529—1974.  
AS 1529—1974 and AS 2002—1987 revised, amalgamated and redesignated  
AS 3500.4—1990.  
AS 3500.4—1990 jointly revised and redesignated AS/NZS 3500.4.2:1997.  
AS/NZS 3500.4.2:1997 jointly revised and redesignated as AS/NZS 3500.4:2003.  
Third edition 2021.

© Standards Australia Limited/the Crown in right of New Zealand, administered by the New Zealand Standards Executive 2021

All rights are reserved. No part of this work may be reproduced or copied in any form or by any means, electronic or mechanical, including photocopying, without the written permission of the publisher, unless otherwise permitted under the Copyright Act 1968 (Cth) or the Copyright Act 1994 (New Zealand).

## Preface

This document was prepared by the joint Standards Australia/Standards New Zealand Committee WS-014, Plumbing and Drainage, to supersede AS/NZS 3500.4:2018.

The objective of this document is to provide Deemed-to-Satisfy solutions for compliance with —

- (a) the National Construction Code (NCC) Volume Three, Plumbing Code of Australia (PCA), and
- (b) the New Zealand Building Code (NZBC), Clause G12 Water Supplies.

A list of all parts in the AS/NZS 3500 series for plumbing and drainage can be found in the Standards Australia and Standards New Zealand online catalogues.

The major changes in this revision are as follows:

- (i) Conformance to individual product standards has been removed. All products used in plumbing and drainage systems in Australia need to comply with the PCA and, in New Zealand, the NZBC, see [Appendix B](#) for further information. Removal of specific product standard conformance requirements avoids inconsistencies and contradictions between this document and the PCA and NZBC
- (ii) Definitions have been relocated to AS/NZS 3500.0 for consistency across the series.
- (iii) Jointing requirements for plastics pipes have been clarified and expanded to allow different methods.
- (iv) Changes to the requirements for the marking of pipes in commercial buildings to assist in the better identification of pipework and avoid cross connections.
- (v) Changes to the requirements for the installation of water services located in metal-framed walls to bring the provisions in line with those of the National Association of Steel-Framed Housing (NASH).
- (vi) The separation between above-ground heated water services pipe work and electrical services has been reduced to bring it in line with AS/NZS 3000 and AS/NZS 3500.1.
- (vii) To improve the amenity of users and reduce wastage of water and energy, changes have been made to requirements for circulated heated water systems including water meters and entry points for heated water, thermal insulation for non-circulatory heated water piping, and maximum capacities of any dead leg from the branch offtake to its termination. [Appendix Q](#) has been added to provide a guide to determining capacity of dead legs and estimating wait times.
- (viii) Heated water temperature control provisions, which are considered matters of public policy, were elevated from AS/NZS 3500.4 to the PCA Part B2 Heated Water Systems. To avoid conflict between the PCA and this document, clauses relating to sanitary fixtures delivery temperature and solutions for control of delivery temperatures have been deleted. In New Zealand, these provisions are contained within NZBC Acceptable Solution G12/AS1.

The terms “normative” and “informative” are used in Standards to define the application of the appendices to which they apply. A “normative” appendix is an integral part of a Standard, whereas an “informative” appendix is only for information and guidance.

Notes or footnotes to tables or figures that are expressed in mandatory terms are deemed to be requirements of this document.

Notes to clauses in this document are informative only and do not include requirements.

*This document includes commentary on some of the clauses. The commentary directly follows the relevant clause, is designated by "C" preceding the clause number, and is printed in italics in a box. The commentary is for information and guidance and does not form part of the document.*

# Contents

<b>Preface</b> .....	<b>ii</b>
<b>Section 1 Scope and general</b> .....	<b>1</b>
1.1 Scope.....	1
1.2 Application.....	1
1.2.1 Australia.....	1
1.2.2 New Zealand.....	1
1.3 Normative references.....	1
1.4 Terms and definitions.....	2
1.5 Plastics abbreviations.....	2
1.6 Water chemistry.....	3
1.7 Pipe sizes.....	3
1.8 Velocity requirements.....	4
1.9 Pressure requirements.....	4
1.9.1 Available pressure.....	4
1.9.2 Pressure at outlets.....	4
1.9.3 Pressure losses.....	5
1.9.4 Pressure booster pumps.....	5
1.10 Flow rates.....	5
1.11 Water temperature.....	5
1.11.1 General.....	5
1.11.2 Storage temperature.....	5
<b>Section 2 Materials and products</b> .....	<b>6</b>
2.1 Scope of section.....	6
2.2 General.....	6
2.3 Pipes and fittings — General limitations.....	6
2.4 Metallic pipes and fittings.....	6
2.4.1 Heated water services.....	6
2.4.2 Limitations.....	7
2.5 Plastics pipes and fittings.....	7
2.5.1 Heated water services.....	7
2.5.2 Limitations.....	8
2.6 Safe tray and safe waste materials.....	8
2.6.1 Safe tray.....	8
2.6.2 Safe wastes.....	8
2.7 Joints.....	9
2.7.1 Flanged joints.....	9
2.7.2 Elastomeric seals.....	9
2.7.3 Silver brazing alloy.....	9
2.7.4 Filler rods for stainless steel joints.....	9
2.8 Miscellaneous materials.....	10
2.8.1 Concrete mix.....	10
2.8.2 Cement mortar.....	10
2.8.3 Water for concrete and mortar.....	10
2.8.4 Timber.....	10
2.8.5 External protective coatings.....	10
<b>Section 3 Cross-connection and backflow prevention and thermostatic mixing valves</b> .....	<b>12</b>
3.1 Scope of section.....	12
3.2 Cross-connection control and backflow prevention.....	12
3.3 Thermostatic mixing valves.....	12
<b>Section 4 Installation of cold and heated water piping and controls</b> .....	<b>14</b>
4.1 Scope of section.....	14
4.2 Installation of pipes and fittings.....	14
4.3 Proximity to other services.....	14

4.3.1	General	14
4.3.2	Electrical cables, gas pipes and other services	14
4.3.3	Crossover of underground services	15
4.4	Methods of jointing	15
4.4.1	General	15
4.4.2	Compression joints	16
4.4.3	Silver brazing	16
4.4.4	Flanged joints	16
4.4.5	Roll-grooved joints	16
4.4.6	Jointing of copper and copper alloy pipes	16
4.4.7	Jointing of stainless-steel pipe and fittings	16
4.4.8	Jointing of plastics pipes	17
4.5	Support and fixing above ground	18
4.5.1	General	18
4.5.2	Brackets, clips and hangers	18
4.5.3	Limitations on pipe supports	18
4.5.4	Spacing	18
4.5.5	Securing of pipes and fittings	19
4.6	Location of piping	19
4.6.1	Concealed piping	19
4.6.2	Protection during building construction	24
4.6.3	Floor or roof penetrations	24
4.6.4	Provision for movement of encased piping	24
4.7	Bedding and backfill	24
4.8	Contaminated areas — Installation	25
4.9	Corrosive areas	25
4.10	Depth of cover	25
4.10.1	Depth of cover in public areas	25
4.10.2	Depth of cover in private areas	26
4.11	Protection against freezing	26
4.11.1	Requirement for protection	26
4.11.2	Piping located outside buildings	26
4.11.3	Pipes located on metal roofs	26
4.11.4	Pipes located inside buildings	27
4.11.5	Insulation of piping and fittings	27
4.12	Cold water piping and storage tanks	28
4.12.1	General	28
4.12.2	Cold water storage tank	28
4.12.3	Safe tray for cold water storage tanks	31
4.12.4	Support for separately mounted cold water storage tanks	31
4.13	Installation of heated water services	31
4.13.1	Design and installation	31
4.13.2	Identification of piping	32
4.13.3	Provision for expansion	32
4.13.4	Gradient	32
4.13.5	Maximum rise of heated water supply pipes	33
4.13.6	Shower assemblies	33
4.13.7	Venting of secondary circuit	33
4.13.8	Recirculation of cold water	33
<b>Section 5</b>	<b>Installation of water heaters — General requirements</b>	<b>35</b>
5.1	Scope of section	35
5.2	Water heaters	35
5.2.1	Selection of anode	35
5.2.2	Working pressure	35
5.3	Location	35
5.3.1	Placement	35
5.3.2	Accessibility and clearances	35
5.3.3	Ventilation and fluing	36

5.4	Protection against damage from leaking water .....	36
5.4.1	Concealed water storage tanks .....	36
5.4.2	Unconcealed water storage tanks .....	36
5.4.3	Safe tray construction .....	36
5.4.4	Safe wastes .....	36
5.4.5	Placement of water heater or cold water storage tank on a safe tray .....	37
5.5	Support .....	38
5.5.1	Support of water storage tanks installed in a roof .....	38
5.5.2	Support of water heaters or water storage tanks installed above a roof .....	40
5.5.3	Support of water heaters or water storage tanks installed other than in a roof space or above a roof .....	41
5.5.4	Seismic restraints .....	42
5.6	Corrosion prevention and weather protection .....	42
5.6.1	Water heater base — Corrosion avoidance .....	42
5.6.2	Weather protection of externally installed water heaters .....	42
5.7	Connections to water heaters .....	43
5.8	Pressure relief and venting of water heaters and containers .....	43
5.9	Valves and expansion vessels .....	43
5.9.1	General .....	43
5.9.2	Required set pressure of valves (for unvented water heaters) .....	45
5.9.3	Set pressure of expansion vessels .....	45
5.9.4	Installation of valves and expansion vessels .....	45
5.10	Multiple installations of pressure-type storage water heaters .....	50
5.10.1	General .....	50
5.10.2	Balanced flow conditions .....	50
5.10.3	Location and sizing of control valves and expansion vessels on the cold water supply .....	53
5.11	Temperature/pressure-relief valve and expansion control valve drain lines .....	53
5.11.1	Size and material .....	53
5.11.2	Interconnection of drain lines .....	54
5.11.3	Installation .....	54
5.11.4	Common stack discharge .....	58
5.11.5	Tundish drain lines .....	58
5.11.6	Areas subject to freezing .....	58
5.12	Vent pipes .....	58
5.12.1	Installation .....	58
5.12.2	Termination of vent pipe .....	58
5.12.3	Cold water storage tank-fed water heaters (other than side-fed types) .....	59
5.12.4	Vented storage water heaters, inlet pressure-controlled .....	59
<b>Section 6</b>	<b>Installation of solar water heaters .....</b>	<b>60</b>
6.1	Scope of section .....	60
6.2	Application of section (New Zealand only) .....	60
6.3	General installation requirements .....	60
6.3.1	Sizing and solar performance .....	60
6.3.2	Location .....	60
6.3.3	Structural integrity .....	61
6.3.4	Water hardness and dissolved solids .....	61
6.3.5	Collector circuit .....	61
6.3.6	Flow and return pipes and fittings .....	61
6.3.7	Corrosion resistance .....	62
6.3.8	Entrapped air .....	62
6.3.9	Over-temperature protection .....	62
6.3.10	Pressure and temperature relief .....	62
6.3.11	Drain lines .....	62
6.3.12	Unintentional circulation .....	62
6.3.13	Mounting .....	63
6.3.14	Supplementary heating .....	63
6.3.15	Penetrations through roof cladding .....	63

6.4	Installation of solar water heater storage containers.....	63
6.4.1	General.....	63
6.4.2	Thermosiphon systems.....	63
6.4.3	Support.....	63
6.4.4	Safe trays.....	64
6.4.5	Auxiliary water heating.....	64
6.5	Installation of collectors.....	65
6.5.1	Positioning.....	65
6.5.2	Precautions.....	69
6.6	Solar water heaters with remote containers.....	69
6.6.1	Pumps and controllers.....	69
6.6.2	Pump and controller installation.....	70
<b>Section 7</b>	<b>Uncontrolled heat sources.....</b>	<b>72</b>
7.1	Scope of section.....	72
7.2	Water heaters with uncontrolled energy source.....	72
7.2.1	Installation.....	72
7.2.2	Supplementary external heating.....	74
7.2.3	Provision for drainage.....	74
<b>Section 8</b>	<b>Energy efficiency.....</b>	<b>75</b>
8.1	Scope of section.....	75
8.2	Thermal insulation.....	75
8.2.1	Piping associated with storage water heaters.....	75
8.2.2	Other piping for heated water systems.....	76
8.3	Protection of insulation.....	77
8.3.1	Insulation exposed to the weather.....	77
8.3.2	Protection of thermal insulation on buried piping.....	77
8.4	Heat traps.....	77
8.5	R-value calculations.....	78
<b>Section 9</b>	<b>Testing and commissioning.....</b>	<b>79</b>
9.1	Scope of section.....	79
9.2	Flushing.....	79
9.3	Testing.....	79
9.4	Commissioning.....	79
9.5	Heated water circulating system diagram.....	80
9.6	Operating instructions.....	83
<b>Section 10</b>	<b>Sizing and installation of circulatory heated water reticulation.....</b>	<b>84</b>
10.1	Scope of section.....	84
10.2	Temperature requirements.....	84
10.3	Flow requirements.....	84
10.3.1	General.....	84
10.3.2	Flow rates.....	84
10.3.3	Loading units.....	85
10.3.4	Continuous demand outlets.....	85
10.3.5	Probable simultaneous demand.....	85
10.3.6	Probable simultaneous flow rate.....	85
10.4	Maximum pressure requirements.....	86
10.4.1	Maximum pressure within buildings.....	86
10.4.2	Maximum differential.....	86
10.5	Pressure requirements for circulatory heated water systems.....	86
10.6	Velocity requirements.....	87
10.6.1	Circulating pumps.....	87
10.6.2	Velocity, pressure and temperature.....	87
10.7	Expansion of heated water.....	87
10.8	Air elimination.....	87
10.8.1	General.....	87
10.8.2	Air elimination valves.....	87

10.9	Location of circulatory piping.....	88
10.9.1	General.....	88
10.9.2	Branch off-takes.....	88
10.9.3	Branch off-take with meter.....	88
10.9.4	Proximity to cold water piping.....	89
10.10	Isolating valves.....	89
10.10.1	General.....	89
10.10.2	Location.....	89
10.10.3	Multiple apartments, dwellings and secure areas.....	89
10.11	Balancing valves.....	90
10.11.1	General.....	90
10.11.2	Commissioning.....	90
<b>Appendix A (informative) Water analysis.....</b>		<b>91</b>
<b>Appendix B (informative) Demonstrating products and materials are fit for purpose.....</b>		<b>92</b>
<b>Appendix C (normative) Internal pipe diameters.....</b>		<b>94</b>
<b>Appendix D (informative) Preferred sizes of pipe for non-circulatory typical single-storey household installations.....</b>		<b>97</b>
<b>Appendix E (informative) Recommendations for the installation of unrated solar heated water supply systems.....</b>		<b>98</b>
<b>Appendix F (informative) Recommendations for the installation of close-coupled and integral solar heated water supply systems on roofs.....</b>		<b>100</b>
<b>Appendix G (informative) Solar heated water supply systems — Suggested component sizes (custom-built systems).....</b>		<b>103</b>
<b>Appendix H (informative) Estimation of shading of collectors.....</b>		<b>108</b>
<b>Appendix I (informative) Effect of inclination and orientation on system performance.....</b>		<b>113</b>
<b>Appendix J (informative) Map of regional basic design wind speeds.....</b>		<b>120</b>
<b>Appendix K (normative) Australian climate regions.....</b>		<b>122</b>
<b>Appendix L (normative) New Zealand climate regions.....</b>		<b>123</b>
<b>Appendix M (informative) Operation and maintenance.....</b>		<b>126</b>
<b>Appendix N (normative) Provision for expansion and contraction.....</b>		<b>127</b>
<b>Appendix O (informative) Estimation of probable simultaneous demand for residential buildings from the total of loading units.....</b>		<b>135</b>
<b>Appendix P (normative) Sizing of expansion vessels in mains pressure systems.....</b>		<b>136</b>
<b>Appendix Q (informative) Sizing of branches from circulatory heated water systems.....</b>		<b>139</b>
<b>Bibliography.....</b>		<b>141</b>

# Australian/New Zealand Standard

## Plumbing and drainage

### Part 4: Heated water services

#### Section 1 Scope and general

##### 1.1 Scope

This document sets out the requirements for the design, installation and commissioning of heated water services using drinking water or rainwater or a combination thereof. It includes aspects of the installation from, and including, the valve(s) on the cold water inlet to any cold water storage tank or water heater and the downstream fixtures and fittings. It applies to new installations as well as alterations, additions and repairs to existing installations.

This document applies to the installation of the following types of water heaters:

- (a) Storage water heaters with a rated delivery or capacity of up to 700 L per heater.
- (b) Heat exchange water heaters.

NOTE 1 Electric heat exchange water heaters are defined in AS 1361. Other fuel sources are covered in the applicable Standards, e.g. AS/NZS 2712, AS/NZS 5263.1.2.

- (c) Instantaneous, continuous flow water heaters.

NOTE 2 [Appendix M](#) provides guidelines for the operation and maintenance of heated water services.

Illustrations used in this Standard are diagrammatic only and have been chosen without prejudice.

##### 1.2 Application

###### 1.2.1 Australia

This document shall be read in conjunction with the relevant mandatory requirements for heated water services under the National Construction Code (NCC), primarily Volume Three, Plumbing Code of Australia (PCA).

Where alternative Australian or New Zealand Standards are referenced (e.g. AS 1345), the Australian Standard shall be used for Australia only.

###### 1.2.2 New Zealand

This document shall be read in conjunction with the New Zealand Building Code. This document may be used to demonstrate compliance with the New Zealand Building Code, Clause G12 Water Supplies.

Where alternative New Zealand Standards are referenced (e.g. NZS 5807), the New Zealand Standard shall be used for New Zealand only.

##### 1.3 Normative references

The following documents are referred to in the text in such a way that some or all of their content constitutes requirements of this document.

NOTE Documents referenced for informative purposes are listed in the Bibliography.

AS 1432, *Copper tubes for plumbing, gasfitting and drainage applications*

AS 3498, *Authorization requirements for plumbing products—Water heaters and hot-water storage tanks*

AS 4809, *Copper pipe and fittings — Installation and commissioning*

AS/NZS 2032, *Installation of PVC pipe systems*

AS/NZS 2642.2, *Polybutylene (PB) plumbing pipe systems, Part 2: Polybutylene (PB) pipe for hot and cold water applications*

AS/NZS 3500.0, *Plumbing and drainage, Part 0: Glossary*

AS/NZS 3500.1, *Plumbing and drainage, Part 1: Water services*

AS/NZS 4234, *Heated water systems — Calculation of energy consumption*

NZS 3501, *Specification of copper tubes for water, gas and sanitation*

NZS 4603, *Installation of low pressure thermal storage electric water heaters with copper cylinders (open-vented systems)*

NZS 4607, *Installation of thermal storage electric water heaters: valve-vented systems*

NZS 4219 *Seismic performance of engineering systems in buildings*

EN 10312, *Welded stainless steel tubes for the conveyance of aqueous liquids including water for human consumption — Technical delivery conditions*

ASME B36.19M, *Stainless Steel Pipe*

New Zealand Building Code, *Acceptable Solution H1/AS1: Energy Efficiency*

## 1.4 Terms and definitions

For the purpose of this document, the terms and definitions given in AS/NZS 3500.0 apply.

## 1.5 Plastics abbreviations

The following plastics abbreviations are used in this document:

ABS	Acrylonitrile butadiene styrene
GRP	Glass-filament-reinforced thermosetting plastic
PB	Polybutylene
PE	Polyethylene
PE-X	Cross-linked polyethylene
PP	Polypropylene
PP-R	Polypropylene random copolymer
PVC-C	Chlorinated polyvinyl chloride
PVC-M	Modified polyvinyl chloride
PVC-O	Oriented polyvinyl chloride
PVC-U	Unplasticized polyvinyl chloride

## 1.6 Water chemistry

Water chemistry can have a significant effect on the performance and life of water heaters and other items forming part of, or connected to, the heated water system.

**C1.6** Information on chemistry of the reticulated water should be available from the network utility operator. Where there is doubt about the suitability of a product for connection to the available water supply, advice about suitability should be sought from the manufacturer. The manufacturer may request a water sample or analysis, which should be in accordance with [Appendix A](#).

Where rainwater is used in heated water systems, it is particularly important that consumers are made aware of the advice from enHealth (Environmental Health Committee, “Guidance on use of rainwater tanks”) and manufacturers of items forming part of, or connected to, the heated water system.

## 1.7 Pipe sizes

Sizing based on internal diameter shall be as specified in [Appendix C](#).

Where the nominal size of a pipe or fitting is specified in this document, an equivalent pipe size appropriate to the material being used shall be selected from [Tables 1.7\(A\)](#) and [1.7\(B\)](#).

**Table 1.7(A) — Pipe size conversion for non-circulatory system**

Specified nominal size DN	Acceptable equivalent size						
	Copper		Stainless steel	PE-X	PB	PP-R	PE-X/AL/PE-X PE-X/AL/PE
	AS 1432	NZS 3501					
10	10	10	10	12	16 (15) <sup>a</sup>	12	10
15	15	15	15	16	16 (18)	16	15
18	18	—	18	20	20 (22)	20	20
20	20	20	20	25	25 (22)	25	20
25	25	25	25	32	32 (28)	32	25
32	32	32	32	40	40	40	32
40	40	40	40	50	50	50	50
50	50	50	50	63	63	63	63

<sup>a</sup> Sizes in brackets are for pipe in accordance with AS/NZS 2642.2.

**Table 1.7(B) — Pipe size conversion for circulatory flow systems inclusive of allowable hot water velocity differentials**

Specified nominal size DN	Acceptable equivalent size						
	Copper		Stainless steel	PE-X	PB	PP-R	PE-X/AL/PE-X PE-X/AL/PE
	AS 1432	NZS 3501					
15	15	15	15	16	16 (15) <sup>a</sup>	16	15
18	18	—	15	16	16 (18)	16	15
20	20	20	18	20	20 (22)	20	20
25	25	25	20	25	25 (22)	25	25
32	32	32	25	32	32 (28)	32	32
40	40	40	32	40	40	40	40
50	50	50	40	50	50	50	50
65	65	65	50	63	63	63	
80	80	80	65	75	75	75	

**Table 1.7(B)** (continued)

Specified nominal size DN	Acceptable equivalent size						
	Copper		Stainless steel	PE-X	PB	PP-R	PE-X/AL/PE-X PE-X/AL/PE
	AS 1432	NZS 3501					
90	90	90	80	90	90	90	
100	100	100	90	110	110	110	
125	125	125	100	125	125	140	
150	150	150	125	160	140	160	

<sup>a</sup> Sizes in brackets are for pipe in accordance with AS/NZS 2642.2.

NOTE 1 The acceptable equivalent sizes are determined from internal pipe diameters and the maximum water velocity requirements of [Clause 1.8](#) as applicable to each pipe material such that delivery rates are not less than the copper equivalent. This table is based on pipe diameters only.

NOTE 2 This table is based on pipe conforming to [Clause 2.4.1](#) and on Type B copper pipes, Series 2 or Schedule 5S and 10S stainless steel, SDR 9 – PEX, SDR 11 – PB pipe and SDR 7,4 PP – R pipes.

## 1.8 Velocity requirements

The maximum water velocity in piping up to 65 °C shall be in accordance with [Table 1.8](#).

**Table 1.8 — Maximum allowable velocities**

Piping	Maximum velocities, m/s	
	Copper pipes	Other materials
Circulatory (flow)	1.2	2.0
Circulatory return line	1.0	1.0
Non-circulatory (flow)	3.0	3.0

NOTE 1 Circulatory piping means piping where there is forced circulation of heated water.

NOTE 2 Circulatory piping does not include — (a) systems where the circulatory flow only occurs in response to activation by a user; and (b) primary circulation in a solar water heater.

NOTE 3 In circulatory piping, the maximum flow velocity is derived from the sum of forced circulation and probable simultaneous demand flow in the relevant section of piping.

NOTE 4 Pipework should be designed for velocities lower than the maximum to allow for variations in flow.

## 1.9 Pressure requirements

### 1.9.1 Available pressure

Pipe sizing shall be based on the minimum available pressure at the outlet from the water heater.

### 1.9.2 Pressure at outlets

The minimum working pressure at the furthest or most disadvantaged fixture or outlet shall be not less than 50 kPa (5 m head), at the flow rate specified in [Table 10.3.2](#).

NOTE 1 Storage tanks or booster pumps in accordance with AS/NZS 3500.1 may be required to achieve the minimum pressure.

NOTE 2 Some fixtures may require more than 50 kPa supply pressure in order to function.

### 1.9.3 Pressure losses

Allowance shall be made for pressure losses through pipes, valves, fittings, meters and any other equipment present in the installation.

### 1.9.4 Pressure booster pumps

#### 1.9.4.1 General

Pressure booster pumps installed in the cold water service supplying a water heater shall be installed in accordance with AS/NZS 3500.1.

#### 1.9.4.2 Pump control

Pressure booster pumps shall be sized, installed and controlled so as to prevent repetitive pressure cycling or spiking.

Cyclic pressures within the heated water system shall not exceed a 25 kPa differential three times per minute when averaged over a 24 h period.

***C1.9.4.2** Cyclic pressures in heated water systems are damaging to both pipework and heated water tanks and equipment. Cyclic pressures can be caused by incorrectly sized backflow valves, pressure reduction valves and booster pumps, particularly when operating at low flow rates. Pressure variations within heated water systems are intensified when systems have trapped entrained air which can lead to cavitation damage.*

### 1.10 Flow rates

Flow rates and loading units shall be as specified in [Clause 10.3](#).

### 1.11 Water temperature

#### 1.11.1 General

In Australia, the requirements for heated water temperature control are specified in the Plumbing Code of Australia.

In New Zealand, the requirements for maximum heated water delivery temperatures and acceptable temperature control devices are specified in the NZBC Acceptable Solution G12/AS1.

#### 1.11.2 Storage temperature

To avoid the likelihood of legionella bacteria growth, an installation shall —

- (a) store water at a temperature not less than 60 °C; or
- (b) use a water heater that satisfies the requirements of AS 3498:2020 Clause 7.2 (Australia only).

## Section 2 Materials and products

### 2.1 Scope of section

This section specifies requirements for materials and products to be used in heated water services.

### 2.2 General

Materials and products used in a heated water service shall be selected to ensure fitness for their intended purpose.

NOTE 1 See [Appendix B](#) for more information.

In New Zealand, materials and products in contact with water that is intended for human consumption, food preparation, utensil washing, personal hygiene or oral hygiene shall conform to AS/NZS 4020. Linings and coatings shall conform to AS/NZS 4020 at a surface area to volume ratio not greater than that applicable to the installation.

NOTE 2 In New Zealand, the requirements for materials and products are contained in NZBC Clauses B2 Durability and G13 Foul Water.

NOTE 3 In Australia, the requirements for products in contact with drinking water are contained in the Plumbing Code of Australia.

### 2.3 Pipes and fittings — General limitations

The following limitations shall apply to the use of pipes and fittings for heated water services:

- (a) Pipes and fittings —
  - (i) up to and including DN 100, shall have a maximum allowable operating pressure of at least 1.0 MPa at 60 °C; and
  - (ii) larger than DN 100, shall be selected to accommodate the nominated operating pressure and temperature for the system.
- (b) Bends in pipes shall be free from wrinkling and flattening.
- (c) Semi-flexible connectors and braided flexible hoses shall only be used above surface level and in accessible locations.
- (d) Pipes and fittings shall be protected from excessive ambient heat.

NOTE 1 Limitations on the use of pipes and fittings should take into consideration the manufacturer's installation specifications, provided they do not contradict the requirements of this document.

- (e) Soft solder jointing shall not be used for new joints.

NOTE 2 For the repair of existing joints, soft solder should not contain more than 0.1 % lead by weight.

### 2.4 Metallic pipes and fittings

#### 2.4.1 Heated water services

Where metallic pipes and fittings are used in a heated water service, they shall be of the following material types:

- (a) Copper pipes and fittings.
- (b) Copper alloy fittings.

- (c) Stainless steel pipes and fittings.

NOTE See [Appendix B](#) for information on demonstrating products and materials are fit for purpose.

### 2.4.2 Limitations

Metallic pipes and fittings shall conform to the following:

- (a) Fittings used to join stainless steel (SS) pipes shall be dezincification resistant (DR) copper alloy or stainless steel.

NOTE 1 Refer to AS 3688 for information on metallic fittings and end connectors.

- (b) For corrosion resistance, the composition of stainless-steel pipes, tubes and fittings shall have a minimum pitting resistance equivalent number (PREN) of 22.

NOTE 2 The PREN may be calculated as follows:

$$\text{PREN} = \% \text{Cr} + (3.3 \times \% \text{Mo}) + (16 \times \% \text{N})$$

NOTE 3 A PREN of 18 is approximately equivalent to Grade 304, and a PREN of 23 is approximately equivalent to Grade 316.

- (c) Copper pipe shall only be of Type A, B or C.

NOTE 4 Copper pipes manufactured in accordance with NZS 3501 are also suitable for use in New Zealand.

NOTE 5 Refer to AS 1432 for information on copper types (A, B or C).

NOTE 6 Refer to AS 3688 for information on metallic fittings and end connectors.

## 2.5 Plastics pipes and fittings

### 2.5.1 Heated water services

Where plastic pipes and fittings are used in a heated water service, they shall be of the following material types:

- (a) Polybutylene (PB) pipes and fittings.
- (b) Cross-linked polyethylene (PE-X) pipes and fittings.
- (c) Polypropylene random copolymer (PP-R) pipes and fittings.
- (d) Multilayer pipes (MLP) and fittings.
- (e) Chlorinated polyvinyl chloride (PVC-C) pipes and fittings.

NOTE 1 See [Appendix B](#) for information on demonstrating products and materials are fit for purpose.

NOTE 2 The following Standards contain additional information:

- (a) AS/NZS 2642.2 or AS 5082.1 — hot and cold. water polybutylene (PB) pipes
- (b) AS/NZS 2642.3 or AS 5082.2— mechanical jointing fittings for use in PB piping systems.
- (c) AS/NZS 2492 — cross-linked polyethylene (PE-X) pipes
- (d) AS/NZS 2537 (parts 1, 2 and 5) — mechanical jointing fittings for use with crosslinked polyethylene (PE-X) pipes.
- (e) ISO 15874-2 — polypropylene random copolymer (PP-R) pipes and ISO 15874-3. — fittings for PP-R pipes

- (f) AS 4176 (parts 1, 2, 3, 5 and 7) — multilayer pipes (MLP) and fittings for pressure applications.
- (g) ASTM D2846 — chlorinated polyvinyl chloride (PVC-C) fittings

### 2.5.2 Limitations

Plastics pipes and fittings shall conform to the following:

- (a) When installed, plastics pipes and fittings shall be protected from direct sunlight.  
NOTE 1 Examples of protection include sleeving with metal or plastics pipe or conduit, lagging.
- (b) Plastics pipes and fittings shall not be used between the isolation valve and the inlet to a water heater.
- (c) Plastics pipes and fittings shall not be used within 1 m of the outlet of a water heater.  
NOTE 2 Plastics pipes and fittings may be used immediately downstream of a temperature control device or a 50 °C temperature-limited water heater.
- (d) Plastics pipes shall not be used to support isolation valves, non-return valves and equipment used to connect water heaters.
- (e) Plastics pipes and fittings shall not be used between solar collectors and heated water containers, unless supplied as an integral component of the solar water heater system.
- (f) Plastics pipes and fittings shall not be used between an uncontrolled heat source and a heated water tank.
- (g) Plastics pipes and fittings shall not be used for the drain lines from temperature/pressure-relief valves.

NOTE 3 It is recommended that the minimum pressure rating for plastic pipes used in a heated water service is PN 16. For further information refer to AS/NZS 2492.

## 2.6 Safe tray and safe waste materials

### 2.6.1 Safe tray

Safe trays shall be fabricated from —

- (a) 0.6 mm thick galvanized steel sheet with a minimum nominal zinc coating mass of 275 g/m<sup>2</sup>; or
- (b) other materials not inferior to Item (a), under the conditions of use.

NOTE Refer to AS 1397 for information on continuous hot-dip metallic coated steel sheet and strip coatings of zinc and alloyed with aluminium and magnesium.

### 2.6.2 Safe wastes

Safe waste pipes from safe trays shall be fabricated from the following materials:

- (a) PVC-U.
- (b) Galvanized steel pipe.
- (c) Seamless copper pipe (minimum thickness of 0.9 mm).
- (d) Sheet steel (minimum thickness of 0.6 mm) with a minimum nominal zinc coating mass of 275 g/m<sup>2</sup>.

## 2.7 Joints

### 2.7.1 Flanged joints

Where flanged joints are used, they shall be of the following material types:

- (a) Ductile iron, cast iron and grey cast iron.
- (b) Copper alloy and composite.
- (c) Steel.

NOTE The following Standards contain additional information:

- (a) AS 2129 — flanges for metal pipes, valves and fittings.
- (b) AS/NZS 4331.1 — steel flanges.
- (c) AS/NZS 4331.2 — cast iron flanges.
- (d) AS/NZS 4331.3 — copper and copper alloy composite flanges.
- (e) AS/NZS 4087 — metallic flanges for waterworks purposes.
- (f) AS/NZS 1477 — PVC pipes and fittings for pressure applications.
- (g) AS/NZS 2280 — ductile iron pipes and fittings.
- (h) AS/NZS 2544 — grey iron pressure fittings.

### 2.7.2 Elastomeric seals

Where an elastomeric seal gasket is provided in the line or in a fitting, it shall not be replaced with mastic or sealant compounds.

NOTE Refer to AS 1646 for information on elastomeric seals for waterworks purposes.

### 2.7.3 Silver brazing alloy

#### 2.7.3.1 Copper and copper alloys

Silver brazing alloys for capillary jointing of copper and copper alloy pipes and fittings shall conform to the requirements for silver or copper phosphorus brazing alloys and contain a minimum of 1.8 % silver and a maximum of 0.05 % cadmium.

NOTE Refer to AS/NZS 1167.1 for information on filler metal for brazing and braze welding.

#### 2.7.3.2 Stainless steel

Silver brazing alloys for capillary jointing of stainless steel pipes and fittings shall contain a minimum of 38 % silver and a maximum of 0.05 % cadmium.

NOTE Refer to AS/NZS 1167.1 for information on filler metal for brazing and braze welding.

### 2.7.4 Filler rods for stainless steel joints

Welded joints in stainless steel pipework larger than DN 25 shall be made using filler rods of low carbon stainless steel not greater than 2 mm in diameter.

NOTE Refer to AS/NZS 1167.2 for information on welding for brazing, filler metal for welding.

## 2.8 Miscellaneous materials

### 2.8.1 Concrete mix

Ready-mixed concrete shall have a minimum characteristic compressive strength of 20 MPa.

Site-mixed concrete shall consist of cement, fine aggregate and coarse aggregate, all measured by volume, properly mixed with water sufficient to render the mix workable. It shall have a minimum characteristic compressive strength of 20 MPa.

NOTE 1 Refer to AS 1379 for information on the specification and supply of concrete.

NOTE 2 The compressive strength of concrete is defined in —

- (a) AS 3600 for Australia; and
- (b) NZS 3109 and NZS 3124 for New Zealand.

NOTE 3 Refer to AS/NZS 4671 for information for steel reinforcing materials.

### 2.8.2 Cement mortar

Cement mortar shall consist of one part cement and two parts of fine aggregate measured by volume, properly mixed with the minimum amount of water necessary to render the mix workable.

NOTE 1 For bedding pipes, a mixture consisting of one part cement to four parts fine aggregate may be used.

Cement mortar that has been mixed and left standing for more than 1 h shall not be used.

NOTE 2 Refer to AS 1478.1 for information on chemical admixtures for concrete, mortar and grout.

### 2.8.3 Water for concrete and mortar

Water used for mixing concrete and cement mortar shall be free from impurities that are harmful to the mixture, the reinforcement, or any other items embedded within the concrete or mortar.

### 2.8.4 Timber

#### 2.8.4.1 Timber in Australia

In Australia, timber exposed to the weather shall be of durability Class 2 or treated with an appropriate preservative. Timber in contact with the ground shall be of durability Class 1.

NOTE 1 Refer to AS/NZS 2878 for information on timber classification into strength groups.

NOTE 2 Refer to the AS/NZS 1604 series for information on preservative treatment of sawn and round timber.

#### 2.8.4.2 Timber in New Zealand

In New Zealand, timber exposed to the weather shall be treated to H3 (CCA). Timber in contact with the ground shall be treated to H4 (CCA).

NOTE 1 Refer to NZS 3631 for information on timber grading rules.

NOTE 2 Refer to NZS 3640 for information on chemical preservation of round and sawn timber.

### 2.8.5 External protective coatings

External coatings used for protection against corrosion of pipelines buried in corrosive areas shall —

- (a) be impervious to the passage of moisture;

- (b) be resistant to the external corrosive environment;
- (c) be resistant to abrasion by the surrounding fill; and
- (d) not contain any material that could cause corrosion to the underlying pipes or fittings.

NOTE Polyethylene sleeving used to protect underground pipelines may require additional protection if installed in rock or stony ground.

## Section 3 Cross-connection and backflow prevention and thermostatic mixing valves

### 3.1 Scope of section

This section sets out the requirements for the installation of backflow prevention devices and thermostatic mixing valves.

### 3.2 Cross-connection control and backflow prevention

Cross-connection controls and backflow prevention devices shall be installed in accordance with AS/NZS 3500.1.

### 3.3 Thermostatic mixing valves

The following apply to the installation of thermostatic mixing valves:

- (a) Each thermostatic mixing valve shall have an isolating stop tap/valve, line strainer and cross-flow prevention device (non-return) valve fitted to the heated and cold water supply lines.

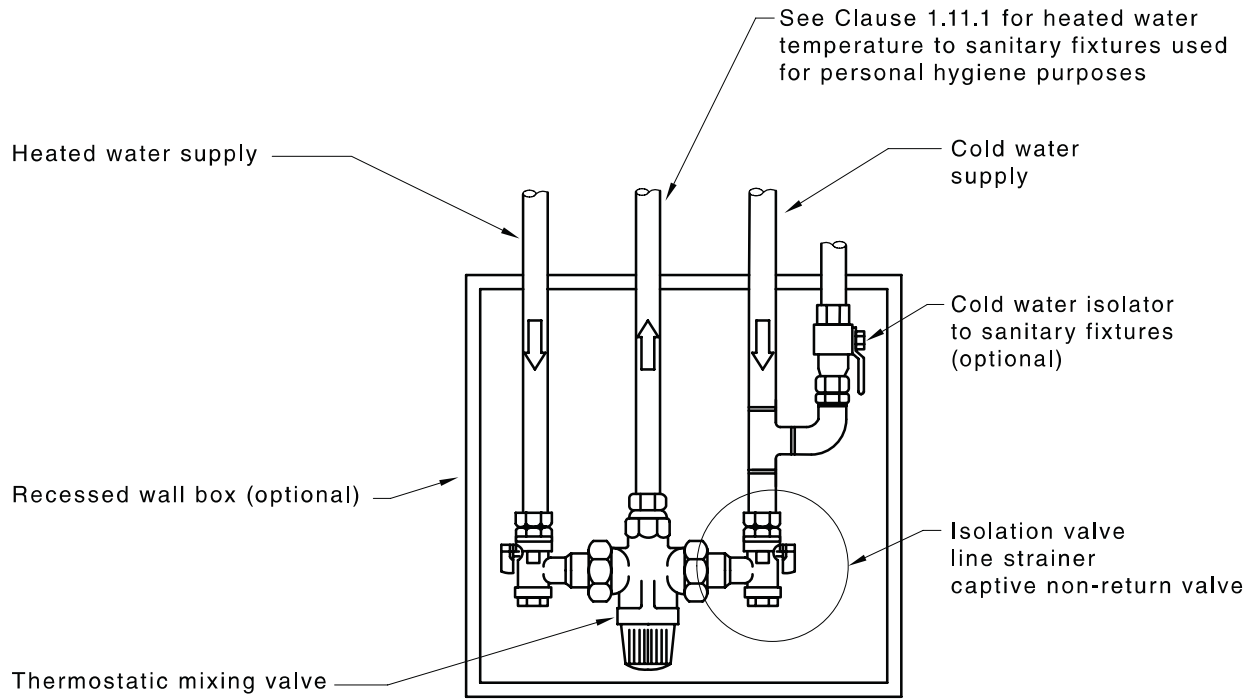
NOTE 1 These devices may be fitted separately from the thermostatic mixing valve or as an integral part of the valve.

NOTE 2 See [Figure 3.3](#) for a typical installation of a thermostatic mixing valve.

NOTE 3 Refer to AS 4032.1 for information on metallic-bodied thermostatic mixing valves.

- (b) There shall be no branch line off-take between a non-integral isolating valve and the inlet to the thermostatic mixing valve except in multiple installations, see Item (d).
- (c) Thermostatic mixing valves shall be supported independent of all piping.
- (d) Where multiple installations of thermostatic mixing valves are located in the same area, a stop tap/valve, line strainer and non-return valve may control each of the hot and cold water supplies to more than one thermostatic mixing valve, provided each of the individual thermostatic mixing valves is controlled by an isolating stop tap/valve and installed with a cross-flow non-return valve.
- (e) Each thermostatic mixing valve and each associated valve, pressure control or temperature control shall be readily accessible.
- (f) The nominal size of the connecting piping and associated valves shall be not less than the nominal size of the thermostatic mixing valve.
- NOTE 4 Refer to AS/NZS 3500.1 for sizing of pipes.
- (g) The flushing specified in [Clause 9.2](#) shall be undertaken —
- (i) prior to the installation of the thermostatic mixing valve(s); or
  - (ii) after the installation of the thermostatic mixing valve(s), provided each line-strainer integral and non-integral isolating valve and each thermostatic element/sensor is removed and cleaned and replaced after the flushing operation is completed.

NOTE 5 See [Clauses 9.3](#) and [9.4](#) for testing and commissioning requirements.



**Figure 3.3 — Typical installation of thermostatic mixing valve**

## Section 4 Installation of cold and heated water piping and controls

### 4.1 Scope of section

This section sets out requirements for the installation of pipes, fittings, cold water storage tanks and apparatus used to supply water to and from a water heater.

***CA.1** Safety precautions need to be observed when cutting into pipework or disconnecting water meters, fittings and devices on pipework. There have been fatalities and injuries that have been attributed to water services carrying an electrical current.*

*Where existing metallic service pipework is to be replaced in part or in its entirety by plastics pipe or other non-metallic fittings or couplings, the work should not commence until the earthing requirements have been checked by an electrical contractor and modified, if necessary.*

### 4.2 Installation of pipes and fittings

Copper pipes and fittings shall be installed in accordance with AS 4809.

### 4.3 Proximity to other services

#### 4.3.1 General

Where electrical conduits, wires, cables or consumer gas pipes, drains and other services are in existence, pipes shall be installed in accordance with [Clause 4.3.2](#).

#### 4.3.2 Electrical cables, gas pipes and other services

##### 4.3.2.1 General

Both above- and below-ground pipework associated with heated water services shall be installed so that —

- (a) no potential safety hazard is created when in close proximity to other services; and
- (b) access for maintenance and potential branch insertions is not impaired by other services.

##### 4.3.2.2 Above-ground services

Separation of at least 25 mm shall be maintained between any above-ground water service and any of the following services:

- (a) Electrical or telecommunications conduits.
- (b) Electrical or telecommunications wires or cables.
- (c) Consumer gas pipes.
- (d) Sanitary plumbing and drainage.
- (e) Storm water drainage.
- (f) Other above-ground water services.
- (g) Any other services.

Where a pipe is insulated, the measurement shall be from the outer edge of any insulation or wrapped material applied to the pipework.

#### 4.3.2.3 Below ground — Electrical cables and gas pipes

Below ground, the separation between pipework associated with heated water services and electrical cables and gas pipes shall be —

- (a) not less than 300 mm; or
- (b) not less than 100 mm, provided the electrical cables or gas pipes are marked and mechanically protected along their length within the exclusion zone.

NOTE Mechanical protection may be provided by concrete slabs, continuous concrete pour, polymeric cover strips, or bricks designed for protecting electrical supply cables and may include a suitable conduit.

#### 4.3.2.4 Below ground — Communications

Below ground, the separation between pipework associated with heated water services and communication services shall be maintained at 100 mm.

#### 4.3.3 Crossover of underground services

Below ground, any crossover of pipework associated with heated water service shall —

- (a) cross at an angle of not less than 45°;
- (b) have a vertical separation of not less than 100 mm; and
- (c) be marked and mechanically protected.

### 4.4 Methods of jointing

#### 4.4.1 General

Jointing of pipework associated with heated water services shall be in accordance with the following:

- (a) *Removal of burr* — The burr formed in cutting any pipe shall be removed.
- (b) *Joints requiring use of heat* — Pipes or fittings shall not be damaged by the application of excessive heat.
- (c) *Use of fittings* — Where straight sections of pipe of different diameter are to be joined, such increase or reduction in size shall be made by a fitting.
- (d) *Crimping* — Crimping shall not be used to reduce pipe diameter when jointing.
- (e) *Jointing of copper or stainless steel pipes* — Copper or stainless steel water service pipes of different diameter shall not be joined by filling the annular space using a filler rod.

NOTE 1 AS 3688 specifies the types of metallic joints and end connectors.

- (f) *Fabricated fittings* — Where sockets and tees are fabricated from copper, copper alloy or stainless steel pipes:
  - (i) They shall be made using tools designed for such purposes.
  - (ii) They shall be jointed by silver brazing.
  - (iii) Copper tees shall not be fabricated from pipe of thickness less than Type C.

NOTE 2 In Australia, AS 1432 provides information on copper types.

NOTE 3 In New Zealand, copper tube conforming to NZS 3501 may also be used.

#### 4.4.2 Compression joints

Plastics nuts shall not be used to connect any pipe to a cold water storage tank that supplies water to a water heater.

NOTE For further information on compression fittings, refer to AS 3688 and AS/NZS 4129.

#### 4.4.3 Silver brazing

##### 4.4.3.1 Joints

A compatible flux shall be used when making joints using silver brazing.

##### 4.4.3.2 Taps and valves

Silver brazing shall not be used as a means of jointing taps or valves to pipes larger than DN 20. To prevent damage, the tap assembly and jumper valve shall be removed from the body of taps and valves prior to silver brazing.

#### 4.4.4 Flanged joints

Flanged joints shall be appropriate for the test pressure requirements of [Section 9](#). Flanged joints shall be attached to the pipe by the following means:

- (a) Silver brazing in accordance with [Clause 2.7.3](#) for copper alloy to copper or copper alloy pipes or fittings.
- (b) Set screws for cast iron pipes and fittings.

Flange joints below ground shall be protected against corrosion in accordance with [Clause 4.9](#).

NOTE Refer to AS 2129 for information on flanges for pipes, valves and fittings.

#### 4.4.5 Roll-grooved joints

Where used below ground, roll-grooved joints shall be —

- (a) protected against corrosion with each assembled copper joint protected with a petrolatum-based wrapping system; and
- (b) external to a building and not under concrete.

NOTE Refer to AS 3688 for information on metallic fittings and end connectors.

#### 4.4.6 Jointing of copper and copper alloy pipes

Fittings used to join copper and copper alloy pipes shall be installed in accordance with the installation requirements of AS 4809.

NOTE Fittings used for copper and copper alloys include capillary, press-fit, push-fit, roll-grooved, compression and threaded end connectors.

#### 4.4.7 Jointing of stainless-steel pipe and fittings

##### 4.4.7.1 Jointing of piping up to and including DN 25

Joints not larger than DN 25 shall be made by using either mechanically jointed compression fittings, press-fit end connectors or silver-brazed stainless steel capillary joints.

NOTE Refer to AS 3688 for information on metallic fittings and end connectors.

#### 4.4.7.2 Jointing of piping larger than DN 25

Joints in stainless steel piping larger than DN 25 shall be one of the following:

- (a) Butt-welded using a tungsten inert gas (TIG) argon arc method and —
  - (i) have a gap not greater than 0.5 mm between the abutting pipe ends to be joined;
  - (ii) have inserted a back-up ring 6 mm long, made from the parent pipe, to straddle the joint of pipes with a wall thickness less than 1.2 mm;
  - (iii) use a low carbon stainless steel type filler rod not greater than 2 mm in diameter; and
  - (iv) be tack-welded in not less than four spots around the circumference, prior to welding the entire joint.
- (b) Flanged joints, using a stub flange, fabricated by rolling or welding to the pipe. The stub flange shall have —
  - (i) the same wall thickness as the pipe;
  - (ii) a diameter equal to the outside diameter (OD) of the mating part or have a mild steel backup flange fitted; and
  - (iii) a gasket not less than 3 mm thick inserted.
- (c) Stainless steel press-fit end connectors.

NOTE 1 Refer to AS 2129 for information on flanges for pipes, valves and fittings.

NOTE 2 Refer to AS/NZS 4331.1 for information on steel flanges.

NOTE 3 Refer to AS/NSS 4331.2 for information on cast iron flanges.

NOTE 4 Refer to AS/NZS 4331.3 for information on copper alloy and composite flanges.

NOTE 5 Refer to ASTM A182/A182M for information on forged or rolled alloy and stainless-steel pipe flanges.

#### 4.4.8 Jointing of plastics pipes

##### 4.4.8.1 PVC-C

Jointing of pipes and fittings of PVC-C material shall be carried out in accordance with AS/NZS 2032.

##### 4.4.8.2 Other plastics pipes

Jointing of PB pipes shall be carried out using fittings that are compatible with PB pipes.

NOTE 1 The following Standards contain additional information:

- (a) AS/NZS 2642.3 — mechanical jointing fittings for use with hot and cold water polybutylene piping systems.
- (b) AS 5082.2 — mechanical and fusion jointing of polybutylene piping systems.

Jointing of PE-X pipes shall be carried out using fittings that are compatible with PE-X pipes.

NOTE 2 Refer to the AS/NZS 2537 series for information on mechanical jointing fittings for use with crosslinked polyethylene for pressure applications.

Jointing of MLP pipes shall be carried out using fittings that are compatible with MLP pipes.

NOTE 3 Refer to the AS 4176 series for information on multilayer pipes for pressure applications.

Jointing of PP-R pipes shall be carried out using fittings that are compatible with PP-R pipes.

NOTE 4 Refer to ISO 15874-3 for information on plastic piping systems for hot and cold water installations including appropriate PP-R fittings.

## 4.5 Support and fixing above ground

### 4.5.1 General

Water services installed above ground shall be retained in position by brackets, clips or hangers.

### 4.5.2 Brackets, clips and hangers

Brackets, clips and hangers shall be —

- (a) formed from a material compatible with the pipe;
- (b) securely attached to the building structure;
- (c) designed to withstand the applied loads;
- (d) protected against corrosion where exposed to a corrosive environment;
- (e) of like material or lined with a non-abrasive, inert material for that section where contact with the piping may occur;
- (f) clamped securely to prevent movement, unless designed to allow for thermal movement;
- (g) restrained to prevent lateral movement; and
- (h) installed so that no movement can occur while a valve is being operated and that the weight of the valve is not transferred to the pipe.

### 4.5.3 Limitations on pipe supports

The following methods of support shall not be used:

- (a) Pipes supported by brazing or welding short sections of any material to the pipe surface or by clamping, brazing or welding to adjacent pipes.
- (b) Brackets, clips and hangers incorporating PVC used in contact with stainless steel pipes.

### 4.5.4 Spacing

Water services shall be supported and fixed at the intervals specified in [Table 4.5.4](#).

**Table 4.5.4 — Spacing of brackets and clips**

Nominal pipe size DN	Maximum spacing of brackets and clips, m		
	Copper, copper alloy and stainless steel pipes	PE-X, PB, PVC-C and PP-R PE/AL/PE PE-X/AL/PE-X pipes	
		Horizontal or graded pipes	Vertical pipes
10	1.5	0.5	1
15	1.5	0.6	1.2
16	—	0.6	1.2
18	1.5	0.6	1.2
20	1.5	0.7	1.4
22	—	0.7	1.4

Table 4.5.4 (continued)

Nominal pipe size DN	Maximum spacing of brackets and clips, m		
	Copper, copper alloy and stainless steel pipes	PE-X, PB, PVC-C and PP-R PE/AL/PE PE-X/AL/PE-X pipes	
		Horizontal or graded pipes	Vertical pipes
25	2	0.75	1.5
32	2.5	0.85	1.7
40	2.5	0.9	1.8
50	3	1.05	2.1
63	—	1.1	2.2
65	3	1.2	2.4
75	—	1.3	2.6
80	3	1.35	2.7
90	3	1.4	2.8
100	3	1.5	3
110	—	1.5	3
125	3	1.7	3.4
140	—	1.7	3.4
150	3	2	4
160	—	2	4
200	3	2	4

NOTE Due to water pressure effects, additional brackets, clips or hangers (conforming to [Clause 4.5.2](#)) may be required to prevent movement.

#### 4.5.5 Securing of pipes and fittings

Any pipe or fitting that may be subjected to strain or torsion shall be positively fastened against twisting or any other movement.

For heated water piping, the fixing shall be in such a manner as to allow movement due to thermal expansion and not to cause damage or corrosion to the pipe.

NOTE See [Clause 4.5.3\(b\)](#).

### 4.6 Location of piping

#### 4.6.1 Concealed piping

##### 4.6.1.1 Walls

Water services located in timber- or metal-framed walls shall be installed in accordance with the following:

- (a) *Timber wall framework* — Holes or notches made in timber studs and plates in walls shall be in accordance with the following:
  - (i) The maximum size and spacing of holes or notches in studs shall be in accordance with [Figure 4.6.1.1\(A\)](#) and [Table 4.6.1.1](#).
  - (ii) Where unlagged pipes are used, a collar of lagging material or a neutral cure silicone sealant shall be used to fill the annular space.
- (b) *Timber beams, bearers and joists* — Holes or notches made in timber beams, bearers and joists in floors shall be in accordance with [Figure 4.6.1.1\(B\)](#).

- (c) *Metal wall framework* — Water services shall be installed in existing preformed holes where possible. Additional holes, where required, shall be no larger than the preformed holes installed by the manufacturer or 32 mm when there are no pre-existing holes. The additional holes shall be placed —
- (i) with hole centres no further from the centreline of the member than  $\pm 10\%$  of the member depth;
  - (ii) at a minimum spacing or end distance of 4 times the hole diameter (for single holes); and
  - (iii) at a minimum spacing or end distance of 8 times the hole diameter (for pair-to-pair or single-to-pair holes), see [Figure 4.6.1.1\(C\)](#).

If holes are less than 4 times the hole diameter apart, they are considered a pair.

NOTE 1 An engineered system may have more numerous or closely spaced holes depending on the design.

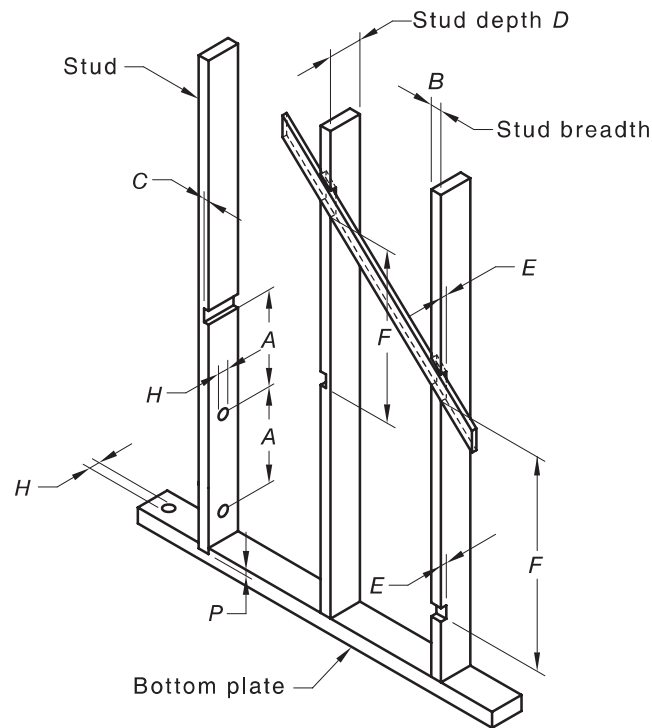
Holes may be plain (unflared) or flared. For plain holes, metal and polymer pipes shall be protected from contact with the hole edge. For flared holes, metal pipes shall be isolated from contact with the hole flare. Protection or isolation shall be provided using suitable grommets, insulation, or a short sleeve of oversize pipe firmly secured in the framework to be inserted around the pipe. There shall be no direct contact between the pipe and framework. There shall be free longitudinal movement of the pipe through the grommet, lagging or sleeve.

All pipes shall be secured in accordance with [Clause 4.5](#).

- (d) *Metal beams, bearers and joists* — Holes made in metal beams, bearers and joists shall be in accordance with [Figure 4.6.1.1\(D\)](#).

NOTE 2 Care should be taken to ensure that the air cavity moisture barrier within an external wall of any building is not bridged with pipe or pipe duct penetrations and porous pipe insulation materials. A clear air gap is required between the external wall and the pipe insulation material.

- (e) Pipes located in cavities shall be installed to prevent the transfer of moisture from the outer wall to the inner wall.



NOTE For definitions of symbols, see [Table 4.6.1.1](#).

**Figure 4.6.1.1(A) — Notching of wall studs**

**Table 4.6.1.1 — Holes and notches in studs and plates**

Symbol	Definition	Limits	
		Notched	Not notched
<i>A</i>	Distance between holes and/or notches in stud breadth	Minimum $3D$	Minimum $3D$
<i>H</i>	Hole diameter (studs and plates)	Maximum 25 mm (wide face only)	Maximum 25 mm (wide face only)
<i>C</i>	Notch into stud breadth	Maximum 10 mm	Maximum 10 mm
<i>E</i>	Notch into stud depth	Maximum 20 mm (for diagonal cut in bracing only) <sup>a</sup>	Not permitted <sup>a</sup>
<i>F</i>	Distance between notches in stud depth	Minimum $12B$	N/A
<i>P</i>	Trenches in plates	3 mm maximum	

<sup>a</sup> horizontal line of notches up to 25 mm may be provided for the installation of baths.

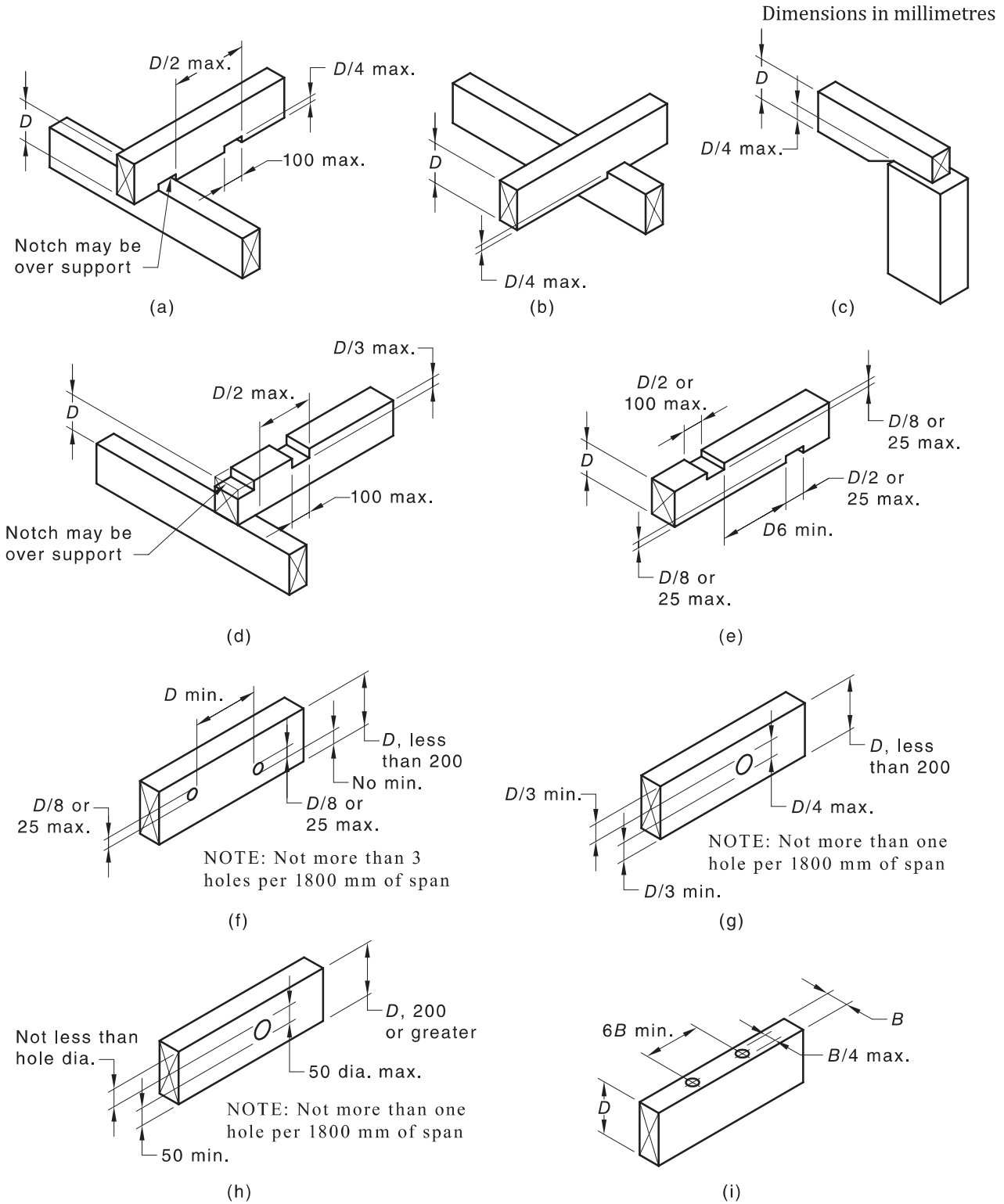


Figure 4.6.1.1(B) — Notches, cuts and holes in beams, bearers, joists, rafters

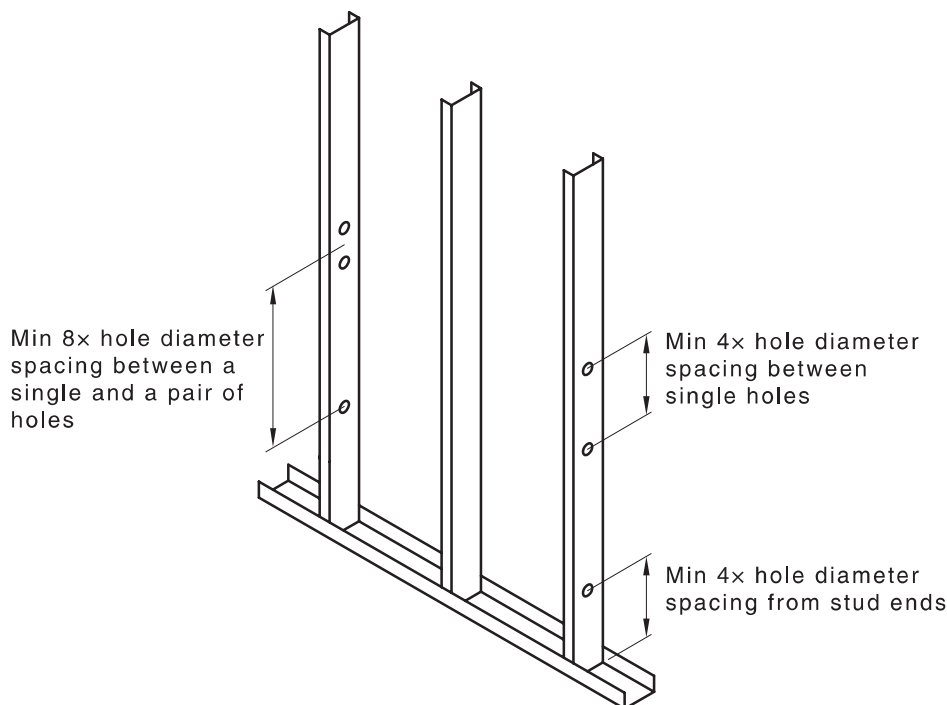
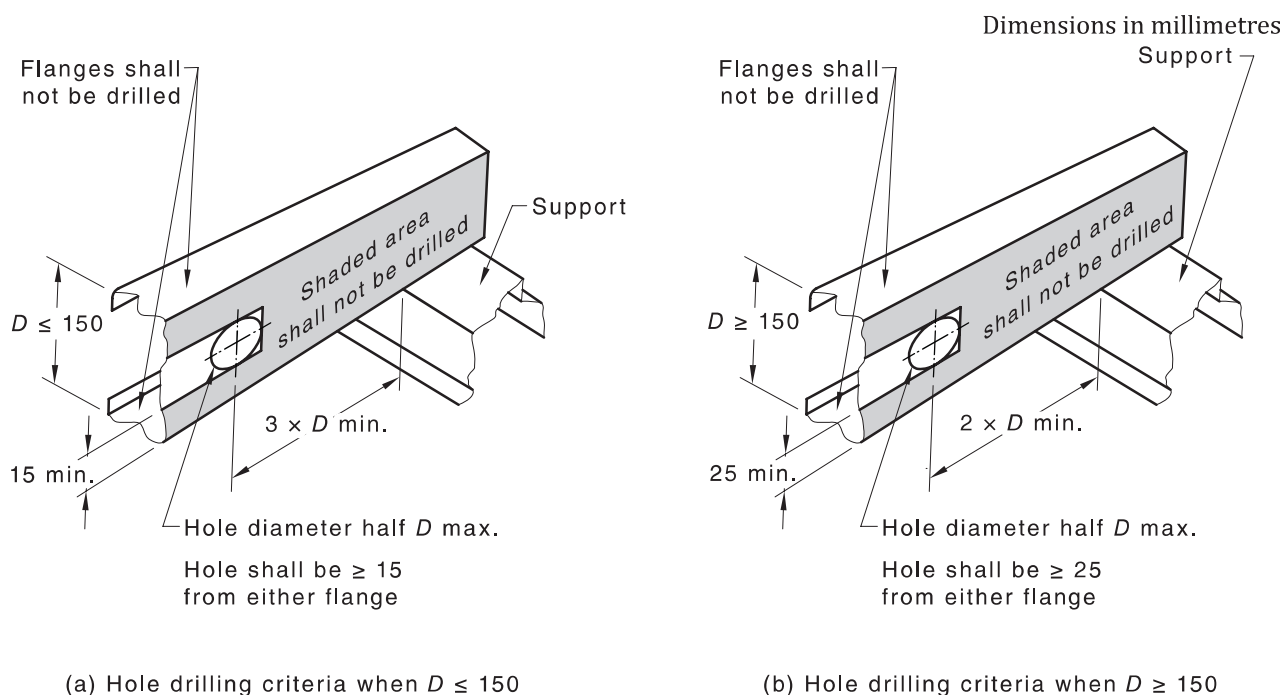


Figure 4.6.1.1(C) — Hole spacing in metal wall framework



(a) Hole drilling criteria when  $D \leq 150$

(b) Hole drilling criteria when  $D \geq 150$

Figure 4.6.1.1(D) — Penetrations to steel floor joist

4.6.1.2 Chases, ducts or conduits

Pipes located in chases, ducts, conduits or embedded in masonry or concrete shall be installed in accordance with the following:

- (a) Pipes and fittings in chases shall be continuously wrapped with an impermeable flexible material.

- (b) Ducts shall be fitted with removable covers.
- (c) Adequate allowance shall be made for expansion and contraction in accordance with [Clause 4.13.3](#).
- (d) Pipes shall not be embedded or cast into concrete structures.

#### 4.6.1.3 Under concrete slabs

Water service pipes located beneath concrete slabs on ground level shall conform to the following:

- (a) Pipes shall be insulated in accordance with [Clause 8.2](#), laid in a narrow trench on a bed of sand or fine-grained soil, placed and compacted in a manner that will not damage the piping or insulation. There shall be a minimum distance of 75 mm between the pipe and the underside of the slab.
- (b) Pipe ends shall be crimped or capped prior to pouring of the concrete. The exposed pipe shall be protected from damage.
- (c) Any piping that penetrates the slab shall be at right angles to the surface of the slab and be lagged with an impermeable, flexible plastic material not less than 6 mm thick for the full depth of the slab penetration.
- (d) Soft-soldered joints shall not be used.
- (e) The number of joints shall be kept to a minimum.

#### 4.6.2 Protection during building construction

Concealed pipework shall be maintained under normal water pressure during subsequent building operations. The service shall be flushed with clean water at regular intervals until the building is occupied.

NOTE Care should be taken to ensure that the pipes are not damaged during building activities.

#### 4.6.3 Floor or roof penetrations

Any suspended floor or roof penetration shall be rendered waterproof to allow for expansion.

#### 4.6.4 Provision for movement of encased piping

All heated water piping, including relief drain pipes, encased in plaster, mortar or similar material shall be wrapped to allow movement due to expansion and contraction.

### 4.7 Bedding and backfill

The water services shall be surrounded with not less than 75 mm of compacted sand, or fine-grained soil, with no hard-edged object in contact with or resting against any pipe or fitting.

NOTE See [Figure 4.7](#) for a typical installation in a trench.

Backfill shall be free from builder's waste, bricks, concrete pieces, rocks or hard matter larger than 25 mm and broken up so that it contains no soil lumps larger than 75 mm.

Copper and stainless steel pipelines may be installed in soil excavated from the trench in which it is to be installed, provided the soil is compatible with copper and stainless steel and free from rock and rubble.

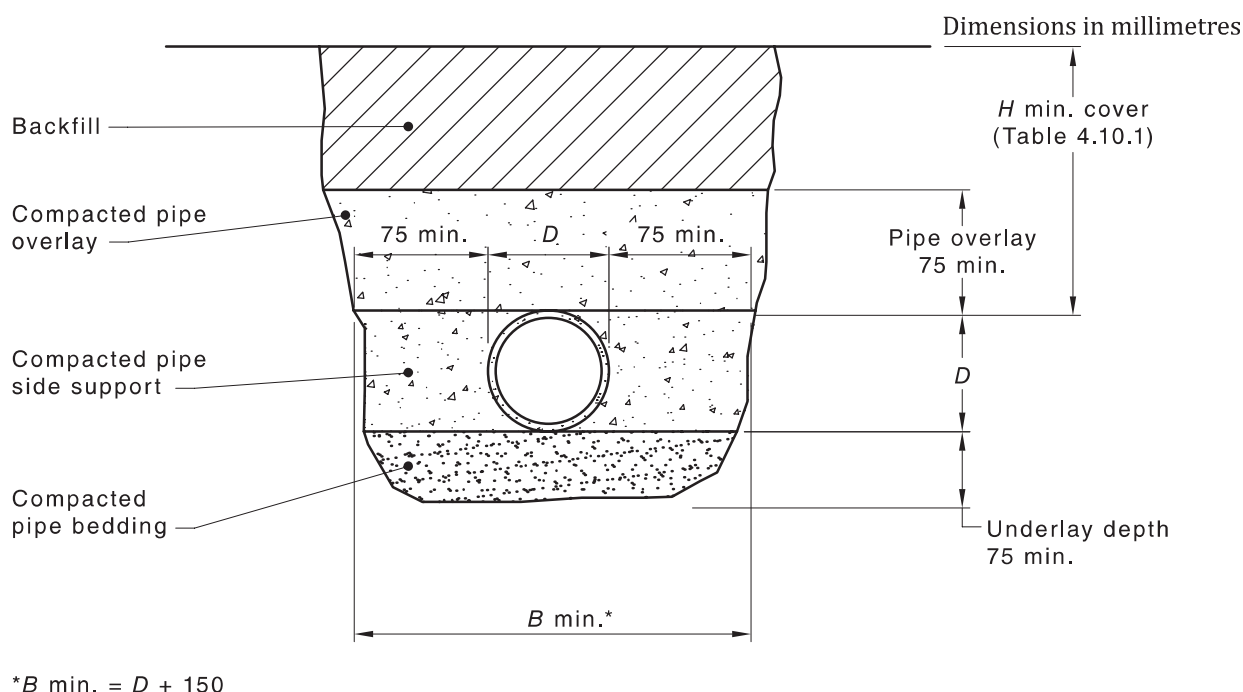


Figure 4.7 — Typical installation in a trench

#### 4.8 Contaminated areas — Installation

Water services shall not be installed in or through a contaminated area unless the water service is —

- laid through a watertight, corrosion-resistant conduit of length and strength adequate to protect the water service; or
- fixed not less than 600 mm above the surface of the ground likely to be contaminated.

NOTE Contaminated areas are areas that may be contaminated by bacterial or chemical pollution and may include ashpits, tanks, ponds, manure bins, waste disposal sites and wastewater treatment works.

#### 4.9 Corrosive areas

Where metallic pipes, metallic fittings or Type M multilayer pipes are installed in a water service in a corrosive area, they shall be externally protected by —

- having an impermeable flexible plastic coating;
- a sealed polyethylene sleeve; or
- fully wrapped in a petrolatum taping material.

NOTE Corrosive areas are those that contain substances such as any compound consisting of magnesium oxychloride (magnesite) or its equivalent, coal wash, acid sulfate soils, sodium chloride (salt), ammonia or materials that could produce ammonia.

#### 4.10 Depth of cover

##### 4.10.1 Depth of cover in public areas

Where heated water services are installed below ground in public areas, the minimum cover shall conform to [Table 4.10.1](#).

**Table 4.10.1 — Minimum cover in public areas for buried piping**

Location	Minimum cover measured below finished surface level, mm
Unpaved	450
Paved or road surface	450
Solid rock	300

#### 4.10.2 Depth of cover in private areas

Where heated water services are installed below ground in private property, the minimum cover shall conform to [Table 4.10.2](#).

**Table 4.10.2 — Minimum cover in private property for buried piping**

Location	Minimum cover measured below finished surface level, mm
Subject to vehicular traffic	300
Under houses or concrete slabs	75
All other locations	225
NOTE Heated water services with flexible joints laid below ground in sandy conditions may require a minimum cover of 600 mm.	

### 4.11 Protection against freezing

#### 4.11.1 Requirement for protection

In areas where the ambient temperature frequently falls to or below 0 °C, water services shall be protected to prevent damage from freezing.

NOTE 1 See also [Section 8](#).

NOTE 2 Information regarding locations which have annual minimum temperatures below 0 °C can be obtained from —

- (a) the Bureau of Meteorology (BOM) in Australia; or
- (b) the National Institute of Water and Atmosphere (NIWA) in New Zealand.

#### 4.11.2 Piping located outside buildings

All pipes and fittings shall be buried to a minimum depth of 300 mm. Where this is not practicable, the piping shall be covered with waterproof insulation.

#### 4.11.3 Pipes located on metal roofs

Pipes shall not be installed in direct contact with metal roofs. Where it is necessary to run piping across a metal roof, it shall be fixed above the roof and surrounded with a waterproof insulation of minimum thickness as given in [Table 4.11.5\(B\)](#) or [Table 8.2.2](#), as appropriate.

NOTE Consideration should be given to the effects of thermal expansion and contraction of the roof material.

#### 4.11.4 Pipes located inside buildings

##### 4.11.4.1 General

Pipes shall be installed so as to avoid those areas of the building that are difficult to keep warm and where temperatures are likely to fall below freezing. These areas include —

- (a) unheated roof spaces;
- (b) unheated cellars;
- (c) locations near windows, ventilators or external doors where cold drafts are likely to occur; and
- (d) locations in contact with cold surfaces, such as metal roofs, metal framework, or external metal cladding materials.

##### 4.11.4.2 Pipes in unheated roof spaces

Pipes in unheated roof spaces shall be located not less than 100 mm from the roof covering and external walls.

NOTE Where practicable, pipes should be located under any insulating material laid for restricting heat losses through the ceilings.

##### 4.11.4.3 Pipes adjacent to external walls

Pipes in external walls shall be positioned not less than 20 mm away from the external surface.

NOTE Where practicable, pipes should be located on the heated side of any wall insulation present.

#### 4.11.5 Insulation of piping and fittings

Where it is necessary to install piping in areas where temperatures are likely to fall below freezing (see [Clause 4.11.4.1](#)), the pipes and fittings shall be surrounded by an appropriate thickness of insulation. The minimum thickness of thermal insulation to prevent freezing of water in pipes shall be in accordance with [Table 4.11.5\(B\)](#).

NOTE 1 Typical examples of materials are given in [Table 4.11.5\(A\)](#).

NOTE 2 If conditions are particularly severe over an extended time, additional thicknesses of insulation may be necessary to prevent water freezing.

NOTE 3 In situations where the building, or part of the building, is not in use over the winter months and no heating of the inside areas is maintained, it may be necessary to drain the pipes to prevent damage by freezing of the water. For effective drainage to occur, it is essential for air to enter freely the pipes, and for all draw-off taps and float valves to be left open when draining is being carried out.

**Table 4.11.5(A) — Typical examples of insulating materials**

Example of material	Thermal conductivity, W/m.K
Rockwool or fibreglass section pipe insulation (prefabricated sections)	0.032
Rockwool or fibreglass loose fill or blanket material	0.032–0.045
Flexible polyethylene foam pipe	0.034–0.040
Closed-cell polymer	0.040
Loose vermiculite (exfoliated)	0.06–0.07

**Table 4.11.5(A)** (continued)

Example of material	Thermal conductivity, W/m.K
Pre-insulated copper pipe	0.070–0.075

**Table 4.11.5(B) — Minimum thicknesses for thermal insulation to prevent freezing of water in pipes**

Pipe size  DN	Minimum thickness required, mm				
	Thermal conductivity of insulating material, W/m.K				
	0.03	0.04	0.05	0.06	0.07
15	9	14	20	29	40
18	6	9	12	15	20
20	4	6	8	10	12
25	3	4	5	6	8
32	2	3	4	5	6

NOTE The insulation thicknesses were calculated using the equations given in BS 5422 to just prevent freezing of water initially at 15 °C if exposed to an ambient temperature of –5 °C for a period of 8 h.

## 4.12 Cold water piping and storage tanks

### 4.12.1 General

The following requirements shall apply to cold water piping to water heaters and storage tanks, and to cold water storage tank piping:

- (a) *Tank connections* — Unions or similar couplings shall be used for the connections to the inlet and outlet of a separately mounted cold water storage tank.
- (b) *Cold water storage tank piping* — Cold water feed piping between a cold water storage tank that is not an integral part of a water heater and the water heater shall —
  - (i) have a nominal size not less than DN 25 for a displacement water heater, and larger than the nominal size of the heater outlet;
  - (ii) be fitted with a gate valve or other full-way valve of the same nominal size as the piping, if the cold water storage tank has a capacity exceeding 50 L; and
  - (iii) be connected to the water heater inlet by unions or similar couplings to facilitate disconnection.

### 4.12.2 Cold water storage tank

#### 4.12.2.1 General

Cold water storage tanks installed to supply water to a water heater shall meet the following requirements:

- (a) They shall be constructed of a material conforming to [Clause 2.3](#) and having equivalent strength and durability to copper sheet of 0.55 mm thickness.
- (b) For metal tanks, they shall —
  - (i) be reinforced along the upper edges to prevent distortion of the tank;
  - (ii) be welded, brazed or soft-soldered at all joints;

- (iii) be independent of the solder for mechanical strength of soldered joints; and
  - (iv) have joints of a type suitable for the water conditions for which the cold water storage tank is intended.
- (c) They shall have a threaded outlet of brass or other suitable material.
- NOTE 1 In Australia, refer to AS ISO 7.1 for information on pipe threads where pressure-tight joints are made on threads.
- NOTE 2 In New Zealand, refer to NZS/BS 21 for information on pipe threads for tubes and fittings where pressure-tight joints are made on the threads.
- The outlet shall be —
- (i) placed as far as practicable from the float valve outlet;
  - (ii) fixed so as to provide a distance of not less than 25 mm between the floor of the tank and the invert of outlet; and
  - (iii) secured into the tank by a method appropriate to the materials to ensure a permanent watertight and mechanically strong connection, which shall not rely on soft solder alone for this purpose.
- (d) They shall be fitted with a float valve.
  - (e) They shall incorporate an air gap in accordance with AS/NZS 3500.1.
  - (f) They shall be clearly and indelibly marked with the static level at which the water is to be set.
  - (g) They shall be fitted with a close-fitting cover, which, in the case of external tanks, shall be secured and of material having corrosion-resisting properties not inferior to 0.5 mm thick galvanized steel sheet.
  - (h) In New Zealand, they shall be seismically restrained against movement in accordance with NZS 4219 or NZBC Acceptable Solution G12/AS1.

NOTE 3 Typical installations of water tanks are shown in [Figures 5.4.5](#) and [5.5.1](#).

NOTE 4 Refer to AS 1910 for information on float control valves for use in heated and cold water.

NOTE 5 Refer to AS 1397 for information on continuous hot-dip metallic coated steel sheet and strip.

#### 4.12.2.2 Water storage tank capacity

Where a displacement water heater or container is supplied from a remote tank, the tank shall have an effective capacity between the outlet and the marked water level not less than the following:

- (a) 36 L for water heaters or containers up to and including 400 L capacity.
- (b) 68 L for water heaters or containers greater than 400 L up to and including 700 L capacity.

NOTE Allowance for extra capacity should be made where the cold water storage tank is required to supply water additional to the supply to the water heater.

#### 4.12.2.3 Flow capacity

The capacity of the float valve and all pressure piping to the float valve and connecting pipes from the cold water storage tank to the water heater or container shall be capable of maintaining a water flow rate of not less than —

- (a) 0.21 L/s (12.5 L/min) for water heaters or containers with volumetric storage capacity up to 400 L; or

- (b) 0.27 L/s (16 L/min) for water heaters or containers with volumetric storage capacity greater than 400 L up to and including 700 L.

This flow rate shall be maintained during the drawing-off of the capacity of the water heater or container without the water level of the cold water feed tank falling to a point that allows air to enter either the water heater or container, or the heated water supply piping.

#### 4.12.2.4 Cold water storage tank overflow

Each cold water storage tank shall be fitted with an overflow conforming to the following requirements:

- (a) The overflow from the cold water storage tank shall be so placed that, with the water in the tank at the marked level, either —
- (i) a further quantity of water, not less than 3 % of the hot water capacity of the heater, can be added before overflow occurs; or
  - (ii) there shall be no discharge from the overflow during the initial heating of the water through a 70 °C temperature rise.
- (b) The overflow from an internally mounted cold water storage tank shall discharge into —
- (i) the safe tray of the cold water storage tanks, terminating not less than 20 mm above the top edge of the safe tray; or
  - (ii) into the waste from the safe tray at a point not less than 75 mm below the floor of the safe tray.
- (c) The overflow shall be constructed so that with the float valve discharging at its maximum flow, with water pressure of 700 kPa and with all service outlets closed, no spillage occurs from the cold water storage tanks. The vertical distance between the static overflow level and the lowest outlet of the float valve shall be in accordance with AS/NZS 3500.1.
- (d) The overflow from an externally mounted cold water storage tank shall —
- (i) discharge so as to be readily discernible and not cause a nuisance over windows, open doors or incur damage to buildings or injury to persons; and
  - (ii) be installed in a manner to prevent blockage due to freezing.

#### 4.12.2.5 Position of cold water storage tanks

Cold water storage tanks shall be placed in accordance with the following:

- (a) *Mounted on water heater* — Where the water heater is supplied complete with an attached cold water storage tank that is connected to the container, the tank shall not be removed from that position.
- (b) *Separately mounted* — Each separately mounted cold water storage tank shall be placed so that the vertical distance from the marked water level of the tank to the base of the water heater or container does not exceed a height equivalent to the maximum pressure rating marked on the water heater.

NOTE See also [Clause 4.13.5\(c\)](#).

### 4.12.3 Safe tray for cold water storage tanks

Cold water storage tanks fixed in a roof space or other concealed space shall be placed on a safe tray conforming to [Clause 5.4.3](#). Where the tank is mounted on the water heater, a water heater safe tray conforming to [Clause 5.4](#) shall be deemed acceptable as the safe tray for the cold water storage tanks.

NOTE In New Zealand, safe trays are only required where leakage could result in damage to another occupancy in the same building.

### 4.12.4 Support for separately mounted cold water storage tanks

#### 4.12.4.1 Platform

Each separately mounted cold water storage tank shall be supported on a platform conforming to [Clause 5.5](#).

#### 4.12.4.2 Spacing between cold water storage tank and safe tray

The cold water storage tank shall be placed on the safe tray on supports in accordance with [Clause 5.4.5](#).

## 4.13 Installation of heated water services

### 4.13.1 Design and installation

Water flow velocities in heated water piping shall be in accordance with [Clause 1.8](#).

NOTE 1 See [Table 10.3.2](#) for minimum rates of flow.

NOTE 2 See [Appendix D](#) for preferred sizes of pipes ([Table D.1](#)).

NOTE 3 Where the distance between hot water outlets causes an excessive amount of dead water, the use of two or more heaters, trace heating of pipes or a heated water circulatory system should be considered.

NOTE 4 See [Clause 4.13.4](#) for gradient requirements.

NOTE 5 For New Zealand, refer to NZS 4305 for pipe lengths from cylinders to kitchen outlets.

NOTE 6 [Appendix M](#) provides guidelines for the operation and maintenance of heated water services.

**C4.13.1** *In the interests of amenity and water efficiency, the design of a heated water system should also —*

- (a) *reduce to a minimum the amount of dead (cold) water drawn off before hot water commences to flow at any tap;*
- (b) *be sufficient to give the required flow at all outlets (including branches from non-circulatory services);*
- (c) *be by the shortest practicable route for the main flow heated water pipes and branches to the heated water outlets; and*
- (d) *be the minimum necessary diameter of the heated water pipes required to supply the outlet draw-off.*

#### 4.13.2 Identification of piping

Accessible pipework shall be permanently marked so as to be readily identifiable as part of the heated water service within:

- (a) In Australia, all Class 2 to Class 9 buildings (multi-unit, commercial and industrial buildings).
- (b) In New Zealand —
  - (i) multi-unit dwellings, including apartment buildings but excluding low rise multi-unit dwellings such as an attached dwelling or flat;
  - (ii) communal residential buildings, excluding holiday cabins and backcountry huts;
  - (iii) communal non-residential buildings;
  - (iv) commercial buildings; and
  - (v) industrial buildings.

NOTE 1 In Australia, refer to the NCC for information on building classes.

NOTE 2 In New Zealand, refer to NZBC Clause A1 Classified Uses for information on building use categories.

Identification markings shall be placed —

- (i) at spacings not exceeding 6 m;
- (ii) adjacent to branches, junctions, valves, service appliances, bulkheads, and wall and floor penetrations; and
- (iii) at every floor level within vertical ducts and riser cupboards.

NOTE 3 Refer to AS 1345 for information on identification tags and labels in Australia.

NOTE 4 Refer to NZS 5807 for information on identification marking in New Zealand.

#### 4.13.3 Provision for expansion

Heated water supply pipes shall be installed with allowance for expansion and contraction and have —

- (a) a free length of piping around the bend or along the branch sufficient to prevent overstressing the pipe and allow for thermal expansion;
- (b) a clear space to allow movement for expansion as calculated and have unrestrained offsets at changes in direction;
- (c) expansion loops at or near midpoint in straight lengths that exceed 18 m; or
- (d) expansion joints fitted.

Expansion loops shall be placed horizontally to avoid forming air locks at the top of the loops and to ensure circulation of the water.

The rates of thermal expansion for common pipe materials shall be calculated in accordance with [Appendix N](#).

#### 4.13.4 Gradient

The grading of a heated water reticulation service shall conform to the following:

- (a) *Mains pressure or pressure-limiting valve-controlled reticulation* — rise or fall as required subject to the requirements of [Clause 4.13.5](#).

- (b) *Reducing valve-controlled reticulation* — rise and fall as required subject to the provisions of [Table 4.13.4](#).
- (c) *Cold water storage tank-fed reticulation* — rise or fall continuously in the direction of flow with a minimum grade of 1 in 200.

**Table 4.13.4 — Maximum rise**

Reducing valve setting kPa	Highest point of reticulation above reducing valve outlet m
25	1.5
30	1.75
35	2.0
40	2.5
45	2.75
50	3.0
70	4.5
100	6.5

#### 4.13.5 Maximum rise of heated water supply pipes

The maximum rise of heated water supply pipes shall be as follows:

- (a) *For mains pressure reticulation* — 60 % of the available mains pressure, expressed in metres head, above the level of the cold water inlet.
- (b) *For pressure-limiting valve or pressure-reducing valve-controlled reticulation* — 60 % of the valve setting, expressed in metres head, above the level of the cold water inlet.
- (c) *For cold water storage tank-fed reticulation* — 1 m below the marked water level of the cold water storage tank.

NOTE For the purpose of this clause, 10 kPa = 1 m head should be used.

#### 4.13.6 Shower assemblies

Where the heated water is at a lower pressure than the cold water, the heated and cold water mixing assembly shall be constructed so that the cold water flow does not restrict the heated water flow.

#### 4.13.7 Venting of secondary circuit

Each low-pressure-fed secondary circuit shall be vented at the highest point of the rise on the secondary flow pipe by either —

- (a) a vertical vent pipe conforming to [Clause 5.12](#); or
- (b) an automatic air elimination device suitable for that purpose.

#### 4.13.8 Recirculation of cold water

A heated water return line may be returned to the water heater inlet by either —

- (a) connecting between the non-return valve and the water heater; or

NOTE For typical arrangements of the above, see [Figures 5.10.2\(A\)](#) and [5.10.2\(B\)](#).

- (b) connecting to the cold water pipes using a device that will prevent heated water from entering the cold water pipes.

## Section 5 Installation of water heaters — General requirements

### 5.1 Scope of section

This section sets out general requirements for the installation of water heaters, their location, support, cold water service valves, the vent or drain lines and the first 2 m of heated water supply piping.

NOTE For energy efficiency requirements, see —

- (a) [Section 8](#); and
- (b) in Australia, the National Construction Code; or
- (c) in New Zealand, New Zealand Building Code Clause H1 Energy Efficiency.

### 5.2 Water heaters

#### 5.2.1 Selection of anode

Any anode fitted to a water heater shall be compatible with the water supplied to the water heater.

NOTE 1 See [Clause 1.6](#) for water chemistry requirements and [Appendix A](#) for water analysis recommendations.

NOTE 2 Refer to the water heater manufacturer for information on the suitability of the anode.

#### 5.2.2 Working pressure

Water heaters shall be installed so that the maximum rated working pressure is not exceeded during normal operation.

NOTE Maximum rated working pressure should be listed on the heater label affixed by the manufacturer.

### 5.3 Location

#### 5.3.1 Placement

The water heater shall be placed as close as practicable to the most frequently used outlet point or points. Consideration shall be given to the route taken by vent pipes, drain lines or safe wastes.

#### 5.3.2 Accessibility and clearances

Water heaters shall be located and oriented in accordance with the following:

- (a) The rating plate and instruction notice shall be in a visible position.
- (b) Unobstructed access shall be available to the burner, heating units, controls, cold water storage tanks and other apparatus requiring maintenance.
- (c) All valves and the easing gear on a relief valve shall be readily accessible.
- (d) There shall be 150 mm minimum clearance from the end of the easing gear of temperature/pressure-relief valves to allow for valve removal.
- (e) The heater shall be subsequently removable without major structural alteration to the building or major alteration to the piping.

NOTE 1 Wherever practicable, clearance should be allowed for removal and replacement of anodes, where fitted.

NOTE 2 See [Clause 4.13.4](#) for cold water storage tank-fed water heaters.

### 5.3.3 Ventilation and fluing

Fuel-burning water heaters shall be located to provide the correct ventilation and fluing.

## 5.4 Protection against damage from leaking water

### 5.4.1 Concealed water storage tanks

All water containers, cold water storage tanks, cold water storage tank-fed water heaters or storage water heaters that are installed in roof spaces, in cupboards or otherwise concealed shall be placed on safe trays conforming to [Clause 5.4.3](#). The safe trays shall be drained by safe wastes conforming to [Clause 5.4.4](#).

Notwithstanding the above requirements, mains pressure water heaters may be installed on a safe tray without a safe waste, provided a leak protection device is fitted adjacent to the cold water inlet and upstream of any expansion control valve.

NOTE See [Clause 5.9.4\(f\)](#) and [Figures 5.9.4\(A\)](#) to [5.9.4\(D\)](#) for typical valve installations.

### 5.4.2 Unconcealed water storage tanks

Unconcealed water storage tanks, installed inside buildings on or above a floor surface that is impervious to water and suitably drained to a trapped or untrapped floor drain or an external doorway, do not require safe trays.

A mains pressure water heater with a leak protection device fitted adjacent to the cold water inlet and upstream of any expansion control valve does not require a safe waste.

All other unconcealed water storage tanks that are installed inside buildings shall be installed with safe trays conforming to [Clause 5.4.3](#) and safe wastes conforming to [Clause 5.4.4](#).

NOTE Free outlet-type storage water heaters not exceeding 13.5 L capacity and instantaneous water heaters do not require safe trays.

### 5.4.3 Safe tray construction

Safe trays shall be fabricated from materials that conform to the requirements of [Clause 2.6.1](#). The sides of the safe tray shall be turned up not less than 50 mm. All joints shall be made watertight.

### 5.4.4 Safe wastes

#### 5.4.4.1 Sizes of safe wastes

The minimum sizes of safe wastes shall be —

- (a) DN 25 for safe trays in under-sink situations; or
- (b) DN 50 (DN 40 New Zealand only) for all other situations.

#### 5.4.4.2 Safe waste construction

Safe wastes shall be fabricated with all joints in sheet metal pipe lapped in the direction of the flow and all circumferential joints made watertight.

#### 5.4.4.3 Safe waste installation

Each safe waste shall conform to the following:

- (a) It shall have a continuous fall to its discharge point.

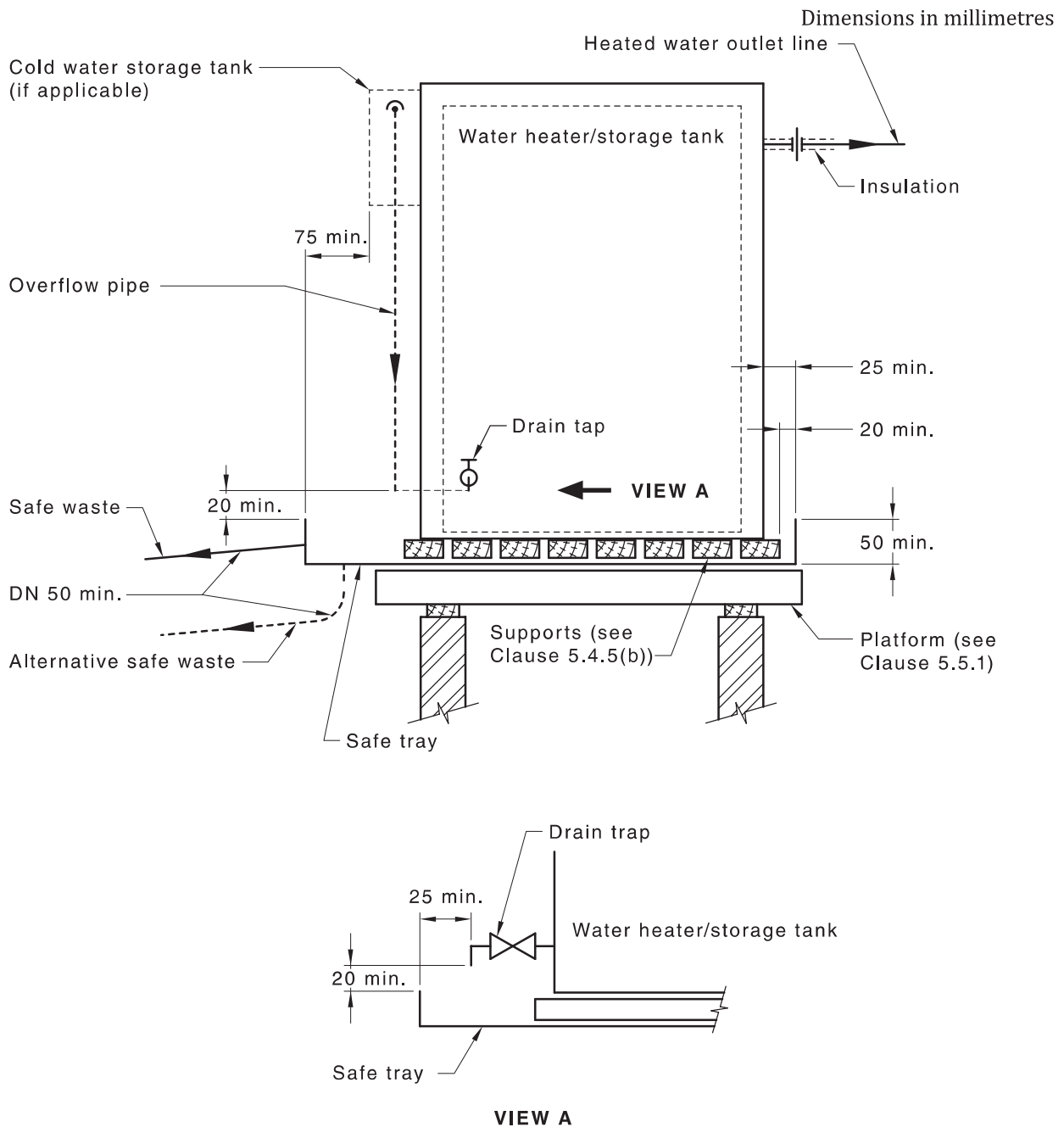
- (b) All seams in sheet metal pipe shall be uppermost.
- (c) It shall include support in the vicinity of the tray and at intervals not greater than 1 m horizontally and 2.4 m vertically.
- (d) The discharge position shall conform to the following:
  - (i) Where discharging outside the building, it shall discharge to a point within the property boundaries that is readily visible from within the property, clear of doors, windows and other openings and is unlikely to cause injury to people or damage to property.
  - (ii) Where discharging inside the building, it shall discharge to a readily visible position that is unlikely to cause injury to people or damage to property.
  - (iii) Where cold water storage tanks or cold water storage tank-fed water heaters are outside the building, it shall discharge to a readily visible position.

#### 5.4.5 Placement of water heater or cold water storage tank on a safe tray

The water heater or cold water storage tank shall be placed on a safe tray and conform to the following:

- (a) It shall have no portion of any attached feed tank closer than 75 mm to a vertical line from the edge of the safe tray and no portion of the heater or cold water storage tank or any attached auxiliary part closer than 25 mm to the vertical line.
- (b) It shall have placed, between the tank and the safe tray, supports not less than 12 mm thick and of an area not less than  $0.5A$ , nor more than  $0.6A$ , where  $A$  is the area of the base of the tank. The support shall project beyond the sides and walls of the tank but not closer than 20 mm to the sides of the safe tray.

NOTE See [Figure 5.4.5](#) for a typical installation of a safe tray, including position of water heater or cold water storage tank.



**Figure 5.4.5 — Typical installation of a safe tray and position of water heater or cold water storage tank**

## 5.5 Support

### 5.5.1 Support of water storage tanks installed in a roof

Storage water heaters and cold water storage tanks installed in a roof space shall be placed on a safe tray that is supported by a platform of hardwood or other suitable and not less durable material, and conforming with the following requirements:

- (a) The safe tray shall drain to its safe waste.
- (b) The safe tray shall be placed so that the load of the water heater or cold water storage tank is supported by one or more loadbearing walls that are vertically continuous to a solid

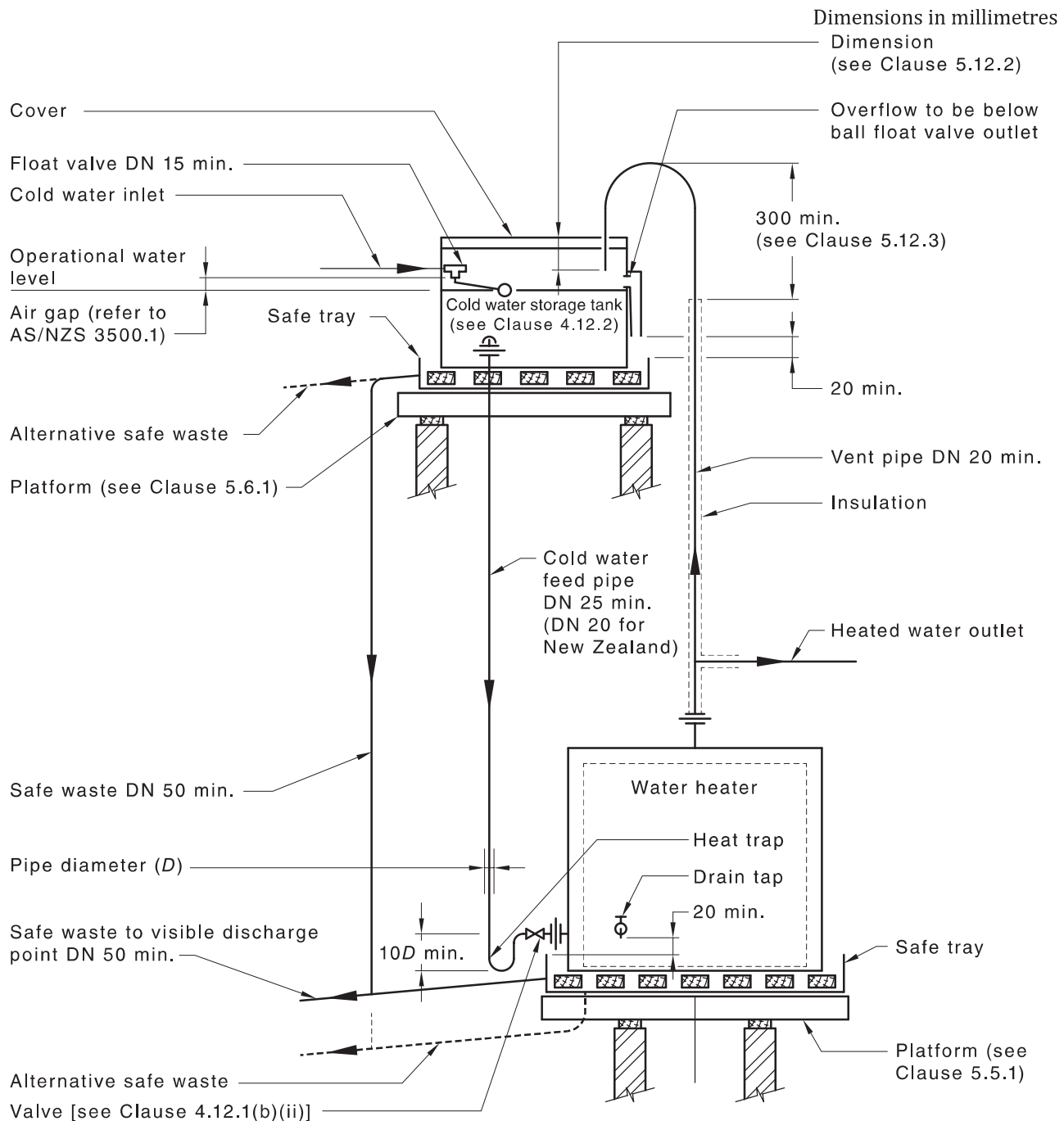
foundation, a concrete slab or similar support of comparable strength. The location of the safe tray shall be in accordance with the following:

- (i) Where the platform is placed over one wall only, it shall be placed centrally over the wall. Any ceiling joist that is subjected to additional stress shall cross the wall at right angles. The capacity of the water heater or cold water storage tank, or both, supported by the platform shall not exceed 450 L.
  - (ii) Where the load is carried by beams or bearers spanning two walls, no ceiling joists shall carry any of the load, except where immediately over a wall.
  - (iii) Where the load is carried on loadbearing walls supported on piers, the water heater or cold water storage tank shall be placed centrally above a solid pier that supports the wall immediately under the water heater or cold water storage tank, or the load shall be transmitted to a designed floor beam or bearer supported by two piers not more than 2 m apart.
- (c) Where the roof is constructed from trusses, the platform supporting a water storage tank shall not be supported from any part of the trusses unless the trusses are specifically designed to carry the load of the water storage tank.

NOTE 1 These requirements do not preclude the load or part of the load from being carried on a beam or bearer that spans an opening in a wall. As such, the wall immediately above the opening is not subjected to additional stress and the load is distributed over at least 0.6 m of vertical continuous wall on either side of the opening.

NOTE 2 See [Figure 5.5.1](#) for typical installation of water tank in roof space.

NOTE 3 See [Figure 5.5.3](#) for typical platform construction.



**Figure 5.5.1 — Typical installation in roof space of cold water storage tank-fed water heater with separately mounted cold water storage tank**

### 5.5.2 Support of water heaters or water storage tanks installed above a roof

Storage water heaters (other than solar water heaters) and cold water storage tanks installed above a roof shall be supported on a platform that is not less durable than timber conforming to [Clause 2.8.1](#) and the following:

- The clearance between the lowest part of the platform and the roof shall be not less than 75 mm.
- The load shall be distributed over two walls continuous to a solid foundation without any stress being placed on the roof structure.

- (c) The support shall have structural members that penetrate the roof, flashed or rendered watertight in a manner that will allow for expansion.

NOTE In cyclone-prone areas, further regulatory requirements may also apply.

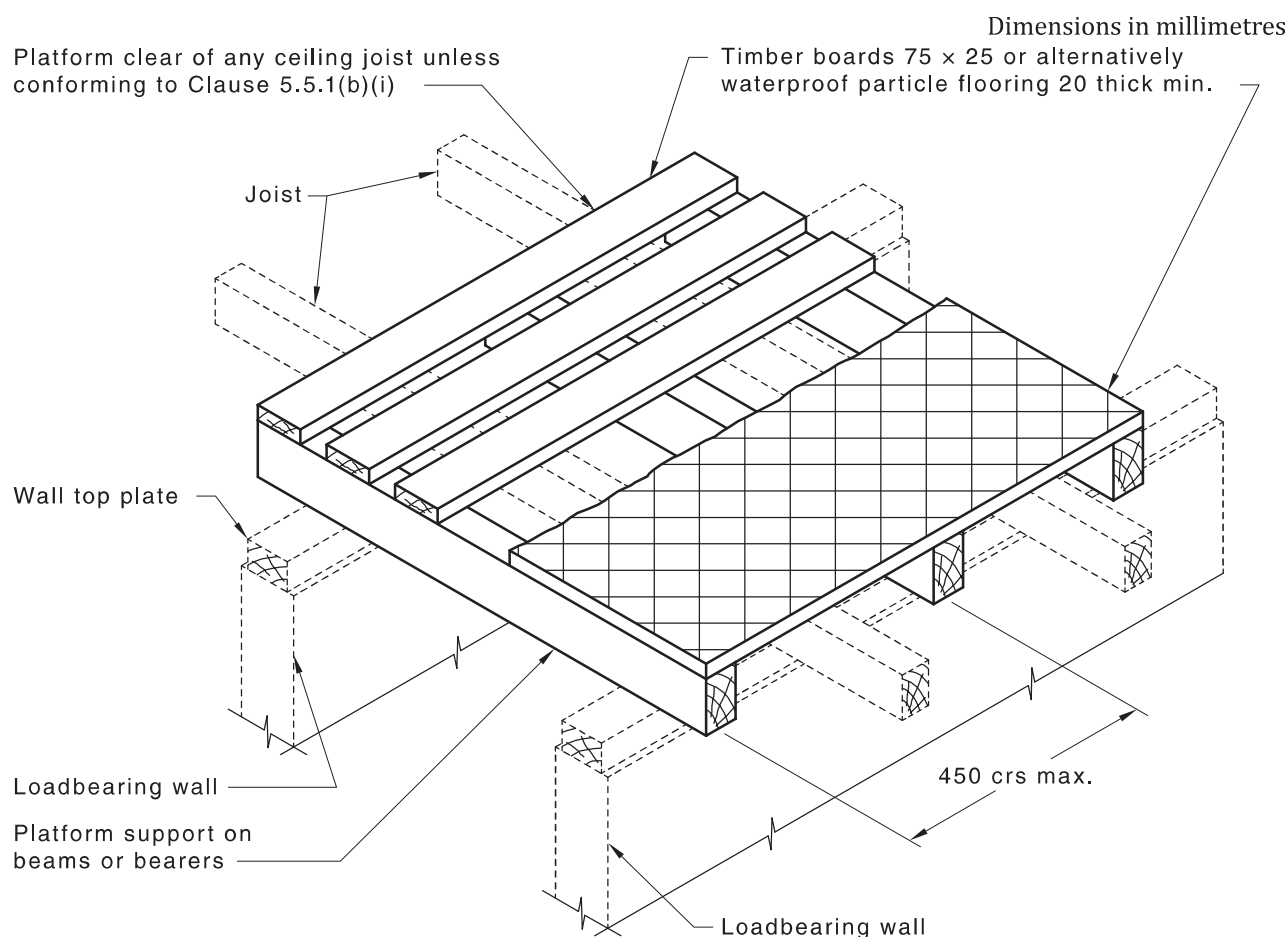
### 5.5.3 Support of water heaters or water storage tanks installed other than in a roof space or above a roof

Storage water heaters and cold water storage tanks installed other than in a roof space or above a roof shall be floor-mounted or supported as follows:

- (a) By brackets or hangers, designed to withstand the applied load.
- (b) On a level, stable and impervious base designed and located to avoid ponding and made of —
- (i) bonded brick or concrete cast *in situ*, having a thickness of not less than 75 mm; or
  - (ii) pre-cast concrete having a thickness of not less than 50 mm.
- (c) On a platform of timber, or other suitable and not less durable material. Where such a platform is located at or near ground level, it shall be supported so that a clearance of not less than 100 mm is maintained from the surrounding ground.

NOTE A typical platform construction is shown in [Figure 5.5.3](#).

- (d) In a recess in a wall structure able to withstand the applied load.



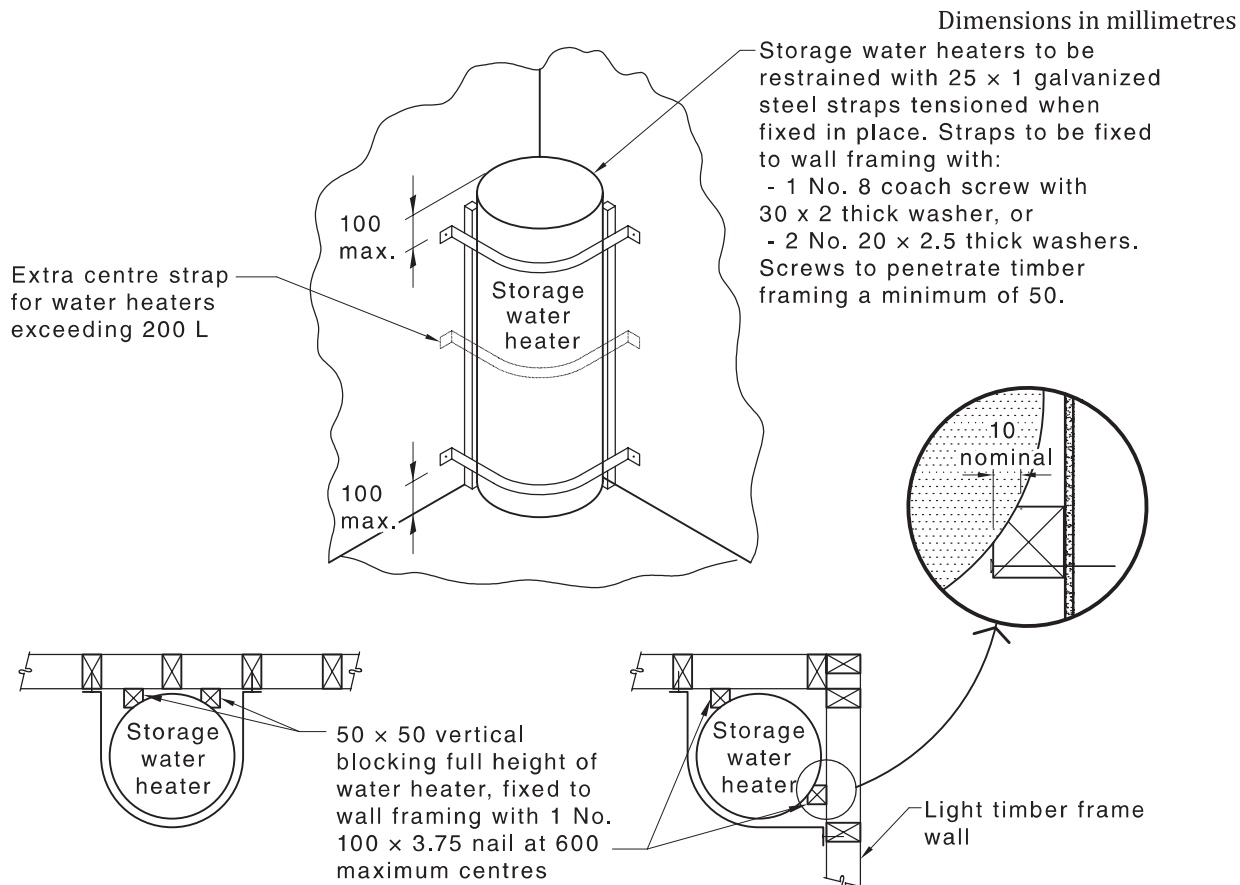
**Figure 5.5.3 — Typical construction of a platform**

### 5.5.4 Seismic restraints

In New Zealand, cold water storage tanks and storage water heaters shall be restrained against movement in accordance with NZS 4603, NZS 4607, or NZS 4219.

NOTE 1 Refer to NZBC Acceptable Solution G12/AS1 for seismic restraint requirements.

NOTE 2 See [Figure 5.5.4](#) for a typical arrangement for seismic restraint of storage water heaters.



**Figure 5.5.4 — Typical arrangement for seismic restraint of storage water heaters less than 350 L (New Zealand only)**

## 5.6 Corrosion prevention and weather protection

### 5.6.1 Water heater base — Corrosion avoidance

Water heaters located on surfaces that may become wet shall be installed to allow free air circulation between the surface and the base of the water heater except where the base of the water heater is constructed from a material that protects against corrosion.

### 5.6.2 Weather protection of externally installed water heaters

Water heaters installed externally shall be —

- (a) of a type designed for external installation; or
- (b) protected by a weatherproof enclosure.

NOTE A water heater or enclosure conforming to the above requirements may not necessarily be suitable for extreme conditions, such as sustained freezing temperature or for salt-laden or corrosive atmospheres. For installations under such conditions, refer to the water heater manufacturer.

## 5.7 Connections to water heaters

Unions or similar couplings shall be provided for the connections of any service pipe to the inlet or outlet of the water heater.

## 5.8 Pressure relief and venting of water heaters and containers

For the pressure relief and venting of water heaters and containers the following requirements apply:

- (a) The storage container of a vented storage water heater shall be fitted with a free and unobstructed vent open to the atmosphere at all times.
- (b) A vented heat exchange water heater shall be fitted with a vent and protective devices.
- (c) An unvented storage water heater shall be fitted with a temperature/pressure-relief valve.
- (d) An unvented pressure water container not designed to withstand a full vacuum shall be fitted with a vacuum-relief valve.

NOTE 1 Where the water supply is scaling in nature, an expansion control valve or expansion vessel should be incorporated in the installation of an unvented water heater, otherwise the temperature/pressure-relief valve may become blocked due to the deposition of calcium carbonate from the heated water that is relieved during thermal expansion, see [Figures 5.9.4\(C\)](#) and [5.9.4\(D\)\(a\)](#).

NOTE 2 For instantaneous water heaters see also [Clause 5.9.1](#) for valve requirements.

NOTE 3 In New Zealand only, when the valve set pressure is not greater than 120 kPa, a pressure-relief valve may be used in lieu of a temperature/pressure-relief valve.

NOTE 4 In New Zealand, expansion control valves or an expansion vessel are required to be fitted to all unvented (i.e. valve vented) cylinders.

NOTE 5 A vacuum-relief valve is usually incorporated in the pressure-relief valve on a container that is not designed to withstand a full vacuum.

NOTE 6 In New Zealand, "valve vented" describes water heaters that are vented by valves rather than by an open vent pipe.

NOTE 7 See [Clause 5.10.3\(b\)\(ii\)](#) for location and capacity of expansion vessels.

NOTE 8 Refer to AS 3498 for information on water heaters and heated water storage tanks.

## 5.9 Valves and expansion vessels

### 5.9.1 General

The valves and expansions vessels used in the installation of water heaters shall conform to [Table 5.9.1\(A\)](#).

Table 5.9.1(A) — Valve and expansion vessel requirements for water heaters

Valves and expansion vessels	Valves and expansion vessel requirements								Heat exchange water heater d
	Instantaneous water heaters		Unvented water heater		Vented water heater				
	Mains pressure a	Unvented reduced pressure b	Vented reduced pressure c	Reduced pressure uncont. heat source	Free outlet water heater	Side-fed water heater	Heat exchange water heater d		
Isolating valve	Yes e	Yes	Yes	Yes	Yes	Yes	Yes	Yes	
Non-return valve	N/A	Yes	Yes	Yes	Yes	N/A	Yes	Yes	
Pressure-limiting valve	f	f	N/A	N/A	N/A	N/A	f	f	
Pressure-reducing valve	N/A	Yes	Yes	Yes	N/A	N/A	N/A	N/A	
Expansion control valve or expansion vessel (Australia only)	N/A	g	N/A	N/A	N/A	N/A	Yes	Yes	
Expansion control valve or expansion vessel (New Zealand only)	N/A	Yes	N/A	N/A	N/A	N/A	Yes	Yes	
Temperature/pressure-relief valve h	N/A	Yes	N/A	N/A	N/A	N/A	N/A	N/A	

**Key**

N/A = Not applicable

a See [Figures 5.9.4\(B\)](#) and [5.9.4\(C\)](#).

b See [Figure 5.9.4\(D\)](#) (a).

c See [Figure 5.9.4\(D\)](#) (b).

d See [Figure 5.9.4\(B\)](#).

e Isolating valves shall provide full flow.

f As required by [Table 5.9.1\(B\)](#).

g See [Clause 5.8](#) Note 1.

h In New Zealand, where the valve set pressure is not greater than 120 kPa, a pressure-relief valve may be used in lieu of a temperature/pressure-relief valve.

NOTE 1 This table is not applicable to a water heater fed from a remote cold water storage tank.

NOTE 2 For Australian valve requirements, refer to AS 1357; for New Zealand valve requirements, refer to NZS 4608.

Table 5.9.1(B) — Set pressures for valves

Temperature/ pressure-relief valve or pressure- relief valve setting	Without expansion control valve		With expansion control valve			Inlet pressure control valve type required
	Maximum mains pressure	Inlet valve maximum setting	Exp. control valve setting	Maximum mains pressure	Inlet valve maximum setting	
kPa	kPa	kPa	kPa	kPa	kPa	
Open vent	N/A	35	N/A	N/A	N/A	Pressure reducing
56	N/A	45	46	N/A	35	Pressure reducing
74	N/A	65	65	N/A	55	Pressure reducing
Open vent	N/A	76	N/A	N/A	N/A	Pressure reducing
80	N/A	65	65	N/A	50	Pressure reducing
85	N/A	70	70	N/A	55	Pressure reducing
100	N/A	85	85	N/A	70	Pressure reducing
115	N/A	100	100	N/A	85	Pressure reducing
120	N/A	110	110	N/A	100	Pressure reducing
130	N/A	115	115	N/A	100	Pressure reducing
150	N/A	130	130	N/A	115	Pressure reducing
180	N/A	160	160	N/A	140	Pressure reducing
215	N/A	195	195	N/A	175	Pressure reducing
500	400	350	400	350	300	Pressure limiting
700	550	450	550	450	350	Pressure limiting
850	680	500	700	550	450	Pressure limiting
1 000	800	600	850	680	500	Pressure limiting
1 200	960	600	1 000	800	600	Pressure limiting
1 400	1 120	600	1 200	960	600	Pressure limiting
N/A	N/A	N/A	1 400	1 100	600	Pressure limiting

NOTE Where the maximum mains pressure is likely to be exceeded, inlet pressure-control valve shall be used.

### 5.9.2 Required set pressure of valves (for unvented water heaters)

The required set pressure of expansion control valves, expansion vessels and inlet-pressure-control valves shall be determined from the set pressure of the temperature and pressure-relief valve supplied with the water heater with reference to [Table 5.9.1\(B\)](#).

### 5.9.3 Set pressure of expansion vessels

The set pressure of expansion vessels shall be determined in accordance with [Appendix P](#).

### 5.9.4 Installation of valves and expansion vessels

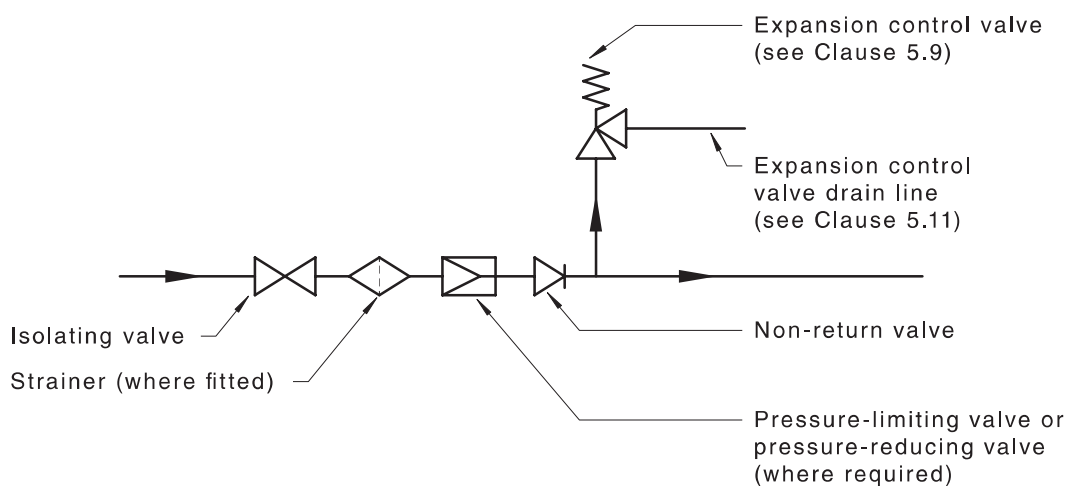
Valve and expansion vessel installations shall —

- have the isolating valve in a position readily accessible from floor or finished surface level;
- have the cold water supply valves (where fitted) in the sequence isolating valve, line strainer, pressure control valve, non-return valve, expansion control valve or expansion vessel or as a combined unit;
- have unobstructed access for maintenance or replacement and meet the requirements of Items (c) and (d) of [Clause 5.3.2](#);

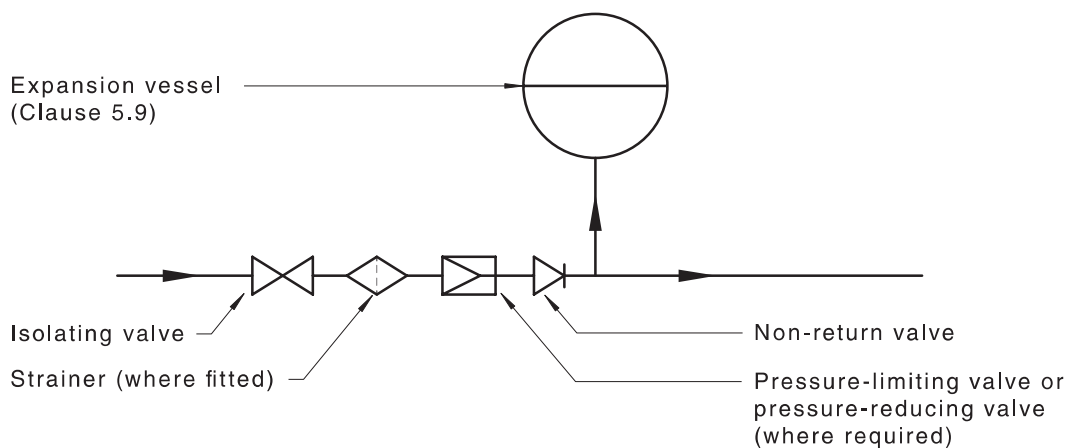
- (d) have no heat applied to any valve that has screwed pipe connections;
- (e) have no other valve, tap or shut-off device between the temperature/pressure-relief valve, pressure-relief valve or expansion vessel and the water heater;
- (f) except for the heater isolating valves required in [Clause 5.10.2\(h\)](#) for multiple installations, have no other valve, tap or shut-off device between any expansion control valve or expansion vessel and the inlet to the water heater;
- (g) have the temperature/pressure-relief valves fitted in the position identified on the water heater; and
- (h) be protected from freezing in accordance with [Clause 4.11](#).

NOTE 1 See [Figure 5.9.4\(A\)](#) for typical sequence of valve installation.

NOTE 2 See [Figures 5.9.4\(B\)](#) to [5.9.4\(E\)](#) for typical valve installations.



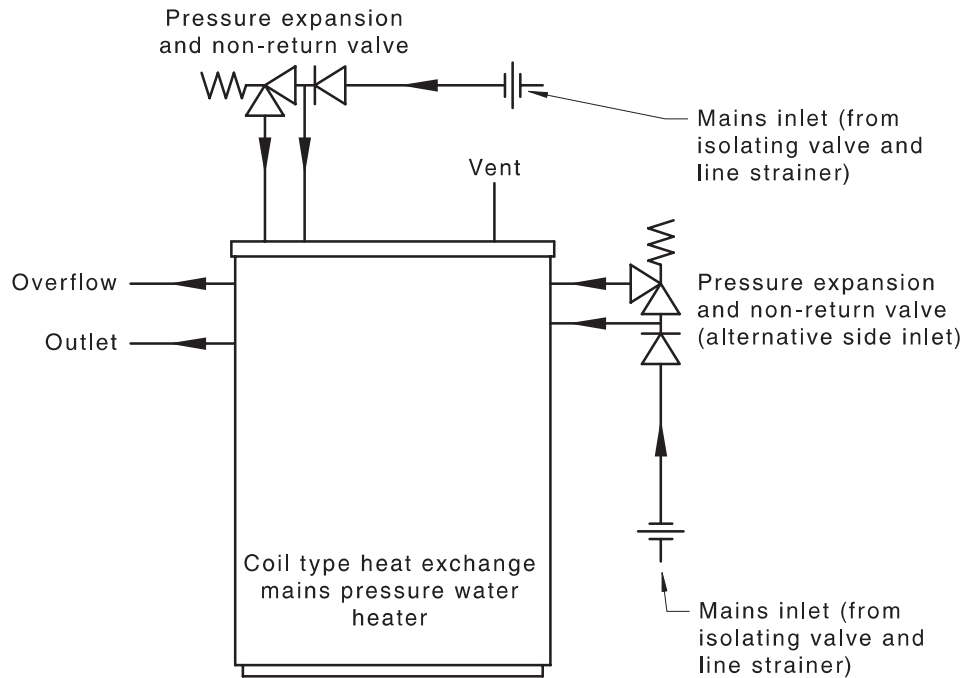
(a) Typical assembly incorporating a pressure-limiting or pressure-reducing valve using expansion control valve



(b) Typical assembly with no pressure-limiting or pressure-reducing valve using an expansion vessel

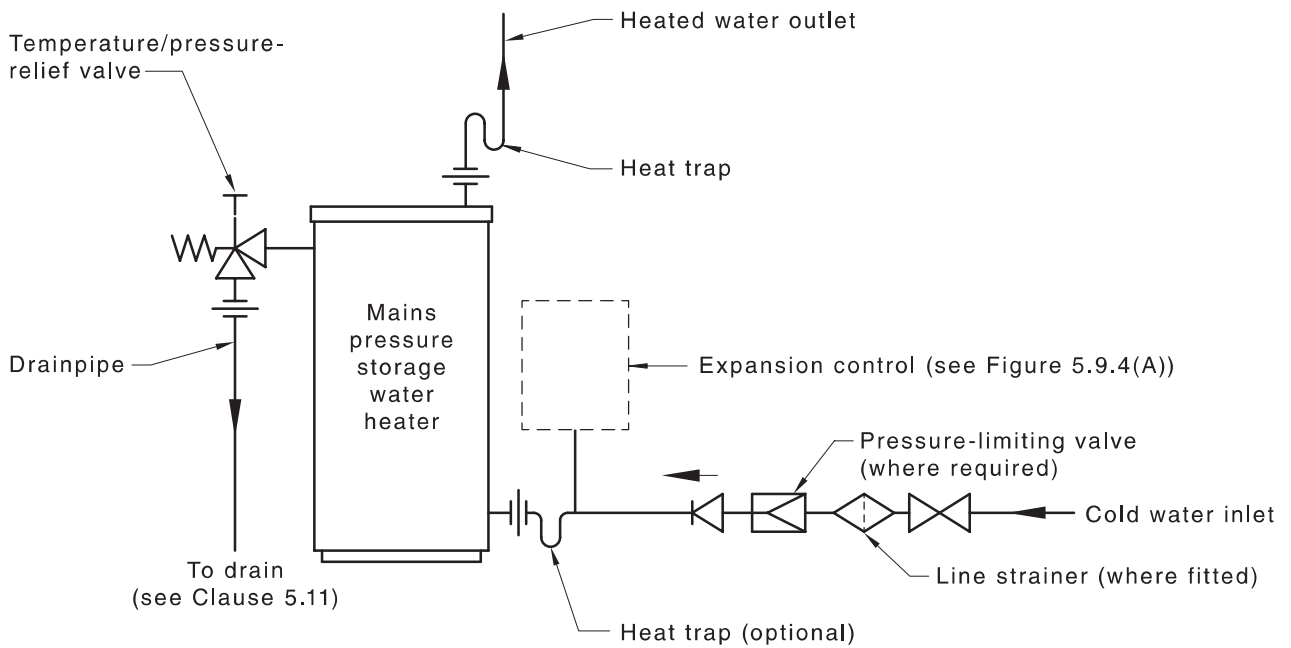
NOTE Expansion control valve may be combined with the pressure-limiting valve.

**Figure 5.9.4(A) — Typical installation of valves**

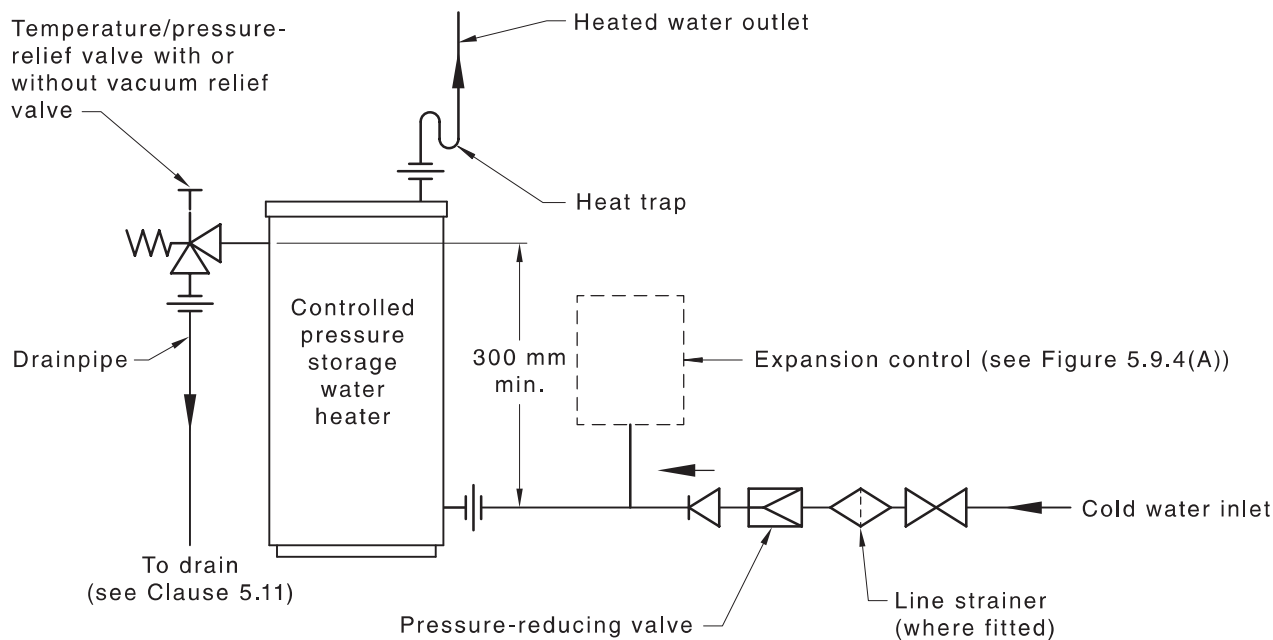


NOTE Expansion control valve may be combined with the pressure-limiting valve.

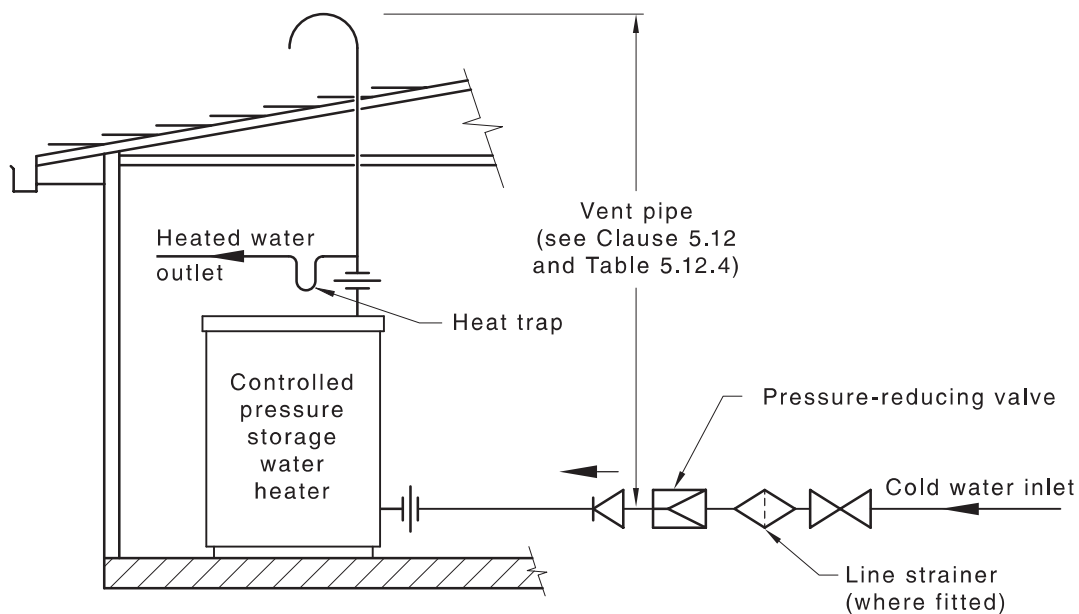
**Figure 5.9.4(B) — Typical installation of a heat exchange mains pressure water heater fitted with a combination expansion control valve and non-return valve**



**Figure 5.9.4(C) — Typical installation of a mains pressure storage water heater**

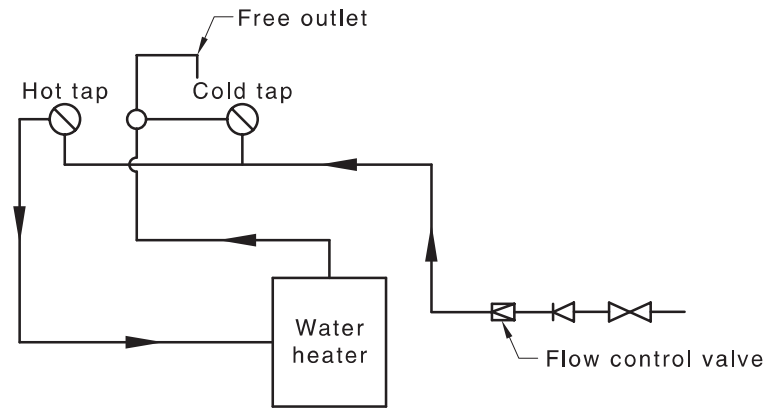


(a) With temperature/pressure-relief and vacuum-relief valves

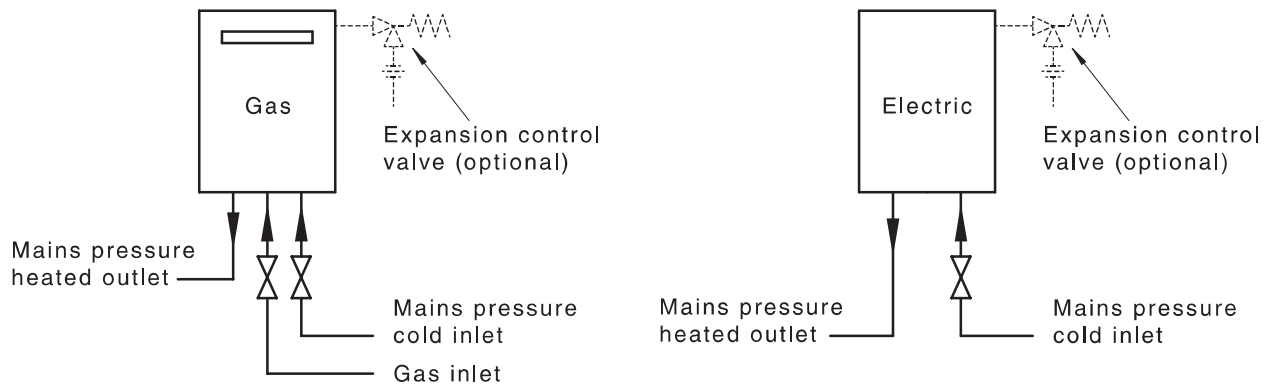


(b) With vent pipe

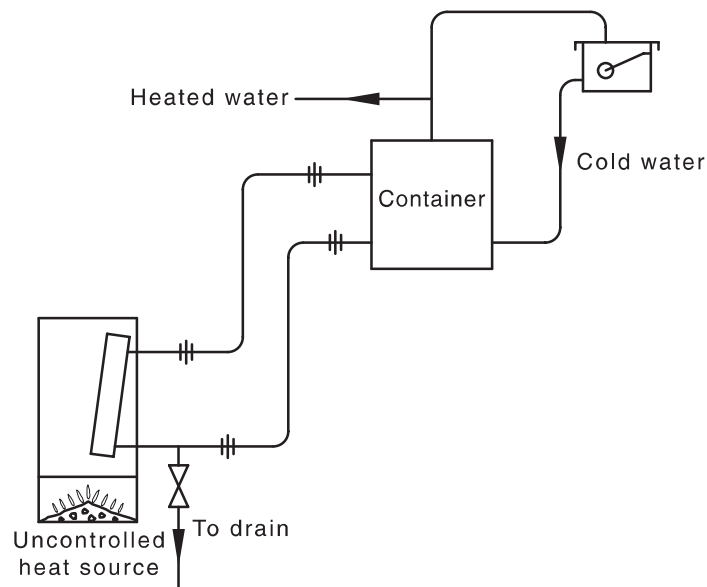
**Figure 5.9.4(D) — Typical installation of a pressure water heater controlled with a pressure-reducing valve**



(a) Free outlet under-sink water heater



(b) Instantaneous water heater



(c) Uncontrolled water heater

NOTE See [Figure 5.9.4\(A\)](#) for expansion control, where installed in conjunction with a heated water vessel.

**Figure 5.9.4(E) — Typical water heater arrangements**

## 5.10 Multiple installations of pressure-type storage water heaters

### 5.10.1 General

Where large volumes of hot water are required over a short period, several pressure-type storage water heaters may be combined into one service.

Each water heater shall be fitted with temperature/pressure-relief valves in accordance with [Table 5.9.1\(A\)](#).

In all such installations, access shall be provided in front of each water heater for the servicing and removal of any one water heater without the need to disconnect any others.

### 5.10.2 Balanced flow conditions

Banks of storage water heaters shall be installed in accordance with the following to ensure similar resistance to flow through all the heaters in the bank and that each delivers similar volumes of hot water at a similar temperature:

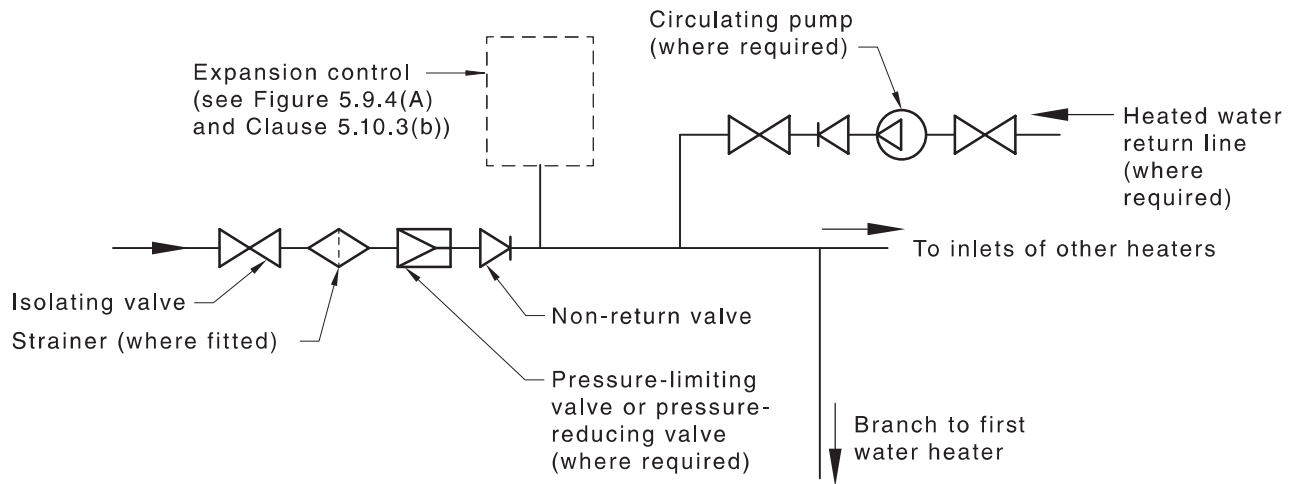
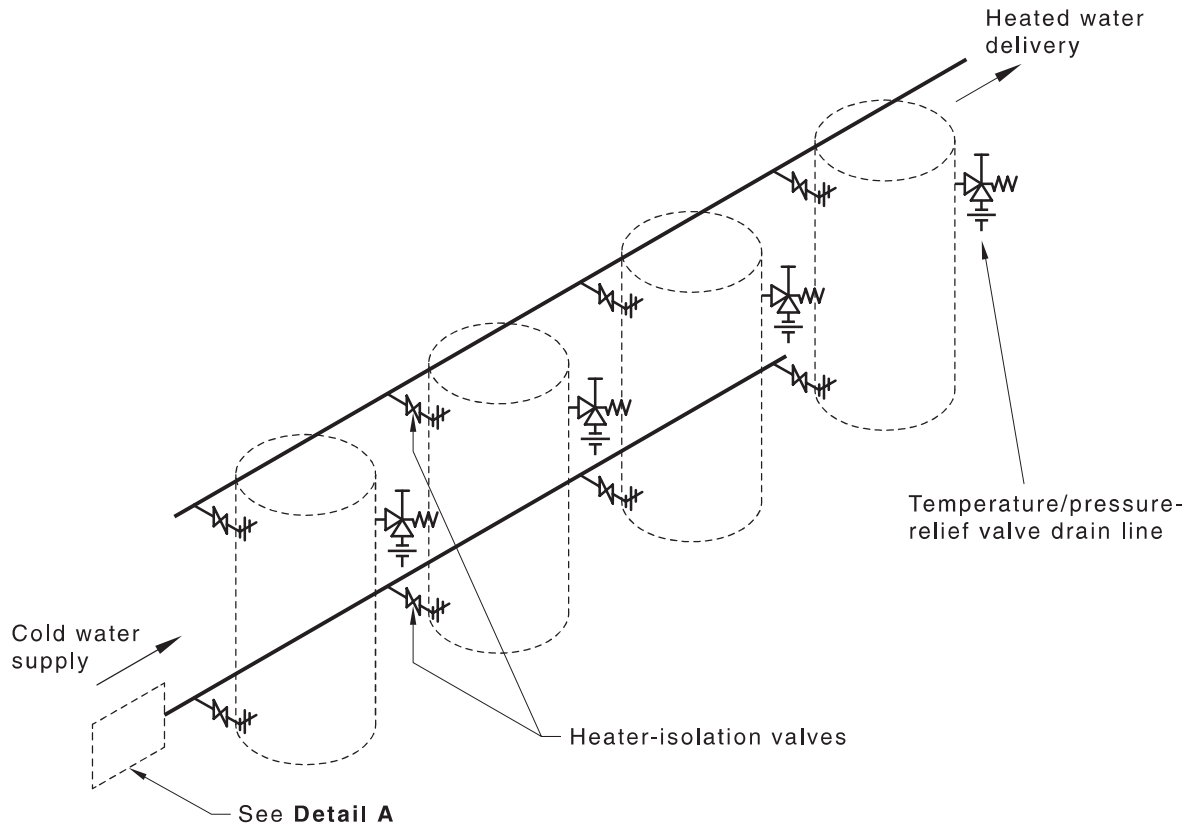
- (a) The water heaters shall be of the same storage capacity and energy input capacity, with the same nominal temperature setting and be connected in parallel.
- (b) The cold water service to the inlet header shall enter the bank from the opposite end to that from which the heated water service leaves the outlet header.

NOTE See [Figures 5.10.2\(A\)](#) and [5.10.2\(B\)](#) for typical arrangements.

- (c) The heated water return in a recirculation system shall connect to the cold water header and enter the bank from the opposite end to that from which the heated water service leaves the outlet header.
- (d) Inlet and outlet headers shall be of the same nominal size and length and the same shape with identical connections. The size of the headers shall be either the nominal size or the minimum size, as given in [Table 5.10.2](#), whichever is the larger.
- (e) All inlet branch pipes shall be of the same nominal size and be of the same length and shape.
- (f) All outlet branch pipes shall be of the same nominal size and be of the same length and shape.
- (g) Where a hot water return header is installed, all return branch pipes shall be of the same nominal size and be of the same length and shape, i.e. balanced.
- (h) Heater-isolation valves shall be fitted to inlet, outlet and return branch pipes. These valves shall be full-way gate valves or ball valves and be of the same nominal size as the pipe to which they are fitted.
- (i) Off-takes shall not be connected to any branch pipe or any intermediate part of the headers.

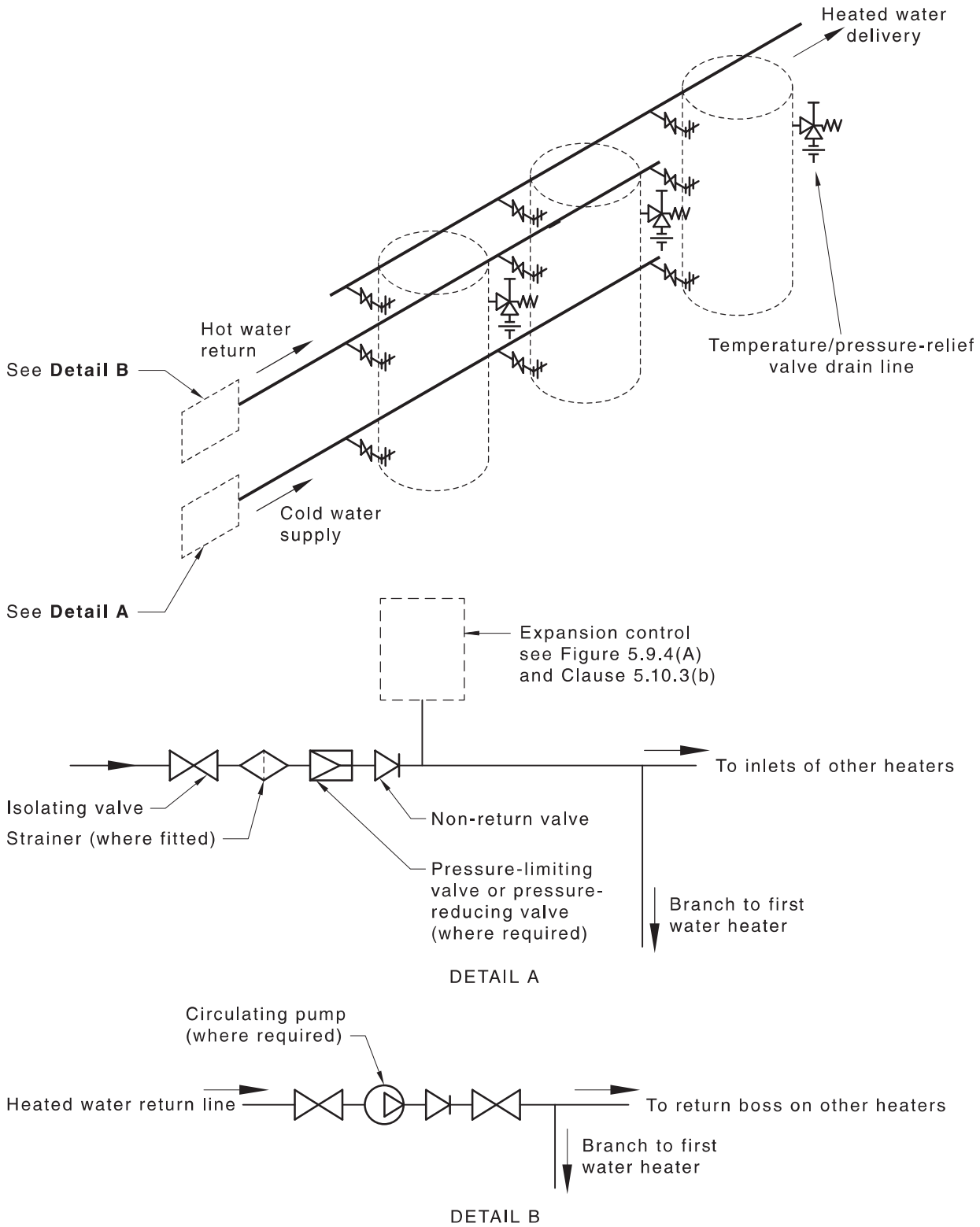
**Table 5.10.2 — Header sizes for multiple installations**

Number of heaters in bank	Nominal size of headers	Minimum size of headers DN
2	Same pipe size as branch pipes	20
3–5	One pipe size larger than branch pipes	25
6–10	Two pipe sizes larger than branch pipes	32
11–15	Three pipe sizes larger than branch pipes	40



DETAIL A

**Figure 5.10.2(A) — Typical in-line arrangement of multiple storage water heaters**



**Figure 5.10.2(B) — Typical alternative arrangement of heated water return line for circulating heated water service**

### 5.10.3 Location and sizing of control valves and expansion vessels on the cold water supply

Where fitted, control valves and expansion vessels installed for water heaters in a multiple configuration shall meet the following requirements:

- (a) *Inlet-pressure-control valves* — Inlet-pressure-control valves shall be installed between the cold water supply isolating valve and the branch to the first water heater. Where two or more inlet-pressure-control valves are fitted in parallel, they shall be of the same pressure setting.
- (b) *Cold water expansion control valves and expansion vessels* — One or more expansion control valves or expansion vessels shall be installed immediately after the cold water isolation valve and the non-return valve, and pressure-reducing or pressure-limiting valve assembly to each bank of heaters as follows:
  - (i) The total kilowatt rating of the expansion control valves shall be not less than the total kilowatt rating of all the heaters in the bank.
  - (ii) The expansion vessel shall have a capacity at least twice the thermal expansion of the total volume of water in the system for the greatest temperature rise, being the difference between the coldest temperature in the pipework (i.e. during installation of the system, or when the system is not in operation) and the highest temperature during operation.
  - (iii) The expansion vessel shall be set to maintain a pressure within the system that is between the inlet pressure after any pressure-reducing/limiting valves and 85 % of the pressure relief valve setting.
  - (iv) The expansion vessel shall be designed for the maximum operating temperature of the system.

The thermal expansion volume and the sizing of expansion vessels shall be determined in accordance with [Appendix P](#).

## 5.11 Temperature/pressure-relief valve and expansion control valve drain lines

### 5.11.1 Size and material

For other than the expansion control valve fitted to heat exchange water heaters, every temperature/pressure-relief valve and expansion control valve shall be fitted with a drain line that meets the following requirements —

- (a) be of a diameter not smaller than the nominal size of the valve outlet;
- (b) have a length in accordance with [Table 5.11.1](#); and
- (c) be of copper piping.

NOTE It may be necessary to have the valve drain line discharge into a tundish when the distance to the point of final discharge is greater than the maximum given in the table.

**Table 5.11.1 — Lengths and changes of direction**

Maximum relief drain length m	Maximum numbers of changes of direction (greater than 45°)
9	3
8	4
7	5
6	6

## 5.11.2 Interconnection of drain lines

### 5.11.2.1 Individual water heaters

The drain lines from the outlet of the temperature/pressure-relief valve and the expansion control valve on an individual water heater may be joined together subject to the following:

- (a) Interconnection is limited to the drain lines from the outlets of one temperature/pressure-relief valve and one expansion control valve, see [Clauses 5.8\(c\)](#) and [5.10.3\(b\)](#).
- (b) Installation of the drain lines conforms with [Clause 5.11.3](#).

NOTE Some regulatory authorities may not permit interconnection of drain lines.

### 5.11.2.2 Multiple relief valves

Except for drain lines conforming with [Clause 5.11.2.1](#), the drain lines from multiple relief valves shall not be interconnected. Where multiple relief valves discharge over a tundish on a common drain line, the common drain line shall be sized in accordance with [Clause 5.11.5](#).

### 5.11.3 Installation

Drain lines from temperature/pressure-relief valves, expansion control valves and tundishes shall be installed as follows:

- (a) There shall be no tap, valve or other restrictions in any line.
- (b) Each line shall fall continuously from the valve to the point of discharge.
- (c) Drain lines from expansion control or temperature/pressure-relief valves shall not discharge into a safe tray.
- (d) The point of discharge from each drain line shall be located so that the release of steam or hot water does not cause a nuisance, is readily discernible and incurs no risk of damage to the building or injury to persons.
- (e) Where a drain line terminates outside a building, the end of the line shall be —
  - (i) not lower than 75 mm or higher than 300 mm above an overflow relief gully or disconnector gully;
  - (ii) not lower than 75 mm or higher than 300 mm above a gravel pit not less than 100 mm in diameter;
  - (iii) over a tundish in accordance with Item (h) below; or
  - (iv) not lower than 200 mm or higher than 300 mm above an unpaved surface.

NOTE Where discharges from valves may adversely affect slabs and footings of buildings, the drain lines should discharge away from the building. Further guidance is provided in the National Construction Code (NCC).

- (f) Where the drain line from the expansion control valve on a heat exchange water heater is directed into the water storage container, there shall be a minimum air gap of 20 mm, except where the valve and associated drain lines are supplied as an integral part of the water heater.
- (g) Where a water heater is externally located, the drain line from the relief valve shall be terminated so as to discharge water away from the operator during operation of the valve.
- (h) Where discharging over a tundish or gully, drain lines shall have an air gap of a size at least twice the diameter of the drain line.

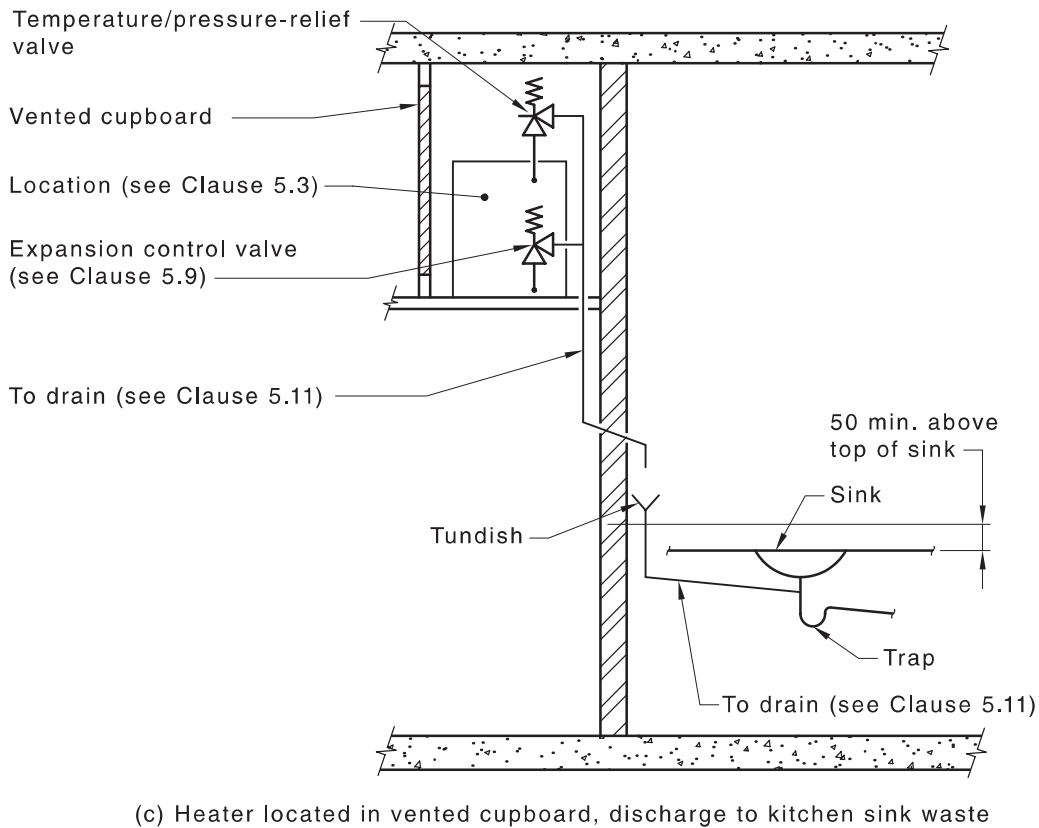
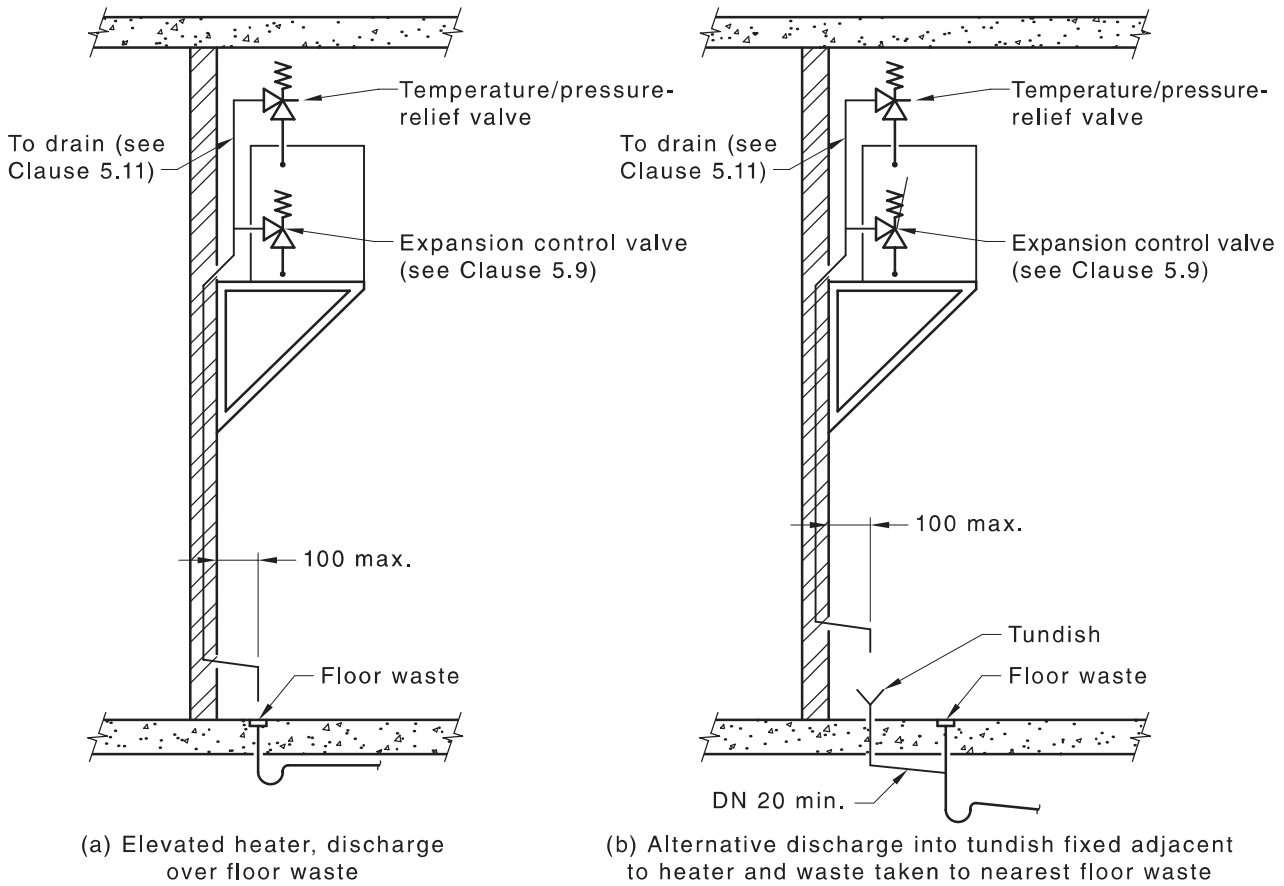
- (i) Where installed, plastics drain lines shall be —
- (i) continuously supported;
  - (ii) fixed and secured in accordance with [Clause 4.5](#);
  - (iii) protected from UV if exposed to direct sunlight; and
  - (iv) installed with a suitable allowance for thermal movement.

NOTE 1 Typical installations of drain lines are illustrated in [Figures 5.11.3\(A\)](#) and [5.11.3\(B\)](#).

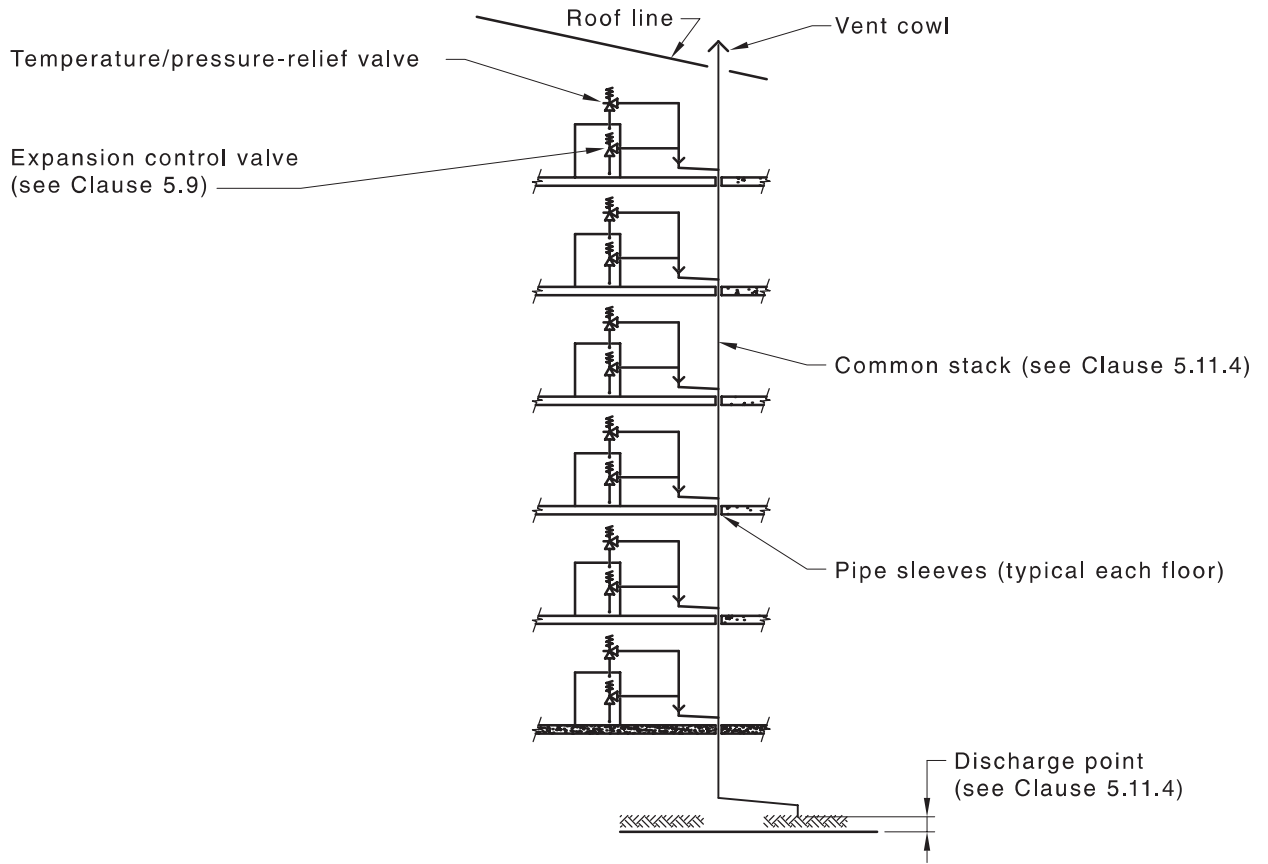
NOTE 2 Ponding should be avoided.

NOTE 3 As the function of the temperature/pressure-relief valve on the water heater is to discharge high temperature water under certain conditions, the pipework downstream of the relief valve should be capable of carrying water exceeding 93 °C. Failure to observe this precaution may result in damage to pipework and property.

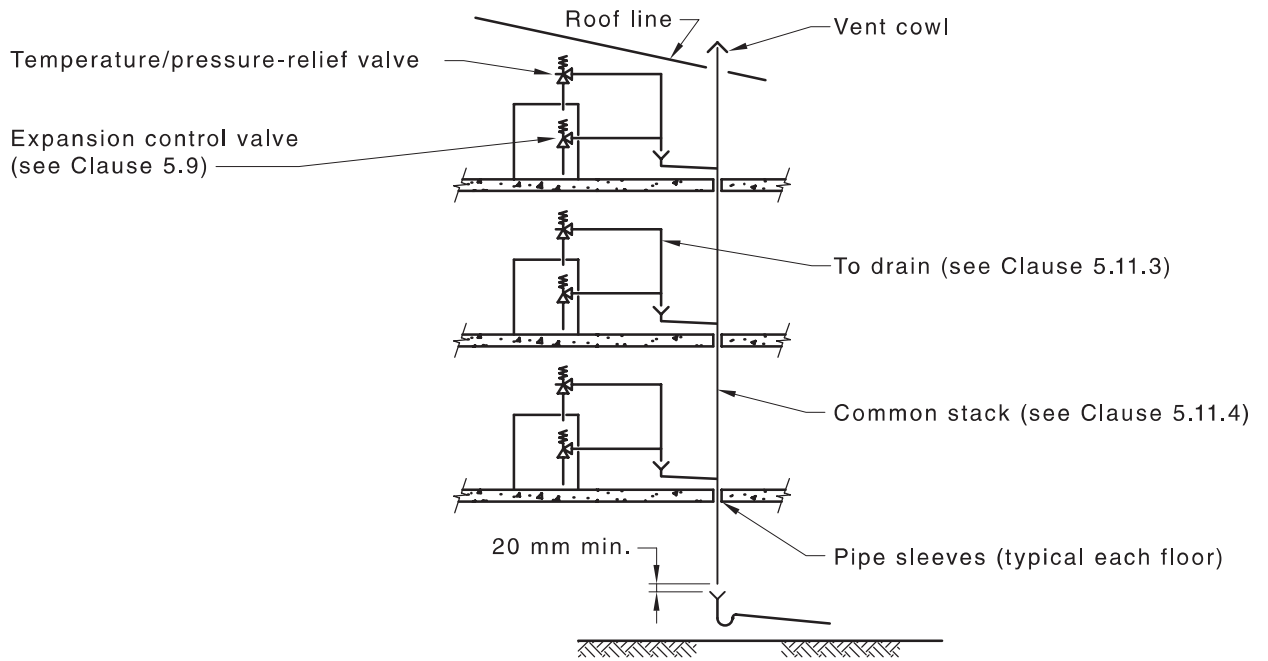
Dimensions in millimetres



**Figure 5.11.3(A) — Typical relief drainage**



(a) Common stack discharge over ground, stormwater drain or gully



(b) Common stack discharge to a soil or waste stack

**Figure 5.11.3(B) — Typical temperature/pressure-relief valve drain lines — Common stack discharge methods**

#### 5.11.4 Common stack discharge

Where individual water heaters are installed in a multi-storey building, the relief drain lines may discharge into a common stack, provided the following criteria are met:

- (a) The discharge from the common stack is to a tundish, having a discharge line that is not less than the size of the common stack, directly connected to a fixture trap, and installed in connection with any adjacent soil or waste stack.
- (b) The discharge point of the common stack is such that any discharge is readily visible and does not cause any nuisance.
- (c) The common stack is vented by extending the pipe upwards, above the roof level.

NOTE The recommended minimum size of a common stack is DN 40.

#### 5.11.5 Tundish drain lines

The drain line from any tundish shall be not less than one size larger than that of the largest drain line discharging into the tundish. Tundish drain lines shall conform to [Clause 5.11.3](#).

#### 5.11.6 Areas subject to freezing

In areas where water pipes are prone to freezing, the drain line from any valve shall be insulated and not exceed 300 mm in length. It shall discharge into a tundish through an air gap of not less than 75 mm and not more than 150 mm measured from the outlet of the drain line to the rim of the tundish.

### 5.12 Vent pipes

#### 5.12.1 Installation

##### 5.12.1.1 Storage water heaters

Each vented storage water heater shall be fitted with a vent pipe of copper not smaller than DN 20 and —

- (a) have no tap, valve, sharp change of direction or other restrictions in the pipe;
- (b) rise continuously from the point of connection; and
- (c) have any roof or wall penetration rendered waterproof with due allowance made for expansion.

##### 5.12.1.2 Heat exchange water heaters and boiling water units

Where required, vent pipes shall be installed for heat exchange type water heaters and boiling water units.

NOTE The venting requirements for heat exchange type water heaters and boiling water units may be product specific.

#### 5.12.2 Termination of vent pipe

Vent pipes installed on a water heater shall —

- (a) when over a cold water storage tank, be turned downward and discharge into the cold water storage tank by passing through the lid, finishing not lower than the outlet of the float valve and not discharging over the float valve assembly;
- (b) when taken through a roof, have the open end of the pipe point upwards or be turned downwards and if projecting more than 1 m above the roof, be supported; and

NOTE For a typical treatment, see [Figure 5.9.4\(D\)\(b\)](#).

- (c) in locations subject to freezing conditions, vent pipes shall be insulated to at least 300 mm above the working water level.

### 5.12.3 Cold water storage tank-fed water heaters (other than side-fed types)

When fitted in conjunction with a cold water storage tank, vent pipes shall rise to a height not less than 80 mm above the static water level in the tank for every 1 m between the overflow water level in the feed tank and the base of the heater, or 300 mm, whichever is the greater.

### 5.12.4 Vented storage water heaters, inlet pressure-controlled

When installed in conjunction with a water heater fitted with a pressure-reducing valve, a vent pipe shall rise to a height above the outlet of the pressure-reducing valve in accordance with [Table 5.12.4](#), and be in accordance with [Equation 5.12.4](#):

$$H = \frac{SP}{10} + 1 \quad 5.12.4$$

where

$H$  = height of vent pipe, in metres, to the nearest 0.5 m

$SP$  = set outlet pressure of the reducing valve, in kilopascals

**Table 5.12.4 — Height for vent pipes above a pressure-reducing valve**

Pressure-reducing valve setting kPa	Height of vent pipe m
25	3.5
30	4.0
35	4.5
45	5.5
50	6.0
70	8.0

## Section 6 Installation of solar water heaters

### 6.1 Scope of section

This section covers the installation of solar water heating systems with fixed orientation and inclination used either in single-unit or in multiple-unit installations. It is applicable to the following types of solar heated water systems which include collectors with either flat plate or evacuated tube absorbers:

- (a) Systems with the solar collector remote from the heated water container, with both components supplied as a complementary and packaged system and with primary circuit piping arranged to suit site conditions.
- (b) Custom-built systems where the solar collector is connected to an existing remote heated water container or new container, not sold packaged with the collector, and with primary circuit piping arranged to suit site conditions.
- (c) Close-coupled or integral solar water heaters.

### 6.2 Application of section (New Zealand only)

For the installation of solar water heaters in New Zealand refer to NZBC Acceptable Solution G12/AS2 Solar Water Heaters.

### 6.3 General installation requirements

#### 6.3.1 Sizing and solar performance

The performance of particular system configurations and installations, particularly packaged systems, shall be determined using the methods given in AS/NZS 4234.

NOTE 1 In Australia, energy efficiency requirements for water heaters are contained in the National Construction Code Volume Three, Plumbing Code of Australia.

NOTE 2 See [Appendix E](#) for recommendations for the installation of unrated solar heated water supply systems.

NOTE 3 The ratio of container volume to collector area should be in the range of 40 L to 90 L per square metre of collector area.

NOTE 4 Collector area and container size will affect system performance.

#### 6.3.2 Location

The components of the system shall be located so as to maximize solar gain and minimize energy losses. They shall be positioned to facilitate maintenance and the choice of a suitable route for piping between the container and the collector.

NOTE 1 See [Clause 5.3.1](#) for placement of water heaters.

NOTE 2 See [Appendix F](#) for recommendations on the installation of close-coupled and integral solar heated water systems on roofs.

NOTE 3 See [Appendix G](#) for suggested component sizes.

NOTE 4 See [Appendix I](#) for information on the effect of inclination and orientation on system performance.

***C6.3.2 Environmental factors of solar radiation for the area, local consideration of dust, hail, frost, shade and wind, and the aspects of both the quality of water used and the consumer habits, with regard to heated water usage, will affect both the performance and the service life of the unit. Performance will also be affected by storage container size and time of day when supplementary heating is applied.***

*(continued)*

*Where geographical locations are less than ideal, improved performance of a system may be achieved by the installation of either an additional collector(s) or higher performing collectors.*

### 6.3.3 Structural integrity

The collective weight of collector(s), any associated filled container and their mounting frames shall not exceed the loading prescribed for the roof.

Where systems are supported on roof battens crossing rafters or trusses the battens shall be continuous across not less than three rafters or trusses.

NOTE 1 Mounting frames, support rails or brackets that are used to support and/or orientate a roof-mounted system or system components should be supported on rafters or trusses spaced at a maximum of 1200 mm centres.

NOTE 2 Where mounting frames are used for orientation and connection to the roof structure, the mounting frame and its attachments should be suitable for local wind conditions, particularly in cyclonic regions where local advice should be sought.

NOTE 3 See [Appendix J](#) for a map of regional basic design wind speeds.

NOTE 4 Verification of frames or components as to their structural suitability may be required by the regulatory authority.

NOTE 5 The weight of the container and collector full of water should be considered in the design of the roof structure and supports.

NOTE 6 Installation of a container on an existing roof will require that the roof structure is adequate for the load of the container and collector. Where the roof is considered to have inadequate strength to support the container and collector, the roof structure will need to be strengthened prior to installation.

NOTE 7 In Australia, supporting battens and their fixing to each rafter or truss should be in accordance with the requirements of the NCC.

### 6.3.4 Water hardness and dissolved solids

Where the Saturation Index (SI) of the water exceeds +0.4, collectors shall not be charged with water unless they are covered by an opaque material until required for use.

NOTE Water supplies with high total dissolved solids content may have a detrimental effect on some collectors. Advice should be sought from the manufacturer as to the suitability of a particular product intended to be used with water of high total dissolved solids (generally in excess of 500 mg/L).

### 6.3.5 Collector circuit

The collector circuit shall utilize a direct system or indirect system.

NOTE Refer to AS/NZS 3500.0 for relevant definitions for solar heated water systems.

### 6.3.6 Flow and return pipes and fittings

Piping used between the collector and the container shall be a minimum of DN 15 copper or stainless steel.

Plastics pipes and fittings shall not be used between the collector and the container except as specified in [Clause 2.5.2\(e\)](#).

Thermal insulation shall be in accordance with [Section 8](#).

### 6.3.7 Corrosion resistance

All materials shall conform to the following:

- (a) Materials that are jointed directly to, or in contact with, other materials shall have chemical and galvanic compatibility with those materials to prevent corrosion or other deterioration that would impair their function during their intended service life.
- (b) All brackets, fixing straps, support rails, mounting frames and fixings used for the external installation of solar water heaters and their components shall be manufactured from hot dip galvanized mild steel, grades 304, 316 or 430 stainless steel or a material of equivalent strength and corrosion resistance.
- (c) Where components are fabricated from welded mild steel, they shall be hot dip galvanized after fabrication.
- (d) Containers installed externally shall conform to [Clause 5.6](#).

### 6.3.8 Entrapped air

All piping shall be installed to eliminate air from the heat transfer fluid circuit.

NOTE 1 For thermosiphon systems, this may be achieved if the pipes connecting the collector and the storage container rise continuously from the collector to the storage container.

NOTE 2 In a thermosiphon system, the circulation pipe from the top of the collectors to the entry point in the container should have an average upward slope of not less than 1 in 7. The minimum upward slope at any point should be not less than 1 in 20, unless the pipe is vented at that point.

### 6.3.9 Over-temperature protection

Custom-built systems that include a controlled supplementary heater shall be fitted with an over-temperature protection device.

NOTE Refer to AS/NZS 2712 for information on solar and heat pump water heaters.

### 6.3.10 Pressure and temperature relief

Relief valves shall have a relief capacity not less than the total output power of the collectors at 99 °C and 1 100 W/m<sup>2</sup> and 50 °C effective ambient plus that of any supplementary heater.

NOTE 1 The design of the system should be such that the temperature of the water in the container does not activate any supplementary energy safety cut-outs under normal conditions of operation.

NOTE 2 Refer to AS/NZS 2712 for information on solar and heat pump water heaters.

### 6.3.11 Drain lines

Drain lines for temperature/pressure-relief and expansion control valves shall be installed in accordance with [Clause 5.11](#).

Copper pipe used for drain lines crossing a metal roof shall be fully insulated with UV resistant weatherproof lagging to prevent corrosion of the metal surface.

### 6.3.12 Unintentional circulation

The plumbing installation shall be designed to —

- (a) minimize unintentional circulation of heated water through the collector;
- (b) prevent reverse thermosiphoning from containers with electrical or gas heating; and

- (c) prevent thermosiphon circulation from wetbacks to the collectors.

NOTE This may be achieved through the use of —

- (a) a heat trap in accordance with [Clause 8.4](#) Items (a) and (b); or  
 (b) a non-return valve.

### 6.3.13 Mounting

Rails or angles used for the support of collectors, containers or mounting frames shall be installed across the slope of the roof and fixed through the upper profile of the roof sheeting into the supporting battens.

Support rails used on tiled roofs shall be securely fixed to fixing straps. Fixing straps that are used to restrain collectors and/or containers on tiled roofs shall pass beneath the tiles and be securely fixed directly to the rafters or trusses with a minimum of three screws 40 mm long per fixing strap.

NOTE A reference to tiles and tiled roofs in this section is a reference to cement, terracotta or other composite tiles.

### 6.3.14 Supplementary heating

Supplementary heating equipment shall be provided and have thermal capacity to supply heated water requirements.

NOTE Refer to AS/NZS 2712 for information on solar and heat pump water heaters.

### 6.3.15 Penetrations through roof cladding

Penetrations through the roof cladding of structural supports, fixings, pipes and wiring shall be —

- (a) through the upper profile of roof tiling or through the upper rib of metal sheeting;  
 (b) flashed or sealed around the penetrating member using purpose made sealing washers or boots, with allowance made for thermal expansion; and  
 (c) installed in a manner that will not prevent rainwater flow across the roof, trap debris or cause ponding.

All metal swarf shall be removed from the roof and guttering on completion of the installation.

## 6.4 Installation of solar water heater storage containers

### 6.4.1 General

Storage containers for solar water heaters shall be located in accordance with [Clause 5.3](#) and be installed in accordance with the relevant requirements of [Clauses 5.4](#) to [5.12](#).

### 6.4.2 Thermosiphon systems

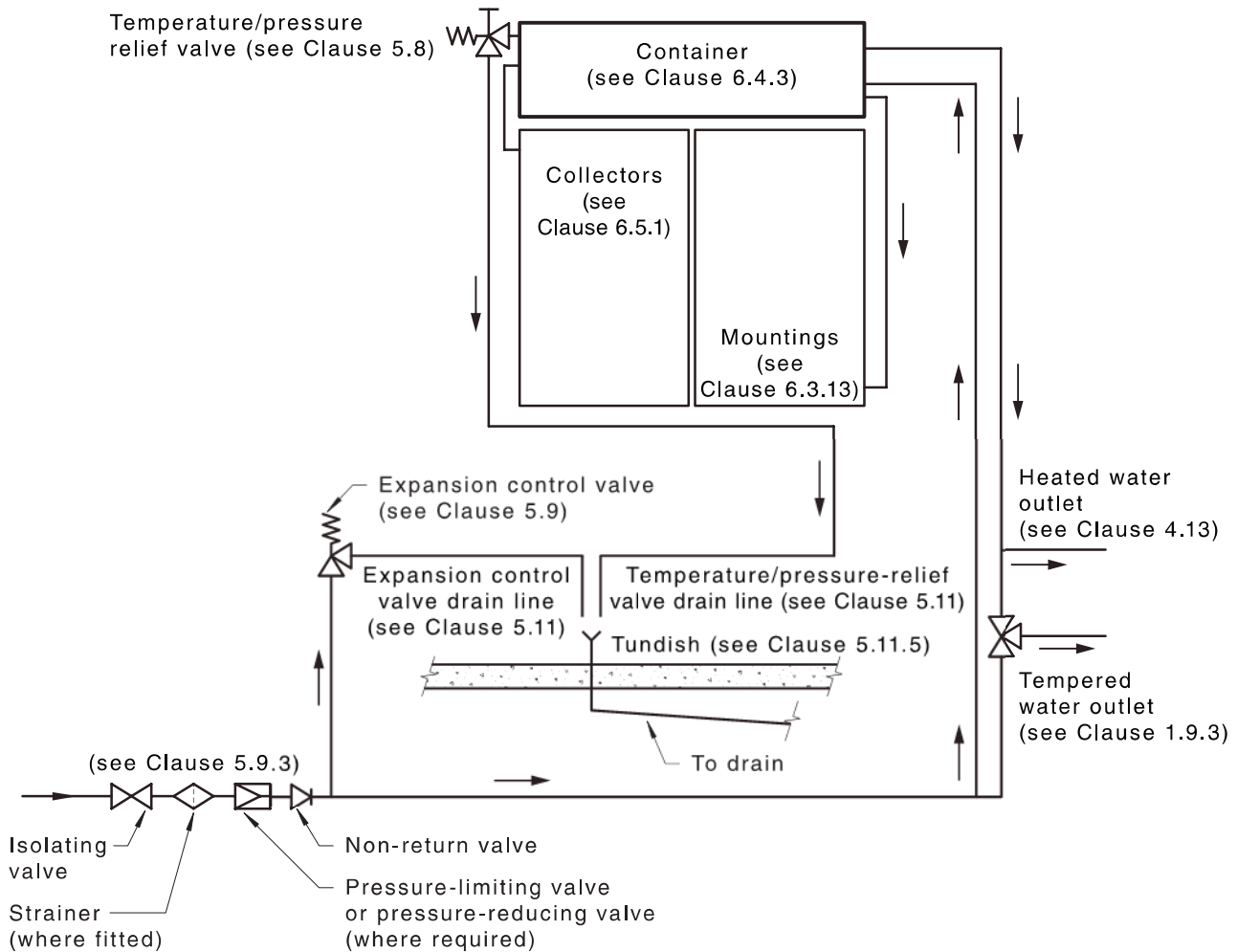
For thermosiphon systems where the collector is remote from the container, the top of the collectors shall be not less than 150 mm (measured vertically) below the bottom of the container.

### 6.4.3 Support

Containers of close-coupled or integral systems mounted directly onto or above a roof structure shall be supported in accordance with [Clause 6.3](#).

NOTE See [Figure 6.4.3](#) for a typical installation of a close-coupled solar water heater.

Containers located remotely from the collectors and those located in roof spaces shall be supported in accordance with [Clause 5.5](#).



**Figure 6.4.3 — Typical installation of close-coupled solar water heater**

#### 6.4.4 Safe trays

Where containers are installed in roof spaces, cupboards, or are otherwise concealed, they shall be placed on a safe tray in accordance with [Clause 5.4](#).

#### 6.4.5 Auxiliary water heating

A solar water heater provided with auxiliary water heating shall conform to the following:

- (a) Only connection points in the container or in fittings or components intended for this purpose shall be used.
- (b) The temperature/pressure-relief valve or expansion control valve shall conform to [Clause 5.9](#).
- (c) The installation of auxiliary heating by uncontrolled heat sources shall conform to [Clause 7.2](#).
- (d) For systems with remote containers, an auxiliary heating connection shall not be made to the primary circuit flow and return lines.

## 6.5 Installation of collectors

### 6.5.1 Positioning

#### 6.5.1.1 Shade

Collectors shall be located so that they are clear of shade for not less than 3 h either side of solar noon at any time during the year. Partial shading by small objects, such as chimneys, flues and TV antennas, is permissible during this period.

NOTE 1 Nominal times to be clear of shade would be between 9 am and 3 pm standard time.

NOTE 2 See [Appendix H](#) for information on estimation of shading of collectors.

#### 6.5.1.2 Commercial solar collector orientation

In Class 2 to Class 9 buildings, collectors shall be installed so that they face no greater than 45° east or west of true north.

#### 6.5.1.3 Residential solar collector orientation

In Class 1 and Class 10 buildings, collectors shall be installed so that —

- (a) They face no greater than 45° east or west of true north; or
- (b) The solar water heater achieves an energy saving, as determined in accordance with AS/NZS 4234, of not less than 40 % for a “small” load system for a dwelling with one or two bedrooms or 60 % for a “medium” load system for a dwelling with three or more bedrooms. These requirements shall be deemed to be satisfied when collectors are installed so they face greater than 45° and up to 90° east or west of true north and the solar water heater achieves —
  - (i) the minimum listed number of Small-scale Technology Certificates (STCs) listed in [Table 6.5.1.3\(A\)](#); or
  - (ii) the minimum energy savings listed in [Table 6.5.1.3\(B\)](#).

NOTE 1 A Small-scale Technology Certificate (STC) is a certificate created under the Renewable Energy (Electricity) Act 2000. As a guide, one STC is equal to one Megawatt hour of eligible renewable electricity either generated or displaced by a renewable energy system. STC values for registered solar water heaters can be obtained from the Clean Energy Regulator (CER).

NOTE 2 In general, better performance will be achieved the closer the collectors are placed to true north.

NOTE 3 True north should not be confused with a compass reading of magnetic north. The difference between true north and magnetic north is known as magnetic declination. Where a magnetic compass is used, it is important to adjust for magnetic declination from true north.

NOTE 4 Examples of magnetic declination adjustments are given in [Table 6.5.1.3\(C\)](#).

NOTE 5 Load sizes are as specified in AS/NZS 4234.

NOTE 6 The minimum energy saving values listed in [Table 6.5.1.3\(B\)](#) are calculated using the Clean Energy Regulator (CER) methodology, which assumes that the solar collectors are installed at an orientation of 45° west of due north. The performance of a solar water heater diminishes at collector orientations greater than 45° east or west of true north and so the minimum values listed in the table (i.e. at an assumed orientation of 45°) have been increased to ensure that the solar water heater with collectors at the installed orientation will still achieve an energy saving of 40 % or 60 % as specified in [Clause 6.5.1.3\(b\)](#).

NOTE 7 [Table 6.5.1.3\(A\)](#) contains the STC values corresponding to the energy savings in [Table 6.5.1.3\(B\)](#).

NOTE 8 In Australia, buildings are classified by the NCC.

**Table 6.5.1.3(A) — Minimum listed number of Small-scale Technology Certificates**

Climate zone <sup>a</sup>	Orientation west from true north			Orientation east from true north		
	90° to > 75°	75° to > 60°	60° to > 45°	> 45° to 60°	> 60° to 75°	> 75° to 90°
<b>Zone 1</b>						
1 or 2 bedrooms	10	10	9	10	10	10
3 or more bedrooms	23	23	22	23	23	24
<b>Zone 2</b>						
1 or 2 bedrooms	10	10	9	10	10	10
3 or more bedrooms	23	23	22	23	24	24
<b>Zone 3</b>						
1 or 2 bedrooms	12	12	11	11	12	12
3 or more bedrooms	28	28	27	27	28	29
<b>Zone 4</b>						
1 or 2 bedrooms	13	13	12	13	13	14
3 or more bedrooms	31	30	29	30	31	32

<sup>a</sup> Climate zones are specified in [Figure 6.5.1.3](#).

NOTE 1 Small-scale Technology Certificate (STC) values for registered solar water heaters can be obtained from the Clean Energy Regulator (CER).

NOTE 2 Required at 45° west of true north (CER Calculation method) to provide minimum performance level at the installed orientation.

**Table 6.5.1.3(B) — Minimum energy (solar) savings at the installed orientation**

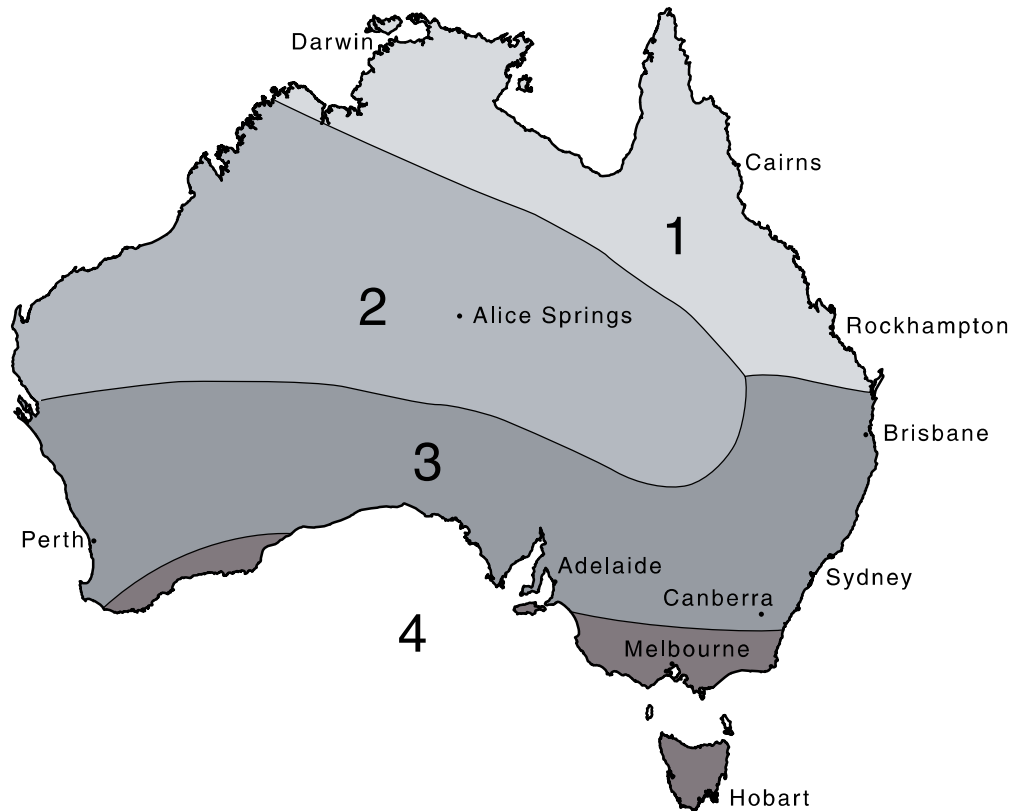
Climate zone <sup>a</sup> and load size <sup>b</sup>	Orientation west from true north			Orientation east from true north		
	90° to > 75°	75° to > 60°	60° to > 45°	> 45° to 60°	> 60° to 75°	> 75° to 90°
<b>Zone 1</b>						
Small load (1 or 2 bedrooms)	43 %	42 %	41 %	43 %	44 %	46 %
Medium load (3 or more bedrooms)	64 %	63 %	62 %	64 %	66 %	67 %
<b>Zone 2</b>						
Small load (1 or 2 bedrooms)	44 %	42 %	41 %	43 %	44 %	46 %
Medium load (3 or more bedrooms)	65 %	63 %	61 %	63 %	66 %	67 %
<b>Zone 3</b>						
Small load (1 or 2 bedrooms)	45 %	43 %	41 %	43 %	44 %	46 %
Medium load (3 or more bedrooms)	67 %	64 %	62 %	64 %	66 %	68 %
<b>Zone 4</b>						
Small load (1 or 2 bedrooms)	44 %	42 %	41 %	44 %	45 %	47 %
Medium load (3 or more bedrooms)	65 %	63 %	61 %	63 %	65 %	67 %

**Table 6.5.1.3(B)** *(continued)*

Climate zone <sup>a</sup> and load size <sup>b</sup>	Orientation west from true north			Orientation east from true north		
	90° to > 75°	75° to > 60°	60° to > 45°	> 45° to 60°	> 60° to 75°	> 75° to 90°
<p><sup>a</sup> Climate zones are specified in <a href="#">Figure 6.5.1.3</a>.</p> <p><sup>b</sup> If a solar water heater achieves the listed minimum solar saving for a larger load size, it may be deemed acceptable.</p> <p>NOTE Values have been calculated using the Clean Energy Regulator (CER) methodology, which assumes that the solar collectors are installed at an orientation of 45° west of due north.</p>						

**Table 6.5.1.3(C) — Examples of magnetic declination**

Location	Angle of declination <sup>a</sup>
Adelaide	8.1 East
Alice Springs	4.5 East
Auckland	19.3 East
Brisbane	10.6 East
Cairns	6.5 East
Canberra	12.2 East
Christchurch	23.3 East
Darwin	3.10 East
Hobart	14.5 East
Invercargill	25.1 East
Melbourne	11.3 East
Perth	1.4 West
Sydney	12.3 East
Wellington	22.1 East
<sup>a</sup> degrees east or west of magnetic north	



**Figure 6.5.1.3 — Australian climate zones**

#### 6.5.1.4 Inclination

Collectors shall be inclined at an angle within 20° of the local latitude angle.

For thermosiphon systems, the minimum inclination angle shall be 10°.

NOTE 1 The optimum inclination angle is the latitude of the site (for example, an inclination angle of 27° for the city of Brisbane would be optimum). However, inclination within 20° of the latitude angle will only reduce efficiency minimally. Inclination between 10° and 45° from the horizontal is generally suitable, depending on site location.

NOTE 2 Improved winter performance may be obtained by an angle of inclination greater than the latitude angle while improved summer performance is obtained from an angle of inclination less than the latitude angle.

NOTE 3 Examples of local latitudes of major cities are given in [Table 6.5.1.4](#).

NOTE 4 See [Appendix I](#) for data on the effect of changes in orientation and inclination on system performance.

**Table 6.5.1.4 — Examples of location latitudes**

Location	Latitude, degrees
Darwin	12
Brisbane	27
Perth	32
Sydney	34
Adelaide	35
Canberra	35
Auckland	37

**Table 6.5.1.4** (continued)

Location	Latitude, degrees
Melbourne	38
Devonport	41
Wellington	41
Hobart	43
Christchurch	43.5
Invercargill	46

### 6.5.1.5 Provision for removal of collector

Collectors shall be installed with fittings that will enable their removal without disturbing adjacent piping or collectors.

## 6.5.2 Precautions

### 6.5.2.1 Avoidance of damage

The collector shall be securely covered with an opaque material during installation and commissioning to prevent solar gain and to avoid collector damage or burn hazards.

### 6.5.2.2 Frost-prone areas

Collectors used in frost-prone areas shall be frost level 1, frost level 2 or protected by a frost protection system or device.

NOTE Refer to AS/NZS 2712 for information on solar and heat pump water heaters.

### 6.5.2.3 Hail-prone areas

In areas where hailstones in excess of 15 mm diameter are experienced, collectors shall be —

- (a) impact resistant; or
- (b) fitted with suitable impact guards.

NOTE 1 Refer to AS/NZS 2712 for information on solar and heat pump water heaters.

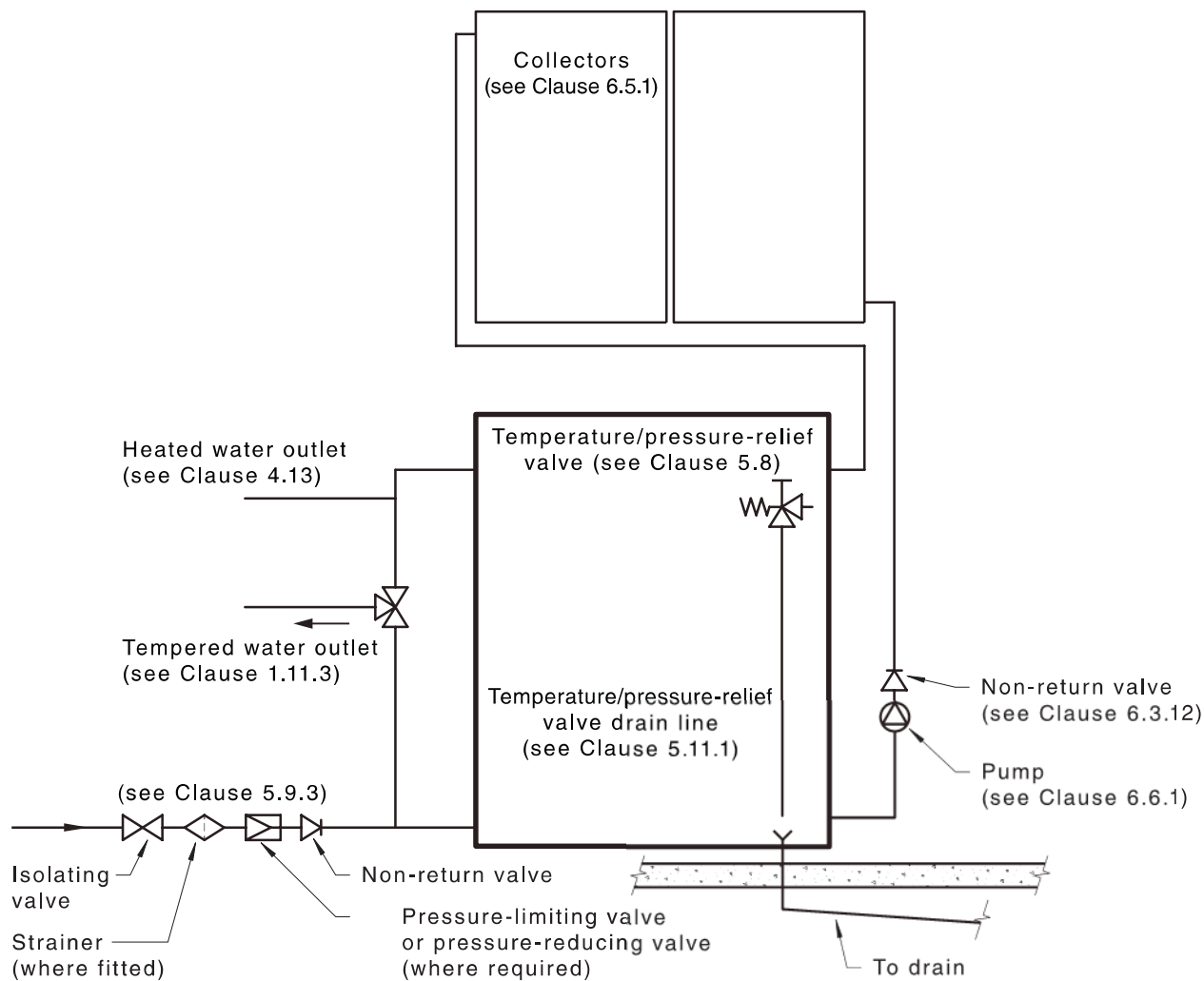
NOTE 2 Refer to AS/NZS 2712 for information on impact resistance.

## 6.6 Solar water heaters with remote containers

### 6.6.1 Pumps and controllers

Where circulating pumps and controllers are not supplied as an integral part of a packaged system, they shall be installed in accordance with [Clause 6.6.2](#).

NOTE A typical installation is shown in [Figure 6.6.1](#).



**Figure 6.6.1 — Typical installation of a solar water heater with remote container and forced circulation**

### 6.6.2 Pump and controller installation

The pump and controller installation shall conform to the following requirements:

- The primary circulating pump shall be installed to draw the colder water from the lower section of the container and to circulate this water through the collectors and return the heated water to the container at a point higher than the draw-off point.
- For packaged systems, only connection points in the container, or in fittings or components supplied with the system, shall be used for the cold water supply from the container and hot water return to the container.
- The pump shall be fixed to the building structure or the container, or otherwise rigidly supported and the piping system arranged so that no perceptible vibration is transmitted to either the collector or the building.
- Pumps and pump controls shall be fitted and connected in an accessible location to facilitate removal for servicing and maintenance.
- If mounted outdoors, the pump and pump controls shall be resistant to or protected against the ingress of water and dust.

- (f) Where an exposed-gland pump is used inside a building, it shall be installed above a safe tray that drains to the outside of the building or suitable outfall in accordance with [Clause 5.4.4.3\(d\)](#).
- (g) Pump controllers shall be mounted in a position that enables any “pump running” indicator to be prominent.

NOTE 1 Where pumped circulation is part of a freeze protection mechanism, the pump should be connected to an uninterruptible electricity supply wherever possible.

NOTE 2 Valves that will allow routine maintenance to be performed without draining the container should be provided.

## Section 7 Uncontrolled heat sources

### 7.1 Scope of section

This section sets out requirements for heated water systems that use uncontrolled heat sources.

### 7.2 Water heaters with uncontrolled energy source

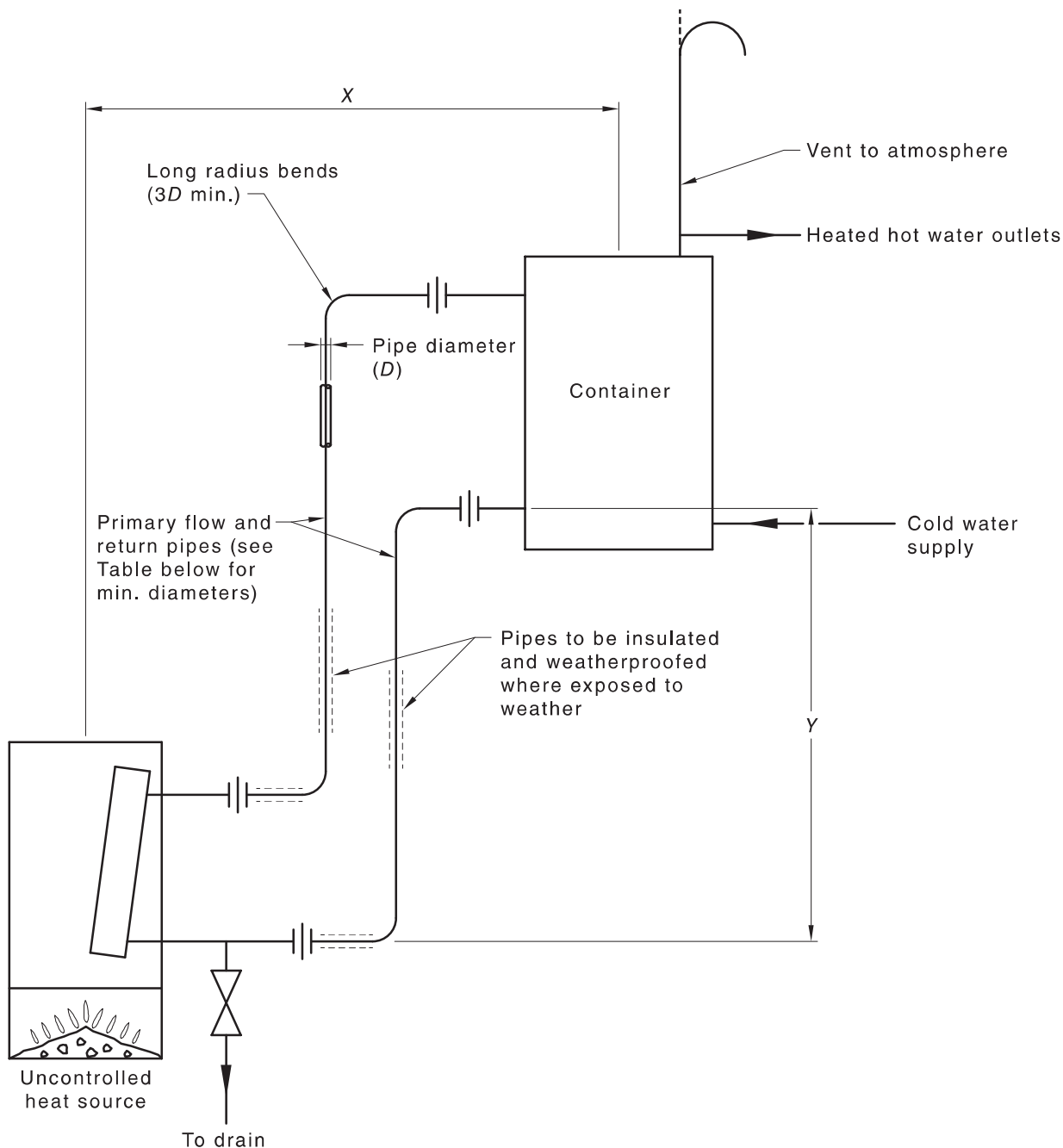
#### 7.2.1 Installation

The installation of water heaters with an uncontrolled heat input shall conform to the following:

- (a) Thermosiphon water heaters connected to slow combustion stoves or room heaters with water-heating coils, wetback boilers, or the like, shall —
  - (i) have no valves fitted or connected to the primary flow and return pipes between the water heater and the heat source;
  - (ii) have the primary flow and return pipes of a minimum nominal diameter relative to the length, as given in [Figure 7.2.1](#);
  - (iii) have the primary flow and return pipes rise or fall in a continuous gradient;
  - (iv) have the primary flow and return pipes insulated so as not to present a hazard and, where exposed to the weather, have the insulation waterproofed;
  - (v) have the primary flow and return pipes installed in accordance with [Figure 7.2.1](#);
  - (vi) have no dissimilar metals in the primary flow and return lines;
  - (vii) have no elbows fitted in or to the primary flow and return lines; and
  - (viii) have the flow and return line connections made only with unions or similar type couplings.
- (b) Thermosiphon water heaters specified in Item (a), and direct-fired water heaters, shall —
  - (i) be vented to atmosphere with a vent pipe in accordance with [Clause 5.12](#), as appropriate;
  - (ii) be installed so that the maximum working pressure measured at the base of the water container does not exceed 50 kPa; and
  - (iii) be fitted with a tempering valve.

NOTE 1 For the purpose of this clause, solar hot water systems fitted with a thermosiphon arrester, a heat dump valve, or a differential pump controller with a high limit cut-out are considered as having a controlled heat source.

NOTE 2 Installers should check with the manufacturer to ascertain if their equipment is compatible to be connected to a slow combustion stove/wetback boiler.



Y	Minimum nominal diameter, DN				
	X, m				
	2	4	6	8	10
1	20	20	25	32	32
2	20	20	25	32	32
3	20	20	20	25	32
4	18	20	20	25	25
5	18	20	20	20	25
6	18	18	20	20	25

NOTE Dimensions X and Y are true horizontal and vertical distances respectively.

Figure 7.2.1 — Pipe coordinates — Thermosiphon systems

### **7.2.2 Supplementary external heating**

Supplementary heating connection shall not be made into the primary circuit flow or return piping.

### **7.2.3 Provision for drainage**

A drain point to which a hose may be attached shall be provided at the system's lowest point.

## Section 8 Energy efficiency

### 8.1 Scope of section

This section specifies energy efficiency requirements for heated water installations.

In New Zealand, it applies to all systems supplying hot water to sanitary fixtures except where individual storage vessels exceed 700 L in capacity.

NOTE 1 This section does not apply to central heating systems.

NOTE 2 The provisions in this section are to assist in the reduction of greenhouse gas emissions by arranging heated water services to use energy efficiently.

NOTE 3 In Australia, refer to the NCC for requirements relating to water heaters.

NOTE 4 In New Zealand, this section may be used to demonstrate compliance with NZBC Clause H1 Energy Efficiency.

### 8.2 Thermal insulation

#### 8.2.1 Piping associated with storage water heaters

Piping shall be thermally insulated to achieve a minimum *R*-value as given in [Table 8.2.1](#) for the climate regions identified in [Appendix K](#) for Australia and [Appendix L](#) for New Zealand, as follows:

- (a) The inlet and outlet pipes, including valves, for a storage water heater, for at least the first 500 mm or, where an external heat trap is fitted, to a point 150 mm down the heat trap vertical leg closest to the water heater.
- (b) All relief valves fitted directly to a storage water heater.
- (c) The primary flow and return pipes, including valves, between an auxiliary heater and a storage water heater.
- (d) All vent pipes to 300 mm above the maximum operating water level of the heated water system.
- (e) On multiple installations, the whole heated water manifold, including valves, to a point at least 500 mm past the heated water outlet branch from the last water heater.
- (f) On a solar water heater installation, the pipework between a solar pre-heater and an in-line supplementary water heater.

The insulation installed in accordance with the above shall be installed so as not to impede the operation of the valves.

NOTE 1 Care should be taken to ensure the continuity of insulation at wall and roof penetrations. Insulation should be carried through roof penetrations into the ceiling area.

NOTE 2 In New Zealand, refer to NZBC Acceptable Solution H1/AS1 and NZS 4305.

NOTE 3 All exposed heated and cold water piping to and from externally mounted water heaters in frost-prone areas may require additional insulation to prevent freezing.

**Table 8.2.1 — Minimum thermal insulation — Piping associated with storage water heaters**

	Internal locations	External locations			
	All climate regions	Climate region A	Climate region B	Climate region C <sup>a</sup>	Climate region C alpine areas <sup>b</sup>
Pipe	0.3	0.3	0.6	0.6 <sup>c</sup>	1.0
Valve	0.2	0.2	0.2	0.2	0.2

<sup>a</sup> Where the length of the piping to or from the water heater is exposed in an external location for more than 1 m, the minimum thermal insulation in region C shall be  $R$  1.0.

<sup>b</sup> Alpine areas are areas in New South Wales, Australian Capital Territory and Victoria higher than 1 200 m above Australian Height Datum, and in Tasmania higher than 900 m above Australian Height Datum.

<sup>c</sup> Except alpine areas.

NOTE 1 An external location of a building is an unenclosed area and includes (a) an open sub-floor area of a building; and (b) the area of a building located under an open veranda or carport.

NOTE 2 The total  $R$ -values specified in this table may be achieved for most heated water piping materials by using the following insulation: (a) 9 mm of closed cell polymer,  $R = 0.2$ ; (b) 13 mm of closed cell polymer,  $R = 0.3$ ; (c) 25 mm of closed cell polymer,  $R = 0.6$ ; and (d) 38 mm of closed cell polymer,  $R = 1.0$ .

## 8.2.2 Other piping for heated water systems

Heated water system piping shall be thermally insulated in accordance with [Table 8.2.2](#) for the climate regions identified in [Appendix K](#) for Australia and [Appendix L](#) for New Zealand.

Where piping is required to be thermally insulated, valves in the line of pipe shall be insulated to a minimum total  $R$ -value of 0.2.

NOTE See [Table 8.2.1](#) Note 2(a).

**Table 8.2.2 — Minimum thermal insulation — Other heated water piping**

System	Location of piping to be insulated	Minimum total $R$ -values		
		Climate region A	Climate region B	Climate region C
Non-circulating heated water piping	All heated water piping that is buried or is within a conduit encased within a concrete floor slab	0.3	0.3	0.3
	All external piping from the water heater to the primary kitchen sink	0.3	0.6	1.0
	All external piping with trace heating including 500 mm along any branch off the trace-heated line	0.3	0.6	1.0
	All internal piping with trace heating, including 500 mm along any branch off the trace-heated line	0.3	0.3	0.3

**Table 8.2.2 (continued)**

System	Location of piping to be insulated	Minimum total <i>R</i> -values		
		Climate region A	Climate region B	Climate region C
Circulating heated water piping	All heated water piping that is buried or is within a conduit encased within a concrete floor slab (except for piping that is part of a floor heating system)	0.6	0.6	0.6
	All external flow and return piping, including 500 mm along any branch from the flow and return piping	0.6	0.6	1.0
	All internal flow and return piping, including 500 mm along any branch from the flow and return piping	0.6	0.6	0.6
	Along any dead leg branch serving an individual dwelling from flow and return piping where the flow piping is installed in common property	0.6	0.6	0.6
<p>NOTE 1 An external location of a building is an unenclosed area and includes (a) an open sub-floor area of a building; and (b) the area of a building located under an open veranda or carport, or the like.</p> <p>NOTE 2 The total <i>R</i>-values specified in this table may be achieved for most heated water piping materials by using the following insulation: (a) 13 mm of closed cell polymer, <i>R</i> = 0.3; (b) 25 mm of closed cell polymer, <i>R</i> = 0.6; and (c) 38 mm of closed cell polymer, <i>R</i> = 1.0.</p> <p>NOTE 3 Total <i>R</i>-values for insulation materials are calculated using (a) <i>R</i>-value: the thermal resistance (m<sup>2</sup>.K/W) of a component calculated by dividing its thickness by its thermal conductivity; or (b) Total <i>R</i>-value: the sum of the <i>R</i>-values of the individual component layers in a composite element including the air space and associated surface resistances.</p> <p>NOTE 4 Circulating heated water piping of solar water heating systems with remote containers shall have insulation with a minimum <i>R</i>-value of 0.3.</p> <p>NOTE 5 Thermosiphon solar water heating systems may not require insulation.</p>				

### 8.3 Protection of insulation

#### 8.3.1 Insulation exposed to the weather

Where insulation is exposed to the weather, it shall be of a weather-resistant type or surrounded by a weather-resistant enclosure.

#### 8.3.2 Protection of thermal insulation on buried piping

Thermal insulation on buried piping shall be protected as follows:

- (a) All absorptive insulation material shall be effectively protected against moisture penetration by an outer cover made of a durable waterproof material.
- (b) Where insulation is cut for joining purposes, the joint shall be wrapped with a durable inert waterproof tape.

### 8.4 Heat traps

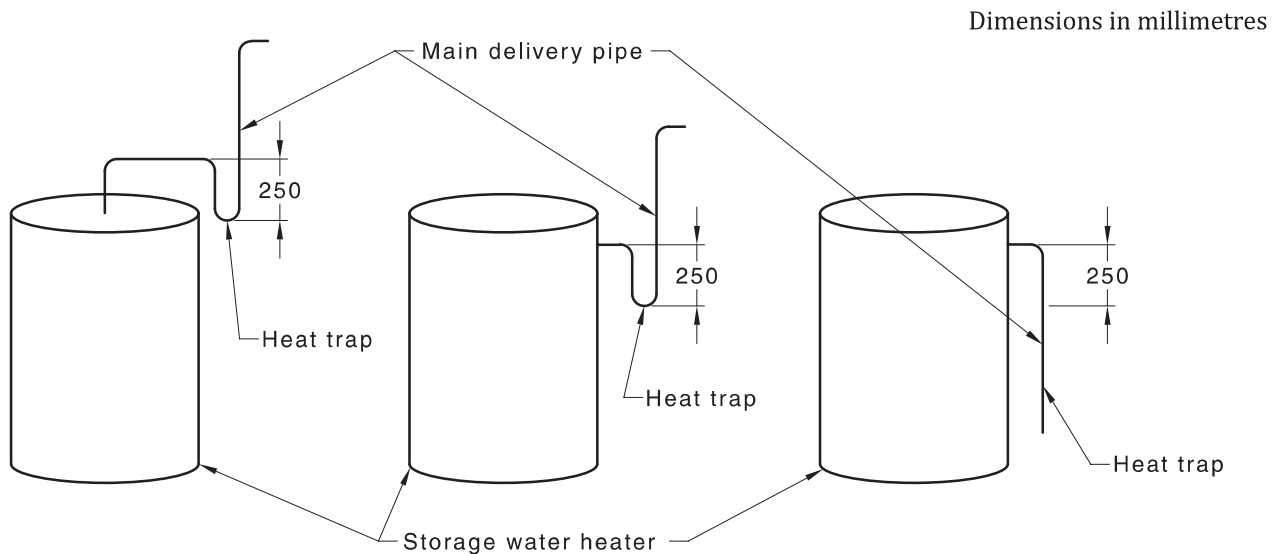
Heat traps shall be included in new and replacement non-circulatory installations as follows:

- (a) All storage water heaters shall have a heat trap within 1 m from the outlet of the water heater and before the first branch.

NOTE 1 See [Figure 8.4](#) for typical configurations.

- (b) The heat trap shall have a vertical drop of 250 mm from the outlet level of the storage water heater if the heat trap is not an integral part of the water heater.

NOTE 2 Where a heat trap is integral with the storage water heater and this is indicated by the permanent marking on the water heater, an external heat trap is not required.



NOTE Heat traps to be within 1 m from the outlet of unvented storage water heaters.

**Figure 8.4 — Typical configurations of external heat traps**

## 8.5 R-value calculations

The total  $R$ -value of a pipe fitted with a single layer of insulation may be calculated approximately as follows:

$$R = \frac{x_i}{k_i} + \frac{x_p}{k_p} \quad 8.5$$

where

- $R$  = total thermal resistance, in square metre kelvin per watt ( $\text{m}^2 \text{K/W}$ )
- $x_i$  = thickness of insulation, in metres (m)
- $k_i$  = thermal conductivity of insulation material, watt per metre kelvin ( $\text{W/m K}$ )
- $x_p$  = thickness of pipe wall, in metres (m)
- $k_p$  = thermal conductivity of pipe material, watt per metre kelvin ( $\text{W/m K}$ )

## Section 9 Testing and commissioning

### 9.1 Scope of section

This section specifies requirements for testing and commissioning a heated water service.

NOTE All fixtures, appliances, water tanks, storage water heaters and other equipment, which may be damaged during pressure testing, should be isolated before testing.

### 9.2 Flushing

Prior to hydrostatic testing, the piping system shall be cleaned and flushed to remove foreign matter. The flushing shall continue until the flushed water runs completely clear. After flushing, each line strainer shall be inspected and cleaned as necessary.

NOTE See [Clause 3.3](#) for special conditions for thermostatic mixing valves.

### 9.3 Testing

When all draw-off points are closed, those pipes that are subjected to pressure shall be hydrostatically tested in accordance with the following:

- (a) The completed heated water reticulation, excluding the storage container or water heater, shall not leak when tested with water at ambient temperature at a pressure of 1 500 kPa for a period of not less than 30 min. Prior to testing, the heating medium shall be isolated.

NOTE It may be necessary to disconnect fixtures, appliances and valves in order to prevent damage during testing.

- (b) Testing shall be carried out on all piping prior to being insulated or concealed in ducts, chases or trenches.
- (c) The complete system, including valves, pumps and other equipment, shall be tested under normal working conditions for a period of not less than 48 h. The system shall be checked visually for leaks.
- (d) All safe trays and safe wastes shall be tested with water to ensure that they do not leak under full flow conditions.
- (e) All drain pipes from expansion control and temperature/pressure-relief valves, air eliminator valves and all vent pipes shall be tested with water to ensure that they are unobstructed and are open to the atmosphere.

### 9.4 Commissioning

The heated water service shall be commissioned in accordance with the following:

- (a) Where an expansion vessel is fitted adjust the pre-charge pressure to equal the water supply pressure and each vessel shall be labelled with a water and fade resistant label affixed to the vessel, stating the pre-charge pressure.
- (b) The system shall be charged with water prior to the heating medium being applied to the heater.
- (c) All air shall be fully purged from the system.
- (d) The following items shall be checked for correct operation, as applicable:
  - (i) Leakage from each temperature/pressure-relief valve, pressure-relief valve and expansion control valve.

- (ii) Stored water temperature in accordance with [Clause 1.11.2](#).
  - (iii) Hot water delivery temperature limitation.
  - (iv) Water level in a gravity-type system.
  - (v) Inlet isolating valve, fully open.
  - (vi) Flow rate at outlet points.
  - (vii) Temperature at outlet points.
  - (viii) Pumps.
  - (ix) Air eliminator valves.
  - (x) Inlet pressures where a reduced pressure valve is installed.
  - (xi) Vibration, noise or water hammer.
  - (xii) Each multiple heater unit shall be checked for operation, individually.
- (e) For a circulating heated water system on completion of Item (d) the following items shall be checked and adjusted for correct operation, as applicable:
- (i) Flow and return temperatures at the water heater or heated water storage vessel.
  - (ii) Temperature, flow rate and velocity at each balancing valve.
  - (iii) Velocity of heated water relating to the return pipework.
  - (iv) Thermal insulation has been installed correctly.
  - (v) Circulating pump(s) operation.
  - (vi) Velocity measurement at the inlet or outlet of the circulating pump(s).
  - (vii) Joints are not leaking when at full operating pressures and temperatures.
  - (viii) Repeat checks 24 h after commissioning to confirm system operation.
- (f) On completion of Item (e) each balancing valve shall be labelled with a water- and fade-resistant label affixed to the valve, with the following information:
- (i) Identification number.
  - (ii) Valve size.
  - (iii) Design flow rate.
  - (iv) Actual flow rate at completion of commissioning.

## 9.5 Heated water circulating system diagram

For Class 2 to Class 9 buildings, where a circulating heated water system is installed, there shall be water-, fade- and weather-resistant diagram(s) that conform to the following:

- (a) A diagram shall be permanently affixed in a prominent location adjacent to the circulation pumps.
- (b) The diagram shall be not less than A3 in size and not more than A1 in size.

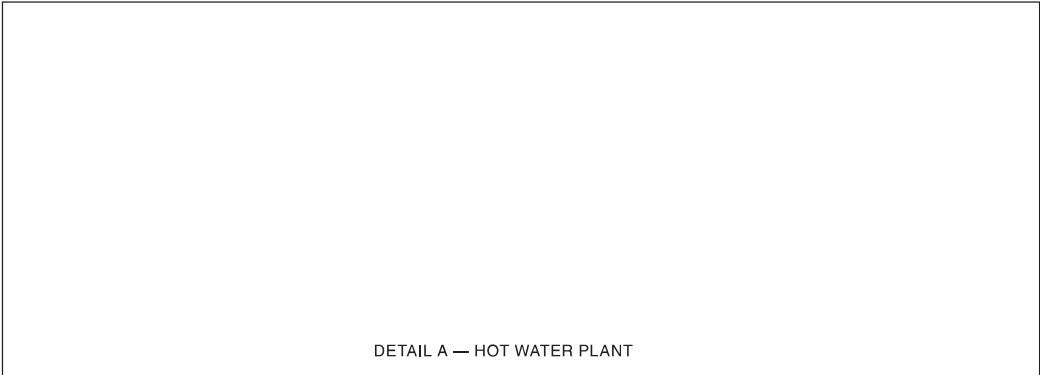
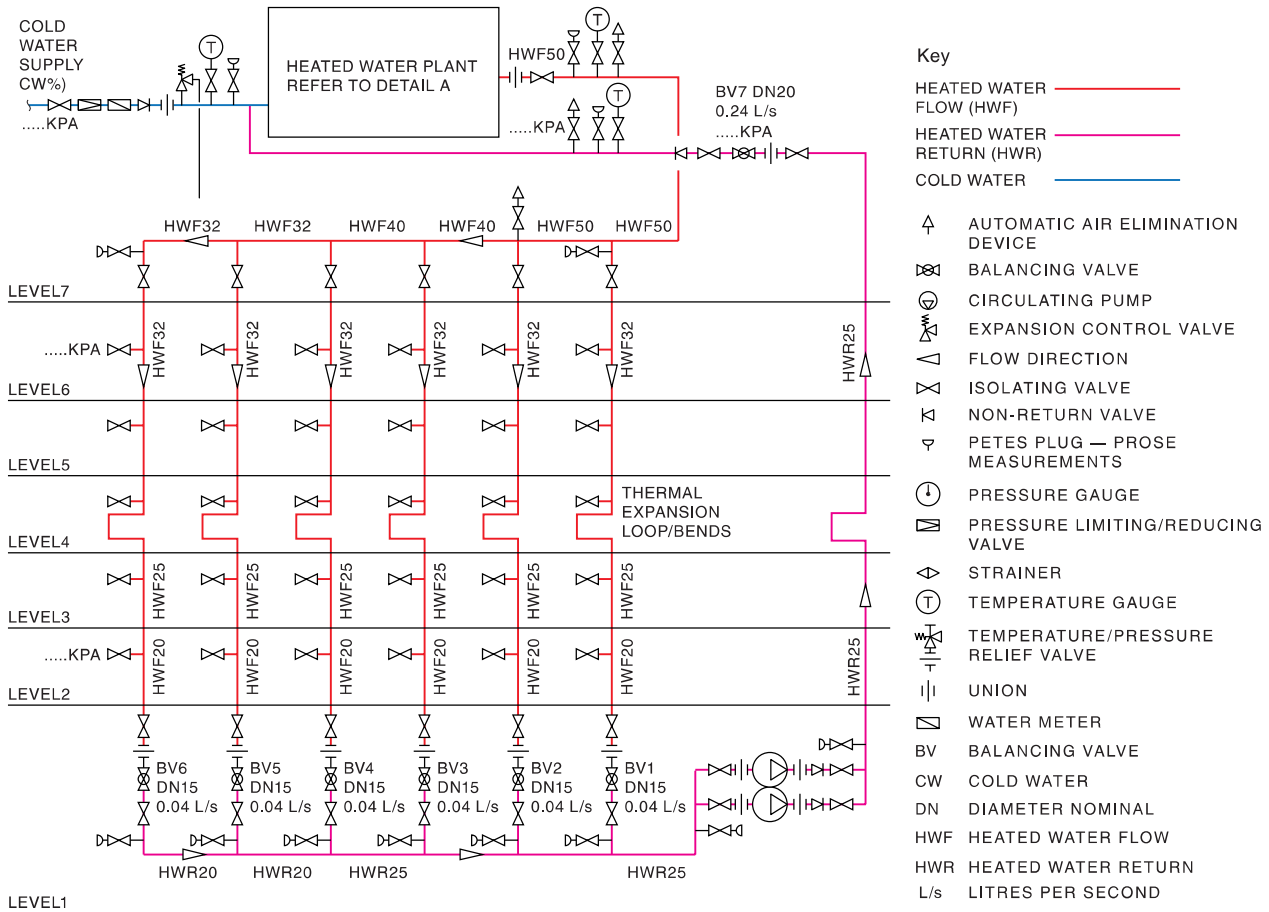
NOTE 1 Where a single diagram cannot appropriately represent the size and or complexity of the building or buildings, consideration should be given to the provision of multiple diagrams.

- (c) The diagram shall display a diagrammatic layout of the circulatory heated water piping and the water heating plant.

NOTE 2 A typical diagram is shown in [Figure 9.5](#).

NOTE 3 A diagram is also recommended for Class 1A buildings.

- (d) The diagram shall include a schematic diagram showing the following:
- (i) The source and size of the cold water supply to the water heating plant.
  - (ii) Water heating plant capacity, recovery rate and fuel source.
  - (iii) The pressure and flow of the cold water supply to the water heating plant.
  - (iv) Expansion valves, expansion vessels and relief valves.
  - (v) Temperature setting for pipe system over temperature alarm.
  - (vi) Circulation pump configuration including valves.
  - (vii) Circulation pump activation.
  - (viii) Pressure and flow duties of circulation pumps.
  - (ix) For circulation pumps with adjustable speed setting the speed setting used for commissioning.
  - (x) The maximum flow and velocity for each section and pipe size as used for commissioning.
  - (xi) Pressure zones, maximum and minimum pressures.
  - (xii) Balancing valves size, type, identification number and location.
  - (xiii) Pipe material.
  - (xiv) Pipe sizes.
  - (xv) Location of isolation valves.
  - (xvi) Location of expansion loops, offsets and fittings.
- (e) The diagram shall include —
- (i) the year of installation of the circulatory piping system;
  - (ii) any alterations or extensions to the system beyond the original installation date;
  - (iii) the name of the contractor who installed or modified the system; and
  - (iv) the name of the commissioning agent who commissioned the system.



SYSTEM INFORMATION	
AUSTRALIAN STANDARD: AS/NZS 3500.4	CIRCULATING PUMPS DUTY 0.24 L/s @ * M/H (Each pump)
YEAR OF INSTALLATION/MODIFICATION:.....	HOT WATER HEATER PLANT CAPACITY/RECOVERY: 2400 LITRES 1ST HOUR & 900 LITRES RECOVERY
DATE OF COMMISSIONING:.....	BALANCING VALVE TYPE:.....
MATERIAL: COPPER TYPE B/PPR/STAINLESS STEEL 316	TOTAL NUMBER OF BALANCING VALVES: 7
CIRCULATING PUMP OPERATION: DUAL-DUTY/STANDBY	HEATING PLANT EBERGY SOURCE; NATURAL GAS
AUTOMATIC CHANGE OVER 24 HR	
CIRCULATING PUMP SPEED SETTING: SPEED 3	
COMMISSIONING AGENT INFORMATION	INSTALLER INFORMATION
INSTALLER NAME:..... PLUMBING PTY LTD	INSTALLER NAME:..... PLUMBING PTY LTD
ADDRESS:.....	ADDRESS:.....
ABN:.....	ABN:.....
CONTRACTORS LICENCE NUMBER:.....	CONTRACTORS LICENCE NUMBER:.....

Figure 9.5 — Typical circulatory heated water diagram

## 9.6 Operating instructions

Operating instructions including an electronic copy of the diagram shall be made available to the owner or occupier of the premises.

## Section 10 Sizing and installation of circulatory heated water reticulation

### 10.1 Scope of section

This section sets out minimum requirements for the sizing and installation of forced circulation heated water reticulation installations limited to 65 °C.

NOTE This section does not apply to forced-circulation warm-water (<55 °C) reticulation installations.

### 10.2 Temperature requirements

The delivery temperature flowing from a water heater, bank of water heaters or a heated water storage vessel shall be not less than 60 °C.

The return water temperature to a water heater, bank of heaters or heated water storage vessel shall be not less than 55 °C.

NOTE 1 See [Clause 2.2](#) for selection of suitable materials.

NOTE 2 Generally, a thermostatic mixing valve and tempering valve require a minimum of 10 °C of temperature differential to operate correctly. For example, to provide 50 °C at the outlet 60 °C temperature is required at the valve, or to provide 45 °C at the outlet 55 °C temperature is required at the valve.

NOTE 3 A water heater delivery temperature set point of 65 °C is sufficiently hot for most applications.

### 10.3 Flow requirements

#### 10.3.1 General

The circulatory heated water reticulation system shall be sized to meet the probable simultaneous demand (PSD) requirements of the fixtures connected to the heated water installation.

NOTE See [Table O.1](#) for a guide to determine the PSD from estimated loading units (LUs) for residential buildings.

#### 10.3.2 Flow rates

The flow rates to fixtures, appliances, taps and valves shall be not less than the flow rates specified in [Table 10.3.2](#).

A heated water outlet from a shower, basin, kitchen sink or laundry trough shall have a maximum flow rate of not more than 9 L/min.

NOTE These requirements do not apply to a shower intended to provide rapid drenching of a person for emergency purposes.

**Table 10.3.2 — Flow rates and loading units for heated water**

Fixture/appliance	Flow rate L/s	Flow rate L/min	Loading units
Bath	0.15	9	4
Basin (standard outlet)	0.10	6	1
Spray tap	0.03	1.8	0.5
Shower (heated water in a mixed flow)	0.10	6	2
Sink (standard tap)	0.12	7	3
Sink (aerated tap)	0.10	6	2
Laundry trough	0.12	7	3

**Table 10.3.2 (continued)**

Fixture/appliance	Flow rate	Flow rate	Loading units
	L/s	L/min	
Washing machine/dishwasher	0.10	6	2
NOTE 1 Flow rates and loading units are applicable to domestic applications. For commercial applications refer to the technical specifications of the fixture outlet.			
NOTE 2 In the case of valves and appliances where test information indicates that they will function satisfactorily with a flow rate less than that shown in this table, the tested flow rate may be substituted and the loading units adjusted accordingly.			
NOTE 3 This table does not make allowance for commercial fixtures.			

### 10.3.3 Loading units

Loading units are factors that take into account the flow rate, length of time in use and frequency of use of the fixture or appliance. Loading units for fixtures/appliances shall be in accordance with [Table 10.3.2](#).

### 10.3.4 Continuous demand outlets

The flow rate from outlets connected to the heated water reticulation system which have a continuous demand shall not be included in the summary of loading units.

The flow rate from continuous demand fixtures shall be added to the estimated flow rate determined from the loading units summary.

NOTE Examples of continuous demand include commercial washing machines and commercial kitchens.

### 10.3.5 Probable simultaneous demand

Probable simultaneous demand (PSD) shall be determined by adding up the total connected loading units in the system and applying a suitable diversity factor to the total connected loading units and then adding the flow rates from any continuous flow fixtures to the flow rates determined from the diversity factor applied to the loading units.

NOTE 1 See [Appendix O](#) for examples of flow rates determined from the total of loading units.

NOTE 2 Diversity factors relate to the intended use of the building and peak demand rate. Sports stadiums for example have different peak demand rates to offices and residential buildings.

### 10.3.6 Probable simultaneous flow rate

Conversion of loading units to probable simultaneous flow rate (PSFR) for branch piping within dwellings shall be as given in [Table 10.3.6](#).

NOTE 1 A method for sizing piping within dwellings is shown in AS/NZS 3500.1:2021 [Appendix D](#).

NOTE 2 Flow rates may be used to estimate the minimum size of piping within dwellings.

**Table 10.3.6 — Probable simultaneous flow rates**

Loading units	PSFR L/s	Loading units	PSFR L/s	Loading units	PSFR L/s
1	0.09	21	0.39	41	0.55
2	0.12	22	0.40	42	0.56
3	0.14	23	0.41	43	0.57
4	0.16	24	0.42	44	0.58

**Table 10.3.6** (continued)

Loading units	PSFR L/s	Loading units	PSFR L/s	Loading units	PSFR L/s
5	0.18	25	0.43	45	0.58
6	0.20	26	0.43	46	0.59
7	0.22	27	0.44	47	0.60
8	0.24	28	0.45	48	0.60
9	0.25	29	0.46	49	0.61
10	0.26	30	0.47	50	0.62
11	0.28	31	0.48	51	0.62
12	0.29	32	0.49	52	0.63
13	0.30	33	0.49	53	0.64
14	0.31	34	0.50	54	0.64
15	0.33	35	0.51	55	0.65
16	0.34	36	0.52	56	0.65
17	0.35	37	0.52	57	0.66
18	0.36	38	0.53	58	0.67
19	0.37	39	0.54	59	0.67
20	0.38	40	0.55	60	0.68

## 10.4 Maximum pressure requirements

### 10.4.1 Maximum pressure within buildings

Provision shall be made to ensure that the maximum working pressure at any heated water outlet within a building does not exceed 500 kPa.

NOTE Pressure above 500 kPa can cause damage from water hammer, reduced life of appliances, taps, pipes and fittings and cause excessive noise in the system.

### 10.4.2 Maximum differential

Where heated water is mixed with cold water at a mixing valve or combined tap, the dynamic pressure differential between the heated and cold water supplies shall not exceed 10 %.

NOTE 1 Where storage tanks or booster pumps may be required to achieve minimum pressure, both the cold water service and the water heater should be supplied from the same source.

NOTE 2 Limiting the pressure differential reduces the likelihood of crossflow across the mixing valve or combined tap.

**C10.4.2** *Crossflow of cold water into a heated water secondary circulating flow at mixing valves or combined taps will reduce heated water delivery temperature at downstream outlets. Transfer of heated water into a cold water service increases the likelihood of legionella bacteria growth and increases heat losses from the system, resulting in increased energy consumption.*

## 10.5 Pressure requirements for circulatory heated water systems

Pressure requirements for circulatory heated water systems shall be in accordance with [Clause 1.9](#).

## 10.6 Velocity requirements

### 10.6.1 Circulating pumps

#### 10.6.1.1 Return pipe

The internal diameter of the return pipe shall be not less than 10 mm.

The maximum velocity in the return pipe shall be 1.0 m/s.

#### 10.6.1.2 Sizing circulating pumps

Friction and head losses shall be calculated along the hydraulically most disadvantaged pipe run, including losses at all check valves, water heaters and other associated equipment. The pump shall be sized to achieve the required flow rate to maintain a circuit temperature drop of not greater than 5 °C.

NOTE The circulating pump is only required to overcome the head losses when all outlets are closed and the system is operating at the flow rate to achieve the temperature drop.

*C10.6.1.2 Increasing thermal insulation and locating circulating heated water pipes into warmer ambient air temperature will reduce heat loss and increase efficiency of the system.*

### 10.6.2 Velocity, pressure and temperature

Velocities, pressures and temperatures associated with water flowing through forced secondary circuits shall not exceed the limits specified for the materials and components in the system.

## 10.7 Expansion of heated water

Any allowance at the water heater for relieving pressure increase caused by the heating of water shall include the capacity of the secondary flow and return piping.

NOTE See [Clause 5.8](#).

## 10.8 Air elimination

### 10.8.1 General

All circulatory heated water piping shall be designed and installed with air elimination valves to eliminate air that can become entrained.

### 10.8.2 Air elimination valves

Automatic air elimination devices shall be installed —

- (a) at the highest point or points of the circulatory piping;
- (b) on the secondary flow adjacent to the water heater or bank of water heaters;
- (c) in an accessible location; and
- (d) with a connected drain delivering over a tundish.

Automatic air elimination devices shall not be installed on the suction side immediately prior to the pump.

**C10.8.2** *Trapped air in circulatory heated water pipe systems can lead to increased corrosion of pipes as well as cause column separation which causes water hammer, pressure surges and cavitation.*

*Water hammer is caused by sudden changes in velocity. Trapped air leading to column separation and fast acting valves or tapware can be causes of water hammer within heated water pipework. Piping should be designed so that entrapped air is automatically removed and pipes are sized to minimize the effect of pressure shock.*

*Cavitation is the formation of vapour bubbles within a liquid, which can occur due to rapid drop in pressure. When a vapour bubble collapses it generates an immediate pressure shock wave of several thousand kilopascals and extreme temperatures. Vapour bubbles that collapse near a pipe wall or surface will over time cause significant damage to the piping material. Cavitation damage is more likely to occur in heated water piping systems at higher water temperatures due to a reduced vapour pressure of the liquid. As the temperature of water increases and the pressure decreases the ability of a liquid to contain dissolved gases reduces and vapour bubbles form. The damage to pipes typically occur when vapour bubbles are present and the pressure of the system increases, forcing the vapour bubbles to implode. Heated water plant located on the roof tops of high-rise buildings with the piping system circulating down throughout the building are particularly susceptible to these actions. Where the heated water plant is located within the basement of high-rise buildings it is the return pipe that becomes susceptible to damage. Central heated water systems should be designed and installed to eliminate the damaging effects of cavitation.*

## 10.9 Location of circulatory piping

### 10.9.1 General

Flow and return heated water piping that services more than one apartment, dwelling or secure area shall be located in the common property, subject to the limitations of [Clause 4.6](#).

NOTE Common property in this instance is an area that can be accessed without having to enter into an individual apartment or dwelling.

### 10.9.2 Branch off-takes

Circulatory piping shall be located so that dead leg branch off-takes are as close as practicable to the most frequently used outlet point or points serviced by a branch.

NOTE See also [Clause 4.13.1](#).

### 10.9.3 Branch off-take with meter

#### 10.9.3.1 General

A heated water meter on a dead leg branch serving a single apartment, dwelling or secure area shall be located in common property and be accessible by the individual apartment, dwelling or secure area occupier.

NOTE A secure area comprises buildings or rooms, other than apartments or dwellings, that are used by and under the control of an individual or organization. Such areas include shops or commercial offices.

#### 10.9.3.2 Length and capacity of dead leg with meter

The circulatory flow, the branch offtake and the heated water meter located in the common property shall be installed as close as practicable to the apartment, dwelling or secure area they serve.

NOTE 1 Volumetric capacity of pipes are given in [Table Q.2](#).

NOTE 2 See [Appendix Q](#) for a guide to determine capacity of dead legs and estimating wait times.

NOTE 3 Dead legs with volumetric capacity exceeding 2 L may require additional water heaters or trace heating.

NOTE 4 See [Table 8.2.2](#) for pipe insulation requirements.

NOTE 5 See [Figure Q.3](#) for the volumetric capacity of any dead leg, measured from the branch offtake at the circulatory flow to its outlet, should not exceed 2 L.

#### 10.9.4 Proximity to cold water piping

Flow and return heated water pipe systems shall be designed so as to prevent unintentional transfer of heat to any cold water service.

NOTE This may be achieved through one or more of —

- (a) installing circulating heated water pipes in separate duct to cold water services;
- (b) additional thermal insulation to the heated water pipes;
- (c) applying thermal insulation to the cold water pipes; or
- (d) ventilating the duct to expel warmed air.

### 10.10 Isolating valves

#### 10.10.1 General

The flow within circulating piping including branches shall be controlled by means of isolating valves.

#### 10.10.2 Location

Isolating valves shall be installed at the following locations:

- (a) The outlet and return connections to a water heater or heated water storage vessel subject to the limitations of [Clause 5.10](#).
- (b) Branch off-takes.
- (c) Branch off-takes and returns from and to the main flow and return piping for both vertical and horizontal sub flow and return circuits.
- (d) Branch off-takes serving any individual apartment, dwelling or secure area and be accessible by the individual apartment, dwelling or secure area occupier.
- (e) The inlet to any heated water meter.
- (f) The inlet to each air elimination valve.
- (g) Each testable backflow prevention device.
- (h) Each pressure-limiting or pressure reduction valve.
- (i) The delivery side and suction side to each pumping apparatus.

#### 10.10.3 Multiple apartments, dwellings and secure areas

An isolation valve installed on a branch serving an individual apartment, dwelling or secure area shall be accessible by the individual occupier from common property.

The isolation of flow and return piping to any individual apartment, dwelling or secure area shall not limit the supply to any other area.

## 10.11 Balancing valves

### 10.11.1 General

Balancing valves shall be installed to control the temperature within a circulating heated water system by dynamically adjusting the flow rate in a branch or circuit.

### 10.11.2 Commissioning

Balancing valves shall be commissioned in accordance with [Clause 9.4](#).

## Appendix A (informative)

### Water analysis

#### A.1 Water analysis

Water analysis should be performed by an accredited analytical laboratory.

NOTE When heated, some waters may produce excessive scaling due to the deposition of calcium carbonate. This type of scaling can eventually lead to the blockage of valves, pipes and specially tubes in solar collectors.

#### A.2 Conductivity and total dissolved solids

The selection of anode should be made, based on the conductivity of the water.

NOTE 1 The concentration of the total dissolved solids (TDS) affects the conductivity.

NOTE 2 Anode selection should be made in accordance with the manufacturer's recommendation or, in the absence of such a recommendation, see [Table A.2](#).

**Table A.2 — Anode selection**

Anode material <sup>a</sup>		
TDS mg/L		
0-50	50-400	> 400
M1	M2	A5
<sup>a</sup> Refer to AS 2239.		

## Appendix B (informative)

### Demonstrating products and materials are fit for purpose

#### B.1 General

The products and materials used should be selected to ensure that they are fit for their intended purpose (see [Clause 2.2](#)) taking into account the following factors—

- (a) the type of usage likely to occur;
- (b) the nature and temperature of the water to be conveyed and the risk of corrosion, degradation and leaching;
- (c) the nature of the environment, the ground and the possibility of chemical attack therefrom;
- (d) the physical and chemical characteristics of the materials and products;
- (e) compatibility of materials and products;
- (f) the pressure rating of pipes and fittings; and
- (g) accessibility for inspection and maintenance.

Information on some of the items listed above may be obtainable from the manufacturer or supplier of the product or material.

#### B.2 Australia

The WaterMark Certification Scheme is a mandatory certification scheme for plumbing and drainage products to ensure they are fit for purpose and appropriately authorized for use in plumbing and drainage installations.

Volume Three of the National Construction Code, the Plumbing Code of Australia (PCA), requires that any product intended for use in contact with drinking water must conform to the relevant requirements of AS/NZS 4020. The PCA also requires certain plumbing and drainage products to be certified and authorized for use in a plumbing or drainage system. These products are certified through the WaterMark Certification Scheme and listed on the WaterMark Product Database.

A comprehensive list of products requiring WaterMark is contained in the WaterMark Schedule of Products which mandates the specification to which the products must be certified. Products listed on the WaterMark Schedule of Products are deemed by the PCA to be fit for their intended purpose if they have a WaterMark licence number.

The WaterMark Schedule of Excluded Products details products that have been predetermined as not requiring WaterMark certification; however, the PCA requires evidence of suitability.

The Australian Building Codes Board update these documents on an irregular basis. The updates generally include the addition of new products that have undergone a risk assessment and that are determined to require WaterMark certification, as well as updates to specifications that are approved for use, revised or suspended.

Products not included on the WaterMark Schedule of Products or the WaterMark Schedule of Excluded Products, which are proposed to be used in a plumbing or drainage system, require an assessment to

be undertaken by a WaterMark Conformity Assessment Body to determine if WaterMark certification is necessary.

The WaterMark Product Database lists products that have been certified and marked in accordance with the requirements of the WaterMark Certification Scheme. These products are recognized by authorities as being authorized for use in a plumbing or drainage system.

NOTE The Plumbing Code of Australia, WaterMark Schedule of Products, Schedule of Excluded Products, and Database can be accessed at <https://www.ABCB.gov.au>

### B.3 New Zealand

Plumbing and drainage systems must be constructed using materials and products fit for their intended purpose to achieve the relevant requirements of the New Zealand Building Code.

For the purposes of conformance to this document, a material or product for plumbing or drainage systems may be deemed fit for purpose if it —

- (a) has been manufactured in accordance with a Standard cited within a current NZBC Acceptable Solution or Verification Method;
- (b) has current certification in accordance with the New Zealand CodeMark Certification Scheme;
- (c) has been certified and marked in accordance with the requirements of the Australian WaterMark Certification Scheme and is listed on the [WaterMark Product Database](#); or
- (d) has been accepted by the approving authority as meeting the performance criteria of the NZBC.

Any product that is intended for use in contact with drinking water must conform to the relevant requirements of AS/NZS 4020. A test report provided by a certification body or an accredited testing laboratory must be provided to demonstrate compliance.

All products must be suitable for use in the location they are used.

An approving authority may prohibit the use of particular materials where local conditions are likely to cause the materials to corrode or otherwise deteriorate.

## Appendix C (normative)

### Internal pipe diameters

This appendix sets out the internal diameter for different nominal diameters (DN), pipe materials and types, standard dimension ratios (SDRs) or pressure classes, as marked on the pipe.

Internal diameters for copper pipes and tubes, stainless steel pipes and tubes, and PE-X, PP-R, PB (metric) polyolefin pipes shall be in accordance with [Tables C.1](#) to [C.3](#). For multilayer pipes, the internal diameters shall be as specified by the pipe supplier.

NOTE 1 Standard dimension ratio (SDR) — Plastics pipes may be categorized by their SDR value. It is the ratio of the nominal outside diameter of the pipe to its nominal wall thickness,  $SDR = DN/T$ . SDR values are printed onto pipes and can be obtained from the pipe manufacturer.

NOTE 2 Values in [Tables C.1](#) to [C.3](#) were calculated from the values for maximum outside diameter and minimum wall thickness as specified in the respective pipe product documents as follows:

- (a) AS 1432 — Copper (Australia).
- (b) NZS 3501 — Copper (New Zealand).
- (c) AS/NZS 2492 — PE-X.
- (d) AS 5082.1 — PB (metric series).
- (e) AS/NZS 2642.2 — PB (imperial series).
- (f) ISO 15874-2 — PP-R.
- (g) AS 5200.053 — Stainless Steel

**Table C.1 — Internal diameters for copper pipes and tubes**

DN	Copper pipes and tubes in accordance with AS 1432 (Australia)			Copper pipes and tubes in accordance with NZS 3501 (New Zealand) mm
	Type A mm	Type B mm	Type C mm	
10	7.5	7.7	8.1	9.5
15	10.7	10.9	11.3	12.7
18	13.4	13.8	14.1	—
20	16.2	17	17.2	19
25	22.1	23	23.6	25.4
32	28.5	29.3	—	31.8
40	34.8	35.7	—	38.1
50	47.5	48.4	—	50.8
65	60.2	61.1	—	63.5
80	72.1	72.9	—	76.2
90	85.8	85.6	—	88.9
100	97.5	98.3	—	101.6
125	122.9	123.7	—	127
150	147.1	148.3	—	152.4

**Table C.1** (continued)

DN	Copper pipes and tubes in accordance with AS 1432 (Australia)			Copper pipes and tubes in accordance with NZS 3501 (New Zealand)
	Type A mm	Type B mm	Type C mm	
200	197.9	199.1	—	188.5

**Table C.2 — Internal diameters for stainless steel pipes and tubes**

DN	Stainless steel pipes in accordance with ASME B36.19M		Stainless steel tubes in accordance with EN 10312
	Schedule 5S mm	Schedule 10S mm	Series 2 mm
15	18	17.1	13
18	—	—	16
20	23.4	22.5	19.6
25	30.1	27.9	25.6
32	38.9	36.6	32
40	45	42.7	39
50	57	54.8	51
65	68.8	66.9	72.1
80	84.7	82.8	84.9
100	110.1	108.2	104
125	135.8	134.5	—
150	162.8	161.5	—
200	213.6	211.6	—

**Table C.3 — Internal diameters for polyolefin pipes**

PE-X, PP-R, PB (metric)			
DN/OD	SDR 11 mm	SDR 9 mm	SDR 7.4 mm
16	13.1	12.3	11.9
20	16.5	15.7	14.7
25	20.7	19.7	18.3
32	26.5	25.1	23.5
40	33	31.4	29.4
50	41.2	39.3	36.7
63	52	49.4	46.4
75	62.1	58.9	55.1
90	74.5	70.7	66.3
110	91	86.4	80.8
125	103.4	98.2	92
140	115.9	109.9	102.9
160	132.3	125.7	117.7
180	148.9	141.5	132.5
200	165.4	157	147.2

**Table C.3** (continued)

<b>PE-X, PP-R, PB (metric)</b>			
<b>DN/OD</b>	<b>SDR 11 mm</b>	<b>SDR 9 mm</b>	<b>SDR 7.4 mm</b>
NOTE To conform to <a href="#">Clause 2.3(a)(i)</a> : (a) PE-X pipes shall have an SDR $\leq 9$ ; (b) PB pipes shall have an SDR $\leq 11$ ; and (c) PP-R pipes shall have an SDR $\leq 7.4$ .			

## Appendix D (informative)

### Preferred sizes of pipe for non-circulatory typical single-storey household installations

**Table D.1 — Preferred sizes of pipe for non-circulatory typical single-storey household installations**

Feed	Minimum internal diameters of pipe, mm			
	Water heater operating pressure, kPa			
	< 85	85 – 170	> 170	
			Storage	Instantaneous
From heater to first branch	15.0	12.5	12.5	15.0
A branch to kitchen sink or washbasin	10.0	10.0	10.0	10.0
A branch to kitchen sink and laundry	10.0	10.0	10.0	10.0
A branch to bathroom and one other room	15.0	12.5	10.0	10.0
A branch to bathroom only, all pipe in bathroom	12.5	10.0	10.0	10.0

NOTE The above are recommended sizes only. Individual installations may require larger piping to give the flow rates detailed in [Table 10.3.2](#).

## Appendix E (informative)

### Recommendations for the installation of unrated solar heated water supply systems

#### E.1 General

A custom-built system, which may comprise components that are manufactured by different manufacturers and are not specifically designed for use with each other, may not perform in a predictable manner nor be rated. Such systems commonly result from the addition of a new component to an existing component, e.g. solar collectors added to an existing hot water system. However, it is possible to avoid fundamental design mistakes in such systems, and the recommendations provided in this appendix embody what is considered good practice in order to obtain a reasonable solar contribution.

#### E.2 Volumetric storage capacity

The volumetric storage capacity of the container should be not less than the anticipated average daily consumption of the household.

For increased solar performance, a volumetric storage capacity of 1.5 to 2.0 times the anticipated average daily consumption of the household is recommended, see also [Appendix G](#).

For systems using off-peak supplementary electric heating, the volumetric storage capacity of the container should be not less than 1.5 times the anticipated average daily consumption of the household.

#### E.3 Recommended operating temperature

The solar hot water system should incorporate supplementary heating. For the purpose of obtaining an acceptable solar contribution, such supplementary heating (whether integral or remote) should be suitable for operation at 60 °C nominal temperature.

#### E.4 Temperature/pressure-relief valve

The temperature/pressure-relief-valve should be sized to allow for the energy input of the collectors at 99 °C.

#### E.5 Collector/container size ratio

##### E.5.1 Normal conditions

The collector aperture should be related to the volume of the container and to the location of the installation as indicated in [Table G.1](#).

NOTE Slightly less collector aperture will be required for collectors with selective surfaces. Care should be taken to prevent excessive hot water temperatures with selective surface collectors.

Reference should also be made to [Clauses 6.5.2.2](#) and [6.5.2.3](#).

### **E.5.2 Non-optimum conditions**

Where the operation of the collector is adversely affected by shade, inclination, orientation, excessive dust, smog, cloud, or the like, the size of the collector should be increased to compensate.

### **E.6 Components**

Where a system is made up of components that have not been tested as a packaged system in accordance with AS/NZS 2712, the individual components should conform to AS/NZS 2712.

### **E.7 Claimed performance**

Claimed performance of a custom-built system may be related to a tested packaged system where the components have been individually tested and the ratio of collector aperture area to volume of the container are similar for the custom-built system and tested packaged system.

## Appendix F (informative)

### Recommendations for the installation of close-coupled and integral solar heated water supply systems on roofs

#### F.1 General

The installation of a close-coupled or integral solar heated water supply system, which includes a container as well as collectors, on the roof of a building will impose additional loading on the roof structure. Care should be taken to ensure that the roof and building structure are capable of accepting this additional load. The recommendations provided in this appendix are intended as a basic guide to a practice that has been found satisfactory in non-cyclonic areas.

#### F.2 Support

##### F.2.1 “With pitch” installations

Solar heated water supply systems mounted directly onto a roof structure, i.e. “with pitch” installations (see [Figure F.2.1](#)), should be arranged so that their weight is distributed evenly over as many roof rafters as possible. Roof struts supporting underpurlins that are affected by the additional load should be directly supported from loadbearing walls or appropriately designed strutting beams.

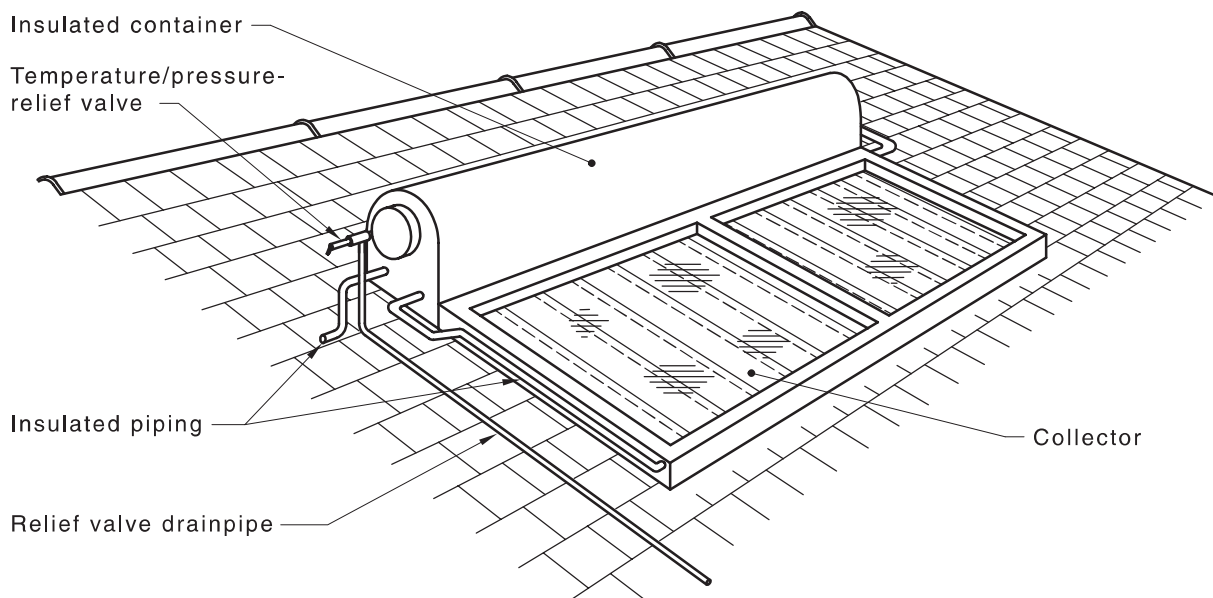


Figure F.2.1 — “With pitch” installation

##### F.2.2 “Against pitch” installations

Solar heated water supply systems mounted on frames above roof structures at angles opposed to the roof pitch, i.e. “against pitch” installations (see [Figure F.2.2](#)), and which cause point loads, should have the container point loads taken through the roof membrane and be directly supported from loadbearing walls or appropriately designed strutting beams.

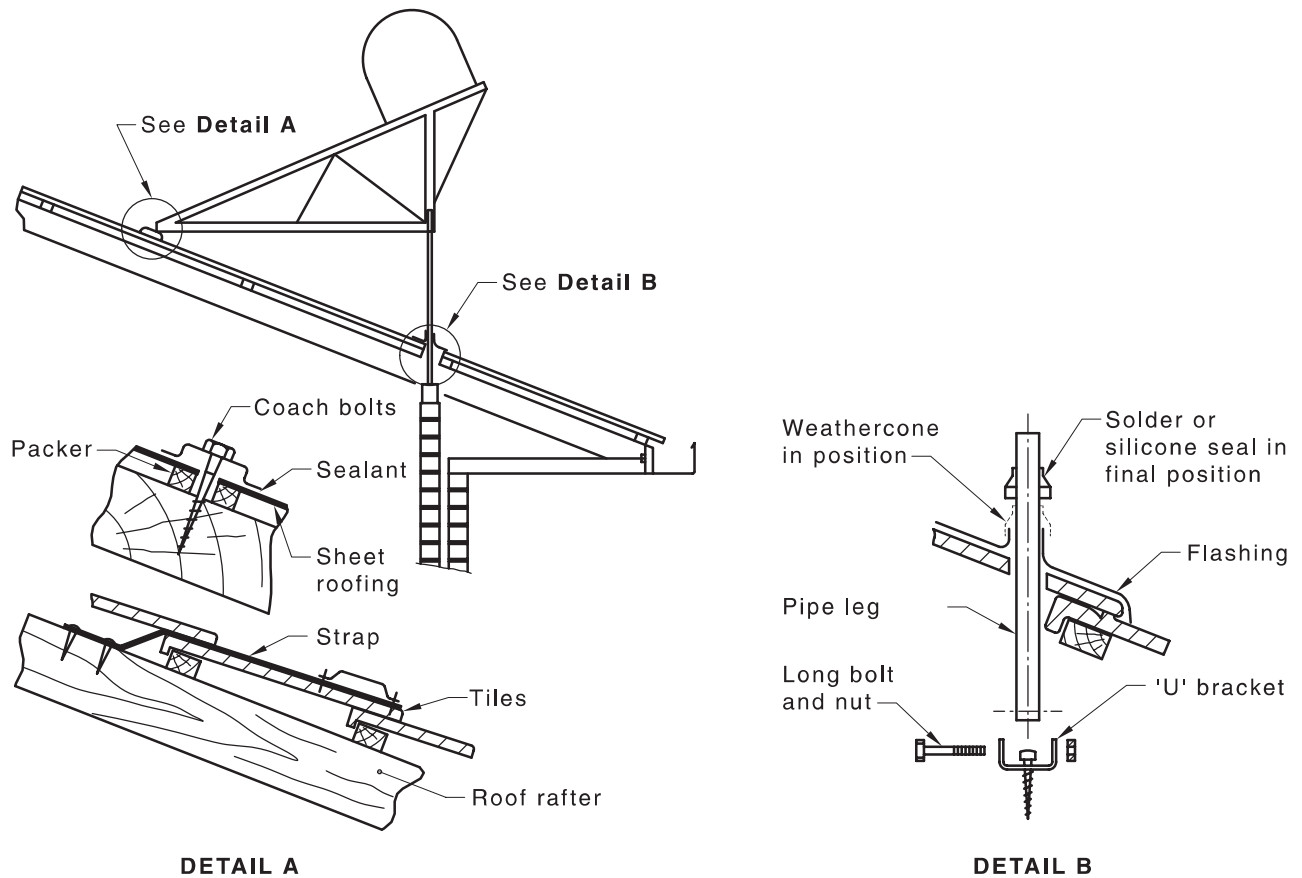
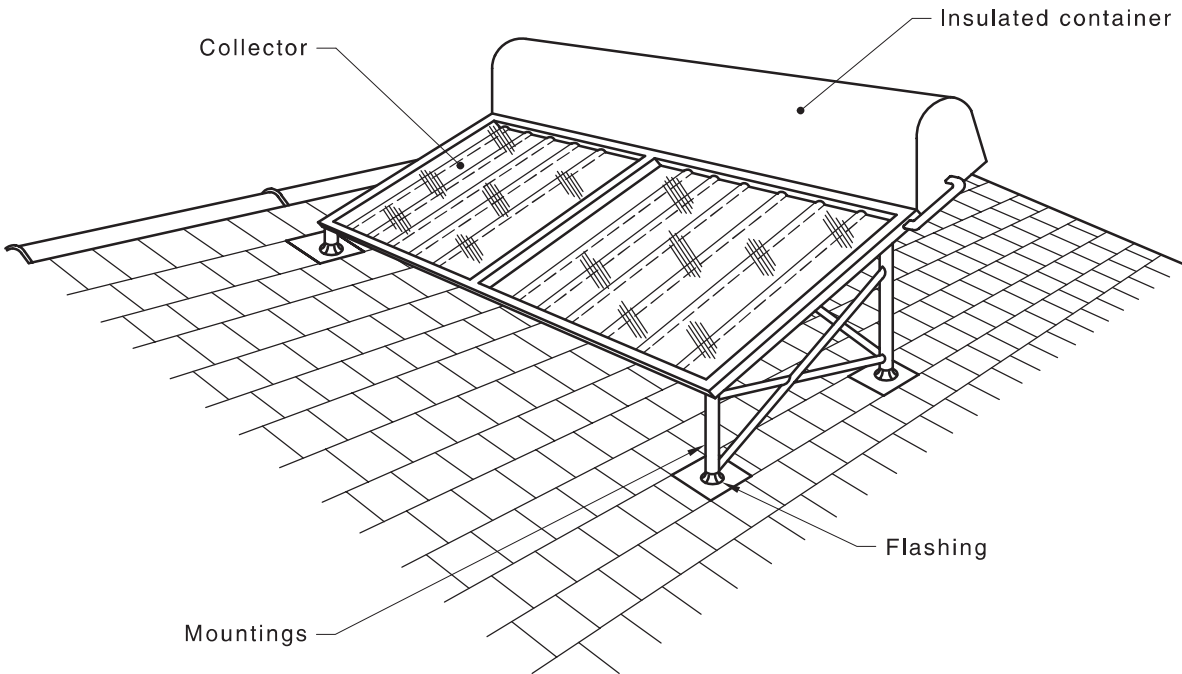


Figure F.2.2 — "Against pitch" installation

### F.2.3 "Cross-pitch" installations

Solar heated water supply systems mounted on frames above roofs across the pitch of the roof, i.e. "cross-pitch" installations (see [Figure F.2.3](#)), and which cause point loads, should be arranged so that one side of the system is directly supported from a loadbearing wall; the other side of the system should be directly supported from a strutting beam taking the load to not less than two timber studs at each end of the beam.



**Figure F.2.3 — “Cross-pitch” installation**

### F.3 Points to note

When installing close-coupled and integral solar water heaters, the following precautions should be observed:

- (a) The internal structure of the existing roof and the soundness of the roof timbers should be checked. Based on these observations or the recommendations of an engineer's report, additional strengthening may be required.
- (b) Containers should not be placed in the middle of the roof over a large room.
- (c) Where possible, the container should be located towards the apex of the roof and over bathroom or laundry areas, where the internal roof structures are usually supported from internal walls.
- (d) Particular attention should be paid to installations on sheet-clad roofs. The generally wider timber spacings may require each rafter affected by the additional load to be strengthened or provided with additional support.
- (e) On roofs where it is not possible to make an internal inspection, or where inspection reveals marginal agreement with the recommendations of this document, a further check should be made with the building authority prior to proceeding with the installation.
- (f) Where a secondary metallic tile roofing has been installed over the initial roof cladding, any fixings that can be made to the roof members, should be made to the original roof structure and not to any secondary roofing members.

## Appendix G (informative)

### Solar heated water supply systems — Suggested component sizes (custom-built systems)

#### G.1 Anticipated solar fraction

The anticipated solar fraction ( $f$ ) listed in [Table G.1](#) is for typical solar heated water supply systems installed in houses and incorporating a well-designed flat plate collector with a well-insulated container having a draw-off capacity not less than 80 % container storage volume. However, the values for storage container capacity and collector area do not necessarily relate to any particular commercially available close-coupled systems. All data presented in this appendix correspond to the average requirements of a four-person household.

**Table G.1 — Suggested component sizes (custom-built systems)**

1	2	3	4	5
Location	Collector		Container storage L	Anticipated solar fraction ( $f$ ) %
	Angle of inclination degrees	Area m <sup>2</sup>		
Adelaide	35 (35)	4	315	74
Alice Springs	32 (24)	4	315	94
Auckland	35 (37)	4	360	65
Brisbane	29 (27)	4	315	81
Christchurch	35 (43.5)	4	360	60
Canberra	33 (35)	4	315	67
Darwin	15 (12)	3	270	97
Hobart	42 (43)	5	360	65
Invercargill	20 (40)	4	360	56
Melbourne	38 (38)	5	360	67
Perth	33 (32)	4	315	77
Sydney	34 (34)	4	315	76
Wellington	35 (41)	4	360	60

NOTE 1 Column 2 — Nominal angle of inclination of flat plate collector to horizontal (see [Clause 6.5.1.4](#)). Latitude angle is shown in parentheses.

NOTE 2 Column 3 — Collector aperture area, expressed in square metres. This area is for optimum conditions of collector inclination and orientation. For non-optimum conditions, the solar fraction will be reduced (see [Appendix J](#)) and a greater area may be required.

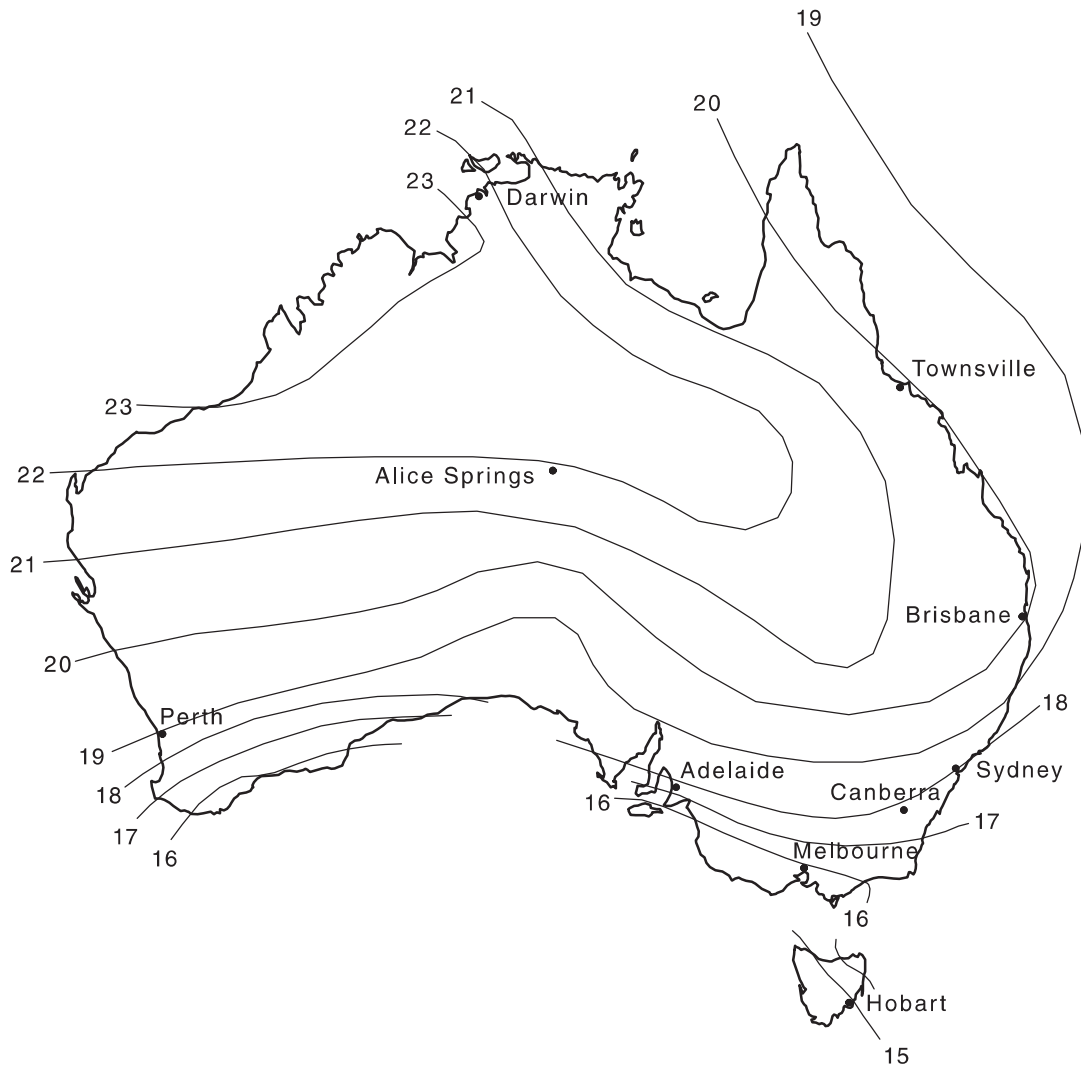
**Table G.1 (continued)**

1	2	3	4	5
Location	Collector		Container storage  L	Anticipated solar fraction ( <i>f</i> )  %
	Angle of inclination degrees	Area m <sup>2</sup>		
<p>NOTE 3 Column 5 — Anticipated average annual solar energy fraction (<i>f</i>) expressed as a percentage of total hot water energy delivered, i.e. —</p> $f = \frac{E_{wh} - E_p}{E_{wh}} \times 100$ <p>where</p> <p><math>E_{wh}</math> = hot water energy delivered at water heater outlet (mass × specific heat capacity × temperature differential)</p> <p><math>E_p</math> = total supplementary energy purchased for water heating</p> <p>NOTE 4 The actual solar fraction will vary with household hot water use patterns and with weather variations from year to year. The figures given should be accurate to within 5 % for normal situations.</p>				

## G.2 Solar radiation data

Basic solar radiation data are given in [Figures G.3\(A\)](#) and [G.3\(B\)](#) for Australia and [Figure G.3\(C\)](#) for New Zealand.

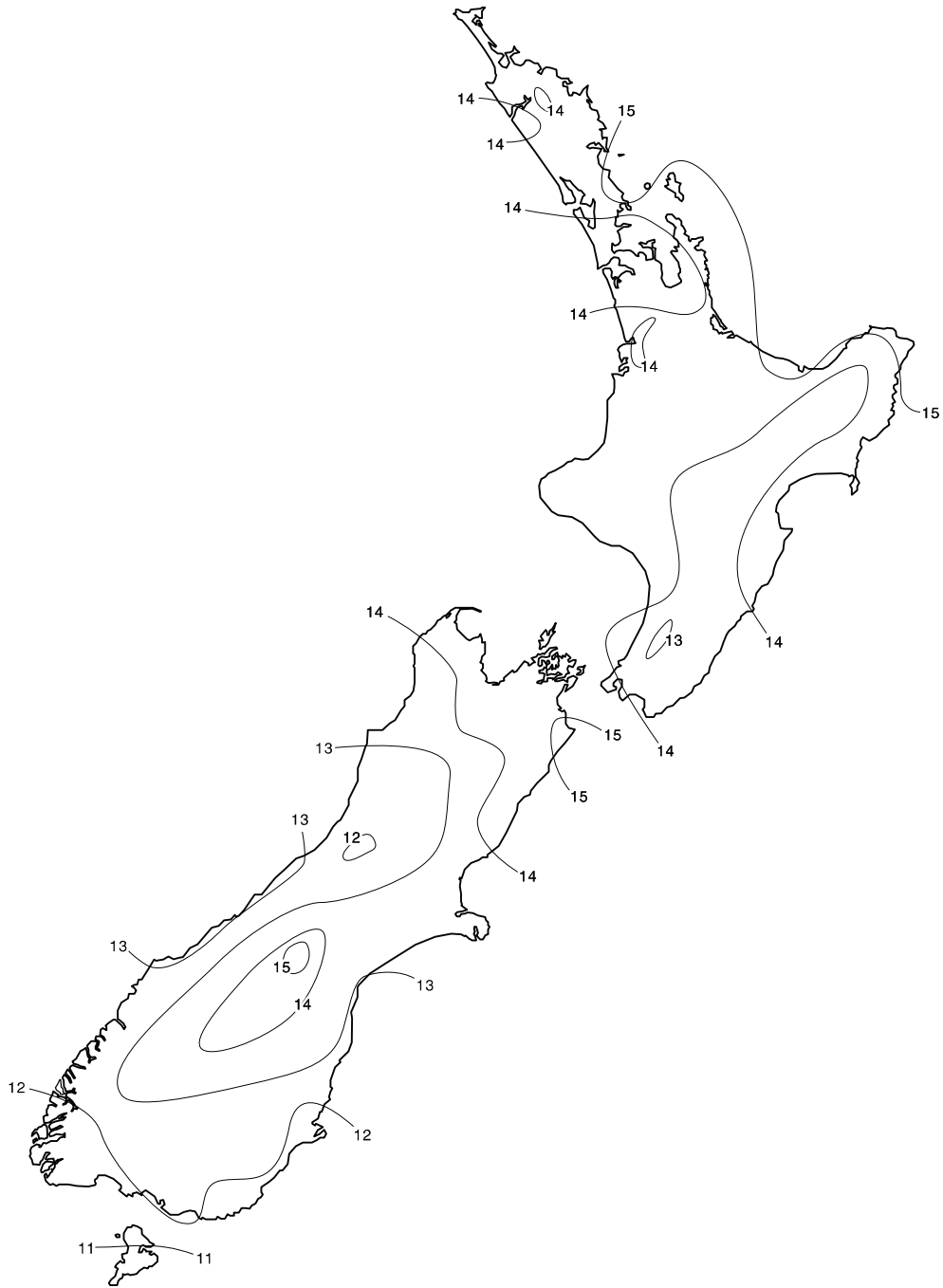
NOTE For more comprehensive information on solar radiation in Australia, refer to the *Australian Solar Radiation Data Handbook* and in New Zealand, refer to the National Institute of Water and Atmospheric Research.



**Figure G.3(A) — Contours of annual mean daily solar radiation on a horizontal surface (MJ/m<sup>2</sup>.d)**

Copyrighted material licensed to TASTAFE by Techstreet LLC. Subscriptions: techstreet.com, downloaded on 2023-10-05 22:36:19 +0000 by TASTAFE User. No further reproduction or distribution is permitted.





**Figure G.3(C) — Contours of annual mean daily solar radiation on a horizontal surface (MJ/m<sup>2</sup>.d)**

## Appendix H (informative)

### Estimation of shading of collectors

#### H.1 General

In order to be able to assess whether or not collectors will be subject to shading during the year, it is necessary to know the solar altitude for the installation location when the sun is at its lowest, i.e. in mid-winter. As most of the useful solar radiation is received within 3 h either side of solar noon for any system installed at or near the recommended orientation and inclination, any significant shading of collectors in these hours, i.e. 9 am to 3 pm standard time, will affect the performance of such a system, and should be avoided in locating the unit. [Table H.1](#) lists the solar altitude at mid-winter for various locations in Australia and New Zealand. By checking the solar altitude, as observed at the lower edge of the collectors, the installer can determine whether or not nearby buildings, trees or other obstructions will cast a shadow on the collector. For example, if a building, observed from the base of the collectors, is above the mid-winter solar altitude, then that building will cast a shadow on the collectors.

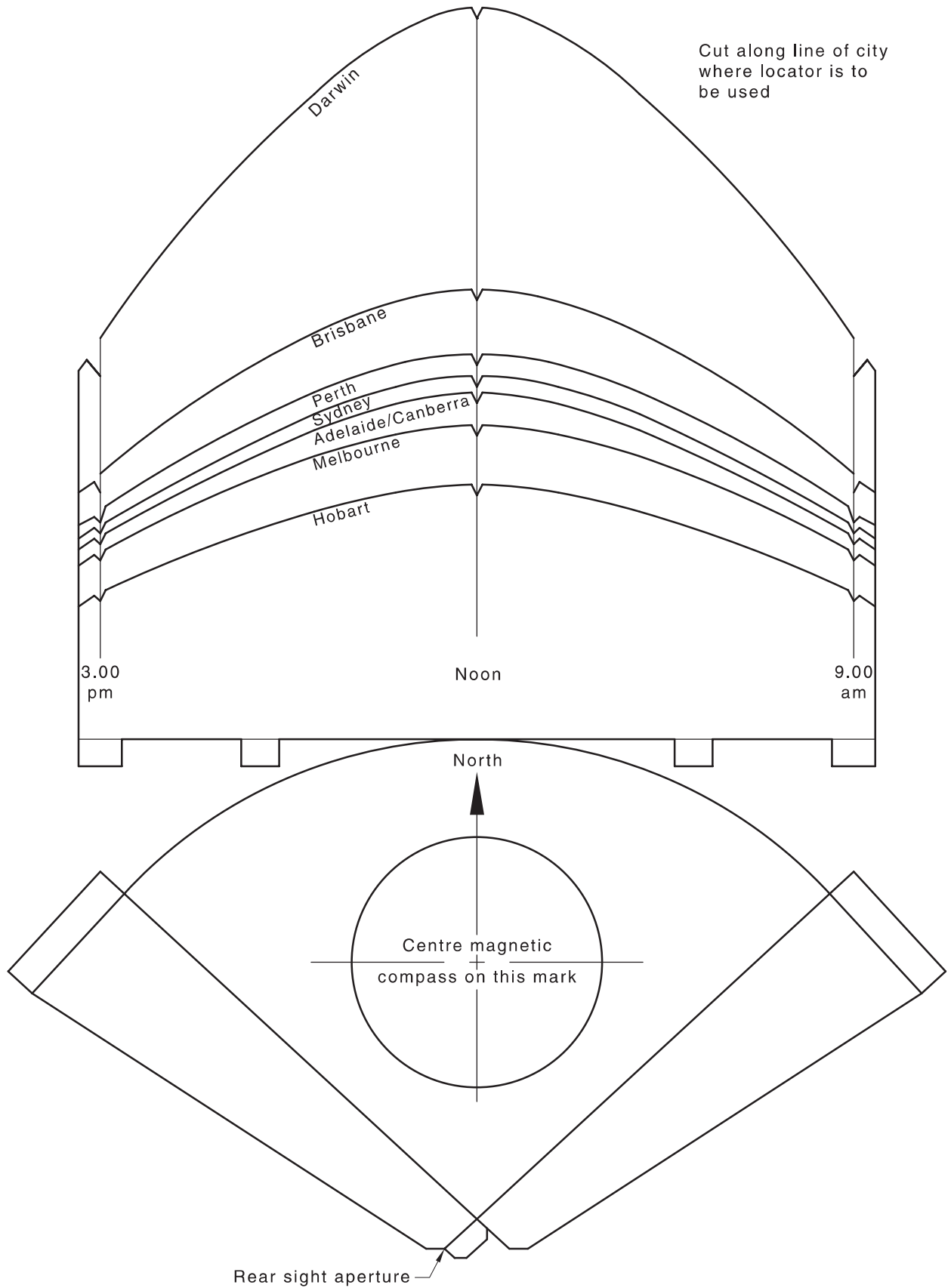
**Table H.1 — Solar altitude at mid-winter**

City	Latitude	Solar altitude		
	degrees	9 am	Noon	3 pm
Darwin	12	33.5	54.5	33.5
Brisbane	27	23.4	39.5	23.4
Perth	32	19.8	34.5	19.8
Sydney	34	18.3	32.5	18.3
Adelaide	35	17.6	31.5	17.6
Canberra	35	17.6	31.5	17.6
Auckland	37	16.1	29.5	16.1
Melbourne	38	15.4	28.5	15.4
Devonport	41	13.2	25.6	13.7
Wellington	41	13.2	25.5	13.2
Hobart	43	11.7	23.6	11.7
Christchurch	43.5	11.2	23	11.2
Invercargill	46	9	20	9

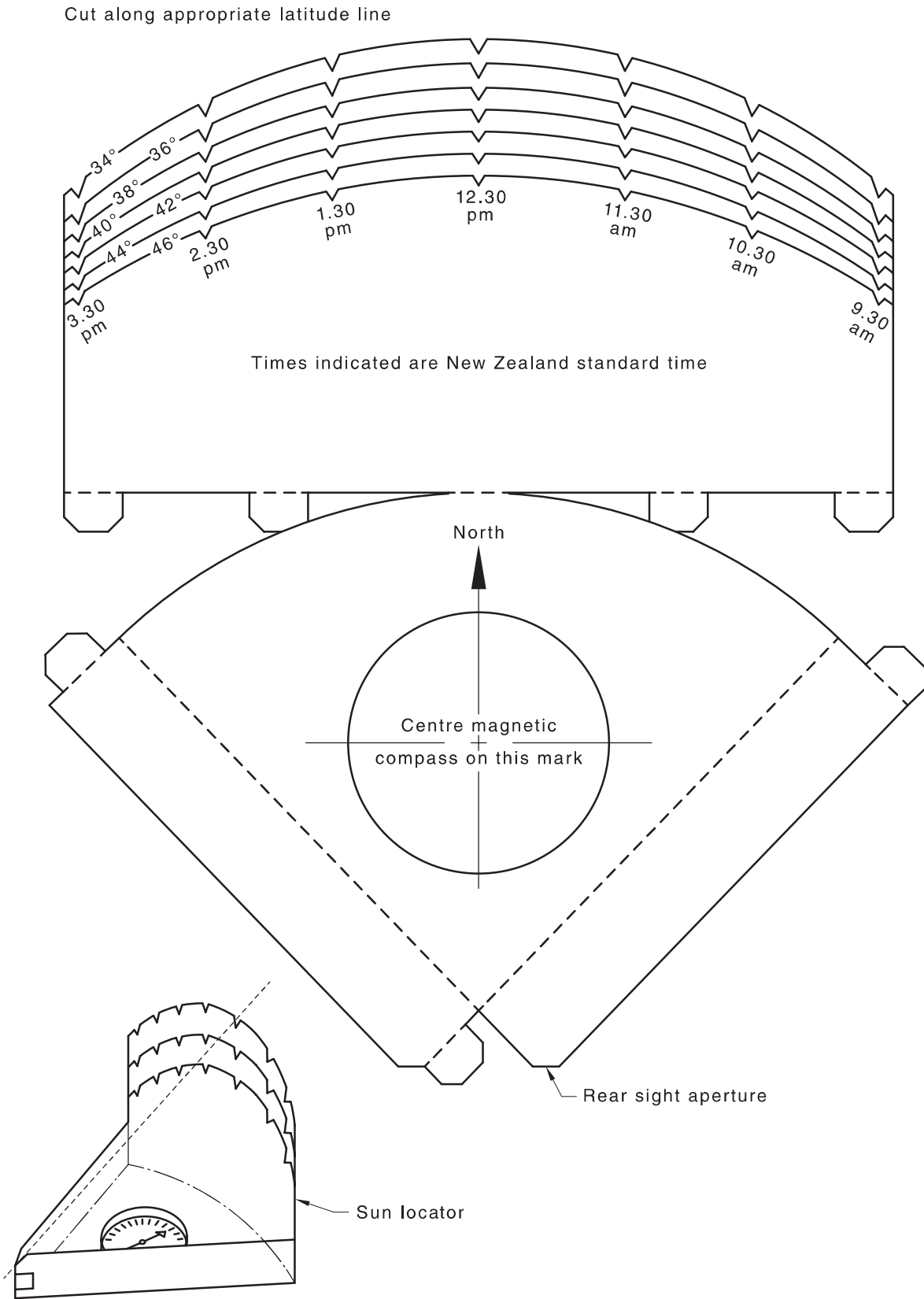
#### H.2 Sun locator

The mid-winter solar altitude may be checked using a commercial “sun locator”; however, a simple solar altitude sight may be constructed from the diagram in [Figure H.2\(A\)](#) for Australia and [Figure H.2\(B\)](#) for New Zealand. The diagram may be glued to cardboard, or preferably reproduced to a larger scale on cardboard, and then cut out and assembled. An assembled sight is shown in [Figure H.2\(C\)](#).

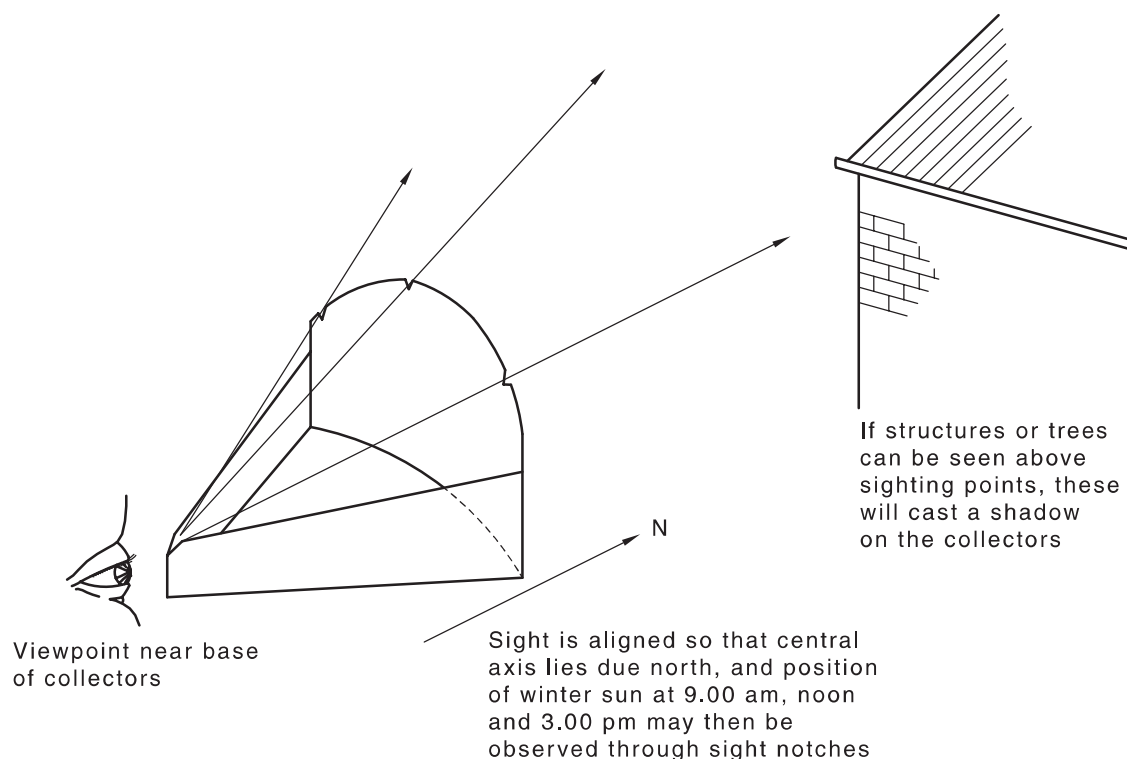
The solar altitude sight is used by aligning the arrow due north, using a compass or map, and with the base of the sight horizontal, sighting the 9 am, noon and 3 pm positions of the winter sun, from a viewpoint near the base of the solar collectors. Any objects that can be seen above the sight will cast a shadow on the collector in winter. The use of the solar altitude sight is shown in [Figure H.2\(C\)](#).



**Figure H.2(A) — Mid-winter solar altitude sight (Australia)**



**Figure H.2(B) — Mid-winter solar altitude sight (New Zealand)**

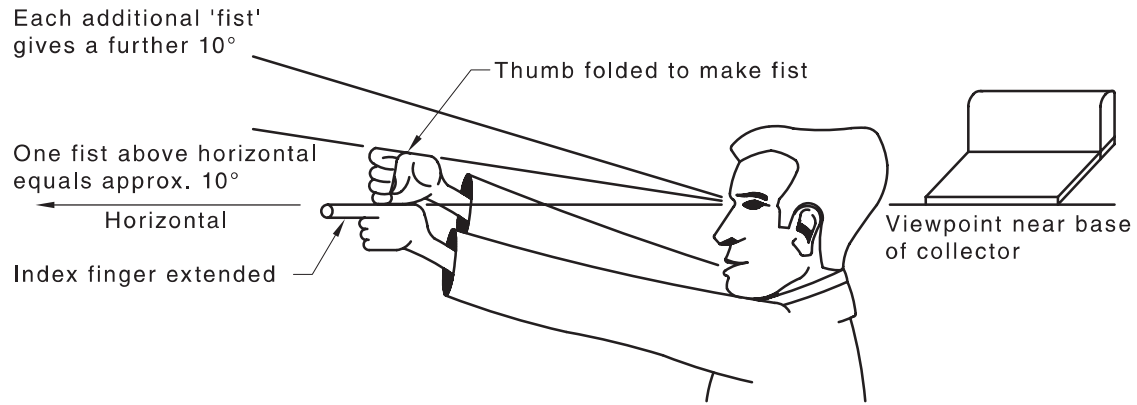


**Figure H.2(C) — Use of solar altitude sight**

### H.3 Approximate method of determining solar altitude

In the absence of a solar altitude sight, the mid-winter solar altitude can be estimated by eye, using the fact that a closed fist extended at arm's length from the head subtends approximately  $10^\circ$  at the eye (see [Figure H.3](#)), as follows:

- (a) Select a viewpoint close to the lower edge of the collectors and face due north.
- (b) Extend one arm with the index finger in line between your eye and the true horizon.
- (c) Make a closed fist with your other hand and place it upright on top of the extended index finger; this gives a solar altitude of  $10^\circ$ .
- (d) Place the second fist on top of the first, which gives  $20^\circ$ , and so on. Then, using [Table H.1](#), estimate the altitude of the noon sun in mid-winter and note any likely shading.
- (e) Repeat this procedure facing N-E and N-W to estimate the mid-winter solar altitude at 9 am and 3 pm, respectively, using the data from [Table H.1](#).



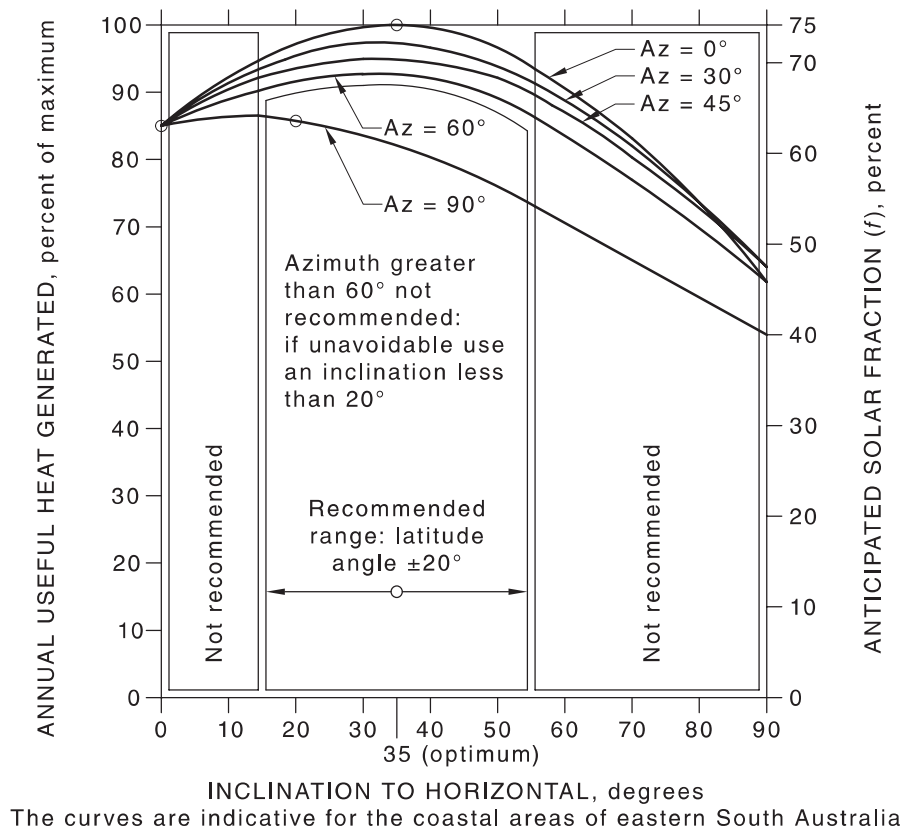
**Figure H.3 — “Fist” method of estimating solar altitude**

## Appendix I (informative)

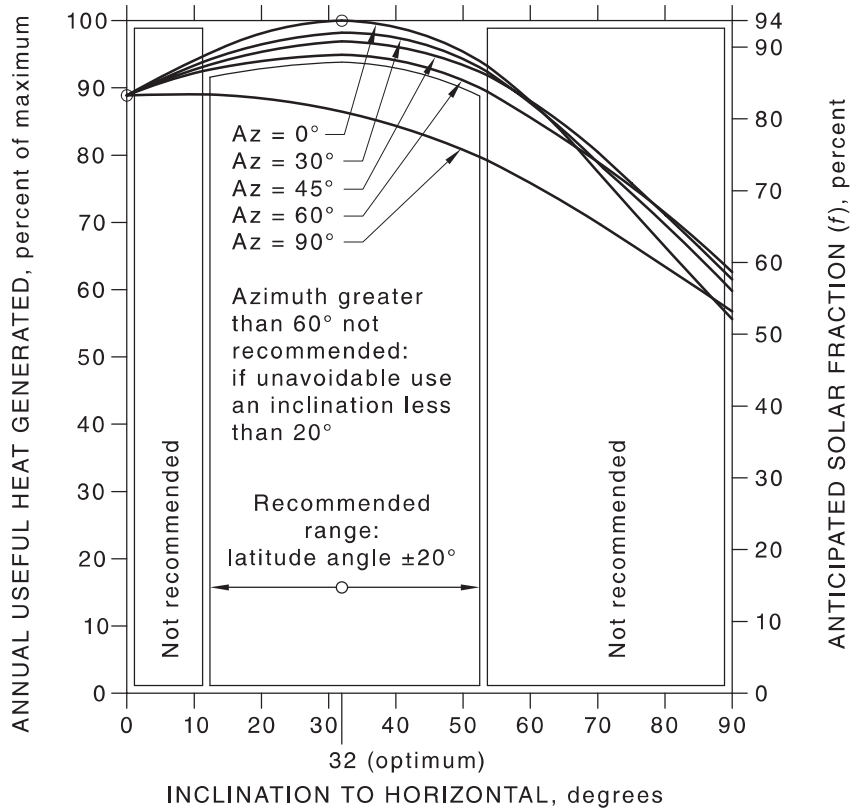
### Effect of inclination and orientation on system performance

This appendix provides a series of figures (Figures I.1 to I.9 for Australia, and Figures I.10 to I.13 for New Zealand) showing the effect on system performance of variations in collector inclinations for different orientations of the collector. The graphs were plotted using data generated by the “Sunbear” solar simulation program with radiation data appropriate for each area.

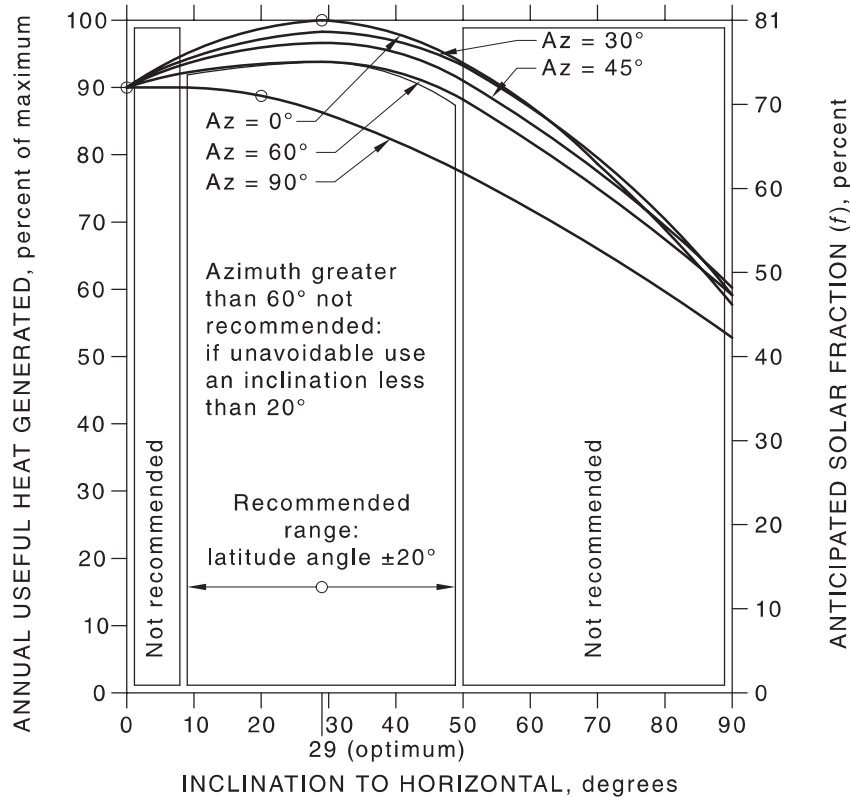
Figures are provided for a variety of locations and relate to the suggested component sizes for those locations given in Table G.1.



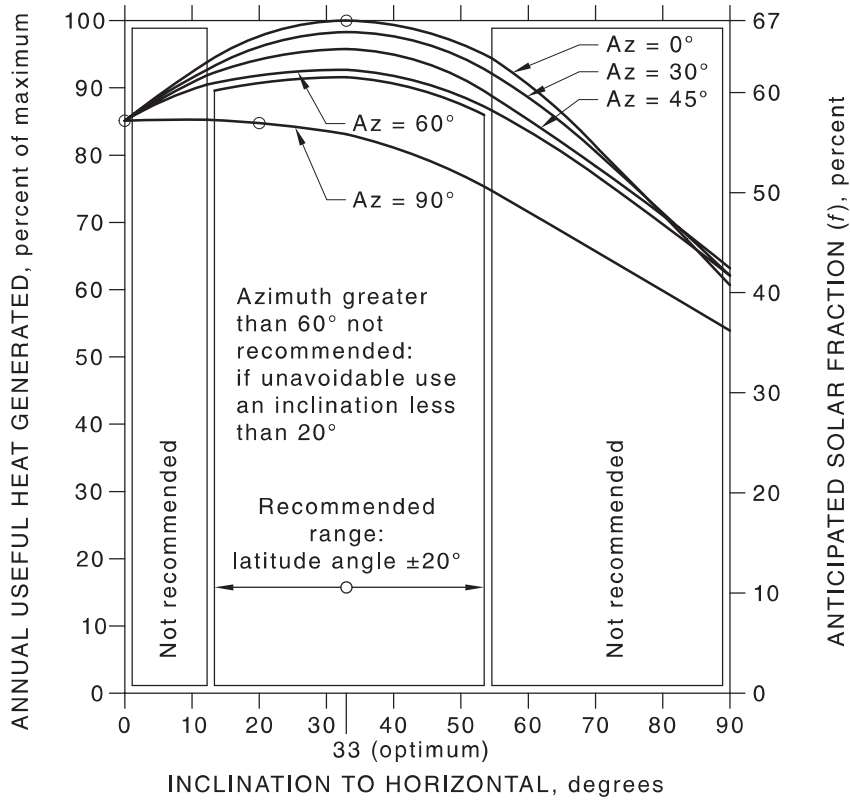
**Figure I.1 — Adelaide — Latitude 35°S**



**Figure I.2 — Alice Springs — Latitude 24°S**

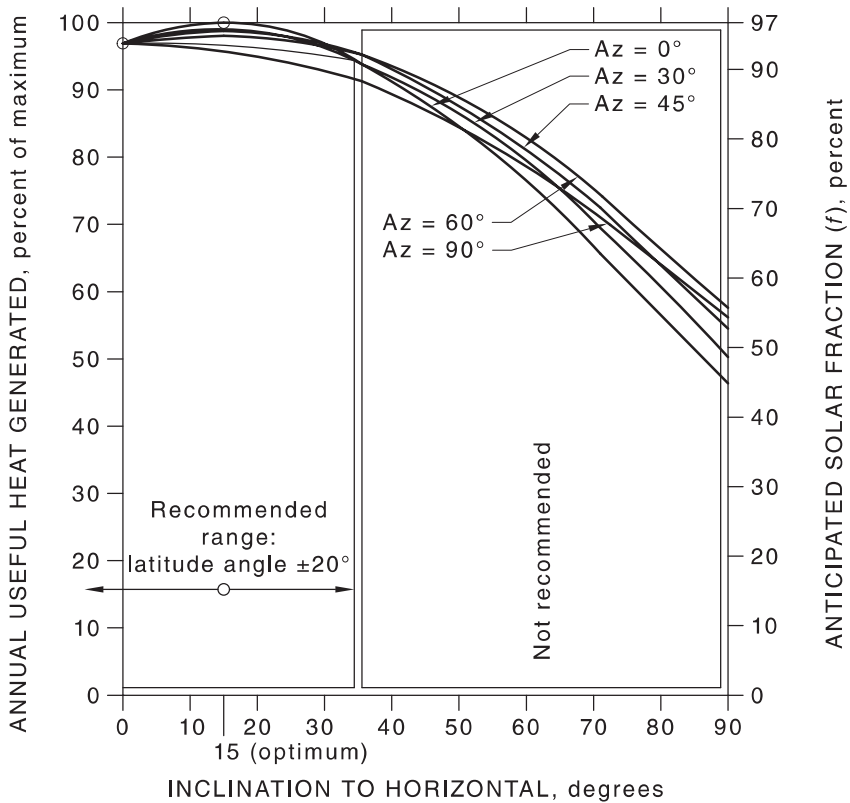


**Figure I.3 — Brisbane — Latitude 27°S**



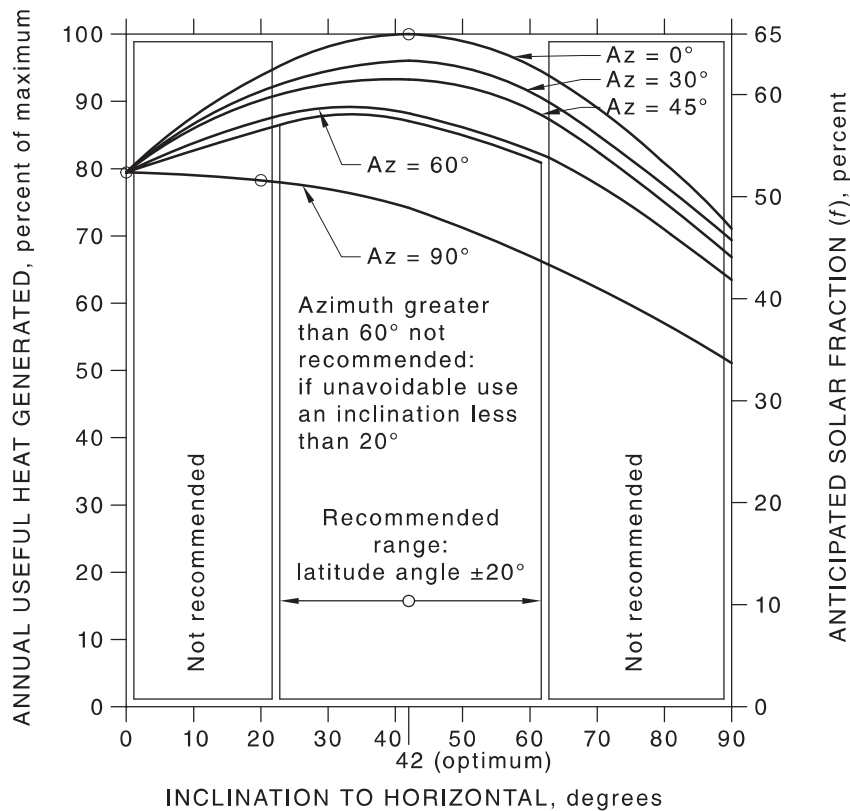
The curves are indicative for the highland areas of New South Wales, A.C.T. and Victoria

**Figure I.4 — Canberra — Latitude 35°S**

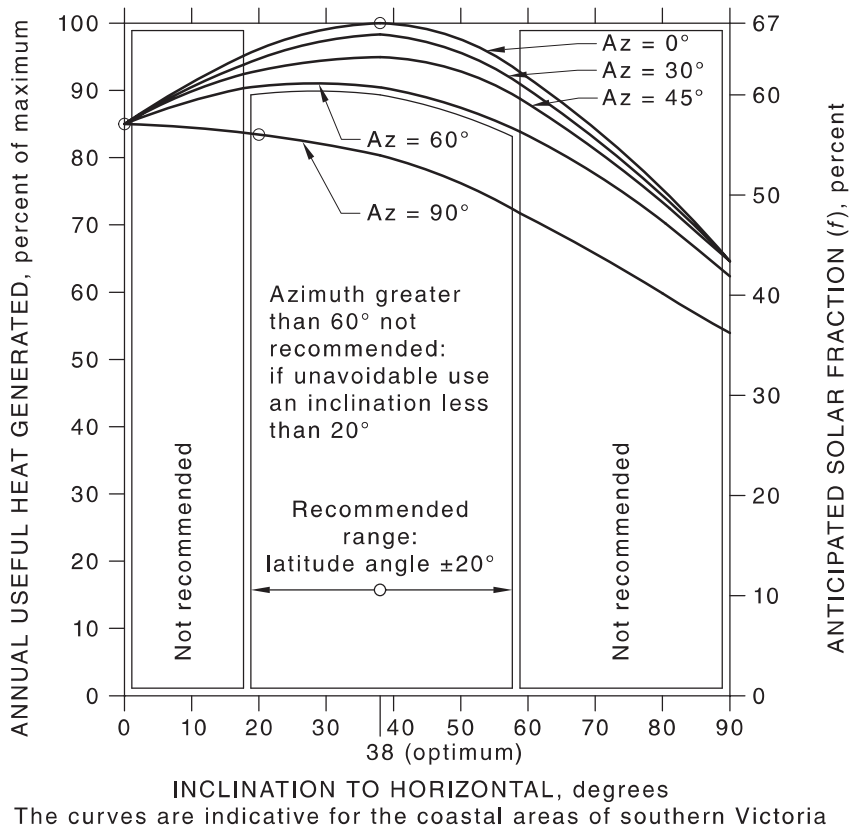


The curves are indicative for the coastal areas of northern (monsoonal) Australia

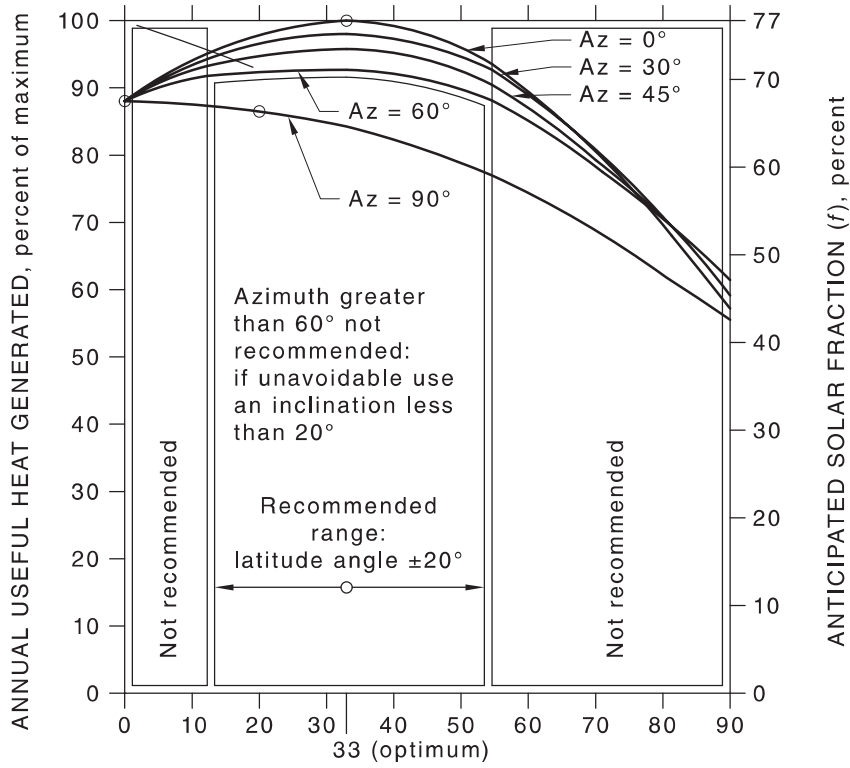
**Figure I.5 — Darwin — Latitude 12°S**



**Figure I.6 — Hobart — Latitude 43°S**

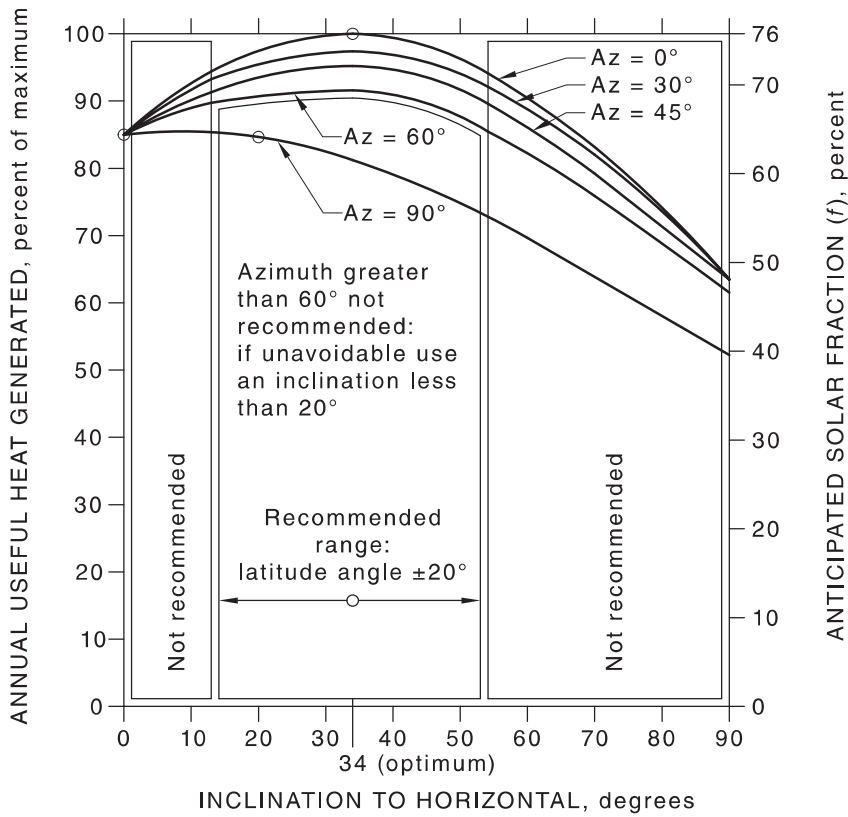


**Figure I.7 — Melbourne — Latitude 38°S**



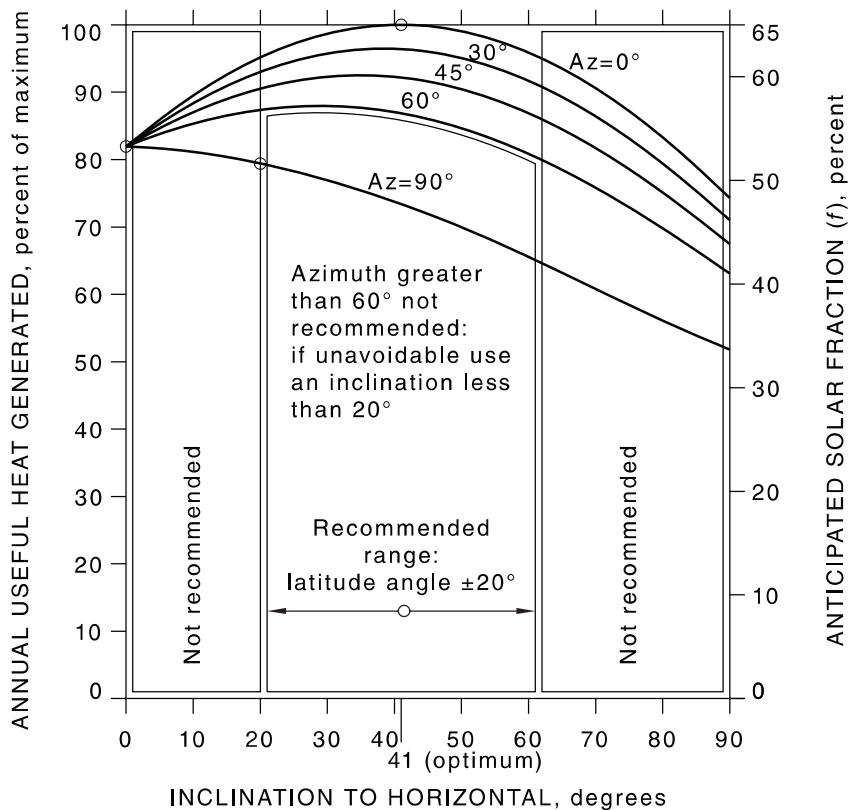
The curves are indicative for the coastal areas of southern Western Australia

**Figure I.8 — Perth — Latitude 32°S**



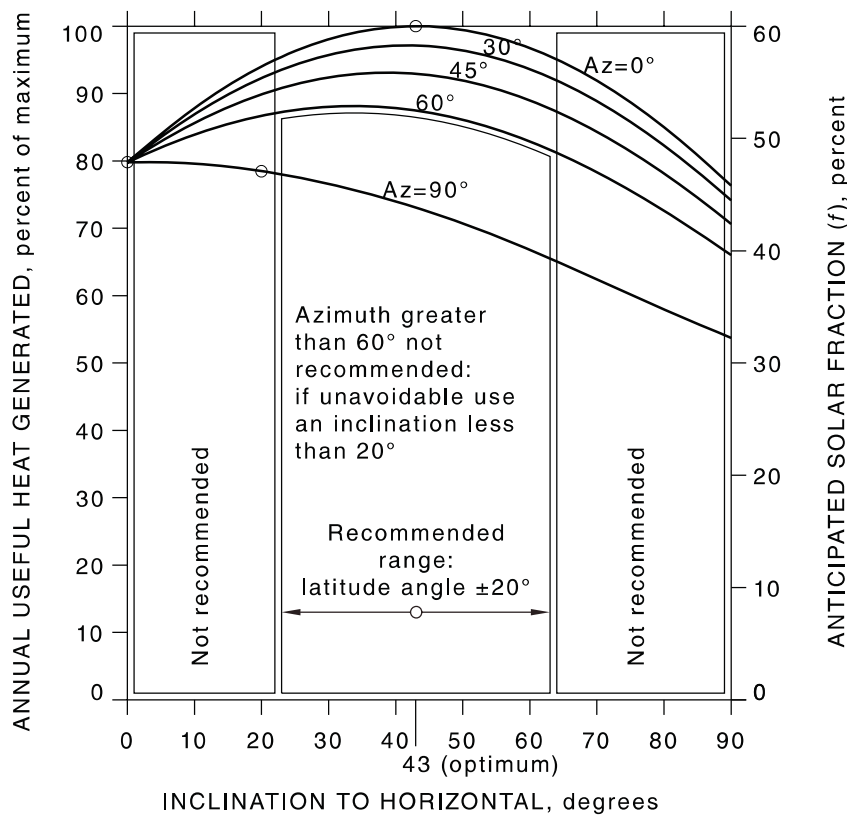
The curves are indicative for the coastal areas of New South Wales

**Figure I.9 — Sydney — Latitude 34°S**



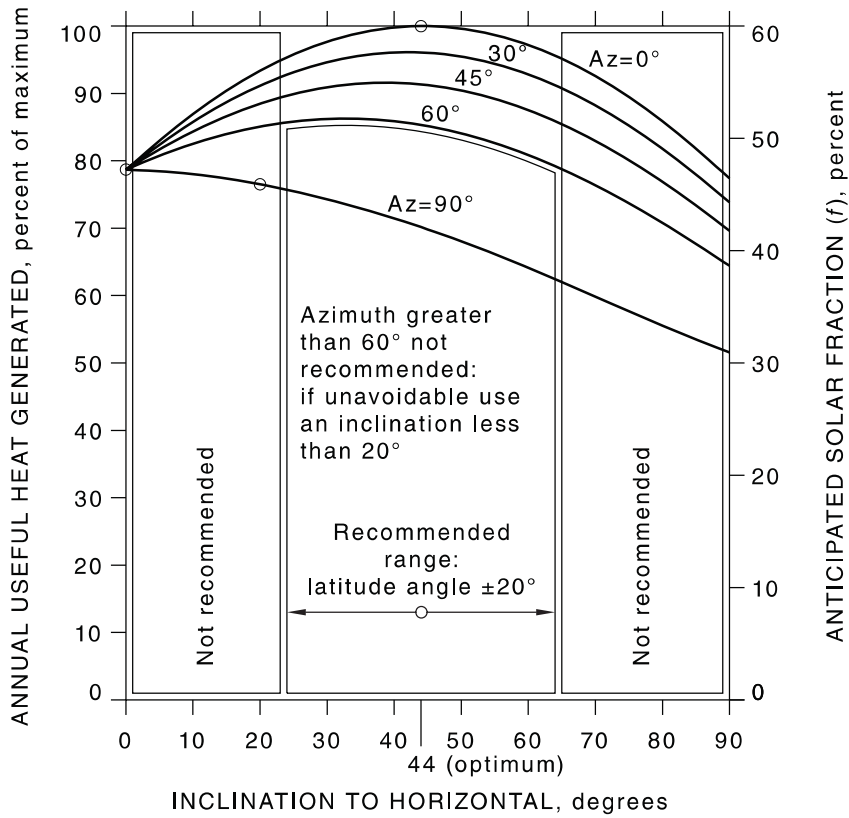
The curves are indicative for coastal areas of the northern North Island

**Figure I.10 — Auckland — Latitude 37°S**



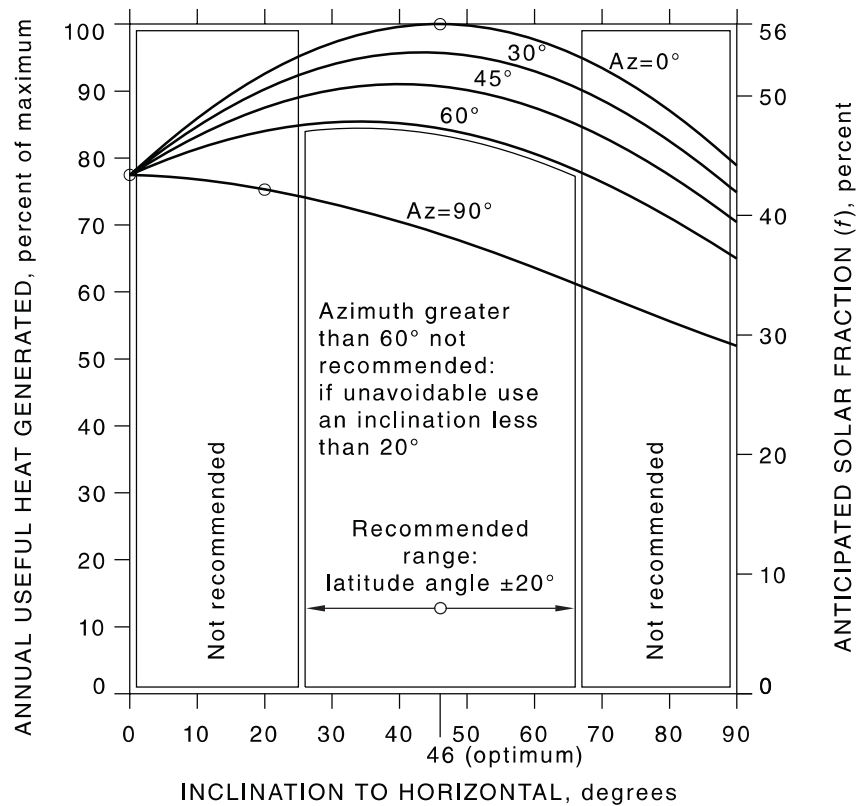
The curves are indicative for coastal areas of the southern North Island

**Figure I.11 — Wellington — Latitude 41°S**



The curves are indicative for coastal areas of the northern South Island

**Figure I.12 — Christchurch — Latitude 43.5°S**



The curves are indicative for coastal areas of the southern South Island

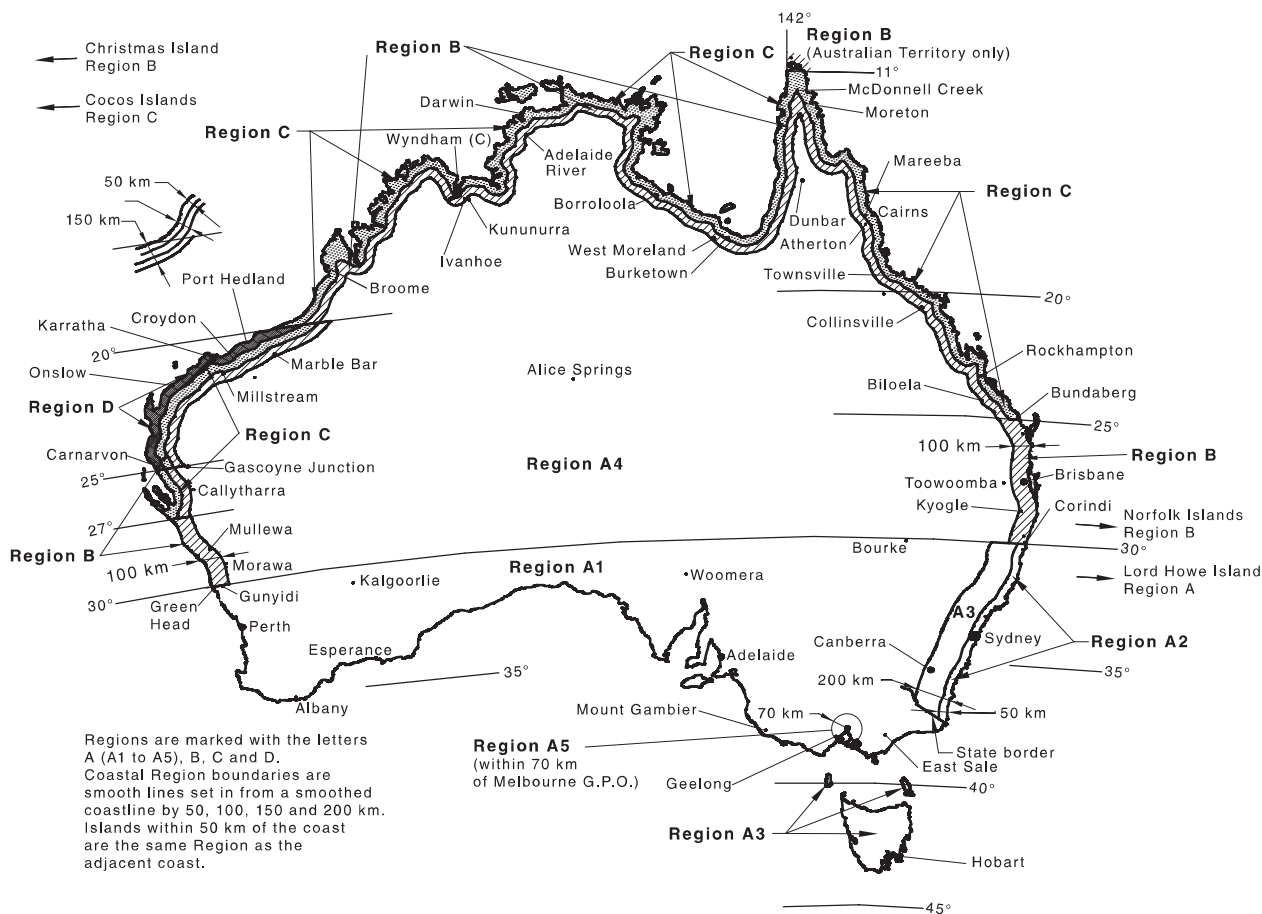
**Figure I.13 — Dunedin — Latitude 45.9°S**

## Appendix J (informative)

### Map of regional basic design wind speeds

Figures J.1 and J.2 are provided as a guide only to the nature of a locality with regard to basic wind speeds.

NOTE Refer to AS/NZS 1170.2 for information on the design of structures to withstand these wind velocities.



**Figure J.1 — Australian wind areas**

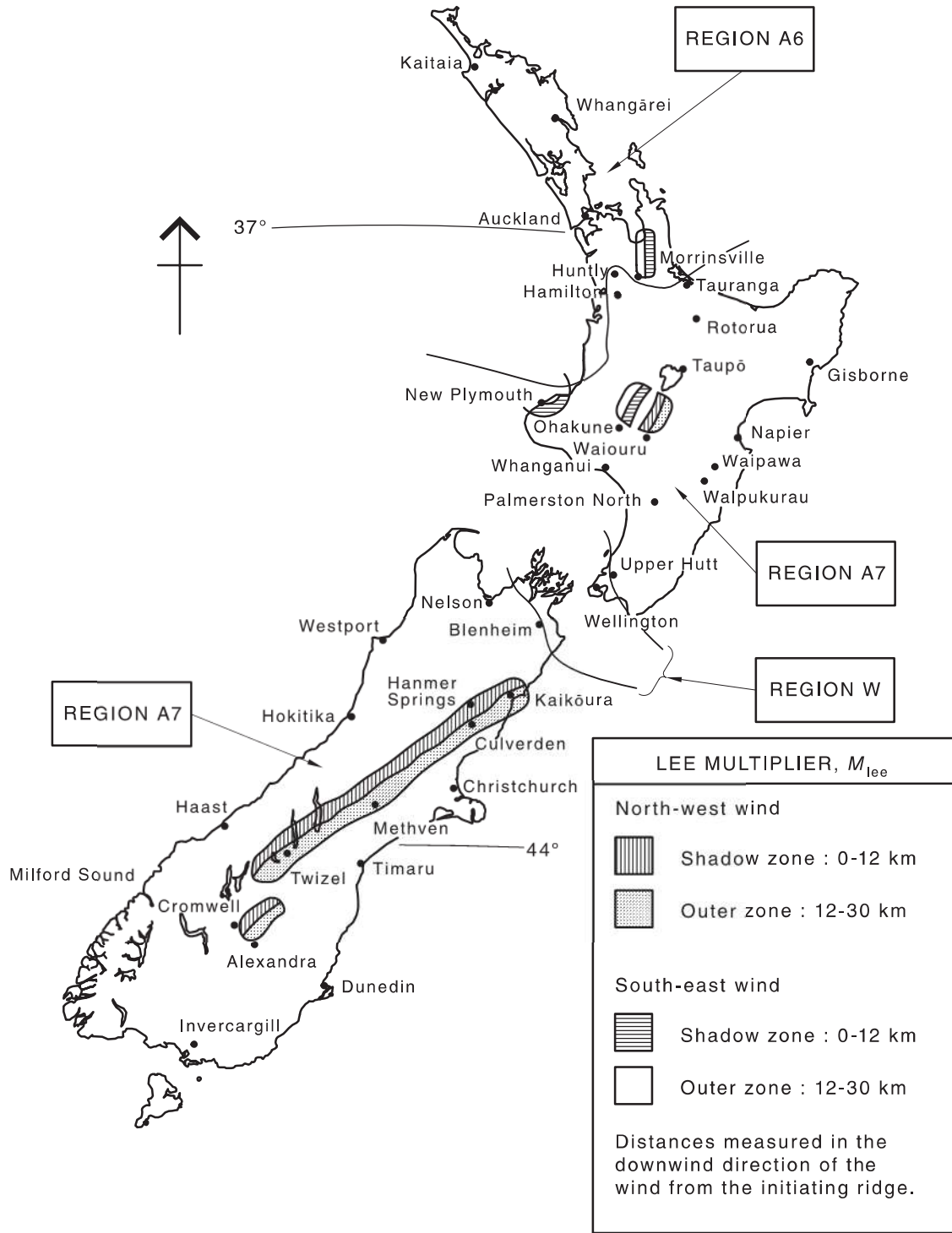


Figure J.2 — New Zealand wind areas

## Appendix K (normative)

### Australian climate regions

#### K.1 Scope

This appendix sets out the climate regions for Australia to define the requirements for energy efficiency.

#### K.2 Climate zones

The climate region boundaries shall be based on the climate zones given in the NCC.

NOTE Maps defining the NCC climate regions for each State and Territory are available on the ABCB website at <https://www.abcb.gov.au>. To view the various maps, enter the search string “climate zone”.

[Table K.1](#) provides the conversion from the NCC climate zones.

**Table K.1 — Climate regions and climate zones**

Climate region	NCC climate zone	Description
A	1	Hot and humid summer warm winter
	2	Warm and humid summer mild winter
	3	Hot and dry summer warm winter
	5	Warm temperate
B	4	Hot and dry summer cool winter
	6	Mild temperate
C	7	Cool temperate
	8	Alpine

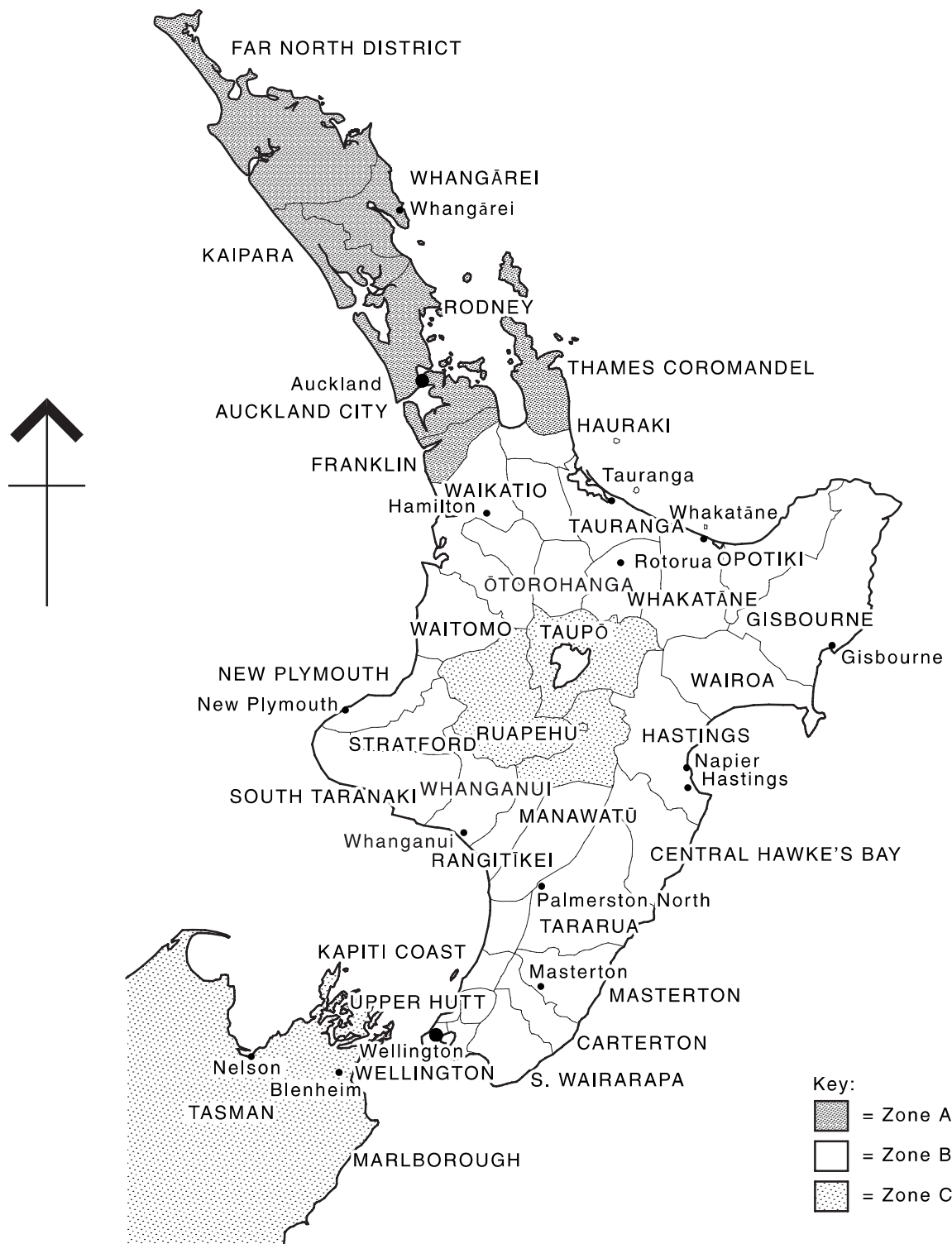
## Appendix L (normative)

### New Zealand climate regions

#### L.1 General

This appendix sets out the climate regions for New Zealand, as outlined in [Figure L.1](#), to define the requirements for energy efficiency.

The climate region boundaries shall be based on climatic data taking into account territorial authority boundaries, providing for three regions, see [Figure L.1](#).



**Figure L.1 — New Zealand climate regions**

## L.2 Climate regions

Region A comprises the Coromandel District, Franklin District and all districts north of these.

Region B comprises the remainder of the North Island excluding Taupō District, Ruapehu District and the northern part of the Rangitīkei District.

Region C comprises the remainder of the country, i.e. Taupō District, Ruapehu District, northern part of the Rangitīkei District, the South Island and all other islands not in Region A.

### L.3 Frost areas

Table L.3 shows the frost days throughout regions of New Zealand.

**Table L.3 — Frost days**

Location	Mean number of days of ground frost												
	Jan	Feb	Mar	Apr	May	Jun	Jul	Aug	Sep	Oct	Nov	Dec	Year
KAITAIA	0	0	0	0	0	0	0	0	0	0	0	0	1
WHANGĀREI	0	0	0	0	1	3	4	2	1	0	0	0	11
AUCKLAND	0	0	0	0	1	3	4	2	1	0	0	0	10
TAURANGA	0	0	0	1	5	9	12	9	4	2	1	0	42
ROTORUA	0	0	0	2	8	12	14	11	7	3	1	0	57
TAUPŌ	1	1	1	3	8	12	16	14	9	7	3	1	69
HAMILTON	0	0	1	3	8	11	14	11	7	3	1	0	63
NEW PLYMOUTH	0	0	0	0	1	4	4	3	1	0	0	0	15
MASTERTON	0	0	1	2	8	11	13	12	8	5	2	1	60
GISBORNE	0	0	0	0	3	8	9	8	3	1	0	0	33
NAPIER	0	0	0	0	3	7	7	7	3	1	0	0	29
PALMERSTON NORTH	0	0	0	1	4	8	10	8	4	2	1	0	38
WELLINGTON	0	0	0	0	1	2	3	3	1	0	0	0	10
WHANGANUI	0	0	0	0	0	1	3	2	0	0	0	0	7
WESTPORT	0	0	0	0	2	6	8	6	2	0	0	0	26
HOKITIKA	0	0	0	2	5	12	15	12	5	2	1	0	54
MILFORD SOUND	0	0	0	1	7	14	16	13	5	2	1	0	56
NELSON	0	0	1	4	12	18	21	17	10	4	1	0	88
BLenheim	0	0	0	1	6	15	16	13	6	2	0	0	60
KAIKŌURA	0	0	0	0	2	6	8	6	4	1	0	0	27
AORAKI/MOUNT COOK	1	1	3	9	19	22	24	23	14	8	3	1	140
CHRISTCHURCH	0	0	0	2	9	16	16	15	9	3	1	0	70
LAKE TEKAPO	1	1	5	11	21	25	27	25	16	9	5	3	149
TIMARU	0	0	2	5	12	21	23	19	12	5	3	0	100
DUNEDIN	0	0	0	2	6	13	16	12	7	3	1	0	58
QUEENSTOWN	0	0	1	5	13	21	24	21	14	7	3	0	107
ALEXANDRA	1	2	3	10	19	26	27	26	19	12	6	2	148
INVERCARGILL	1	2	3	6	9	16	18	16	11	6	4	2	94
CHATHAM ISLAND	0	0	0	0	0	1	1	1	1	0	0	0	4

NOTE Data are mean monthly values of the number of days with ground frosts for the 1971–2000 period for locations.

## Appendix M (informative)

### Operation and maintenance

#### M.1 Scope

This appendix provides guidelines for the operation and maintenance of a heated water system.

#### M.2 General

In order to ensure maximum performance and length of operation, water heaters should be inspected periodically.

#### M.3 Maintenance of heated water services

Heated water services should be maintained in accordance with the following:

- (a) *Water treatment units* — Where installed, water treatment units should be inspected periodically to ensure proper operation.
- (b) *Water vessels and tanks* — All vessels and tanks should be inspected and cleaned periodically, and in accordance with any requirements of the regulatory authority.

NOTE The frequency of periodic cleaning depends upon the quality of the supply water, design, materials of construction and the pipe system. Combinations of materials giving rise to corrosion should be avoided.

- (c) *Valves* — The following valves should be inspected periodically to ensure proper operation:
  - (i) Temperature/pressure-relief valves.
  - (ii) Expansion control valves.
  - (iii) Thermostatic mixing valves.
  - (iv) Tempering valves.
  - (v) Other associated valves/devices.
- (d) The requirements of AS/NZS 3666.2, where applicable.

## Appendix N (normative)

### Provision for expansion and contraction

#### N.1 Scope

This appendix sets out tables, formulae and calculations to allow for expansion and contraction in acceptable heated water pipes.

#### N.2 General

All materials used in plumbing services pipework experience length change due to the change in temperature.

If the pipework is locked into position and does not allow for thermal movement, related stress in the material will eventuate, which can cause premature failure.

The following problems can occur:

- (a) Failure of the piping from over-stressing, particularly at fabricated junctions or branches.
- (b) Leakage at location where the material has reached its stress point.
- (c) Distortion in the piping or connected equipment.

The design and installation of pipework material shall take into consideration each material type, the method of installation and the change in temperature.

Thermal length changes shall be calculated based on the difference between the coldest temperature in the pipework (i.e. during installation of the system or when the system is not in operation) and the highest temperature during operation.

#### N.3 Calculating thermal length change

To calculate the thermal length change of a pipe section, the following equation shall be used for a range of temperature differentials:

$$X = L \times (T_2 - T_1) \times \alpha \quad \text{N.3}$$

where

- $X$  = thermal length change, in millimetres (mm)
- $L$  = length of pipe section, in metres (m)
- $T_1$  = coldest temperature, in degrees centigrade (°C)
- $T_2$  = highest temperature, in degrees centigrade (°C)
- $\alpha$  = coefficient of thermal expansion (mm/(m\*K), see [Table N.3\(A\)](#))

**Table N.3(A) — Coefficients of thermal expansion for common pipe materials ( $\alpha$ )**

Metals		Plastics	
Materials	Coefficient $\alpha$ mm/(m*K)	Materials	Coefficient $\alpha$ mm/(m*K)
Copper	0.0177	PE-X	0.15
Stainless Steel	0.0159	PB	0.13
		PP-R	0.15
		PE-X/Al/PE-X and PE-X/Al/PE	0.02

NOTE For some constructions of multi-layer pipes or composite pipes there are different values of  $\alpha$ .

**Table N.3(B) — Rates of thermal expansion for common pipe materials, mm/m**

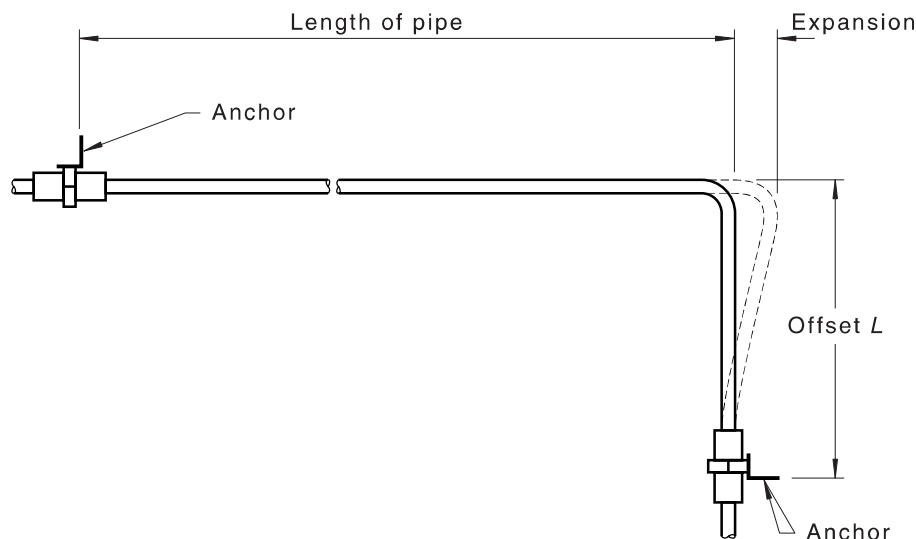
Change in temperature, °C	Copper	Stainless steel	PE-X	PB	PP-R	PE-X/Al/PE-X and PE-X/Al/PE
10	0.18	0.16	1.5	1.3	1.5	0.2
20	0.35	0.32	3.0	2.6	3.0	0.4
30	0.53	0.48	4.5	3.9	4.5	0.6
40	0.71	0.64	6.0	5.2	6.0	0.8
50	0.89	0.80	7.5	6.5	7.5	1.0
60	1.06	0.95	9.0	7.8	9.0	1.2
70	1.24	1.11	10.5	9.1	10.5	1.4
80	1.42	1.27	12.0	10.4	12.0	1.6
90	1.59	1.43				
100	1.77	1.59				

NOTE [Table N.3\(B\)](#) shows expansion in length per metre run of pipe for selected temperature increases.

## N.4 Provision for expansion

Provisions for expansion shall be included when designing pipe runs and fixing points, by allowing freedom of movement at bends, branches and tees.

The most common method of accommodating expansion is to provide an offset or change in direction and allowing the pipe to move. For this type of provision, the pipe shall not be fixed within the offset distance of the end as shown in [Figure N.4](#).



**Figure N.4 — Offset to accommodate expansion**

This figure is reproduced [with modification] with permission from the International Copper Association Australia.

### N.5 Calculating the offset length

The length of the offset ( $L_{\text{Offset}}$ ) shall be calculated from the following equation:

$$L_{\text{Offset}} = C \times \sqrt{d \times X} \tag{N.5}$$

where

- $L_{\text{Offset}}$  = offset length, in millimetres (mm)
- $C$  = material constant in accordance with [Table N.5](#)
- $d$  = pipe outer diameter, in millimetres (mm)
- $X$  = expansion or thermal length change as determined by [Equation N.3](#), in millimetres (mm) or from [Table N.3\(B\)](#)

NOTE The length of pipe section ( $L$ ) is the length between the anchor point and the offset bend.

The calculated values shall be rounded up to the next 5 mm step.

Different materials require different offset allowances due to their physical properties.

**Table N.5 — Values of material constant ( $C$ )**

Material	$C$
Copper, stainless steel	61.2
PE-X	12
PB	10
PP-R	20
PVC-C	34
PE-X/Al/PE-X and PE-X/Al/PE	30

**Table N.5** (continued)

Material	C
NOTE For some constructions or composite pipes there are different values of C.	

**N.5.1 Example 1**

A 6 m length of DN 50 hot water copper pipe experiences a temperature change of 50 °C. The copper pipe is fixed at one end and has a 90° elbow on the other. What is the offset length required to provide allowance for thermal expansion and contraction?

From [Table N.3\(B\)](#) the 6 m length of copper tube will expand  $6 \times 0.89 \text{ mm} = 5.34 \text{ mm}$

Alternatively, from [Equation N.3](#):

$$X = L \times (T_2 - T_1) \times \alpha$$

$$X = 6 \times 50 \times 0.0177 = 5.31 \text{ mm}$$

From [Equation N.5](#):

$$L_{\text{Offset}} = C \times \sqrt{d \times X}$$

$$L_{\text{Offset}} = 61.2 \times \sqrt{(50.8 \times 5.34)}$$

$$L_{\text{Offset}} = 1\,005 \text{ mm}$$

**N.5.2 Example 2**

A 14 m length of hot water PE-X pipe DN 50 (OD 63 mm) experiences a temperature change of 50 °C. The PE-X pipe is fixed at one end and has a 90° elbow on the other. What is the offset length required to provide allowance for thermal expansion and contraction?

From [Table N.3\(B\)](#) the 14 m length of PE-X pipe will expand  $14 \times 7.5 \text{ mm} = 105 \text{ mm}$

Alternatively, from [Equation N.3](#):

$$X = L \times (T_2 - T_1) \times \alpha$$

$$X = 14 \times 50 \times 0.15 = 105 \text{ mm}$$

From [Equation N.5](#):

$$L_{\text{Offset}} = C \times \sqrt{d \times X}$$

$$L_{\text{Offset}} = 12 \times \sqrt{(63 \times 105)}$$

$$L_{\text{Offset}} = 980 \text{ mm}$$

**N.6 Offsets in bends with two anchor points**

A change in direction may be used to accommodate the thermal length changes from two directions. In this case, offsets shall be provided on both sides of the bend. The combined length of both offsets shall not exceed the maximum spacing distance of brackets and clips in accordance with [Table 4.5.4](#).

NOTE [Figure N.6](#) shows an offset to accommodate expansion in two directions.

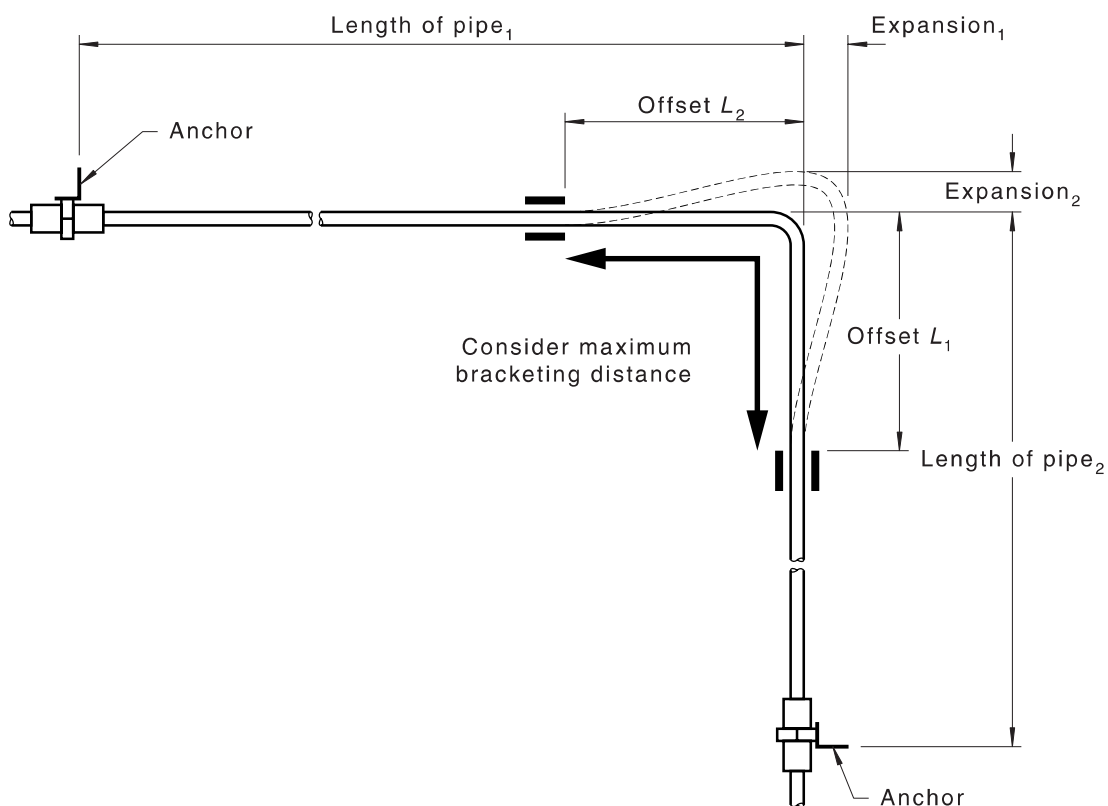


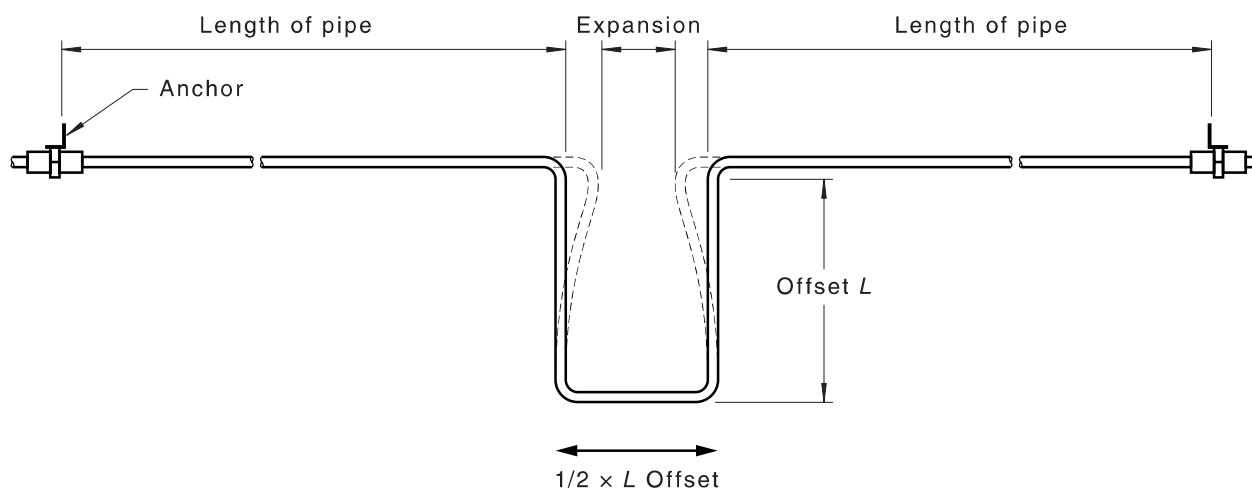
Figure N.6 — Offset to accommodate expansion from two directions

## N.7 Expansion loops

Long pipe sections may need to be split up in sub-sections by installing more than one anchor point. Between any two anchor points, a provision for thermal movement shall be created by installing an expansion loop, U-bend or expansion joints.

Expansion loops and U-bends shall be located near the centre of the length of pipe and placed horizontally, to avoid formation of water troughs in or between two expansion loops where the water stagnates when the system is drained and to avoid forming air locks at the top of the loops.

NOTE [Figure N.7](#) shows an expansion loop.



NOTE The length of pipe ( $L$ ) is the length between the anchor point and the offset bend.

**Figure N.7 — Expansion loop**

## N.8 Calculating the offset length for an expansion loop or U-bend

Because the expansion loop or U-bend consists of two offsets back to back, half of the expansion will be accommodated by each side of the U-bend. Therefore, when using [Equation N.5](#), the expansion or thermal length change ( $X$ ) shall be half of the expansion that the entire length of pipe experiences.

### N.8.1 Example 3

A 6-storey building has an 18 m stainless steel hot water riser pipe DN 50 (OD 54 mm) to a storage tank at the top of the building that can experience a temperature change of 50 °C. The stainless-steel riser is fixed at both ends, but provision has been made for a horizontal expansion loop to be placed between the middle floors of the building. What is the offset length for the expansion loop in order to provide allowance for thermal expansion and contraction?

From [Table N.3\(B\)](#) the 18 m length of stainless-steel pipe will expand a total of  $18 \times 0.80 \text{ mm} = 14.34 \text{ mm}$

Alternatively, from [Equation N.3](#):

$$X = L \times (T_2 - T_1) \times \alpha$$

$$X = 18 \times 50 \times 0.0159 = 14.31 \text{ mm}$$

Half of this expansion will be accommodated by each side of the expansion loop so half of this expansion distance (7.17 mm) is used when the offset is calculated in [Equation N.5](#).

From [Equation N.5](#):

$$L_{\text{Offset}} = C \times \sqrt{(d \times X)}$$

$$L_{\text{Offset}} = 61.2 \times \sqrt{(54 \times 7.17)}$$

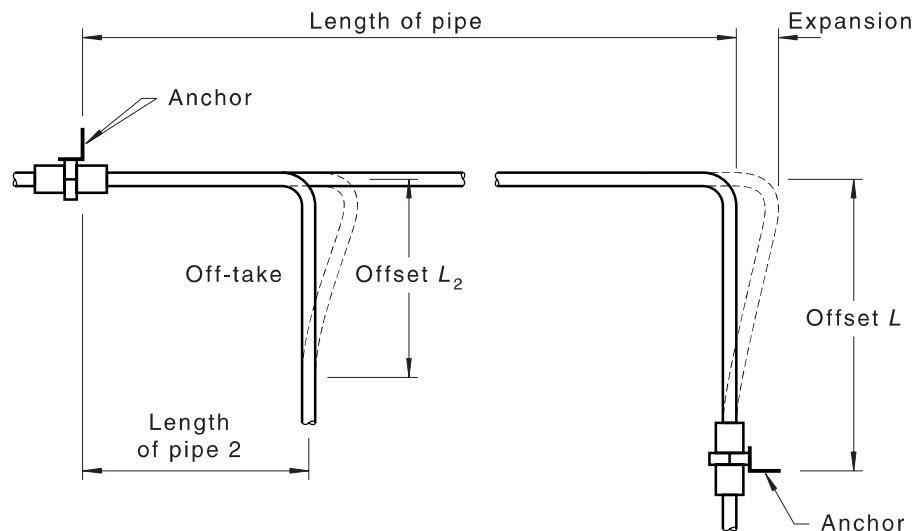
$$L_{\text{Offset}} = 1\,205 \text{ mm}$$

## N.9 Branch off-takes

Branch off-takes from hot water pipes require an offset  $L$  to accommodate thermal length changes of the main pipe. Within the offset length movement of the branch off-take shall not be restricted by brackets, floors, walls or other services.

Offset  $L_2$  shall be calculated using [Equations N.3](#) and [N.5](#). The thermal length change shall be calculated using the length of pipe between anchor point and branch off-take. The required offset length shall be calculated based on the outer diameter of the branch off-take.

NOTE [Figure N.9](#) shows expansion offset for branch off-take.



**Figure N.9 — Expansion offset for branch off-take**

### N.9.1 Example 4

As an extension of Example 1 for a DN 50 hot water copper pipe, there is now a DN 25 (OD 25.4) branch off-take 4 m from the nearest anchor point. What is the offset length required in the branch off-take to provide allowance for thermal expansion and contraction in the main line?

From [Table N.3\(B\)](#) the 4 m length of copper tube will expand  $4 \times 0.89 \text{ mm} = 3.56 \text{ mm}$

Alternatively, from [Equation N.3](#):

$$X = L \times (T_2 - T_1) \times \alpha$$

$$X = 4 \times 50 \times 0.00177 = 3.54 \text{ mm}$$

From [Equation N.5](#):

$$L_{\text{Offset}} = C \times \sqrt{(d \times X)}$$

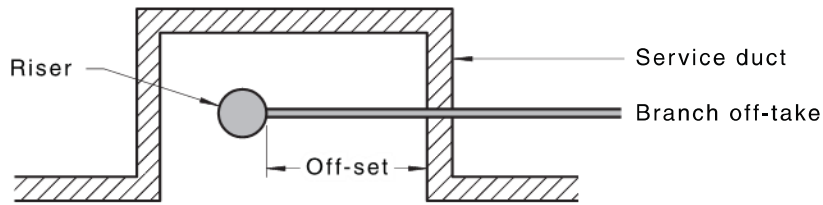
$$L_{\text{Offset}} = 61.2 \times \sqrt{(25.4 \times 3.56)}$$

$$L_{\text{Offset}} = 585 \text{ mm}$$

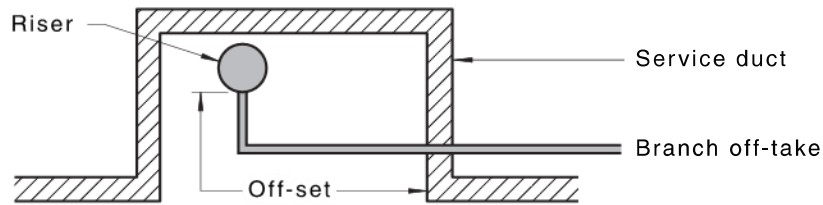
### N.10 Branch off-takes in ducts

Movement of branch off-takes in ducts shall not be restricted by brackets, floors, walls or other services within the offset length. Offsets shall be installed straight or bent. Bent off-takes provide for a longer offset distance.

NOTE [Figure N.10](#) shows examples of straight and bent installations of branch offsets in ducts.



a) Straight off-set in duct — Plan view



b) Bent off-set in duct — Plan view

NOTE Additional clearance may be provided for expansion where the pipe passes through the wall of the service duct provided it does not contravene fire regulations

**Figure N.10 — Examples of expansion offsets in ducts**

## Appendix O (informative)

### Estimation of probable simultaneous demand for residential buildings from the total of loading units

**Table O.1 — Probable simultaneous demand for a circulatory heated water system in residential buildings**

No. of loading units	Flow rate L/s	No. of loading units	Flow rate L/s	No. of loading units	Flow rate L/s
100	1.20	650	2.75	1 800	4.90
150	1.35	700	2.85	2 000	5.25
200	1.45	750	2.95	2 200	5.50
250	1.60	800	3.05	2 400	5.75
300	1.70	850	3.20	2 600	6.00
350	1.85	900	3.30	2 800	6.35
400	2.00	950	3.40	3 000	6.70
450	2.15	1 000	3.50	3 500	7.25
500	2.35	1 200	3.80	4 000	7.75
550	2.50	1 400	4.20	4 500	8.40
600	2.60	1 600	4.60	5 000	9.00

## Appendix P (normative)

### Sizing of expansion vessels in mains pressure systems

This appendix sets out a method to calculate expansion vessel volume in mains pressure systems, as follows:

- (a) Calculate the expanded water volume ( $V_{\text{expanded}}$ ):

$$V_{\text{expanded}} = \text{TSV} \times \text{EF} \quad \text{P.1}$$

where

TSV = total system volume, in litres:

The total volume of all heated water in the system including water heaters and storage tanks. Where the temperature in dead leg branch lines is not maintained, for example, not heat traced, the volume of water contained in the branch lines may be excluded.

EF = water expansion factor:

The water expansion factor is the amount that water will expand per litre when heated from its coldest to hottest temperature, as given in [Table P.1](#).

- (b) Calculate the maximum allowed system pressure ( $P_{\text{high}}$ ) (kPa):

$$P_{\text{high}} = 0.85 \times P_{\text{max}} \quad \text{P.2}$$

where

$P_{\text{max}}$  = temperature/pressure-relief valve or pressure-relief valve setting, in kilopascals: the lowest relief valve setting of all relief valves in a system (e.g. a water heater may have a pressure-relief valve setting of 850 kPa and the storage tank may have a temperature/pressure relief valve setting of 1 000 kPa;  $P_{\text{max}}$  would be 850 kPa).

- (c) Determine the water supply pressure ( $P_{\text{low}}$ ) (kPa).

where

$P_{\text{low}}$  = water supply pressure, in kilopascals:

The water supply pressure is the maximum water supply pressure to the system. This will be the pre-charge pressure that the expansion vessel will need to be set at.

- (d) Calculate the acceptance factor (AF):

$$\text{AF} = (P_{\text{high}} - P_{\text{low}}) / (P_{\text{high}} + 100 \text{ kPa}) \quad \text{P.3}$$

If the AF is greater than 0.5, use 0.5.

- (e) Calculate the total tank volume ( $L$ ).

$$L = V_{\text{expanded}} / \text{AF} \quad \text{P.4}$$

- (f) Select a tank with equal or greater volume than that calculated.
- (g) Pre-charge the expansion vessel to the pressure determined in (c) above.

**EXAMPLE** A building is serviced by a gas water heater and a storage tank with a storage capacity of 325 L. The flow and return circuit is to be run in Type B copper and the sum of all flow lines is 45 m of diameter 40 mm pipe and the return line is 12 m of diameter 25 mm pipe. The temperature in the branch lines is not maintained. The system is supplied with heated water at 65 °C and the coldest water temperature in winter is 10 °C. Incoming supply pressure to the building is 500 kPa.

- 1 Determine the total system volume (TSV).

From supplier tables it is determined that the total volume of fluid in the pipework is 50 L. The storage tank volume is 325 L. Checking with the supplier, it is determined the water heater volume is relatively small, and an allowance of 10 L is to be made.

Therefore  $TSV = 50 + 325 + 10 = 385$  L.

- 2 Determine the expansion factor (EF).

Hot temperature = 65 °C, cold temperature = 10 °C. From [Table P.1](#), 65 °C is not shown. Use 70 °C hot and cross reference against 10 °C cold.

$$EF = 0.0201$$

- 3 Calculate the expanded water volume.

$$V_{\text{expanded}} = 385 \times 0.0201 = 7.74 \text{ L}$$

- 4 Calculate the maximum allowed system pressure ( $P_{\text{high}}$ ).

From supplier literature or rating plate data, the water heater relief valve setting is 850 kPa and the storage tank is 1 000 kPa. Therefore use 850 kPa.

$$P_{\text{high}} = 0.85 \times 850 = 723 \text{ kPa.}$$

- 5 Determine water supply pressure ( $P_{\text{low}}$ ).

Given as 500 kPa.

- 6 Calculate the AF.

$$AF = (P_{\text{high}} - P_{\text{low}}) / (P_{\text{high}} + 100 \text{ kPa}).$$

$$AF = (723 - 500) / (723 + 100) = 0.27. \text{ As this is less than 0.5, use 0.27.}$$

- 7 Calculate the total tank volume.

$$\text{Total tank volume (L)} = 7.74 / 0.27 = 28.7 \text{ L.}$$

- 8 Select a tank with a capacity at least 29 L.

- 9 Pre-charge the expansion tank to a pressure of 500 kPa.

**Table P.1 — Water expansion factor (EF)**

Expansion of 1 L of water when raised from T1 (cold) to T2 (hot)											
		T2 (Hot), °C									
		4	10	20	30	40	50	60	70	80	90
T1 (Cold) °C	4	0	0.0003	0.0018	0.0043	0.0078	0.0121	0.0171	0.0227	0.0290	0.0356
	10		0	0.0015	0.0041	0.0075	0.0118	0.0168	0.0224	0.0287	0.0356
	20			0	0.0026	0.0060	0.0103	0.0153	0.0209	0.0272	0.0340
	30				0	0.0035	0.0077	0.0127	0.0183	0.0245	0.0314
	40					0	0.0042	0.0092	0.0148	0.0210	0.0278
	50						0	0.0049	0.0105	0.0167	0.0235
	60							0	0.0055	0.0117	0.0185
	70								0	0.0061	0.0129
	80									0	0.0067
90										0	

NOTE 1 Volumetric capacity of pipes are given in [Table Q.2](#).

NOTE 2 See [Appendix Q](#) for a guide to determine capacity of dead legs and estimating wait times.

NOTE 3 Dead legs with volumetric capacity exceeding 2 L may require additional water heaters or trace heating.

NOTE 4 See [Table 8.2.2](#) for pipe insulation requirements.

## Appendix Q (informative)

### Sizing of branches from circulatory heated water systems

#### Q.1 Scope

This appendix provides guidelines for sizing branch piping and estimating wait times for delivery of heated water using internal diameter and volume of acceptable heated water pipes.

#### Q.2 General

The volume of acceptable pipes is given in [Table Q.2](#).

**Table Q.2 — Volume of pipes**

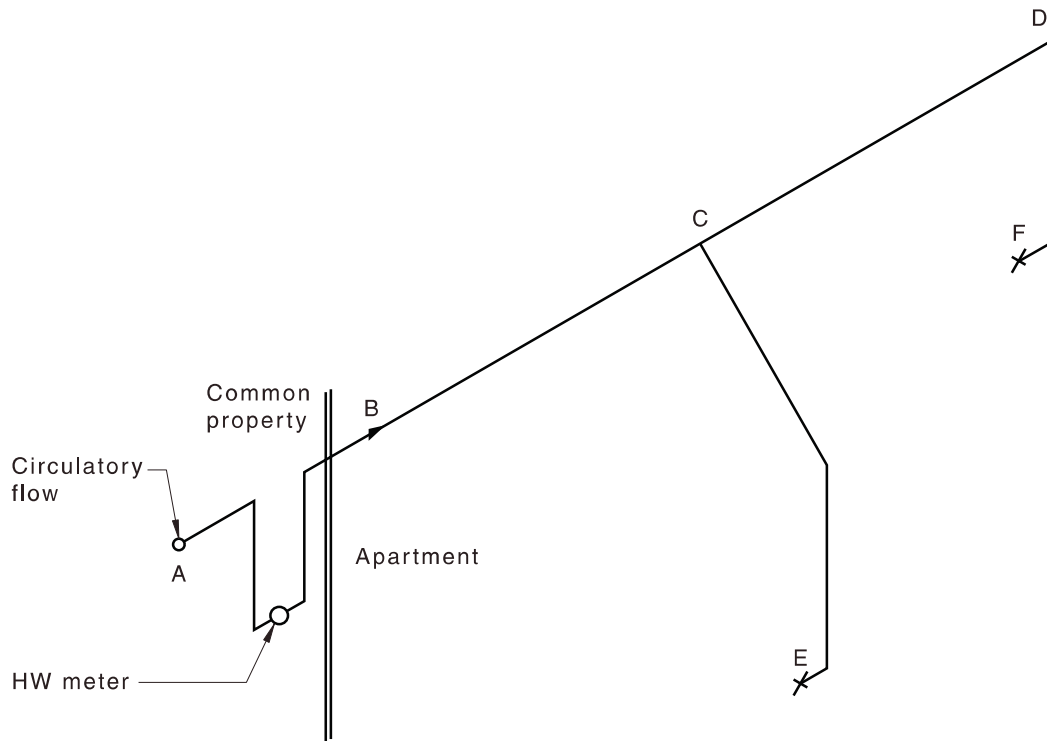
Specified nominal size DN	Litres per metre					
	Copper		Stainless steel EN 10312 Series 2	PB SDR 11	PE-X SDR 9	PP-R SDR 7.4
	AS 1432 Type B	NZS 3501:1976 Table 1				
10	0.047	0.071	–	–	–	–
15	0.093	0.127	0.133	–	–	–
16	–	–	–	0.135	0.119	0.111
18	0.150	–	0.201	–	–	–
20	0.227	0.284	0.302	0.214	0.194	0.170
25	–	–	–	0.337	0.305	0.263

NOTE Capacity of pipes are calculated from internal diameters shown in [Tables C.1, C.2](#) and [C.3](#).

#### Q.3 Worked example

A worked example showing the calculations using pipe volumes to design dead legs that include a flow meter for a typical apartment, dwelling or secure area is shown in [Figure Q.3](#).

NOTE For dead leg branches serving individual or small groups of outlets without metering, the heated water circulatory flow should be located as close as practicable to each individual or small group of outlets so as to reduce the length of each branch, see [Clause 10.9.2](#) for location of circulatory piping.



Pipe section details				Dead legs			Time to drain cooled water	
Section	Pipe	Length	Litres	Sections	Length	Litres	@ 9 L/m	@ 6 L/m
A-B	DN20Cu	3.3 m	0.75	A-B-C-D-F	13.7 m	1.99	13.26 s	19.9 s
B-C	DN16PE-X	3.5 m	0.42	A-B-C-E	11.1 m	1.69	11.27 s	16.9 s
C-D	DN16PE-X	4.6 m	0.55					
C-E	DN16PE-X	4.3 m	0.52					
D-F	DN16PE-X	2.3 m	0.27					

NOTE Pipe materials are indicative only. See [Table Q.2](#) to calculate volumes for other acceptable pipes.

**Figure Q.3 — Example showing two of the outlets in a typical apartment**

## Bibliography

- AS 1345, *Identification of the contents of pipes, conduits and ducts*
- AS 1357 (all parts), *Valves primarily for use in heated water systems*
- AS 1361, *Electric heat-exchange water heaters—For domestic applications*
- AS 1379, *Specification and supply of concrete*
- AS 1397, *Continuous hot-dip metallic coated steel sheet and strip—Coatings of zinc and zinc alloyed with aluminium and magnesium*
- AS 1478.1, *Chemical admixtures for concrete, mortar and grout, Part 1: Admixtures for concrete*
- AS 1646, *Elastomeric seals for waterworks purposes*
- AS 1910, *Water supply—Float control valves for use in hot and cold water*
- AS 2129, *Flanges for pipes, valves and fittings*
- AS 2239, *Galvanic (sacrificial) anodes for cathodic protection*
- AS 3600, *Concrete structures*
- AS 3688, *Water supply and gas systems—Metallic fittings and end connectors*
- AS 4032.1, *Water supply—Valves for the control of heated water supply temperatures, Part 1: Thermostatic mixing valves—Materials design and performance requirements*
- AS 4176 (all parts), *Multilayer pipes for pressure applications*
- AS 5082.1, *Polybutylene (PB) plumbing pipe systems—Metric series, Part 1: Metric polybutylene (PB) pipes for hot and cold water applications*
- AS 5082.2, *Polybutylene (PB) plumbing pipe systems—Metric series, Part 2: Mechanical and fusion jointing systems*
- AS 5200.053, *Plumbing and drainage products, Part 053: Stainless steel pipes and tubes for pressure applications*
- AS/NZS 1167.1, *Welding and brazing—Filler metals, Part 1: Filler metal for brazing and braze welding*
- AS/NZS 1167.2, *Welding and brazing—Filler metals, Part 2: Filler metal for welding*
- AS/NZS 1170.2, *Structural design actions, Part 2: Wind actions*
- AS/NZS 1604 (all parts), *Specifications for preservative treatment*
- AS/NZS 2280, *Ductile iron pipes and fittings*
- AS/NZS 2492, *Cross-linked polyethylene (PE-X) pipes for pressure applications*
- AS/NZS 2537 (all parts), *Mechanical jointing fittings for use with crosslinked polyethylene (PE-X) for pressure applications*
- AS/NZS 2544, *Grey iron pressure fittings*
- AS/NZS 2642 2, *Polybutylene (PB) plumbing pipe systems, Part 2: Polybutylene (PB) pipe for hot and cold water applications*

AS/NZS 2642.3, *Polybutylene (PB) plumbing pipe systems, Part 3: Mechanical jointing fittings for use with polybutylene (PB) pipes for hot and cold water applications*

AS/NZS 2712, *Solar and heat pump water heaters—Design and construction*

AS/NZS 2878, *Timber—Classification into strength groups*

AS/NZS 3666.2, *Air-handling and water systems of buildings—Microbial control, Part 2: Operation and maintenance*

AS/NZS 4020, *Testing of products for use in contact with drinking water*

AS/NZS 4331 (all parts), *Metallic flanges*

AS/NZS 4671, *Steel for the reinforcement of concrete*

AS/NZS 5263.1.2, *Gas appliances, Part 1.2: Gas fired water heaters for hot water supply and/or central heating*

NZS 3109, *Concrete construction*

NZS 3124, *Specification for concrete construction for minor works*

NZS 3631, *New Zealand timber grading rules*

NZS 3640, *Chemical preservation of round and sawn timber*

NZS 4305, *Energy efficiency—Domestic type hot water systems*

NZS 4608, *Control valves for hot water systems*

NZS 5807, *Code of practice for industrial identification by colour, wording or other coding*

NZS/BS 21, *Pipe threads for tubes and fittings where pressure-tight joints are made on the threads (metric dimensions)*

AS ISO 7.1, *Pipe threads where pressure-tight joints are made on the threads, Part 1: Dimensions, tolerances and designation*

ISO 15874-2, *Plastics piping systems for hot and cold water installations — Polypropylene (PP) — Part 2: Pipes*

ISO 15874-3, *Plastics piping systems for hot and cold water installations — Polypropylene (PP) — Part 3: Fittings*

BS 5422, *Method for specifying thermal insulating materials for pipes, tanks, vessels, ductwork and equipment operating within the temperature range  $-40\text{ }^{\circ}\text{C}$  to  $+700\text{ }^{\circ}\text{C}$*

ASTM A182/A182M, *Standard Specification for Forged or Rolled Alloy and Stainless Steel Pipe Flanges, Forged Fittings, and Valves and Parts for High-Temperature Service*

ASTM D2846, *Standard Specification for Chlorinated Poly(Vinyl Chloride) Plastic Hot- and Cold-Water Distribution Systems*

*Australian Solar Radiation Data Handbook*, 2006, 4th ed. NSW: Australian and New Zealand Solar Energy Society

*Guidance on use of rainwater tanks*, 2010, 3rd edition. Department of Health, Australian Government

National Construction Code (NCC) Volume 3, *Plumbing Code of Australia*

National Institute of Water and Atmospheric Research (NIWA), Wellington

New Zealand Building Code (NZBC), *Clause G1 Personal hygiene*

New Zealand Building Code (NZBC), *Clause G12 Water supplies*

New Zealand Building Code (NZBC), *Clause H1 Energy Efficiency*

## NOTES

### **Standards Australia**

Standards Australia is an independent company, limited by guarantee, which prepares and publishes most of the voluntary technical and commercial standards used in Australia. These standards are developed through an open process of consultation and consensus, in which all interested parties are invited to participate. Through a Memorandum of Understanding with the Commonwealth government, Standards Australia is recognized as Australia's peak national standards body.

### **Standards New Zealand**

The first national Standards organization was created in New Zealand in 1932. The New Zealand Standards Executive is established under the Standards and Accreditation Act 2015 and is the national body responsible for the production of Standards.

### **Australian/New Zealand Standards**

Under a Memorandum of Understanding between Standards Australia and Standards New Zealand, Australian/New Zealand Standards are prepared by committees of experts from industry, governments, consumers and other sectors. The requirements or recommendations contained in published Standards are a consensus of the views of representative interests and also take account of comments received from other sources. They reflect the latest scientific and industry experience. Australian/New Zealand Standards are kept under continuous review after publication and are updated regularly to take account of changing technology.

### **International Involvement**

Standards Australia and Standards New Zealand are responsible for ensuring that the Australian and New Zealand viewpoints are considered in the formulation of international Standards and that the latest international experience is incorporated in national and Joint Standards. This role is vital in assisting local industry to compete in international markets. Both organizations are the national members of ISO (the International Organization for Standardization) and IEC (the International Electrotechnical Commission).

### **Visit our websites**

[www.standards.org.au](http://www.standards.org.au) [www.standards.govt.nz](http://www.standards.govt.nz)



GPO Box 476 Sydney NSW 2001  
Phone (02) 9237 6000  
mail@standards.org.au  
www.standards.org.au



PO Box 1473 Wellington 6140  
Free phone 0800 782 632  
enquiries@standards.govt.nz  
www.standards.govt.nz