

AS 3600—2001
(Incorporating Amendment No. 1 and
Amendment No. 2 attached)

AS 3600—2001

Australian Standard™

Concrete structures



This Australian Standard was prepared by Committee BD-002, Concrete Structures. It was approved on behalf of the Council of Standards Australia on 11 April 2001. This Standard was published on 5 June 2001.

The following are represented on Committee BD-002:

AUSTROADS

Australian Building Codes Board
Australian Pre-Mixed Concrete Association
Bureau of Steel Manufacturers of Australia
Cement & Concrete Association of Australia
Concrete Institute of Australia
Curtin University of Technology
Institution of Engineers Australia
Master Builders Australia
National Precast Concrete Association Australia
Steel Reinforcement Institute of Australia
The Association of Consulting Engineers Australia
The University of Adelaide
The University of Melbourne
The University of New South Wales
The University of Western Sydney

Keeping Standards up-to-date

Standards are living documents which reflect progress in science, technology and systems. To maintain their currency, all Standards are periodically reviewed, and new editions are published. Between editions, amendments may be issued. Standards may also be withdrawn. It is important that readers assure themselves they are using a current Standard, which should include any amendments which may have been published since the Standard was purchased.

Detailed information about Standards can be found by visiting the Standards Web Shop at www.standards.com.au and looking up the relevant Standard in the on-line catalogue.

Alternatively, the printed Catalogue provides information current at 1 January each year, and the monthly magazine, *The Global Standard*, has a full listing of revisions and amendments published each month.

Australian Standards™ and other products and services developed by Standards Australia are published and distributed under contract by SAI Global, which operates the Standards Web Shop.

We also welcome suggestions for improvement in our Standards, and especially encourage readers to notify us immediately of any apparent inaccuracies or ambiguities. Contact us via email at mail@standards.org.au, or write to the Chief Executive, Standards Australia International Ltd, GPO Box 5420, Sydney, NSW 2001.

This Standard was issued in draft form for comment as DR 99193.

Australian Standard™

Concrete structures

Originated as part of AS A26—1934, AS CA2—1934 and MP 13—1957.

Previous edition AS 3600—1994.

Third edition 2001.

Reissued incorporating Amendment No. 1 (May 2002).

Reissued with Amendment No. 2 attached (October 2004)

COPYRIGHT

© Standards Australia International

All rights are reserved. No part of this work may be reproduced or copied in any form or by any means, electronic or mechanical, including photocopying, without the written permission of the publisher.

Published by Standards Australia International Ltd GPO Box 5420, Sydney, NSW 2001, Australia

ISBN 0 7337 3931 8

PREFACE

This Standard was prepared by Standards Australia Committee BD-002, Concrete Structures, to supersede AS 3600—1994.

This edition of the Standard includes Amendment No. 1 (May 2002) which is incorporated in the document. The changes required by the Amendment are indicated in the text by a marginal bar and amendment number against the clause, note, table, figure or part thereof affected. Amendment No. 2 (October 2004) is attached at the end of the document.

Objective of the Standard

The principal objective of the Standard is to provide users with nationally acceptable unified rules for the design and detailing of concrete structures and elements, with or without steel reinforcement or prestressing tendons, based on the principles of structural engineering mechanics. The secondary objective is to provide performance criteria against which the finished structure can be assessed for compliance with the relevant design requirements.

Background to the Third Edition

Amendment No. 1 to the 1994 edition of the Standard was issued in August 1996 to take account of the low ductility of wire to AS 1303 and mesh to AS 1304. It also incorporated improvements based on user experience in implementing AS 3600.

Following a five-year review, further amendments to the Standard were approved by the Concrete Structures Committee in August 1999. These amendments take account of more recent revisions of key materials Standards, and incorporate additional improvements to the clarity and intent of particular requirements, based on user comments.

In view of the number and extent of the amendments to AS 3600 now involved, the SAI Concrete Structures Committee recommended that, rather than issuing further 'green slip' amendments, a Third Edition of AS 3600 be published which incorporated all published and approved amendments, Amendment 1 and 2.

Differences between the Second and Third editions of AS 3600

As noted in the opening paragraphs of the Preface, this Edition incorporates Amendment No. 1 of August 1996 and amendments approved in August 1999.

Areas of major change covered in Amendment 2, which have been incorporated into this edition, are as follows:

- 1 Introduction of 500 MPa reinforcing steel with AS/NZS 4671 covering the specification for the new grade of reinforcing steel. The carbon equivalent of the reinforcement has been held to a level so that current practices for site welding of reinforcement including 'locational tack welding' can continue to be used.
- 2 Increase in the maximum concrete compressive strength to 65 MPa.
- 3 Consistency of references and information within AS 1379—*Specification and supply of concrete*, including a change to the basic shrinkage strain value to reflect normal class concrete.
- 4 Fire-resistance periods for the structural adequacy for columns has been revised following research by BRANZ, and allowances for chases and recesses in concrete walls have been included and are consistent with those in AS 3700, *Masonry structures*.
- 5 Linear elastic analysis requirements have been reviewed with consideration of propping, effective stiffness, secondary effects and moment redistribution.

- 6 Beam strength and serviceability design requirements have been significantly reviewed with changes to the minimum strength requirements, deflection by simplified calculation, the deemed to comply span-to-depth ratios, crack control provisions and end anchorage of fitments among others. The maximum transverse bar spacing have also been increased.
- 7 Changes have been made to the rules for flexural crack control of slabs, including reduction of the maximum transverse bar spacing.
- 8 Development length and splicing of reinforcement has been revisited and include amendments to the deemed to comply lengths and the size of bars permitted in tension and compression lapped splices. Rules for welded and mechanical splices have been removed and new rules are under development.
- 9 Material requirements have been updated with reference to the current AS 1379 and the new reinforcing steels to AS/NZS 4671.
- 10 Section 20 has been deleted in its entirety, with all aspects of the testing and assessment of concrete referred to AS 1379.
- 11 Section 21, on the testing of members and structures, has been completely redrafted and relabelled as Appendix B.

The Committee is in the process of a major revision of AS 3600, which includes the areas of high-strength concrete, bond and anchorage requirements and application of mechanical and welded splices.

The terms 'normative' and 'informative' have been used in this Standard to define the application of the appendix to which they apply. A 'normative' appendix is an integral part of a Standard, whereas an 'informative' appendix is only for information and guidance.

CONTENTS

	<i>Page</i>
SECTION 1 SCOPE AND GENERAL	
1.1 SCOPE AND APPLICATION.....	8
1.2 REFERENCED DOCUMENTS	9
1.3 USE OF ALTERNATIVE MATERIALS OR METHODS	9
1.4 DESIGN	9
1.5 CONSTRUCTION.....	10
1.6 DEFINITIONS	10
1.7 NOTATION	14
SECTION 2 DESIGN REQUIREMENTS AND PROCEDURES	
2.1 DESIGN REQUIREMENTS	22
2.2 DESIGN FOR STABILITY.....	22
2.3 DESIGN FOR STRENGTH.....	22
2.4 DESIGN FOR SERVICEABILITY	22
2.5 DESIGN FOR STRENGTH AND SERVICEABILITY BY LOAD TESTING OF A PROTOTYPE	24
2.6 DESIGN FOR DURABILITY	24
2.7 DESIGN FOR FIRE RESISTANCE.....	24
2.8 OTHER DESIGN REQUIREMENTS	24
SECTION 3 LOADS AND LOAD COMBINATIONS FOR STABILITY, STRENGTH AND SERVICEABILITY	
3.1 LOADS AND OTHER ACTIONS.....	25
3.2 LOAD COMBINATIONS FOR STABILITY DESIGN	25
3.3 LOAD COMBINATIONS FOR STRENGTH DESIGN	26
3.4 LOAD COMBINATIONS FOR SERVICEABILITY DESIGN.....	26
3.5 LOAD COMBINATIONS FOR FIRE-RESISTANCE DESIGN	26
SECTION 4 DESIGN FOR DURABILITY	
4.1 APPLICATION OF SECTION.....	27
4.2 DESIGN FOR DURABILITY	27
4.3 EXPOSURE CLASSIFICATION	27
4.4 REQUIREMENTS FOR CONCRETE FOR EXPOSURE CLASSIFICATIONS A1 AND A2.....	29
4.5 REQUIREMENTS FOR CONCRETE FOR EXPOSURE CLASSIFICATIONS B1, B2 AND C.....	30
4.6 REQUIREMENTS FOR CONCRETE FOR EXPOSURE CLASSIFICATION U	30
4.7 ADDITIONAL REQUIREMENTS FOR ABRASION	30
4.8 ADDITIONAL REQUIREMENTS FOR FREEZING AND THAWING	31
4.9 RESTRICTIONS ON CHEMICAL CONTENT IN CONCRETE.....	31
4.10 REQUIREMENTS FOR COVER TO REINFORCING STEEL AND TENDONS....	31
SECTION 5 DESIGN FOR FIRE RESISTANCE	
5.1 SCOPE OF SECTION	34
5.2 DEFINITIONS	34
5.3 DESIGN REQUIREMENTS	35
5.4 FIRE-RESISTANCE PERIODS FOR BEAMS	35
5.5 FIRE-RESISTANCE PERIODS FOR SLABS.....	37
5.6 FIRE-RESISTANCE PERIODS FOR COLUMNS.....	39

	<i>Page</i>
5.7 FIRE-RESISTANCE PERIODS FOR WALLS	40
5.8 FIRE-RESISTANCE PERIODS FROM FIRE TESTS	43
5.9 PREDICTION OF FIRE-RESISTANCE PERIODS	44
5.10 INCREASE OF FIRE-RESISTANCE PERIODS BY USE OF INSULATING MATERIALS	44
5.11 RECESSES FOR SERVICES IN WALLS.....	46
5.12 CHASES.....	46
 SECTION 6 DESIGN PROPERTIES OF MATERIALS	
6.1 PROPERTIES OF CONCRETE	48
6.2 PROPERTIES OF REINFORCEMENT	52
6.3 PROPERTIES OF TENDONS.....	53
6.4 LOSS OF PRESTRESS IN TENDONS.....	55
 SECTION 7 METHODS OF STRUCTURAL ANALYSIS	
7.1 GENERAL	59
7.2 SIMPLIFIED METHOD FOR REINFORCED CONTINUOUS BEAMS AND ONE-WAY SLABS.....	62
7.3 SIMPLIFIED METHOD FOR REINFORCED TWO-WAY SLABS SUPPORTED ON FOUR SIDES.....	63
7.4 SIMPLIFIED METHOD FOR REINFORCED TWO-WAY SLAB SYSTEMS HAVING MULTIPLE SPANS	64
7.5 IDEALIZED FRAME METHOD FOR STRUCTURES INCORPORATING TWO-WAY SLAB SYSTEMS.....	67
7.6 LINEAR ELASTIC ANALYSIS	69
7.7 ELASTIC ANALYSIS OF FRAMES INCORPORATING SECONDARY BENDING MOMENTS.....	72
7.8 RIGOROUS STRUCTURAL ANALYSIS	72
7.9 PLASTIC METHODS OF ANALYSIS FOR SLABS	73
7.10 PLASTIC METHODS OF ANALYSIS OF FRAMES.....	73
 SECTION 8 BEAMS FOR STRENGTH AND SERVICEABILITY	
8.1 STRENGTH OF BEAMS IN BENDING	74
8.2 STRENGTH OF BEAMS IN SHEAR	78
8.3 STRENGTH OF BEAMS IN TORSION	83
8.4 LONGITUDINAL SHEAR IN BEAMS	85
8.5 DEFLECTION OF BEAMS	87
8.6 CRACK CONTROL OF BEAMS.....	89
8.7 VIBRATION OF BEAMS.....	92
8.8 T-BEAMS AND L-BEAMS.....	92
8.9 SLENDERNESS LIMITS FOR BEAMS.....	92
 SECTION 9 DESIGN OF SLABS FOR STRENGTH AND SERVICEABILITY	
9.1 STRENGTH OF SLABS IN BENDING.....	94
9.2 STRENGTH OF SLABS IN SHEAR.....	97
9.3 DEFLECTION OF SLABS.....	100
9.4 CRACK CONTROL OF SLABS.....	103
9.5 VIBRATION OF SLABS	106
9.6 MOMENT RESISTING WIDTH FOR ONE-WAY SLABS SUPPORTING CONCENTRATED LOADS	106
9.7 LONGITUDINAL SHEAR IN COMPOSITE SLABS	107

SECTION 10 DESIGN OF COLUMNS FOR STRENGTH AND SERVICEABILITY	
10.1 GENERAL	108
10.2 DESIGN PROCEDURES	108
10.3 DESIGN OF SHORT COLUMNS.....	109
10.4 DESIGN OF SLENDER COLUMNS.....	110
10.5 SLENDERNESS.....	111
10.6 STRENGTH OF COLUMNS IN COMBINED BENDING AND COMPRESSION	115
10.7 REINFORCEMENT REQUIREMENTS FOR COLUMNS.....	116
10.8 TRANSMISSION OF AXIAL FORCE THROUGH FLOOR SYSTEMS	119
SECTION 11 DESIGN OF WALLS	
11.1 APPLICATION	120
11.2 DESIGN PROCEDURES	120
11.3 BRACING OF WALLS.....	120
11.4 SIMPLIFIED DESIGN METHOD FOR BRACED WALLS SUBJECT TO VERTICAL FORCES ONLY	121
11.5 DESIGN OF WALLS FOR IN-PLANE HORIZONTAL FORCES.....	122
11.6 REINFORCEMENT REQUIREMENTS FOR WALLS	123
SECTION 12 DESIGN OF NON-FLEXURAL MEMBERS, END ZONES AND BEARING SURFACES	
12.1 DESIGN OF NON-FLEXURAL MEMBERS.....	124
12.2 ANCHORAGE ZONES FOR PRESTRESSING ANCHORAGES.....	126
12.3 BEARING SURFACES.....	127
SECTION 13 STRESS DEVELOPMENT AND SPLICING OF REINFORCEMENT AND TENDONS	
13.1 STRESS DEVELOPMENT IN REINFORCEMENT	129
13.2 SPLICING OF REINFORCEMENT.....	130
13.3 STRESS DEVELOPMENT IN TENDONS.....	132
13.4 COUPLING OF TENDONS.....	132
SECTION 14 JOINTS, EMBEDDED ITEMS, FIXINGS AND CONNECTIONS	
14.1 DESIGN OF JOINTS	133
14.2 EMBEDDED ITEMS AND HOLES IN CONCRETE	133
14.3 REQUIREMENTS FOR FIXINGS.....	134
14.4 CONNECTIONS	134
SECTION 15 PLAIN CONCRETE MEMBERS	
15.1 APPLICATION	135
15.2 DESIGN	135
15.3 STRENGTH IN BENDING.....	135
15.4 STRENGTH IN SHEAR	135
15.5 STRENGTH IN AXIAL COMPRESSION.....	136
15.6 STRENGTH IN COMBINED BENDING AND COMPRESSION.....	136
SECTION 16 CONCRETE PAVEMENTS, FLOORS AND RESIDENTIAL FOOTINGS	
16.1 APPLICATION	137
16.2 ADDITIONAL DESIGN CONSIDERATIONS FOR PAVEMENTS AND INDUSTRIAL AND COMMERCIAL FLOORS.....	137
16.3 RESIDENTIAL FLOORS AND FOOTINGS.....	137

	<i>Page</i>
SECTION 17 LIQUID RETAINING STRUCTURES—DESIGN REQUIREMENTS	137
SECTION 18 MARINE STRUCTURES	
18.1 APPLICATION	138
18.2 ADDITIONAL LOADS AND ACTIONS	138
18.3 ADDITIONAL DURABILITY AND DESIGN REQUIREMENTS	138
SECTION 19 MATERIAL AND CONSTRUCTION REQUIREMENTS	
19.1 MATERIAL AND CONSTRUCTION REQUIREMENTS FOR CONCRETE AND GROUT	139
19.2 MATERIAL AND CONSTRUCTION REQUIREMENTS FOR REINFORCING STEEL	142
19.3 MATERIAL AND CONSTRUCTION REQUIREMENTS FOR PRESTRESSING DUCTS, ANCHORAGES AND TENDONS	144
19.4 CONSTRUCTION REQUIREMENTS FOR JOINTS AND EMBEDDED ITEMS	146
19.5 TOLERANCES FOR STRUCTURES AND MEMBERS	146
19.6 FORMWORK	147
APPENDICES	
A ADDITIONAL REQUIREMENTS FOR STRUCTURES SUBJECT TO EARTHQUAKE ACTIONS	151
B TESTING OF MEMBERS AND STRUCTURES	161
C REFERENCED DOCUMENTS	167
INDEX	170

STANDARDS AUSTRALIA

Australian Standard
Concrete structures

SECTION 1 SCOPE AND GENERAL

1.1 SCOPE AND APPLICATION**1.1.1 Scope**

This Standard sets out minimum requirements for the design and construction of concrete structures and members that contain reinforcing steel, or tendons, or both. It also sets out minimum requirements for plain concrete members.

This Standard will be referenced in the Building Code of Australia by way of BCA Amendment No. 9 to be published by 1 July 2001, thereby superseding the previous edition, AS 3600—1994, which will be withdrawn 12 months from the date of publication of this edition.

1.1.2 Application

This Standard is intended to apply to concrete structures made of concrete—

- (a) with a characteristic compressive strength at 28 days (f'_c) in the range of 20 MPa to 65 MPa; and
- (b) with a saturated surface-dry density in the range 1800 kg/m³ to 2800 kg/m³.

The Standard also applies to reinforcing steels complying with—

- (a) AS 1302, or having a yield strength (f_{sy}) of 500 MPa and Ductility Class N in accordance with AS/NZS 4671. These reinforcing materials may be used, without restriction, in all applications referred to in this Standard; and
- (b) AS 1303 or AS 1304, or having a yield strength (f_{sy}) of 500 MPa and Ductility Class L in accordance with AS/NZS 4671. These reinforcing materials shall not be used in any situation where the reinforcement, is expected to undergo large deformation under strength limit state conditions.

NOTE: The use of Ductility Class L reinforcement is further limited by other clauses within this Standard.

- (c) Prestressing tendons complying with AS 1310, AS 1311, or AS 1313, as appropriate.

For concrete road bridges and for concrete railway bridges, HB77.5 and HB77.8, respectively, shall be used where applicable.

The general principles of concrete design and construction embodied in this Standard may be applied to concrete other than that specified above, or to concrete structures or members not specifically mentioned herein.

This Standard is not intended to apply to the design of mass concrete structures. It is also not intended that the requirements of this Standard should take precedence over those of other Australian Standards.

NOTES:

- 1 It is intended that the design of a structure or member, to which this Standard applies, be carried out by, or under the supervision of, a suitably experienced and competent person.

- 2 Consideration is being given to extending the application of the Standard to structures in which the characteristic compressive strength of concrete (f'_c) is greater than 65 MPa. However, before such an extension could be incorporated, current research data indicates that some requirements of the Standard would need to be more stringent than those presently given and others appropriately modified.

1.2 REFERENCED DOCUMENTS

The documents referred to in this Standard are listed in Appendix C.

1.3 USE OF ALTERNATIVE MATERIALS OR METHODS

1.3.1 General

Provided that the requirements of Section 2 are met, this Standard shall not be interpreted so as to prevent the use of materials or methods of design or construction not specifically referred to herein.

NOTE: Where the intended use is subject to the control of a Building Authority, approval for the use of alternative materials or methods will need to be obtained from the Authority.

1.3.2 Existing structures

Where the strength or serviceability of an existing structure is to be evaluated, the general principles of this Standard may be applied. (See also Appendix B.)

1.4 DESIGN

1.4.1 Design data

The following design data shall be shown in the drawings:

- (a) Reference number and date of issue of applicable design Standards.
- (b) Live loads used in design.
- (c) Exposure classification for durability.
- (d) Fire-resistance rating, if applicable.
- (e) Class and, where appropriate, grade designation of concrete.
- (f) Grade, Ductility Class and type of reinforcement and grade and type of tendons.
- (g) The appropriate earthquake design category, acceleration coefficient and site factor determined from AS 1170.4.

1.4.2 Design details

The drawings or specification for concrete members and structures shall include, as appropriate, the following:

- (a) The shape and size of each member.
- (b) The finish and method of control for unformed surfaces.
- (c) Class of formwork in accordance with AS 3610 for the surface finish specified.
- (d) The size, quantity and location of all reinforcement, tendons and structural fixings and the cover to each.
- (e) Any required properties of the concrete.
- (f) The curing procedure.
- (g) The force required in each tendon, the maximum jacking force to be applied and the order in which tendons are to be stressed.

- (h) The location and details of planned construction or movement joints, connections and splices, and the method to be used for their protection.
- (i) The minimum period of time before stripping of forms and removal of shores.
- (j) Any constraint on construction assumed in the design.
- (k) Any other requirements.

1.5 CONSTRUCTION

All concrete structures, designed in accordance with this Standard, shall be constructed to ensure that all the requirements of the design as contained in the drawings and specifications are achieved.

1.6 DEFINITIONS

1.6.1 General

The definitions below apply to this Standard. Definitions peculiar to a particular Clause or Section are given in that clause or section and referred to below.

1.6.2 Administrative definitions

1.6.2.1 *Approved*

Except as may be otherwise stated, approved by the relevant Authority.

1.6.2.2 *Building authority or other relevant regulatory authority*

A body having statutory powers to control the design and erection of the structure in the area in which the structure is to be erected.

1.6.2.3 *Drawings*

The drawings forming part of the documents setting out the work to be executed.

1.6.2.4 *Specification*

The specification forming part of the documents setting out the work to be executed.

1.6.3 Technical definitions

1.6.3.1 *Action*

Any agent, such as imposed load, foundation movement or temperature gradient, which may act on a structure.

1.6.3.2 *Action effects*

The forces and moments, deformations, cracks and other effects, which are produced in a structure or in its component members by an action.

1.6.3.3 *Average ambient temperature*

The mean value of the daily maximum and minimum ambient temperatures at a site, averaged over the relevant period (i.e. $(\Sigma T_{\max.} + \Sigma T_{\min.}) / (2 \times \text{number of days})$).

1.6.3.4 *Cement*

Portland or blended cement complying with AS 3972, or a mixture of either of these with one or more supplementary cementitious materials complying with AS 3582.

1.6.3.5 *Characteristic strength*

That value of the material strength, as assessed by standard test, which is exceeded by 95% of the material.

1.6.3.6 *Composite concrete member*

A member consisting of concrete components constructed separately but structurally connected so that the member responds as a unit to applied actions.

1.6.3.7 *Concrete*

A mixture of cement, aggregates, and water, with or without the addition of chemical admixtures.

1.6.3.8 *Construction joint*

A joint, including a joint between precast segments, that is located in a part of a structure for convenience of construction and made so that the load-carrying capacity and serviceability of the structure will be unimpaired by the inclusion of the joint.

1.6.3.9 *Cover*

The distance between the outside of the reinforcing steel or tendons and the nearest permanent surface of the member excluding any surface finish.

NOTE: Unless otherwise noted, the tolerances on position of reinforcement and tendons given in Clause 19.5.3 apply.

1.6.3.10 *Creep factor*

The ratio of creep strain to elastic strain under conditions of constant stress.

1.6.3.11 *Critical tensile zone*

A region of a beam or slab where the design bending moment at the serviceability limit state ($M_{s,1}^*$), calculated with short-term load factor $\psi_s = 1.0$, equals or exceeds the critical moment for flexural cracking (M_{crit}), which is calculated assuming a flexural tensile strength of concrete equal to 3.0 MPa.

1.6.3.12 *Direct loading*

Loading on a structure that includes the self-weight of its component elements and externally applied loads.

1.6.3.13 *Ductility Class*

A designation relating to the ductility of reinforcement, ('L' designates 'low', 'N' designates 'normal').

1.6.3.14 *Effective depth*

The distance from the extreme compressive fibre of the concrete to the resultant tensile force in the reinforcing steel and tendons in that zone which will be tensile at the ultimate strength condition in pure bending.

1.6.3.15 *Effective span*

The lesser of $(L_n + D)$ and L .

1.6.3.16 *Exposure classification*

See Clause 4.3.

1.6.3.17 *Fire-resistance level*

See Clause 5.2.

1.6.3.18 *Fire-resistance period*

See Clause 5.2

1.6.3.19 *Fire-separating function*

See Clause 5.2.

1.6.3.20 *Fitment*

A unit of reinforcement commonly known as a tie, stirrup, ligature or helix.

1.6.3.21 *Flat slab*

A continuous two-way solid or ribbed slab, with or without drop-panels, having at least two spans in each direction, supported internally by columns without beams and supported externally by walls, or columns with or without spandrel beams, or both.

1.6.3.22 *Footing*

A part of a structure in direct contact with and transmitting load to the supporting foundation.

1.6.3.23 *Foundation*

The soil, subsoil or rock, whether built-up or natural, upon which a structure is supported.

1.6.3.24 *Grout*

A mixture of cement and water, with or without the addition of sand, or chemical admixtures, proportioned to produce a pourable liquid without segregation of the constituents.

1.6.3.25 *Headed reinforcement*

A steel bar that achieves anchorage by means of a suitably sized head or end plate (see Clause 13.1.2.6).

1.6.3.26 *Hollow-core slab or wall*

See Clause 5.2.

1.6.3.27 *Initial force*

The force immediately after transfer, at a stated position in a tendon.

1.6.3.28 *Insulation*

See Clause 5.2.

1.6.3.29 *Integrity*

See Clause 5.2.

1.6.3.30 *Jacking force*

The force in a tendon measured at the jack.

1.6.3.31 *Lightweight concrete*

Concrete made with lightweight coarse and normal-weight fine aggregates and having a saturated surface-dry density in the range of 1800 kg/m³ to 2100 kg/m³.

1.6.3.32 *Limit state*

Any limiting condition for which the structure ceases to fulfil its intended function.

1.6.3.33 *Loadbearing member*

See Clause 5.2.

1.6.3.34 *Movement joint*

A joint that is made in or between portions of a structure for the specific purpose of permitting relative movement between the parts of the structure on either side of the joint.

1.6.3.35 *Normal-class concrete*

Concrete is specified primarily by a Standard strength grade and which complies with AS 1379.

1.6.3.36 *One-way slab*

A slab characterized by flexural action mainly in one direction.

1.6.3.37 *Plain concrete member*

A member either unreinforced or containing reinforcement but assumed to be unreinforced.

1.6.3.38 *Post-tensioning*

The tensioning of tendons after the concrete has hardened.

1.6.3.39 *Prestressed concrete*

Concrete into which internal stresses are induced deliberately by tendons and include concrete commonly referred to as partially prestressed.

1.6.3.40 *Prestressing steel*

See tendon.

1.6.3.41 *Pretensioning*

The tensioning of tendons before the concrete is placed.

1.6.3.42 *Reinforcement, reinforcing steel*

Steel bar, wire, or mesh but not tendons.

1.6.3.43 *Ribbed slab*

See Clause 5.2.

1.6.3.44 *Shear wall*

A wall that is intended to resist lateral forces acting in or parallel to the plane of the wall.

1.6.3.45 *Slag*

Ground granulated iron blast furnace slag complying with AS 3582.2.

1.6.3.46 *Special-class concrete*

Concrete specified to have certain properties or characteristics different from or additional to those of normal-class concrete, and which complies with AS 1379.

1.6.3.47 *Strength grade*

The numerical value of the characteristic compressive strength of concrete at 28 days (f'_c). (see Clauses 6.1.1.1 and 19.1.6)

1.6.3.48 *Structural adequacy*

See Clause 5.2.

1.6.3.49 *Tendon*

A wire, strand or bar or any discrete group of such wires, strands or bars, which is intended to be pretensioned or post-tensioned.

1.6.3.50 *Transfer*

The time of initial transfer of prestressing forces from the tendons to the concrete.

1.6.3.51 *Transmission length*

The length, at transfer, over which the stress in a pretensioned tendon builds up from zero at one end to its full value.

1.6.3.52 *Two-way slab*

A slab characterized by significant flexural action in two directions, usually at right angles to one another.

1.6.3.53 *Uniform elongation*

Uniform strain of reinforcement at maximum stress, corresponding to the onset of necking.

1.7 NOTATION

Every symbol used in this Standard is listed below. Symbols that occur in more than one clause are defined below and used in the various clauses without further reference. Symbols that occur only in one clause are defined in that clause as well as being listed below.

Unless a contrary intention appears, the following applies:

- (a) The symbols used in this Standard shall have the meanings ascribed to them below, with respect to the structure, or member, or condition to which a clause is applied.
- (b) Where non-dimensional ratios are involved, both the numerator and denominator are expressed in identical units.
- (c) The dimensional units for length, force and stress in all expressions or equations are to be taken as millimetres (mm), newtons (N) and megapascals (MPa) respectively.
- AI | (d) An asterisk (*) placed after a symbol as a superscript (e.g. M^*) denotes a design action effect due to the design load.

Symbol	Definition
A_b	= the cross-sectional area of a reinforcing bar
A_c	= the cross-sectional area of the core of a column used in Appendix A
A_{ct}	= the cross-sectional area of concrete in the tensile zone assuming the section is uncracked
A_g	= the gross cross-sectional area of a member
A_m	= an area (see Clause 8.3.3)
A_p	= the cross-sectional area of prestressing steel
A_{pt}	= the cross-sectional area of the tendons in that zone, which will be tensile under ultimate load conditions
A_s	= the cross-sectional area of reinforcement
A_{sc}	= the cross-sectional area of compression reinforcement
A_{st}	= the cross-sectional area of tension reinforcement
	= the cross-sectional area of reinforcement in the zone which would be in tension under the design loads other than prestressing or axial loads
$A_{st.min.}$	= the minimum cross-sectional area of reinforcement permitted in a beam in tension, or in a critical tensile zone of a beam or slab in flexure
A_{sv}	= the cross-sectional area of shear reinforcement
$A_{sv.min.}$	= the cross-sectional area of minimum shear reinforcement
A_{sw}	= the cross-sectional area of the bar forming a closed tie

A_t	=	the area of a polygon (see Clause 8.3.5)
A_{tr}	=	the cross-sectional to area of transverse reinforcement perpendicular to the layer of bars within a spacing, s (see Clause 13.2.5)
A_1	=	a bearing area (see Clause 12.3)
A_2	=	a supplementary area (see Clause 12.3)
A_1/A_2	=	a ratio of areas (see Clause 8.4.2)
a	=	a distance
a_s	=	the length of a span support (see Clause 7.1.2)
a_v	=	the distance from the section at which shear is being considered to the face of the nearest support (see Clause 8.2.7.1)
b	=	the width of a cross-section
b_c	=	the width of the compression strut (see Clause 12.1.2.2)
b_{ef}	=	the effective width of a compression face or flange of a member
b_f	=	the width of the shear interface (see Clause 8.4.3)
b_l	=	a member size (see Paragraph A12.3.3.2, Appendix A)
b_o	=	the width of a critical opening (see Clause 9.2.1)
b_t	=	a member size (see Paragraph A12.3.3.2, Appendix A)
b_v	=	the effective width of a web for shear (see Clause 8.2.6)
b_w	=	a width of the web; or
	=	the minimum thickness of the wall of a hollow section (see Clause 8.3.3)
c	=	the cover to reinforcing steel or tendons
D	=	the overall depth of a cross-section in the plane of bending
D_b	=	the overall depth of a spandrel beam
D_c	=	the smaller column dimension (see Clause 5.6.3.2 and 10.7.3.3)
D_g	=	the greater column dimension (see Clause 5.6.3.2)
D_s	=	the overall depth of a slab or drop panel
d	=	the effective depth of a cross-section (see Clause 1.6.3)
d_b	=	the nominal diameter of a bar, wire, or tendon
d_c	=	the depth of a compression strut (see Clause 12.1.2.2)
d_d	=	the diameter of a prestressing duct (see Clause 8.2.6)
d_o	=	the distance from the extreme compression fibre of the concrete to the centroid of the outermost layer of tensile reinforcement or tendons but for prestressed concrete members not less than $0.8D$
d_p	=	the distance from the extreme compressive fibre of the concrete to the centroid of the tendons in that zone which will be tensile under ultimate strength conditions
d_{sc}	=	the distance from the extreme compressive fibre of the concrete to the centroid of compressive reinforcement (see Clause 8.1.5)
E_c	=	the mean value of the modulus of elasticity of concrete at 28 days

E_{cj}	=	the mean value of the modulus of elasticity of concrete at the appropriate age, determined in accordance with Clause 6.1.2
E_p	=	the modulus of elasticity of tendons, determined in accordance with Clause 6.3.2
E_s	=	the modulus of elasticity of reinforcement, determined in accordance with Clause 6.2.2
e	=	the eccentricity of axial force from a centroidal axis; or = the base of Napierian logarithms
e_a	=	an additional eccentricity (see Clause 11.4.4)
F_c^*	=	the design force in the compression zone due to flexure (see Clause 8.3.6)
F_d	=	a uniformly distributed design load, factored for strength or serviceability as appropriate
$F_{d.ef}$	=	the effective design service load per unit length or area, used in serviceability design
$f_{c.28}$	=	the mean value of the compressive strength of concrete at 28 days
$f_{c.cal}$	=	the calculated compressive strength of concrete in a compression strut (see Clause 12.1.2.2)
f_{cm}	=	the mean value of the compressive strength of concrete at the relevant age
f_{cp}	=	the compressive strength of concrete at transfer
A1 f_{cs}	=	the maximum shrinkage-induced tensile stress on the uncracked section at the extreme fibre at which cracking occurs (see Clause 8.5.3.1)
f_{cv}	=	a concrete shear strength (see Clause 9.2.3)
f_p	=	the tensile strength of tendons determined in accordance with Clause 6.3.1
f_{py}	=	the yield strength of tendons determined in accordance with Clause 6.3.1
f_s	=	the maximum tensile stress permitted in the reinforcement immediately after the formation of a crack
f_{ser}	=	the tensile stress in reinforcement at a cracked section, due to the short-term load combination for the serviceability limit states when direct loads are applied
$f_{ser.1}$	=	the tensile stress in reinforcement at a cracked section, due to the short-term load combination for the serviceability limit states, calculated with $\psi_s = 1.0$, when direct loads are applied
f_{sy}	=	the yield strength of reinforcing steel, determined in accordance with Clause 6.2.1
$f_{sy.f}$	=	the yield strength of reinforcement used as fitments, determined in accordance with Clause 6.2.1
f'_c	=	the characteristic compressive cylinder strength of concrete at 28 days
f'_{cf}	=	the characteristic flexural tensile strength of concrete determined in accordance with Clause 6.1.1.2
f'_{ct}	=	the characteristic principal tensile strength of concrete determined in accordance with Clause 6.1.1.3
G	=	the dead load

	g	=	the dead load per unit length or area
	H_w	=	the overall height of a wall
	H_{wu}	=	the unsupported height of a wall
	H_{we}	=	the effective height of a wall
	I	=	a second moment of area, of the gross concrete cross-section about the centroidal axis
	I_c, I_f	=	the second moment of area of a column and a flexural member respectively
	I_{cr}	=	the second moment of area of a cracked section with the reinforcement transformed to an equivalent area of concrete
	I_{ef}	=	an effective second moment of area (see Clause 8.5.3)
	J_t	=	a torsional modulus
	j	=	a duration in days (see Clause 6.3.4.3)
	k	=	a coefficient, ratio, or factor used with and without numerical subscripts
	k_{cs}	=	a factor used in serviceability design to take account of the long-term effects of creep and shrinkage
	k_m	=	a coefficient calculated in accordance with Clause 10.4.2
	k_r	=	a ratio (see Clause 12.2.4)
	k_s	=	a coefficient that takes into account the shape of the stress distribution within the section immediately prior to cracking, as well as the effect of non-uniform self-equilibrating stresses
A1	k_u	=	the neutral axis parameter, being the ratio, at ultimate strength and under any combination of bending and compression, of the depth to the neutral axis from the extreme compressive fibre, to d
A1	k_{uo}	=	the ratio, at ultimate strength, of the depth to the neutral axis from the extreme compressive fibre, to d_o
	L	=	centre-to-centre distance between the supports of a flexural member
	L_e	=	the effective length of a column
	L_{ef}	=	the effective span of a member, taken as the lesser of $(L_n + D)$ and L for a beam or slab; or
		=	$L_n + D/2$ for a cantilever
	L_l	=	the distance between centres of lateral restraints
	L_n	=	the length of clear span in the direction in which moments are being determined, measured face-to-face of supporting beams, columns or walls, or for a cantilever, the clear projection
	L_o	=	a length of span (see Clause 7.4.2)
	L'_o	=	a length of span (see Clause 7.4.5)
	L_p	=	the development length for pretensioned tendons
	L_{pa}	=	a length of tendon (see Clause 6.4.2.3)
	L_s	=	the span between formwork supports (see Clause 19.6.2.4)
	L_{st}	=	the development length of a bar for a tensile stress less than the yield stress

- $L_{sy,c}(L_{sy,t})$ = the development length for compression (tension), being the length of embedment required to develop the yield strength of a bar in compression (tension)
- L_t = the width of a design strip (see Clause 7.1.2)
- L_u = the unsupported length of a column, taken as the clear distance between the faces of members capable of providing lateral support to the column. Where column capitals or haunches are present, L_u is measured to the lowest extremity of the capital or haunch
- L_w = the overall length of a wall
- L_x = the shorter effective span of a slab supported on four sides
- L_y = the longer effective span of a slab supported on four sides
- M^* = the bending moment at a cross-section calculated using the design load for strength specified in Clause 3.3, i.e. the design bending moment
- M_v^* = the design bending moment to be transferred from a slab to a support
- M_x^*, M_y^* = the design bending moment in a column about the major and minor axes respectively; or
- = the positive design bending moment, at midspan in a slab, in the x and y direction respectively
- M_1^*, M_2^* = the smaller and larger design bending moment respectively at the ends of a column
- M_{cr} = the bending moment causing cracking of the section with due consideration to prestress, restrained shrinkage and temperature stresses
- M_{crit} = the critical moment for flexural cracking calculated assuming a flexural tensile strength of concrete equal to 3.0 MPa
- M_o = the total static moment in a span (see Clause 7.4.2); or
- = the decompression moment (see Clause 8.2.7.2)
- M_s^* = the design bending moment at the serviceability limit state
- $M_{s,1}^*$ = the design bending moment at the serviceability limit state, calculated with $\psi_s = 1.0$
- M_u = the ultimate strength in bending at a cross-section of an eccentrically loaded compression member
- M_{ub} = the particular ultimate strength in bending when $k_{uo} = 0.003/(0.003 + f_{sy}/E_s)$
- M_{ud} = the reduced ultimate strength in bending without axial force, at a cross-section (see Clause 8.1.3(c))
- M_{uo} = the ultimate strength in bending without axial force, at a cross-section
- $(M_{uo})_{min.}$ = the minimum strength in bending at a critical cross-section (see Clause 8.1.4.1)
- M_{ux}, M_{uy} = the ultimate strength in bending about the major and minor axes respectively of a column under the design axial force N^*
- N^* = the axial compressive or tensile force on a cross-section calculated using the design load for strength specified in Clause 3.3, i.e. the design axial force
- N_c = the buckling load used in column design

N_u	= the ultimate strength in compression, or tension, at a cross-section of an eccentrically loaded compression or tension member respectively
N_{ub}	= the particular ultimate strength in compression of a cross-section when $k_{uo} = 0.003/(0.003 + f_{sy}/E_s)$
N_{uo}	= the ultimate strength in compression without bending, of an axially loaded cross-section
N_{uot}	= the ultimate strength in tension without bending, of an axially loaded cross-section
n	= the number of bars uniformly spaced around a helix (see Clause 13.2.5)
P	= the force in the tendons; or = the maximum force in the anchorage (see Clause 12.2.4)
P_v	= the vertical component of the prestressing force
p	= a reinforcement ratio
p_w	= a reinforcement ratio in a wall
Q	= the live load (including impact, if any)
q	= the live load per unit length or area
R	= the design relaxation of a tendon, determined in accordance with Clause 6.3.4.3
R_b	= the basic relaxation of a tendon, determined in accordance with Clause 6.3.4.2
R_u	= the ultimate strength (see Clause 2.3)
r	= the radius of gyration of a cross-section
S^*	= the design action effect (see Clause 2.3)
s	= the centre-to-centre spacing of shear or torsional reinforcement, measured parallel to the longitudinal axis of a member; or = the standard deviation; or = the maximum spacing of transverse reinforcement within $L_{sy,c}$, or spacing of stirrups or ties, or spacing of successive turns of a helix, all measured centre to centre, mm (see Clause 13.2.5)
T	= a temperature; or = the force resultant of tensile stresses (see Clause 12.2.4)
T^*	= the torsional moment at a cross-section calculated using the design load for strength specified in Clause 3.3, i.e. the design torsional moment
T_u	= the ultimate torsional strength
T_{uc}	= the ultimate torsional strength of a beam without torsional reinforcement and in the presence of shear
T_{us}	= the ultimate torsional strength of a beam with torsional reinforcement, (see Clause 8.3.5)
$T_{u,max.}$	= the ultimate torsional strength of a beam limited by web crushing failure
t_{nom}	= the nominal thickness of topping (see Clause 5.10.2)
t_d	= a difference in thicknesses (see Clause 5.10.2)

t_h	= the hypothetical thickness of a member used in determining creep and shrinkage, taken as $2A_g/u_e$
t_w	= the thickness of a wall
u	= the length of the critical shear perimeter for two-way action (see Clause 9.2.1)
u_e	= the exposed perimeter of a member cross-section plus half the perimeter of any closed voids contained therein, used to calculate t_h
u_t	= the perimeter of the polygon defined for A_t (see Clause 8.3.6)
V^*	= the shear force at a section, calculated using the design load for strength specified in Clause 3.3, i.e. the design shear force
V_o	= the shear force which would occur at a section when the bending moment at that section was equal to the decompression moment M_o
V_t	= the shear force producing a principal tensile stress (see Clause 8.2.7.2)
V_u	= the ultimate shear strength
$V_{u,max.}$	= the ultimate shear strength limited by web crushing failure
$V_{u,min.}$	= the ultimate shear strength of a beam provided with minimum shear reinforcement (see Clause 8.2.9)
V_{uc}	= the ultimate shear strength excluding shear reinforcement (see Clause 8.2.7)
V_{uf}	= the ultimate longitudinal shear strength at an interface
V_{uo}	= the ultimate shear strength of a slab with no moment transfer
V_{us}	= the contribution by shear reinforcement to the ultimate shear strength of a beam or wall (see Clauses 8.2.10, 11.5.5)
X	= a dimension (see Figure 9.2.1)
x	= the shorter overall dimension of a rectangular part of a cross-section; or = the smaller dimension of a component rectangle of a T-, L-, or I-section
Y	= a dimension (see Figure 9.2.1)
y	= the longer overall dimension of a rectangular part of a cross-section; or = the larger dimension of a component rectangle of a T-, L-, or I-section
y_1	= the larger dimension of a closed rectangular tie
Z	= the section modulus of an uncracked cross-section (see Clause 8.1.4.1)
α	= a coefficient
α_n	= a coefficient (see Clause 10.6.5)
α_{tot}	= an angular value in radians (see Clause 6.4.2.3)
α_v	= the angle between the inclined shear reinforcement and the longitudinal tensile reinforcement
β	= a coefficient with or without numerical subscripts; or = a fixity factor
β_d	= a factor (see Clause 10.4.3)
β_h	= a ratio (see Clause 9.2.1)

β_p	=	an estimated angular deviation in radians per metre (see Clause 6.4.2.3)
β_x, β_y	=	the short and long span bending moment coefficients respectively, for slabs supported on four sides
γ	=	the ratio, under design bending or combined bending and compression, of the depth of the assumed rectangular compressive stress block to $k_u d$
γ_1, γ_2	=	the column end restraint coefficients determined in accordance with Clause 10.5.3
Δ	=	a deflection
$\delta, \delta_b, \delta_s$	=	moment magnifiers for slenderness effects, (see Clause 10.4)
ε	=	a strain
ε_{cc}	=	the strain due to concrete creep (see Clause 6.4.3.3)
ε_{cs}	=	the design shrinkage strain determined in accordance with Clause 6.1.7.2
$\varepsilon_{cs.b}$	=	the basic shrinkage strain determined in accordance with Clause 6.1.7.1
ε_{su}	=	the uniform strain at maximum stress, corresponding to the onset of necking
θ_v, θ_t	=	the angle between the concrete compression strut and the longitudinal axis of the member (see Clauses 8.2.10, 8.3.5)
λ_{uc}	=	a ratio of loads (see Clause 10.4.3)
μ	=	the friction curvature coefficient (see Clause 6.4.2.3)
ν	=	Poisson's ratio for concrete, determined in accordance with Clause 6.1.5
ρ	=	the density of concrete, in kilograms per cubic metre (kg/m^3), determined in accordance with Clause 6.1.3
σ_{ci}	=	a sustained concrete stress (see Clause 6.4.3.3)
σ_{cp}	=	the average intensity of effective prestress in concrete
$\sigma_{cp.f}$	=	a compressive stress at the extreme fibre (see Clause 8.2.7.2)
σ_{pa}	=	the stress at a point in the tendon (see Clause 6.4.2.3)
$\sigma_{p.ef}$	=	the effective stress in the tendon (see Clause 8.1.6)
σ_{pi}	=	the stress in the tendon immediately after transfer
σ_{pj}	=	the stress in the tendon at the jacking end (see Clause 6.4.2.2)
σ_{pu}	=	the maximum stress which would be reached in a tendon at ultimate strength of a flexural member
σ_{st}	=	a calculated tensile stress in reinforcement (see Clause 13.1.2.2)
ϕ	=	the strength reduction factor (see Clause 2.3)
ϕ_{cc}	=	the design creep factor determined in accordance with Clause 6.1.8.2
$\phi_{cc.b}$	=	the basic creep factor determined in accordance with Clause 6.1.8.1
ψ_c	=	the combination live load factor used in assessing the design load for strength
ψ_s	=	the short-term live load factor used in assessing the design load for serviceability
ψ_l	=	the long-term live load factor used in assessing the design load for serviceability

SECTION 2 DESIGN REQUIREMENTS AND PROCEDURES

2.1 DESIGN REQUIREMENTS

2.1.1 Aim

The aim of structural design is to provide a structure that is durable, serviceable and has adequate strength while serving its intended function and that satisfies other relevant requirements such as robustness, ease of construction and economy.

A structure is durable if it withstands expected wear and deterioration throughout its intended life without the need for undue maintenance.

A structure is serviceable and has adequate strength if the probability of loss of serviceability and the probability of structural failure are both acceptably low throughout its intended life.

2.1.2 Requirements

The design of a structure and its component members shall take into account, as appropriate, stability, strength, serviceability, durability, fire resistance and any other relevant design requirements, in accordance with the procedures given in this Section.

2.2 DESIGN FOR STABILITY

The structure, as a whole, and its parts shall be designed to prevent instability due to overturning, uplift and sliding, as follows:

- (a) The design action effect and the design resistance effect shall be determined from Clause 3.2.
- (b) The whole or part of the structure shall be proportioned so that its design resistance effect is not less than the design action effect.

2.3 DESIGN FOR STRENGTH

The structure and its component members shall be designed for strength, as follows:

- (a) The loads and other actions shall be determined from Clause 3.1 and the design load for strength shall be determined from Clause 3.3.
- (b) The design action effect (S^*), due to the design load for strength, shall be determined by an appropriate analysis in accordance with the requirements of Section 7.
- (c) The design strength (ϕR_u), shall be determined in accordance with the requirements of Sections 8 to 15, as appropriate, where ϕ is a strength reduction factor, which shall not exceed the appropriate value given in Table 2.3.
- (d) The member shall be proportioned so that its design strength is not less than the design action effect, i.e. $\phi R_u \geq S^*$.

2.4 DESIGN FOR SERVICEABILITY

2.4.1 General

The structure and its component members shall be designed for serviceability by controlling or limiting deflection, lateral drift, cracking and vibration, as appropriate, in accordance with the relevant requirements of Clauses 2.4.2 to 2.4.5.

2.4.2 Deflection limits for beams and slabs

The deflection of beams and slabs under service conditions shall be controlled as follows:

- (a) A limit for the calculated deflection of the member shall be chosen appropriate to the structure and its intended use. The values chosen shall not exceed the relevant value given in Table 2.4.2.
- (b) The member shall be designed so that, under the design load for serviceability given in Clause 3.4, the deflections calculated in accordance with Section 8 or 9, as appropriate, do not exceed the chosen value.

TABLE 2.3
STRENGTH REDUCTION FACTORS

Type of action effect	Strength reduction factor (ϕ)
(a) Axial force without bending—	
(i) Tension	0.8
(ii) Compression	0.6
(b) Bending without axial tension or compression where:	
(i) $k_u \leq 0.4$	0.8
(ii) $k_u > 0.4$	$0.8 M_{ud}/M_{uo} \geq 0.6$
(c) Bending with axial tension	$\phi + [(0.8 - \phi)(N_u/N_{uot})]$ and ϕ is obtained from (b)
(d) Bending with axial compression where:	
(i) $N_u \geq N_{ub}$	0.6
(ii) $N_u < N_{ub}$	$0.6 + [(\phi - 0.6)(1 - N_u/N_{ub})]$ and ϕ is obtained from (b)
(e) Shear	0.7
(f) Torsion	0.7
(g) Bearing	0.6
(h) Compression and tension in strut and tie action	0.7
(i) Bending, shear and compression in plain concrete	0.6
(j) Bending, shear and tension in fixings	0.6

2.4.3 Lateral drift

Unbraced frames and multistorey buildings subject to lateral loading shall be designed to limit calculated inter-storey lateral drift to 1/500 of the storey height.

2.4.4 Cracking

The cracking of beams or slabs under service conditions shall be controlled in accordance with the requirements of Clause 8.6 or 9.4 as appropriate.

2.4.5 Vibration

The vibration of beams or slabs under service conditions shall be controlled in accordance with the requirements of Clause 8.7 or 9.5 as appropriate.

TABLE 2.4.2
LIMITS FOR CALCULATED DEFLECTION OF BEAMS AND SLABS

Type of member	Deflection to be considered	Deflection limitation (Δ/L_{ef}) for spans (Notes 1 and 2)	Deflection limitation (Δ/L_{ef}) for cantilevers (Note 3)
All members	The total deflection	1/250	1/125
Members supporting masonry partitions	The deflection which occurs after the addition or attachment of the partitions	1/500 where provision is made to minimize the effect of movement, otherwise 1/1000	1/250 where provision is made to minimize the effect of movement, otherwise 1/500
Bridge members	The live load (and impact) deflection	1/800	1/400

NOTES:

- 1 In flat slabs, the deflection to which the above limits apply is the theoretical deflection of the line diagram representing the idealized frame defined in Clause 7.5.2.
- 2 Deflection limits given may not safeguard against ponding.
- 3 For cantilevers, the values of Δ/L_{ef} given in this Table apply only if the rotation at the support is included in the calculation of Δ .

2.5 DESIGN FOR STRENGTH AND SERVICEABILITY BY LOAD TESTING OF A PROTOTYPE

Notwithstanding the requirements of Clauses 2.3 and 2.4, a structure or a component member may be designed for strength or serviceability, or both, by load testing a prototype in accordance with Appendix B using appropriate design loads determined from Clauses 3.3 or 3.4. If this alternative procedure is adopted, the requirements of Clause 2.2 and of Clauses 2.6 to 2.8 as appropriate, shall also apply.

2.6 DESIGN FOR DURABILITY

The structure and its component members shall be designed for durability in accordance with the requirements of Section 4.

2.7 DESIGN FOR FIRE RESISTANCE

The structure and its component members shall be designed for the appropriate fire resistance in accordance with Section 5.

2.8 OTHER DESIGN REQUIREMENTS

Requirements such as fatigue, progressive collapse and any special performance requirements shall be considered where relevant and if significant, shall be taken into account in the design of the structure in accordance with the principles of this Standard and appropriate engineering principles.

The design of bridges for loads resulting from floods or collision shall be carried out in accordance with HB77.

Where seismic actions are a consideration, the additional requirements of Appendix A shall apply.

SECTION 3 LOADS AND LOAD COMBINATIONS FOR STABILITY, STRENGTH AND SERVICEABILITY

3.1 LOADS AND OTHER ACTIONS

3.1.1 Loads

The design of a structure for stability, strength and serviceability shall take account of the action effects directly arising from the following loads:

- (a) For structures generally, the dead and live, wind, snow and earthquake loads specified in AS 1170.1, AS 1170.2, AS 1170.3 and AS 1170.4 respectively.
- (b) For housing, the wind loads specified in AS 4055 may be used, if applicable.
- (c) For bridges, if applicable, loads specified in HB77.
- (d) For retaining structures, earth pressure and liquid pressure, as applicable.
- (e) Accidental loading, if applicable.
- (f) Any additional load that may be required.

3.1.2 Construction loads

Loading conditions, which may arise from construction activities and which adversely affect the requirements for stability, strength or serviceability, shall be taken into account. If appropriate, the values assumed for design purposes shall be specified (see also Clause 19.6.2).

3.1.3 Other actions

Any action which may significantly affect the stability, strength or serviceability of the structure, including but not limited to the following, shall be taken into account:

- (a) Foundation movements.
- (b) Temperature changes and gradients.
- (c) Axial shortening.
- (d) Dynamic effects.
- (e) Shrinkage or expansion of concrete during setting or subsequently.
- (f) Creep of concrete.

The value of any of the above actions shall be appropriate to the design state being considered.

3.2 LOAD COMBINATIONS FOR STABILITY DESIGN

The design action effects and the design resistance effects for stability design shall be determined as follows:

- (a) The loads and other actions determined from Clause 3.1 shall be subdivided into components tending to cause instability and components tending to resist instability.
- (b) The design action effect shall be calculated from the components of the loads and other actions tending to cause instability, factored and combined in accordance with Clause 3.3.
- (c) The design resistance effect shall be calculated from 0.8 times the components of the unfactored loads and other actions tending to resist instability.

3.3 LOAD COMBINATIONS FOR STRENGTH DESIGN

3.3.1 Structures other than bridges

The design load for strength design of structures other than bridges, shall be determined from the load combinations for the strength limit states given in AS 1170.1, except that the combination

$$1.25G + W_u + \psi_c Q$$

may be replaced by the more severe of—

$$1.4G; \text{ and}$$

$$1.1G + W_u + \psi_c Q$$

Where applicable, the prestressing force (P) shall be included with a load factor of unity in each load combination, except for the case of dead load plus prestress at transfer, when the more severe of—

$$1.15G + 1.15P; \text{ and}$$

$$0.8G + 1.15P$$

shall apply (see also Clause 7.6.7).

3.3.2 Bridges

Where applicable, the design loads for the strength design of bridges shall be determined from the load combinations given in HB77.

3.4 LOAD COMBINATIONS FOR SERVICEABILITY DESIGN

The design load for serviceability design for deflection shall be taken from the appropriate combinations of factored loads for short-term and long-term effects given in AS 1170.1. Where applicable, the prestressing force (P) shall be included with a load factor of unity in all load combinations (see also Clause 7.6.7).

3.5 LOAD COMBINATIONS FOR FIRE-RESISTANCE DESIGN

The combination of factored loads to be used for fire resistance in conjunction with Clause 5.8 and 5.9 shall be as given in AS 1170.1 for the fire limit state.

SECTION 4 DESIGN FOR DURABILITY

4.1 APPLICATION OF SECTION

The requirements of this Section apply to plain, reinforced, and prestressed, concrete structures and members with a design life of 40 to 60 years.

NOTES:

- 1 More stringent requirements would be appropriate for structures with a design life in excess of 60 years (e.g. monumental structures), while some relaxation of the requirements may be acceptable for structures with a design life less than 40 years (e.g. temporary structures).
- 2 Durability is a complex topic and compliance with these requirements may not be sufficient to ensure a durable structure. The Commentary (AS 3600 Supp 1) contains background to, and further guidance on, the provisions of this Section.

4.2 DESIGN FOR DURABILITY

4.2.1 General

Durability shall be allowed for in design by determining the exposure classification in accordance with Clause 4.3 and, for that exposure classification, complying with the appropriate requirements for—

- (a) concrete quality and curing, in accordance with Clauses 4.4 to 4.6;
- (b) chemical content restrictions, in accordance with Clause 4.9; and
- (c) cover, in accordance with Clause 4.10.

4.2.2 Additional requirements

In addition to the requirements specified in Clause 4.2.1—

- (a) members subject to abrasion from traffic (e.g. pavements and floors) shall satisfy the requirements of Clause 4.7; and
- (b) members subject to cycles of freezing and thawing shall satisfy the requirements of Clause 4.8.

4.3 EXPOSURE CLASSIFICATION

4.3.1 General

The following is applicable:

- (a) The exposure classification for a surface of a member shall be determined from Table 4.3 and Figure 4.3.
- (b) For determining concrete quality requirements in accordance with Clauses 4.4 to 4.6 and Clause 4.9, as appropriate, the exposure classification for the member shall be taken as the most severe exposure of any of its surfaces.
- (c) For determining cover requirements for corrosion protection in accordance with Clause 4.10.3, the exposure classification shall be taken as the classification for the surface from which the cover is measured.

NOTE: In Table 4.3, classifications A1, A2, B1, B2 and C represent increasing degrees of severity of exposure, while classification U represents an exposure environment not specified in the table but for which a degree of severity of exposure should be appropriately assessed. Protective surface coatings may be taken into account in the assessment of the exposure classification.

4.3.2 Concession for exterior exposure of a single surface

Where the exterior exposure is essentially only one surface of a member, concrete of the next lower grade than would otherwise be required by Clause 4.4 or 4.5 may be used, provided that the cover from that surface is increased by—

- (a) 20 mm from the value required by Clause 4.10.3.2; or
- (b) 15 mm from the value required by Clause 4.10.3.4.

TABLE 4.3
EXPOSURE CLASSIFICATIONS

Surface and exposure environment	Exposure classification	
	Reinforced or prestressed concrete members (Note 1)	Plain concrete members (Note 1)
1 Surface of members in contact with the ground		
(a) Members protected by a damp-proof membrane	A1	A1
(b) Residential footings in non-aggressive soils	A1	A1
(c) Other members in non-aggressive soils	A2	A1
(d) Members in aggressive soils (Note 2)	U	U
2 Surfaces of members in interior environments		
(a) Fully enclosed within a building except for a brief period of weather exposure during construction;	A1	A1
(b) In industrial buildings, the member being subject to repeated wetting and drying	B1	A1
3 Surfaces of members in above-ground exterior environments		
In areas that are:		
(a) Inland (> 50 km from coastline) environment being—		
(i) non-industrial and arid climatic zone (Notes 3 and 4)	A1	A1
(ii) non-industrial and temperate climatic zone	A2	A1
(iii) non-industrial and tropical climatic zone	B1	A1
(iv) industrial and any climatic zone	B1	A1
(b) Near-coastal (1 km to 50 km from coastline), any climatic zone	B1	A1
(c) Coastal (Up to 1 km from coastline but excluding tidal and splash zones) (Note 5), any climatic zone	B2	A1
4 Surfaces of members in water		
(a) In fresh water	B1	A1
(b) In sea water—		
(i) permanently submerged	B2	U
(ii) in tidal or splash zones	C	U
(c) In soft or running water	U	U
5 Surfaces of members in other environments		
Any exposure environment not otherwise described in Items 1 to 4	U	U

NOTES:

- 1 In this context, reinforced concrete includes any concrete containing metals that rely on the concrete for protection against environmental degradation. Plain concrete members containing reinforcement or other metallic embedment should, therefore, be treated as reinforced members, when considering durability.
- 2 Permeable soils with a pH < 4.0, or with ground water containing more than 1 g per litre of sulphate ions, would be considered aggressive. Salt-rich soils in arid areas should be considered as exposure classification C.
- 3 The climatic zones referred to are those given in Figure 4.3, which is a simplified version of Plate 8 of the Bureau of Meteorology publication 'Climate of Australia', 1982 Edition.
- 4 Industrial refers to areas that are within 3 km of industries that discharge atmospheric pollutants.
- 5 For the purpose of this Table, the coastal zone includes locations within 1 km of the shoreline of large expanses of salt water (e.g. Port Phillip Bay, Sydney Harbour east of the Spit and Harbour Bridges, Swan River west of the Narrows Bridge). Where there are strong prevailing winds or vigorous surf, the distance should be increased beyond 1 km and higher levels of protection should be considered. Proximity to small salt water bays, estuaries and rivers may be disregarded.

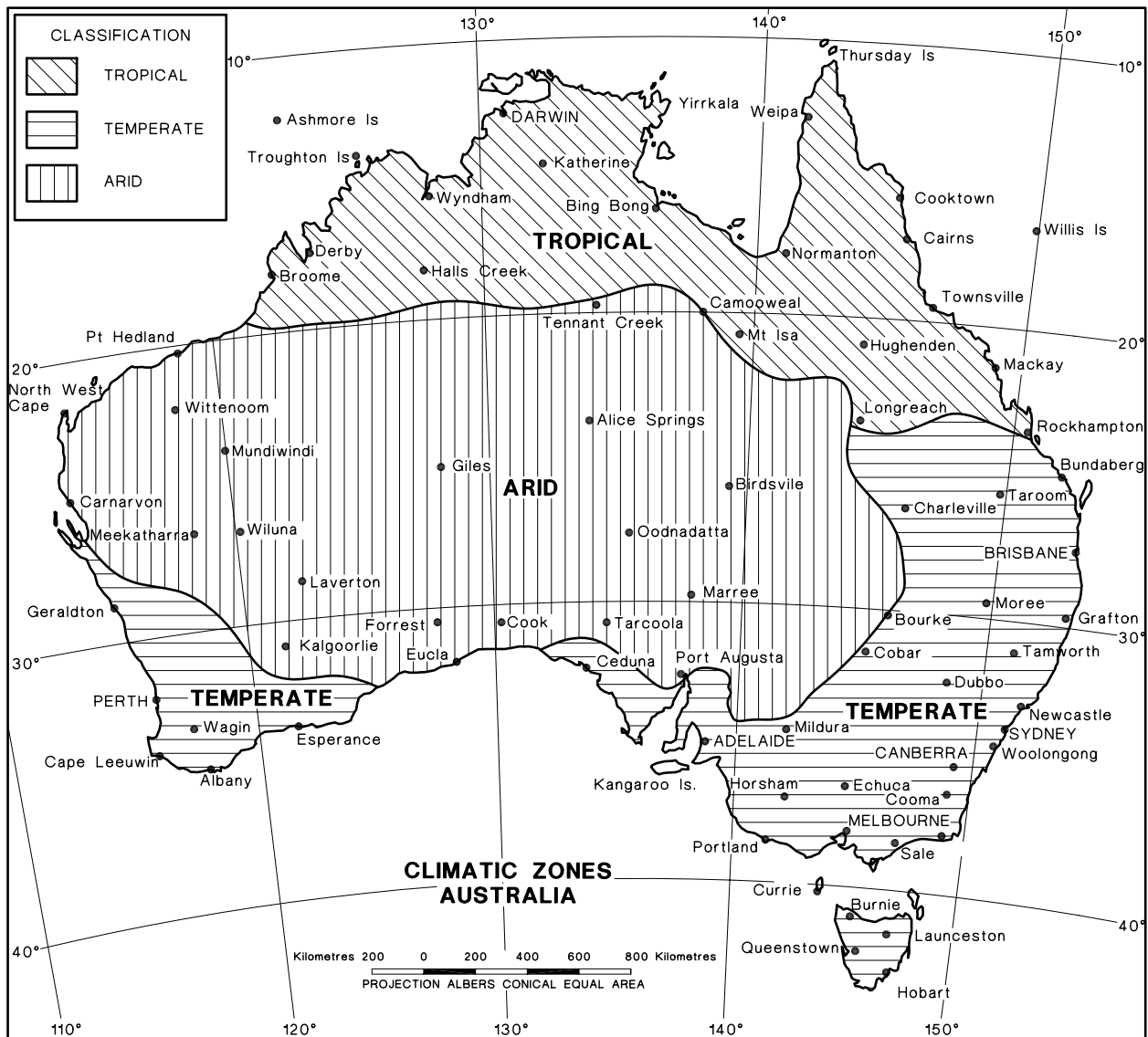

Note: 'Woolongong', on the east coast of Australia, should read 'Wollongong'.

FIGURE 4.3 CLIMATIC ZONES REFERRED TO IN TABLE 4.3

4.4 REQUIREMENTS FOR CONCRETE FOR EXPOSURE CLASSIFICATIONS A1 AND A2

Members subject to exposure classifications A1 or A2 shall be initially cured continuously for at least three days under ambient conditions, or cured by accelerated methods, so that the average compressive strength of the concrete at the completion of curing is not less than 15 MPa.

Concrete in the member shall have an f'_c not less than—

- 20 MPa for exposure classification A1; or
- 25 MPa for exposure classification A2.

4.5 REQUIREMENTS FOR CONCRETE FOR EXPOSURE CLASSIFICATIONS B1, B2 AND C

Members subject to exposure classifications B1, B2 or C shall be initially cured continuously for at least 7 days under ambient conditions, or cured by accelerated methods so that the average compressive strength of the concrete at the completion of curing is not less than 20 MPa for exposure classification B1, 25 MPa for exposure classifications B2, 32 MPa for exposure classification C and 40 MPa for 65 MPa concrete.

Concrete in the member shall have an f'_c not less than—

- (a) 32 MPa for exposure classification B1;
- (b) 40 MPa for exposure classification B2; or
- (c) 50 MPa for exposure classification C.

In addition, for special-class concrete, the minimum cement content and the cement type shall be specified.

Where the requirement of Item (c) cannot be satisfied due to inadequate aggregate strength, concrete with f'_c not less than 40 MPa may be used for exposure classification C, provided that the cement content of the mix is not less than 470 kg/m³ and the covers required by Clause 4.10.3 are increased by 10 mm.

4.6 REQUIREMENTS FOR CONCRETE FOR EXPOSURE CLASSIFICATION U

Concrete in members subject to exposure classification U shall be specified to ensure durability under the particular exposure environment.

4.7 ADDITIONAL REQUIREMENTS FOR ABRASION

In addition to the other durability requirements of this Section, concrete for members subject to abrasion from traffic shall have a characteristic compressive strength not less than the applicable value given in Table 4.7.

TABLE 4.7
STRENGTH REQUIREMENTS FOR ABRASION

Member and/or traffic	Minimum characteristic strength (f'_c)
	MPa
Footpaths and residential driveways	20
Commercial and industrial floors not subject to vehicular traffic	25
Pavements or floors subject to:	
(a) Light pneumatic-tyred traffic (vehicles up to 3 t gross mass)	25
(b) Medium or heavy pneumatic-tyred traffic (vehicles heavier than 3 t gross mass)	32
(c) Non-pneumatic-tyred traffic	40
(d) Steel-wheeled traffic	To be assessed but not less than 40

NOTE: f'_c refers to the strength of the wearing course.

4.8 ADDITIONAL REQUIREMENTS FOR FREEZING AND THAWING

In addition to the other durability requirements of this Section, where the surface exposure includes exposure to cycles of freezing and thawing, concrete in the member shall—

- (a) have an f'_c not less than—
 - (i) 32 MPa for occasional exposure (< 25 cycles p.a.); or
 - (ii) 40 MPa for frequent exposure (\geq 25 cycles p.a.); and
- (b) contain a percentage of entrained air not outside the following ranges—
 - (i) for 10 mm to 20 mm nominal size aggregate8% to 4%; or
 - (ii) for 40 mm nominal size aggregate6% to 3%,

where the percentage of entrained air is determined in accordance with AS 1012.4.

4.9 RESTRICTIONS ON CHEMICAL CONTENT IN CONCRETE

Chemical admixtures added to concrete to be used in structures or elements designed in accordance with this Standard shall comply with AS 1478.1. In addition, strongly ionized salts, such as chlorides or nitrates, shall not be added unless it is demonstrated that the resulting concentration of soluble ions does not adversely affect the durability of the concrete, or the durability of the reinforcement, tendons, ducts or cast-in inserts embedded in it.

4.10 REQUIREMENTS FOR COVER TO REINFORCING STEEL AND TENDONS

4.10.1 General

The cover to reinforcing steel and tendons shall be the greatest of the values determined from Clauses 4.10.2 and 4.10.3, as appropriate, unless exceeded by the covers required by Section 5 for fire resistance.

4.10.2 Cover for concrete placement

Designers shall specify appropriate covers to ensure that the concrete can be satisfactorily placed and compacted around the reinforcement, tendons or ducts, or any combination of these, in accordance with the requirements of Clause 19.1.3.

In the determination of an appropriate cover, consideration shall be given to the size and shape of the member; the size and configuration of the reinforcement and, if present, the tendons or ducts; and the aggregate size, the workability of the concrete and the direction of concrete placement.

Where the presence of ducts is not a consideration, covers to reinforcement or tendons greater than their nominal size or the maximum nominal aggregate size, whichever is larger, shall be deemed to satisfy the requirements of the first two paragraphs of the Clause.

4.10.3 Cover for corrosion protection

4.10.3.1 General

For corrosion protection, the cover shall be not less than the appropriate value given in Clauses 4.10.3.2 to 4.10.3.5.

4.10.3.2 Standard formwork and compaction

Where concrete is cast in formwork complying with AS 3610 and compacted in accordance with Clause 19.1.3 of this Standard, the cover shall be not less than the value given in Table 4.10.3.2 appropriate to the exposure classification and f'_c .

4.10.3.3 *Cast against ground*

Where concrete is cast on or against ground and compacted in accordance with Clause 19.1.3, the cover to a surface in contact with the ground shall be as given in Table 4.10.3.2 but increased by—

- (a) 10 mm if the concrete surface is protected by a damp-proof membrane; or
- (b) 20 mm otherwise.

4.10.3.4 *Rigid formwork and intense compaction*

Where concrete is precast in rigid steel forms and subjected to intense compaction, such as obtained with vibrating tables or form vibrators, the cover shall be not less than the value given in Table 4.10.3.4, appropriate to the exposure classification and f'_c .

4.10.3.5 *Structural members manufactured by spinning or rolling*

Where structural members are manufactured by spinning or rolling concrete having a water/cement ratio less than 0.35, and provided that no negative tolerance is allowed on the fixing of reinforcement, the cover for corrosion protection shall be not less than the value given in Table 4.10.3.5 for the appropriate exposure classification.

TABLE 4.10.3.2
REQUIRED COVER WHERE STANDARD FORMWORK AND
COMPACTION ARE USED

Exposure classification	Required cover, mm				
	Characteristic strength (f'_c)				
	20 MPa	25 MPa	32 MPa	40 MPa	≥ 50 MPa
A1	20	20	20	20	20
A2	(50)	30	25	20	20
B1	—	(60)	40	30	25
B2	—	—	(65)	45	35
C	—	—	—	(70)	50

NOTES:

- 1 Bracketed figures are the appropriate covers when the concession given in Clause 4.3.2, relating to the strength grade permitted for a particular exposure classification, is applied.
- 2 Increased values are required if Clause 4.10.3.3 applies.

TABLE 4.10.3.4
REQUIRED COVER WHERE RIGID FORMWORK AND INTENSE
COMPACTION ARE USED

Exposure classification	Required cover, mm				
	Characteristic strength (f'_c)				
	20 MPa	25 MPa	32 MPa	40 MPa	≥ 50 MPa
A1	15	15	15	15	15
A2	(35)	20	15	15	15
B1	—	(45)	30	25	20
B2	—	—	(50)	35	25
C	—	—	—	(55)	40

NOTE: Bracketed figures are the appropriate covers when the concession given in Clause 4.3.2, relating to the strength grade permitted for a particular exposure classification, is applied.

TABLE 4.10.3.5
REQUIRED COVER FOR SPUN
OR ROLLED MEMBERS

Exposure classification	Cover mm
A1 & A2	10
B1	15
B2	20
C	25

SECTION 5 DESIGN FOR FIRE RESISTANCE

5.1 SCOPE OF SECTION

This Section sets out the requirements for the design of reinforced and prestressed concrete structures and members to resist the effects of fire and gives methods for determining the fire-resistance levels required by the relevant Authority.

5.2 DEFINITIONS

For the purpose of this Section, the following definitions apply:

5.2.1 Fire-resistance level

The fire-resistance periods for structural adequacy, integrity and insulation expressed in that order, as required by the relevant Authority.

5.2.2 Fire-resistance period

The time, in minutes, for a member to reach the appropriate failure criterion specified in AS 1530.4, if tested for fire in accordance with that Standard.

5.2.3 Fire-separating function

The function served by the boundary elements of a fire compartment, which are required to have a fire-resistance level, of preventing a fire in that compartment from spreading to adjoining compartments.

NOTES:

- 1 When tested in accordance with AS 1530.4, prototypes of such members are exposed to fire from only one direction at a time and are assumed to be similarly exposed for the purpose of interpreting this Section.
- 2 Roofs, walls and floors may serve this function.

5.2.4 Hollow-core slab or wall

A slab or wall having mainly a uniform thickness and containing essentially continuous voids, where the thickness of concrete between adjacent voids and the thickness of concrete between any part of a void and the nearest surface is not less than the greater of one fifth the required effective thickness of the slab or wall and 25 mm.

5.2.5 Insulation

The ability of a fire-separating member, such as a wall or floor, to limit the surface temperature on one side of the member when exposed to fire on the other side.

5.2.6 Integrity

The ability of a fire-separating member to resist the passage of flames or hot gases through the member when exposed to fire on one side.

5.2.7 Loadbearing member

A member intended to support or transmit vertical loads additional to its own weight and where the design axial force at mid-height of the member is greater than $0.03 f'_c A_g$.

5.2.8 Ribbed slab

A slab incorporating parallel ribs spaced at not greater than 1500 mm centre-to-centre in one or two directions.

5.2.9 Structural adequacy

The ability of a member to maintain its structural function when exposed to fire.

5.3 DESIGN REQUIREMENTS

5.3.1 General

A member shall be designed to have a fire-resistance period for each of structural adequacy, integrity and insulation not less than the required fire-resistance level.

5.3.2 Joints

Joints between members or between adjoining parts shall be constructed so that the fire-resistance level of the whole assembly is not less than that required for the member.

5.3.3 Spalling of beams and columns

NOTE: Standards Australia is not prepared at present to specify requirements for the prevention of spalling of concrete from beams or columns exposed to fire; however, reference may be made to BS 8110.2, in relation to this topic.

5.3.4 Methods for determining fire-resistance periods

The fire-resistance periods for a member shall be determined by either —

- (a) proportioning the member in accordance with Clauses 5.4 to 5.7, 5.11 and 5.12 as appropriate; or
- (b) the methods given in Clause 5.8 or Clause 5.9.

5.4 FIRE-RESISTANCE PERIODS FOR BEAMS

5.4.1 Insulation and integrity for beams

Fire-resistance periods for insulation and integrity are not generally relevant to beams but, where required, are met by satisfying the corresponding resistance periods for structural adequacy.

5.4.2 Structural adequacy for beams incorporated in roof or floor systems

A beam, whose upper surface is integral with or protected by a slab complying with Clause 5.5, which has a web of uniform width or which tapers uniformly over its depth, has one of the fire-resistance periods for structural adequacy shown in Figures 5.4.2(A) and 5.4.2(B), if it is proportioned so that —

- (a) the beam width, measured at the centroid of the lowest level of longitudinal bottom reinforcement; and
- (b) the cover to the longitudinal bottom reinforcement

are not less than the values for that period obtained from —

- (i) Figure 5.4.2(A), for simply supported beams; or
- (ii) Figure 5.4.2(B), for continuous beams.

Cover to tendons shall be increased from the relevant values for longitudinal bottom reinforcement obtained from Figure 5.4.2(A) or Figure 5.4.2(B), as appropriate, by 5 mm for periods of 30 and 60 min and by 10 mm for periods of 90 min and greater.

For the purpose of this Clause, a beam shall be considered continuous if, under imposed load, it is flexurally continuous at least at one end.

5.4.3 Structural adequacy for beams exposed to fire on all sides

A beam of approximately rectangular cross-section, which can be exposed to fire on all four sides, has a particular fire-resistance period for structural adequacy if it is proportioned so that —

- (a) the total depth of the beam is not less than the least value of b_w for that period, obtained from Figure 5.4.2(A) or Figure 5.4.2(B) as appropriate;

- (b) the cross-sectional area of the beam is not less than twice the area of a square with a side equal to b_w determined as for Item (a); and
- (c) the cover is not less than the value for that period determined using the minimum dimension of the beam for b_w in the relevant figure and applies to all longitudinal reinforcement or tendons.

5.4.4 Increasing fire-resistance periods of beams by insulating materials

For beams, the fire-resistance periods may be increased, in accordance with Clause 5.10, by the application of insulating material to the surfaces exposed to fire.

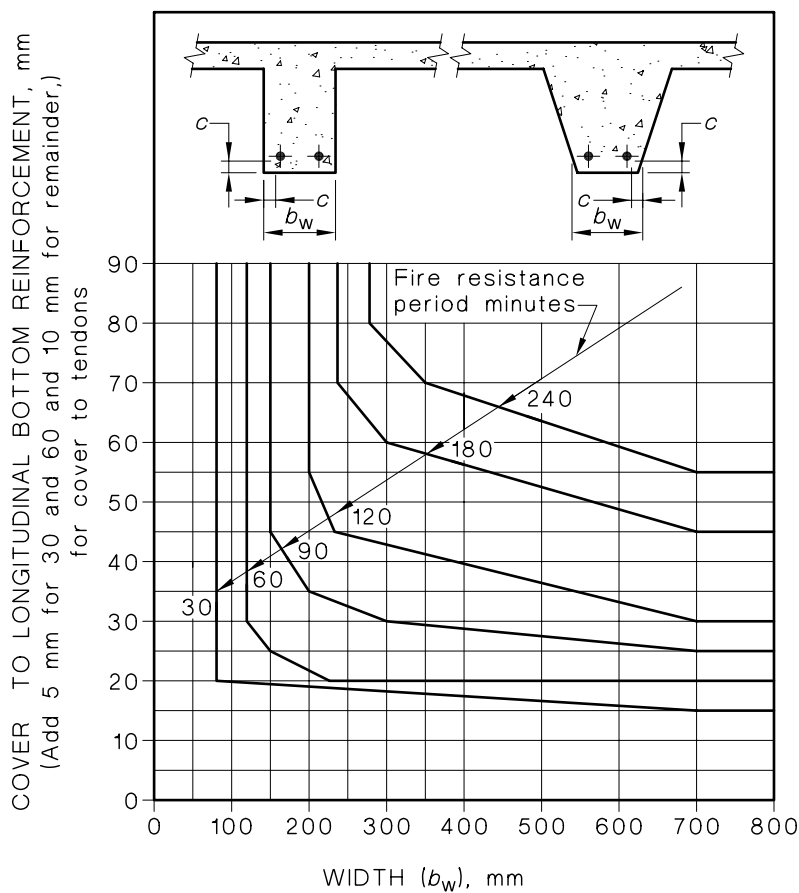

FIGURE 5.4.2(A) STRUCTURAL ADEQUACY REQUIREMENTS — SIMPLY SUPPORTED BEAMS

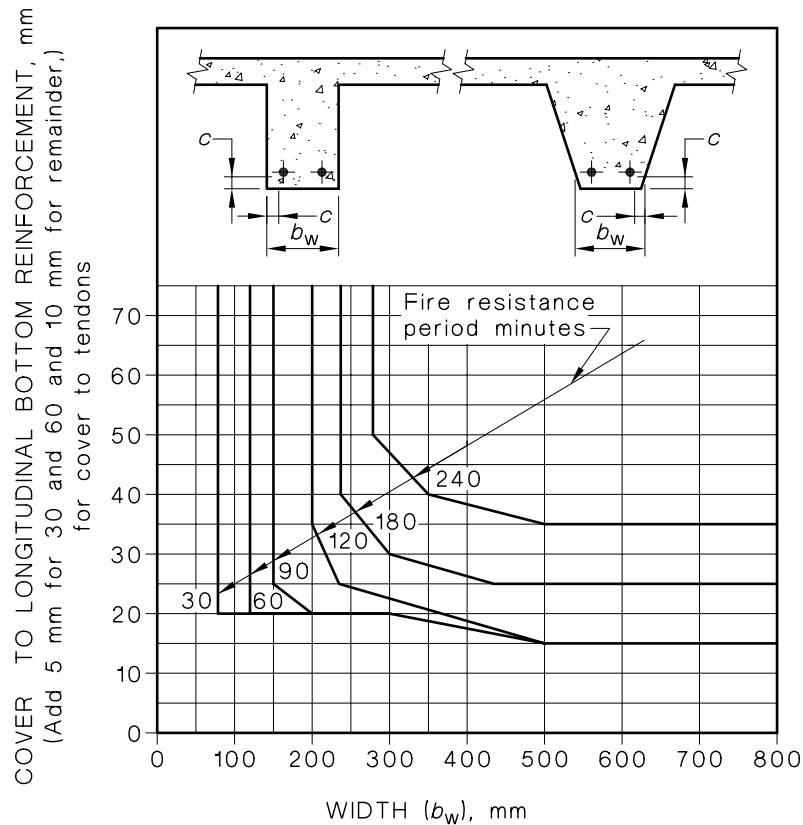

FIGURE 5.4.2(B) STRUCTURAL ADEQUACY REQUIREMENTS — CONTINUOUS BEAMS

5.5 FIRE-RESISTANCE PERIODS FOR SLABS

5.5.1 Insulation for slabs

A slab has one of the fire-resistance periods for insulation given in Table 5.5.1 if the effective thickness of the slab is not less than the corresponding value given in the table.

The effective thickness of the slab to be used in Table 5.5.1 shall be taken as follows:

- For solid slabs, the actual thickness.
- For hollow-core slabs, the net cross-sectional area divided by the width of the cross-section.
- For ribbed slabs, the thickness of the solid slab between the webs of adjacent ribs.

TABLE 5.5.1

MINIMUM EFFECTIVE THICKNESS FOR INSULATION

Fire-resistance minutes	Effective thickness mm
30	60
60	80
90	100
120	120
180	150
240	170

5.5.2 Integrity for slabs

A slab has a particular fire-resistance period for integrity if it meets the requirements for both insulation and structural adequacy for that period.

5.5.3 Structural adequacy for slabs

For the purpose of this Clause, a slab shall be considered continuous if, under imposed load, it is flexurally continuous at least at one end.

The fire-resistance period for structural adequacy for a slab shall be determined in accordance with either of the following, as appropriate.

- (a) A solid or hollow-core slab has one of the fire-resistance periods for structural adequacy given in Table 5.5.3(A) if, for the appropriate support conditions, the cover to the bottom reinforcement and tendons is not less than the corresponding value given in the table.
- (b) A ribbed slab has a particular fire-resistance period for structural adequacy if, for the appropriate support conditions and fire-resistance period, it is proportioned so that —
 - (i) the width of the ribs and the cover to the longitudinal bottom reinforcement in them are not less than those given in Table 5.5.3(B); and
 - (ii) the cover to the bottom reinforcement in the slab between the ribs is not less than that determined in accordance with Item (a) above.

A rib incorporating tendons has a fire-resistance period for structural adequacy determined in accordance with Item (i) above, if the cover to tendons is 10 mm greater than the appropriate value for reinforcement.

5.5.4 Increasing fire-resistance periods of slabs by insulating materials

For slabs, the fire-resistance periods may be increased, in accordance with Clause 5.10, by the addition of toppings and/or the application of insulating materials to the soffit.

Other methods (e.g. addition of insulating materials in hollow cores) may be used but any increase afforded shall be determined in accordance with Clause 5.8.

TABLE 5.5.3(A)
FIRE-RESISTANCE REQUIREMENTS FOR STRUCTURAL ADEQUACY OF SLABS

Fire-resistance period minutes	Cover to bottom reinforcement or tendons mm			
	Simply supported slabs		Continuous slabs	
	Reinforcement	Tendons	Reinforcement	Tendons
30	15	20	10	15
60	20	25	15	20
90	25	35	15	25
120	30	40	15	25
180	45	55	25	35
240	55	65	35	45

NOTE: For simply supported two-way slabs, the values for cover may be reduced by 5 mm.

TABLE 5.5.3(B)
FIRE-RESISTANCE REQUIREMENTS FOR STRUCTURAL
ADEQUACY OF RIBS

Fire-resistance period minutes	Simply supported one-way and two-way ribbed slabs		Continuous one-way and two-way ribbed slabs	
	Minimum width of rib mm	Cover mm	Minimum width of rib mm	Cover mm
30	80	15	70	15
60	110	25	75	20
90	135	35	110	25
120	150	45	125	35
180	175	55	150	45
240	200	65	175	55

NOTE: Cover is measured to the longitudinal bottom reinforcement.

5.6 FIRE-RESISTANCE PERIODS FOR COLUMNS

5.6.1 General

Fire-resistance periods for a column shall be determined in accordance with either —

- (a) Clauses 5.6.2 and 5.6.3 if the column —
- (i) can be exposed to fire on all sides; or
 - (ii) is built into or forms part of a wall not capable of serving a fire-separating function; or
 - (iii) is built into or forms part of a wall having a fire-separating function but which has a fire-resistance period for structural adequacy less than that required for the column; or
 - (iv) is built into and protrudes by more than the cover to the longitudinal steel beyond the fire-exposed face of a wall having a fire-separating function; or
- (b) Clause 5.7 in all other instances.

5.6.2 Insulation and integrity for columns

Fire-resistance periods for insulation and integrity do not apply to columns described in Clause 5.6.1(a). Where a column serves a fire-separating function and Clause 5.6.1(a) is not applicable, the fire resistance periods for insulation and integrity shall be determined in accordance with Clauses 5.7.2 and 5.7.3.

5.6.3 Structural adequacy for columns

5.6.3.1 General

The structural adequacy of a column shall be determined either by Clause 5.6.3.2 or the deemed-to-satisfy rules given in Clause 5.6.3.3.

5.6.3.2 Structural adequacy by calculation

The fire resistance period (FRP), in minutes, for structural adequacy of a reinforced concrete column, of an aspect ratio within the range 1:1 to 1:8, minimum dimension within the range 150 mm to 1000 mm, cover to main reinforcement in the range 20 mm to 40 mm, constructed of concrete with f'_c in the range 20 MPa to 50 MPa and with L_c not less than $5 D_c$ shall be determined from the following expression:

$$\text{FRP} = \left(k f'_c{}^{1.3} D_c{}^{3.3} D_g{}^{1.8} \right) / \left(10^5 N^{*1.5} L_c{}^{0.9} \right)$$

where

k = a coefficient dependent on the steel ratio

= 1.5 when $A_s/A_g < 0.025$; or

= 1.7 when $A_s/A_g \geq 0.025$

f'_c = the characteristic compressive strength of concrete, in megapascals

D_c = the smaller column dimension of a rectangular column, in millimetres

D_g = the greater column dimension of a rectangular column, in millimetres

N^* = the design axial force for the fire limit state, in kilonewtons, but not less than $0.4 N_{uo}$

L_e = the effective length of the column, in millimetres

For columns with cross-section dimensions greater than 1000 mm, the FRP shall be calculated assuming D_c and D_g have maximum values of 1000 mm.

For columns with L_e less than $5 D_c$, the FRP shall be calculated assuming $L_e = 5 D_c$.

For columns of circular or regular polygonal cross-section, D_c and D_g in the above equation shall be taken as equal to $\sqrt{A_g}$. For prestressed columns, the above equation may be used, provided the cover to tendons is not less than 45 mm or the cover required for durability, whichever is the larger.

5.6.3.3 Structural adequacy by proportioning

A column shall be deemed to have one of the fire-resistance periods for structural adequacy shown in Figure 5.6.3, if it is proportioned so that the minimum cross-sectional dimension and the cover to the longitudinal reinforcement are not less than the values obtained from that Figure.

For any particular fire-resistance period, the cover to tendons shall be 10 mm greater than the relevant values for longitudinal reinforcement obtained from Figure 5.6.3.

For columns of circular cross-section, or regular polygonal cross-section with more than four faces, the dimension 'b' in Figure 5.6.3 shall be taken as the diameter of circular columns, or the diameter of the circumscribed circle passing through the external corners of polygonal columns.

5.6.4 Increasing fire-resistance periods for columns by insulating materials

For columns, the fire-resistance periods may be increased, in accordance with Clause 5.10, by the application of insulating material to the faces exposed to fire.

5.7 FIRE-RESISTANCE PERIODS FOR WALLS

5.7.1 General

The fire-resistance periods for a wall shall be determined in accordance with either —

- (a) Clauses 5.7.2 to 5.7.4 if the wall has a fire-separating function; or
- (b) Clause 5.6 in all other instances.

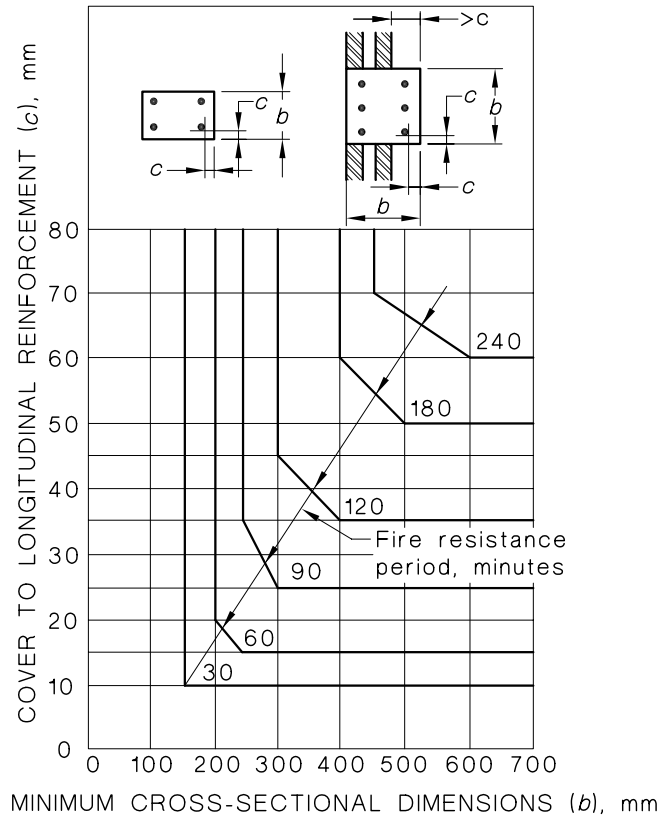

FIGURE 5.6.3 STRUCTURAL ADEQUACY REQUIREMENT — COLUMNS

5.7.2 Insulation for walls

A wall has one of the fire-resistance periods for insulation given in Table 5.7.2 if the effective thickness of the wall is not less than the corresponding value given in the table.

The effective thickness of the wall to be used in Table 5.7.2 shall be taken as follows:

- (a) For solid walls, the actual thickness.
- (b) For hollow-core walls the net cross-sectional area divided by the length of the cross-section.

**TABLE 5.7.2
MINIMUM EFFECTIVE THICKNESS FOR INSULATION**

Fire-resistance period minutes	Effective thickness mm
30	60
60	80
90	100
120	120
180	150
240	170

5.7.3 Integrity for walls

A wall has the stated fire-resistance period for integrity if it meets the requirements for both insulation and structural adequacy for that period.

5.7.4 Structural adequacy for walls

A laterally supported wall has the required fire-resistance period for structural adequacy if the following are satisfied:

- (a) The wall complies with the requirements of Clause 11.2.
- (b) Its effective thickness is not less than the thickness required by Clause 5.7.2 for that period.
- (c) If $N^* \leq 0.03 f'_c A_g$ and H_{we}/t_w is not greater than 50.
- (d) If $N^* > 0.03 f'_c A_g$ —
 - (i) H_{we}/t_w is not greater than 20; and
 - (ii) the cover from the fire-exposed face to the vertical reinforcement or tendons is not less than the corresponding cover given in Table 5.7.4 for that period.

For the purpose of Items (c) and (d) above, the following apply:

- (A) N^* is the design axial force at the mid-height of the wall.
- (B) H_{we} is calculated in accordance with the principles of Section 10, or from Clause 11.4.3, with rotational restraint at the support, if any, being provided by a member outside the fire compartment including a continuation of the wall itself. If the wall spans horizontally, H_{wu} shall be taken as equal to L_1 .
- (C) If the wall is laterally supported on all four sides, H_{we} shall be determined—
 - (1) in accordance with Item (B) if $H_{wu} \leq L_1$; or
 - (2) by substituting L_1 for H_{wu} in Item (B) if $H_{wu} > L_1$, the rotational restraint provided being determined for the supports in the direction of L_1 .

**TABLE 5.7.4
MINIMUM COVER TO VERTICAL REINFORCEMENT AND
TENDONS FOR STRUCTURAL ADEQUACY OF WALLS**

Fire-resistance period minutes	Cover mm	
	To reinforcement	To tendons
30	20	30
60	20	30
90	35	30
120	40	30
180	45	35
240	50	45

5.7.5 Increasing fire-resistance periods for walls by insulating materials

For walls, the fire-resistance periods may be increased, in accordance with Clause 5.10, by the application of insulating materials to the face exposed to fire.

Other methods (e.g. addition of insulation materials in hollow cores) may be used. Any increase afforded shall be determined in accordance with Clause 5.8.

5.8 FIRE-RESISTANCE PERIODS FROM FIRE TESTS

5.8.1 General

Fire tests on members shall be carried out in accordance with AS 1530.4, and the results applied in accordance with this Clause, as appropriate.

5.8.2 Loadbearing members tested under load

5.8.2.1 *Application of test results*

For prototype loadbearing members tested under load, in accordance with AS 1530.4, the fire test results shall be applied in accordance with either Clause 5.8.2.2 or 5.8.2.3, as appropriate.

5.8.2.2 *Members identical to the prototype*

The results of fire tests on a prototype may be applied directly to an identical member or system incorporated in a building structure.

For the purpose of this Clause, an incorporated member or system shall be considered identical to the prototype if —

- (a) it is of the same shape, size and form of construction as the prototype;
- (b) it is composed of materials having relevant properties within the variability range of those used in the prototype;
- (c) it has the same type and similar degree of flexural restraint and restraint against thermal movements, as the prototype;
- (d) it has thicknesses and covers, in relation to the expected direction of fire exposure, not less than the corresponding thicknesses and covers of the prototype; and
- (e) it has an effective span, or effective length, which does not exceed that of the prototype by more than 3%.

5.8.2.3 *Floor or roof members, or systems, similar to the prototype*

The results of fire tests on a prototype floor or roof member, or system, may be applied to similar members or systems incorporated in a building structure if the test results are suitably modified by appropriate engineering calculations.

The engineering calculations shall take into account variations of the incorporated member or system from that of the prototype including, but not limited to, differences in the effective span; differences in magnitude, or distribution of loading, or both; and differences in the degree of restraint against flexural or thermal movements, or both.

Where the flexural restraint available at either or both ends of a span of the incorporated member or system exceeds the corresponding flexural restraint provided or induced in the prototype during the test, the design positive moment in that span may be reduced by not more than 10% of the excess for each end that the restraint is available.

For the purpose of this Clause, an incorporated member or system shall be considered similar to the prototype member or system provided that —

- (a) the incorporated member or system —
 - (i) is similar in geometry to the prototype;
 - (ii) is of the same form of construction and is composed of materials similar to those used in the prototype; and
 - (iii) has the same type of restraints against flexural, or thermal movements, or both, as provided or induced in the prototype; and

- (b) the calculated stresses in the incorporated member or system, due to the short-term serviceability loads specified in Clause 3.4, do not exceed by more than 20% the calculated stresses in the corresponding sections of the prototype, due to the loads on it at the commencement of heating.

5.8.3 Beams, slabs and columns tested as non-loaded members

Temperatures measured within the cross-section of beams, slabs and columns, tested as non-loaded members in accordance with AS 1530.4, shall be used, in conjunction with a method of calculation given in Clause 5.9, to determine the structural adequacy of the constructed member.

5.9 PREDICTION OF FIRE-RESISTANCE PERIODS

The fire-resistance period of a concrete member may be predicted by methods of calculation provided the methods comply with Specification A2.3 of the Building Code of Australia, using the relevant properties of materials at elevated temperatures as appropriate. The information given in Figures 5.9(A) and 5.9(B) is only valid for reinforcement with yield strengths up to 450 MPa.

Similar information for 500 MPa steels shall be determined by tests, as necessary.

NOTE: Particular consideration should be given to the effects of moment redistribution in a fire situation when Ductility Class L reinforcement is used in critical regions.

5.10 INCREASE OF FIRE-RESISTANCE PERIODS BY USE OF INSULATING MATERIALS

5.10.1 Increase of fire-resistance periods by the addition of insulating materials

5.10.1.1 General

The fire-resistance periods for insulation and structural adequacy of a concrete member may be increased, by the addition to the surface of an insulating material, to provide increased thickness to the member, or greater insulation to the longitudinal reinforcement or tendons, or both.

5.10.1.2 Acceptable forms of insulation

Acceptable forms of insulation include the following:

- (a) Slabs of 1:4 vermiculite concrete or of 1:4 perlite concrete, which are appropriately bonded to the concrete.
- (b) Gypsum-vermiculite plaster or gypsum-perlite plaster, both mixed in the proportion of 0.16 m³ of aggregate to 100 kg of gypsum, in the form of either slabs appropriately bonded to the concrete, or as a sprayed or trowelled application applied in situ.
- (c) Any other fire-protective building board or material, which has been demonstrated to be suitable for the purpose in a standard fire-resistance test.

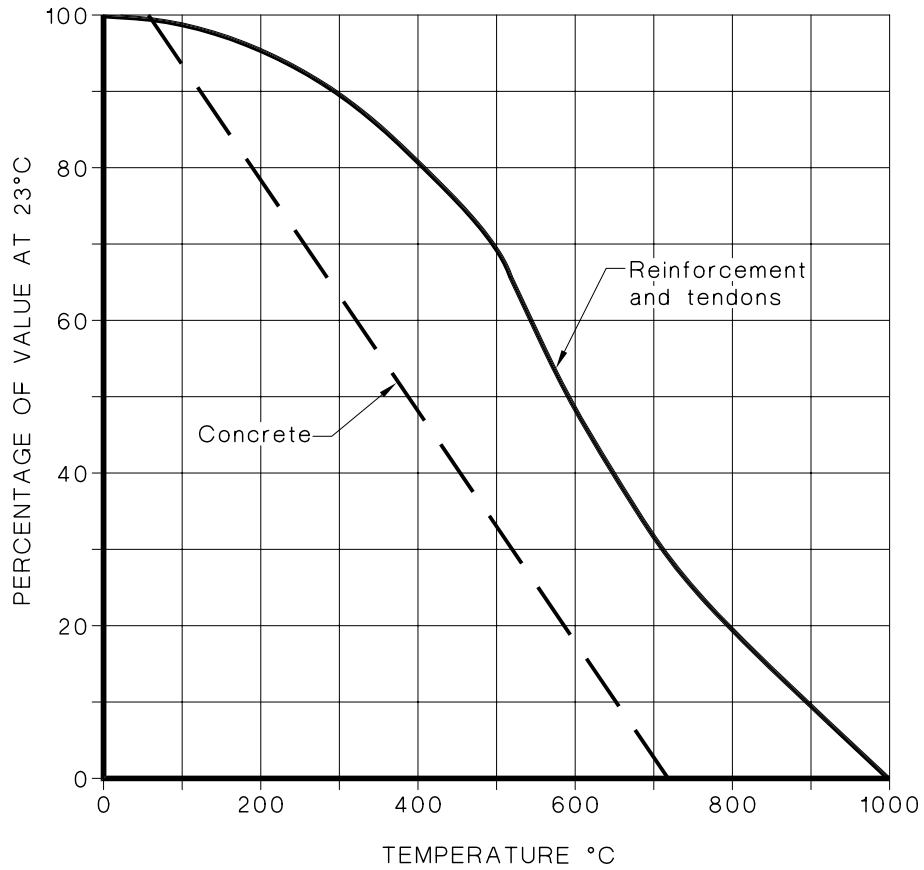

FIGURE 5.9(A) DECREASE OF ELASTIC MODULUS WITH TEMPERATURE

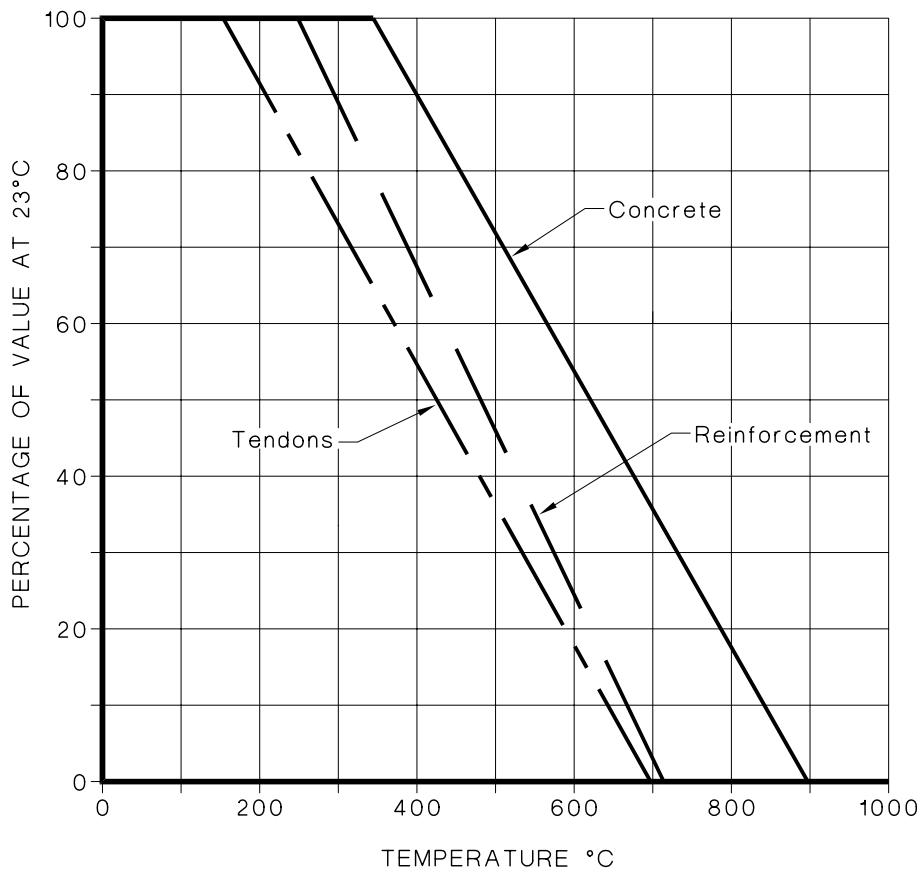

FIGURE 5.9(B) DECREASE OF STRENGTH WITH TEMPERATURE

5.10.1.3 *Thickness of insulating material*

The minimum thickness of insulating material added to attain the required fire-resistance level shall be determined by testing in accordance with AS 1530.4.

In the absence of such testing and only for the materials specified in Clause 5.10.1.2, the minimum thickness of insulating material to be added may be taken as the difference between the required cover or effective thickness specified in this Section and the actual cover or effective thickness, whichever governs, multiplied by —

- (a) 0.75, for materials specified in Clauses 5.10.1.2 (a) and (b); or
- (b) an appropriate factor for materials specified in Clause 5.10.1.2(c), where the factor is derived from tests in which the difference calculated above lies within the range of insulation thickness tested;
- (c) and the thickness thus calculated rounded to the nearest 5 mm above.

5.10.1.4 *Reinforcement in sprayed or trowelled insulating materials*

Where the thickness of sprayed or trowelled insulating materials exceeds 10 mm, it shall be reinforced to prevent detachment during exposure to fire.

5.10.2 **Increase of insulation period of slabs by application of toppings**

The fire-resistance period for insulation of a slab may be increased by incorporating an integral or a separately applied topping of thickness given by the following equation:

$$t_{\text{nom}} = kt_d + 10$$

where

t_{nom} = nominal thickness of topping to be applied

k = 1.0 for a topping of plain concrete

= 0.8 for a topping of concrete made from lightweight aggregate complying with AS 2758.1

= 0.6 for a topping of gypsum (including jointed gypsum block) having a wearing overlay

t_d = the difference between the actual effective thickness of the slab and the effective thickness specified in Table 5.5.1, for the required fire-resistance period

5.11 RECESSES FOR SERVICES IN WALLS

The effect of recesses for services, on the fire-resistance periods for structural adequacy, integrity and insulation of a wall, shall be ignored if the thickness of wall remaining under the bottom of the recess is not less than half the wall thickness and the total recessed area, within any 5 m² of wall face, is not more than 10 000 mm² on one or both faces of the wall.

If the above limits are exceeded, the wall thickness (t) used to determine fire-resistance periods shall be taken as the overall thickness less the depth of the deepest recess.

5.12 CHASES

5.12.1 **General**

In concrete members subject to fire, chases shall be kept to a minimum. The effect of chases on the fire-resistance periods of walls shall be taken into account in accordance with the provisions of Clauses 5.12.2 and 5.12.3. The effects of chases in other members shall be taken into account using rational methods of analysis.

5.12.2 Effect of chases on structural adequacy of walls

The effect of chases, on the fire-resistance period for structural adequacy of walls, shall be taken into account as follows:

- (a) For walls spanning one way, where —
 - (i) the chase direction is parallel to the span direction — ignored;
 - (ii) the chase direction is perpendicular to the span direction and of length not greater than four times the wall thickness or 0.4 times the overall length of the wall, whichever is greater — ignored; or
 - (iii) the chase is perpendicular to the span direction and of length greater than four times the wall thickness or 0.4 times the overall length of the wall— accounted for by using a slenderness ratio for the wall based on the reduced wall thickness.
- (b) For walls spanning two ways (panel action), where —
 - (i) there is either a vertical chase with a length not greater than half the wall height (H), or a horizontal chase with a length not greater than half the wall length (L)— ignored;
 - (ii) the length of a vertical chase is greater than half the wall height (H), or the length of a horizontal chase is greater than half the wall length (L)— accounted for by using a slenderness ratio for the wall based on the reduced wall thickness, or the chase may be regarded as an unsupported edge and the panel designed as two sub-panels.

5.12.3 Effect of chases on integrity and insulation of walls

The effect of chases, on the fire-resistance periods for integrity and insulation of walls, shall be taken into account as follows:

- (a) Where —
 - (i) the depth of the chase is not greater than 30 mm;
 - (ii) the cross-sectional area of the chase, on a plane perpendicular to the plane of the wall face and at right angles to the centre-line of the chase, is not greater than 1000 mm²; and
 - (iii) the total face area of chases within any 5 m² of wall face is not greater than 100 000 mm² on one or both wall faces,
 the effect shall be ignored.
- (b) For cases other than those in Item (a) above, the effects shall be taken into account in accordance with the normal rules for insulation and integrity of walls, except that slenderness ratios shall be based on the reduced wall thickness.

SECTION 6 DESIGN PROPERTIES OF MATERIALS

6.1 PROPERTIES OF CONCRETE

6.1.1 Strength

6.1.1.1 Characteristic compressive strength

The characteristic compressive strength of concrete at 28 days (f'_c) may be either —

- (a) taken as equal to the specified strength grade, provided that the appropriate curing is ensured and that the concrete complies with AS 1379; or
- (b) determined statistically from compressive strength tests carried out in accordance with AS 1012.9.

The characteristic compressive strengths of the standard strength grades are 20 MPa, 25 MPa, 32 MPa, 40 MPa, 50 MPa, and 65 MPa.

6.1.1.2 Characteristic flexural tensile strength

The characteristic flexural tensile strength of concrete (f'_{ct}) may be either —

- (a) taken as equal to $0.6\sqrt{f'_c}$ at 28 days and standard curing; or
- (b) determined statistically from flexural strength tests carried out in accordance with AS 1012.11.

6.1.1.3 Characteristic principal tensile strength

The characteristic principal tensile strength of concrete (f'_{ct}) may be either —

- (a) taken as equal to $0.4\sqrt{f'_c}$ at 28 days and standard curing; or
- (b) determined statistically from indirect tensile strength tests carried out in accordance with AS 1012.10.

6.1.2 Modulus of elasticity

The modulus of elasticity of concrete at the appropriate age (E_{ci}) may be either —

- (a) taken as equal to $(\rho)^{1.5} \times (0.043\sqrt{f_{cm}})$, in megapascals, consideration being given to the fact that this value has a range of $\pm 20\%$; or
- (b) determined by test in accordance with AS 1012.17.

6.1.3 Density

The density of concrete (ρ) may be either —

- (a) for normal-weight concrete, taken as not less than 2400 kg/m³; or
- (b) determined by test in accordance with either AS 1012.12.1 or AS 1012.12.2.

6.1.4 Stress-strain curves

A stress-strain curve for concrete may be either —

- (a) assumed to be of curvilinear form defined by recognized simplified equations; or
- (b) determined from suitable test data.

For design purposes, the shape of the curve shall be modified so that the maximum stress is $0.85 f'_c$.

6.1.5 Poisson's ratio

Poisson's ratio for concrete, ν , may be either —

- (a) taken as equal to 0.2; or
- (b) determined by test in accordance with AS 1012.17.

6.1.6 Coefficient of thermal expansion

The coefficient of thermal expansion of concrete may be either —

- (a) taken as equal to $10 \times 10^{-6}/^{\circ}\text{C}$, consideration being given to the fact that this value has a range of $\pm 20\%$; or
- (b) determined from suitable test data.

6.1.7 Shrinkage

6.1.7.1 Basic shrinkage strain

The basic shrinkage strain of concrete ($\varepsilon_{cs,b}$), may be:

- (a) Normal-class concrete —
 - (i) determined from measurements on similar local concrete; or
 - (ii) taken as equal to 850×10^{-6} .
- (b) Special-class concrete —
 - (i) determined from measurements on similar local concrete; or
 - (ii) determined by tests after eight weeks drying, in accordance with AS 1012.13.

6.1.7.2 Design shrinkage strain

The design shrinkage strain (ε_{cs}) shall be determined from the basic shrinkage strain ($\varepsilon_{cs,b}$) by any accepted mathematical model for shrinkage behaviour, calibrated such that $\varepsilon_{cs,b}$ is also predicted by the chosen model.

In the absence of more accurate methods, the design shrinkage strain at any time after commencement of drying shrinkage may be taken as —

$$k_1 \varepsilon_{cs,b}$$

where

k_1 is obtained from Figure 6.1.7.2

Based on a value of $\varepsilon_{cs,b}$ of 850×10^{-6} , this method gives the typical design shrinkage strains given in Table 6.1.7.2.

Consideration shall be given to the fact that ε_{cs} has a range of $\pm 40\%$.

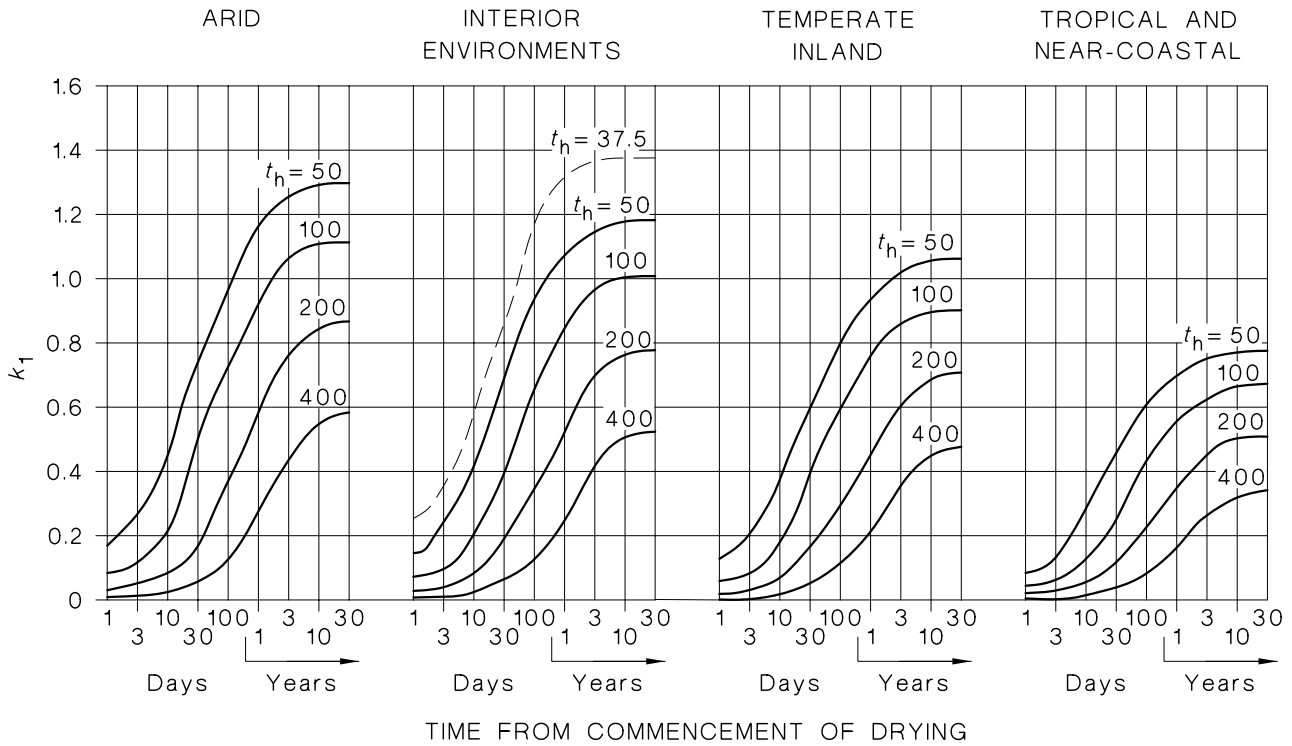

FIGURE 6.1.7.2 SHRINKAGE STRAIN COEFFICIENT (k_1) FOR VARIOUS ENVIRONMENTS

TABLE 6.1.7.2

TYPICAL DESIGN SHRINKAGE STRAINS AFTER 30 YEARS IN VARIOUS ENVIRONMENTS (FOR NORMAL-CLASS CONCRETE)

A1

Exposure environment	Final design shrinkage strain (ϵ_{cs}), 10^{-6}			
	Hypothetical thickness (t_h), mm			
	50	100	200	400
Arid	1 100	940	730	500
Interior environments	1 000	860	670	450
Temperate inland	900	760	590	410
Tropical and near-coastal	650	570	440	300

NOTE: For descriptions of exposure environments see Table 4.3 and Figure 4.3.

6.1.8 Creep

6.1.8.1 Basic creep factor

The basic creep factor of concrete ($\phi_{cc,b}$) is the ratio of ultimate creep strain to elastic strain for a specimen loaded at 28 days under a constant stress of $0.4f'_c$ and may be —

- (a) taken as the values given in Table 6.1.8.1; or
- (b) determined from measurements on similar local concrete; or
- (c) determined by tests in accordance with AS 1012.16.

TABLE 6.1.8.1
BASIC CREEP FACTOR

Characteristic strength (f'_c), MPa	20	25	32	40	≥ 50
Creep factor $\phi_{cc,b}$	5.2	4.2	3.4	2.5	2.0

6.1.8.2 Design creep factor

The design creep factor (ϕ_{cc}) for concrete shall be determined from the basic creep factor ($\phi_{cc,b}$) by any accepted mathematical model for creep behaviour, calibrated such that $\phi_{cc,b}$ is also predicted by the chosen model.

In the absence of more accurate methods, ϕ_{cc} at any time may be taken as —

$$k_2 k_3 \phi_{cc,b}$$

where k_2 and k_3 are obtained from Figure 6.1.8.2(A) and Figure 6.1.8.2(B) respectively.

Consideration shall be given to the fact that ϕ_{cc} has a range of approximately $\pm 30\%$. This range is likely to be exceeded if—

- the cement used in the concrete has a sulphate content, expressed as SO_3 by mass of cement in accordance with AS 2350.2, outside the range 2% to 3.5%; or
- the concrete member is subjected to prolonged periods of temperature in excess of $25^\circ C$; or
- the member is subject to sustained stress levels in excess of $0.5f'_c$.

Based on a value of 2.5 for $\phi_{cc,b}$, this method gives the typical design creep factors given in Table 6.1.8.2.

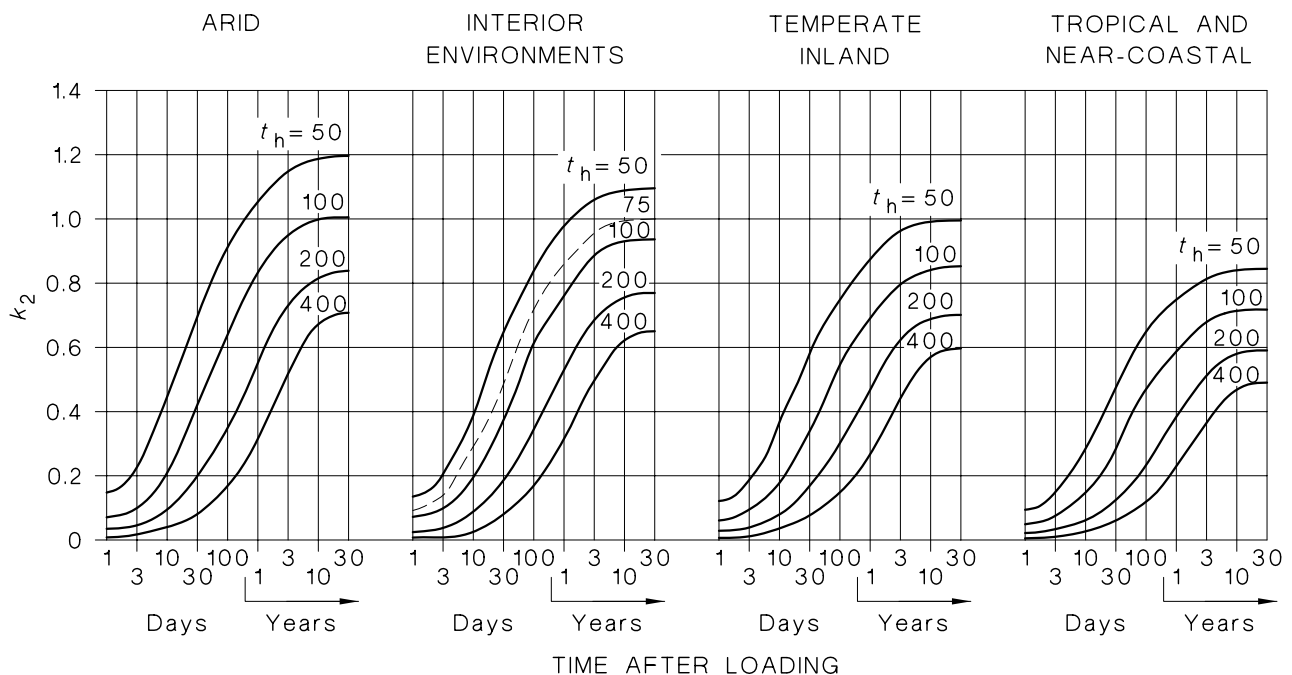

A1

FIGURE 6.1.8.2 (A) CREEP FACTOR COEFFICIENT (k_2) FOR VARIOUS ENVIRONMENTS

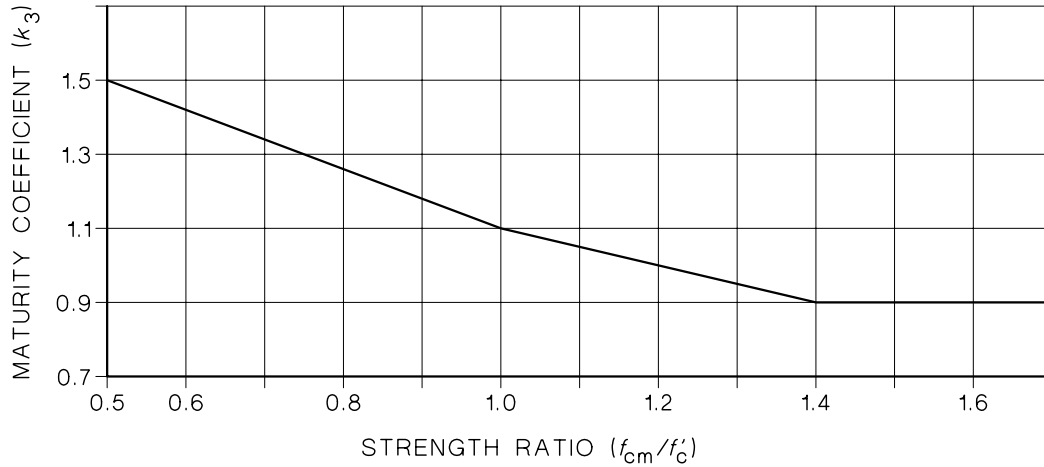

A1

FIGURE 6.1.8.2(B) MATURITY COEFFICIENT (k_3)

TABLE 6.1.8.2
TYPICAL DESIGN CREEP FACTOR AFTER 30 YEARS IN VARIOUS
ENVIRONMENTS FOR $\phi_{cc,b} = 2.5$

Exposure environment	Concrete age at loading	Design creep factor (ϕ_{cc})			
		Hypothetical thickness (t_h), mm			
	days	50	100	200	400
Arid	0 to 7	3.9	3.3	2.7	2.3
	8 to 28	3.0	2.5	2.1	1.8
	> 28	2.7	2.3	1.9	1.6
Interior environment	0 to 7	3.5	3.1	2.5	2.1
	8 to 28	2.7	2.3	1.9	1.6
	> 28	2.5	2.1	1.7	1.5
Temperate inland	0 to 7	3.2	2.8	2.3	1.9
	8 to 28	2.5	2.1	1.8	1.5
	> 28	2.2	1.9	1.6	1.3
Tropical and near-coastal	0 to 7	2.7	2.3	1.9	1.6
	8 to 28	2.1	1.8	1.5	1.3
	> 28	1.9	1.6	1.4	1.1

NOTE: For descriptions of exposure environments, see Table 4.3, and Figure 4.3.

6.2 PROPERTIES OF REINFORCEMENT

6.2.1 Strength and ductility

The yield strength of reinforcement (f_{sy}) shall be taken as not greater than the value specified in Table 6.2.1 for the appropriate type of reinforcement (see also Clause 19.2.1.1).

The ductility of the reinforcement shall be characterized by its uniform strain (ϵ_{su}) and tensile-to-yield stress ratio and designated as low (L) or normal (N) as given in Table 6.2.1. Values of these parameters for each ductility class shall comply with AS/NZS 4671.

Reinforcement types complying with AS 1302 may be considered to be Class N without any additional testing requirements. Testing is required for reinforcement types complying with AS 1303 and AS 1304 to demonstrate that they satisfy the requirements for Class L steels specified in AS/NZS 4671.

TABLE 6.2.1
STRENGTH AND DUCTILITY OF REINFORCEMENT

Reinforcement		Yield strength (f_{sy}) MPa	Ductility Class
Type	Designation grade		
Bar—			
Plain to AS 1302	250R (fitments only)	250	N
Deformed to AS 1302	250S	250	N
Deformed to AS 1302	400Y	400	N
Wire, plain or deformed to AS 1303	450W (fitments only)	450	L
Welded wire mesh, plain or deformed to AS 1304	450F	450	L
Bar deformed to AS/NZS 4671	D500L (fitments only)	500	L
	D500N	500	N
Welded wire mesh, plain, deformed and indented to AS/NZS 4671	D500L	500	L
	D500N	500	N

NOTE: Reference should be made to AS/NZS 4671 for explanation to designations applying to 500 MPa steels.

6.2.2 Modulus of elasticity

The modulus of elasticity of reinforcement (E_s) for all stress values not greater than the yield strength (f_{sy}) may be either —

- taken as equal to 200×10^3 MPa; or
- determined by test.

6.2.3 Stress-strain curves

A stress-strain curve for reinforcement may be either —

- assumed to be of a form defined by recognized simplified equations; or
- determined from suitable test data.

6.2.4 Coefficient of thermal expansion

The coefficient of thermal expansion of reinforcement may be either —

- taken as equal to $12 \times 10^{-6}/^{\circ}\text{C}$; or
- determined from suitable test data.

6.3 PROPERTIES OF TENDONS

6.3.1 Strength

- The tensile strength of tendons (f_p) shall be taken as the minimum tensile strength specified in Table 6.3.1.
- The yield strength of tendons (f_{py}) may either be taken as —
 - for wire used in the as-drawn condition $0.75f_p$;
 - for stress-relieved wire $0.85f_p$;
 - for all grades of strand and bar tendons $0.85f_p$; or
 - determined by test.

TABLE 6.3.1
TENSILE STRENGTH OF COMMONLY USED WIRE STRAND AND BAR

Material type and Standard	Nominal diameter	Area mm ²	Minimum breaking load	Minimum tensile strength (f_p)
	mm		kN	MPa
Wire, AS 1310	5	19.6	30.4	1 550
	5	19.6	33.3	1 700
	7	38.5	65.5	1 700
7-wire super strand, AS 1311	9.3	54.7	102	1 860
	12.7	100	184	1 840
	15.2	143	250	1 750
7-wire regular strand, AS 1311	12.7	94.3	165	1 750
Bars, AS 1313 (Super grade only)	23	415	450	1 080
	29	660	710	1 080
	32	804	870	1 080
	38	1 140	1 230	1 080

6.3.2 Modulus of elasticity

The modulus of elasticity of tendons (E_p) may be either —

- (a) taken as equal to —
 - (i) for stress-relieved wire to AS 1310 200×10^3 MPa;
 - (ii) for stress-relieved steel strand to AS 1311 195×10^3 MPa;
 - (iii) for cold worked high tensile alloy steel bars to AS 1313 170×10^3 MPa; or
- (b) determined by test.

Consideration should be given to the fact that the modulus of elasticity of tendons may vary by $\pm 5\%$ and will vary more when a number of tendons are combined into a single cable.

6.3.3 Stress-strain curves

A stress-strain curve for tendons may be determined from appropriate test data.

6.3.4 Relaxation of tendons

6.3.4.1 General

This Clause applies to the relaxation, at any age and stress level, of low-relaxation wire, low-relaxation strand, and alloy-steel bars.

6.3.4.2 Basic relaxation

The basic relaxation (R_b) of a tendon after one thousand hours at 20°C and $0.7f_p$ may be either —

- (a) taken as equal to, for Australian manufactured materials —
 - (i) low-relaxation wire 1%;
 - (ii) low-relaxation strand 2%;
 - (iii) alloy-steel bars 3%; or
- (b) determined in accordance with AS 1310, AS 1311, or AS 1313 as appropriate.

6.3.4.3 Design relaxation

The design relaxation of a tendon (R) shall be determined from —

$$R = k_4 k_5 k_6 R_b$$

where

k_4 = a coefficient dependent on the duration of the prestressing force
 = $\log [5.4(j)^{1/6}]$

j = the time after prestressing, in days

k_5 = a coefficient, dependent on the stress in the tendon as a proportion of f_p , determined from Figure 6.3.4.3

k_6 = a function, dependent on the average annual temperature (T) in degrees Celsius, taken as $T/20$ but not less than 1.0

When determining the design relaxation, consideration shall be given to the effects of curing at elevated temperatures, if applicable.

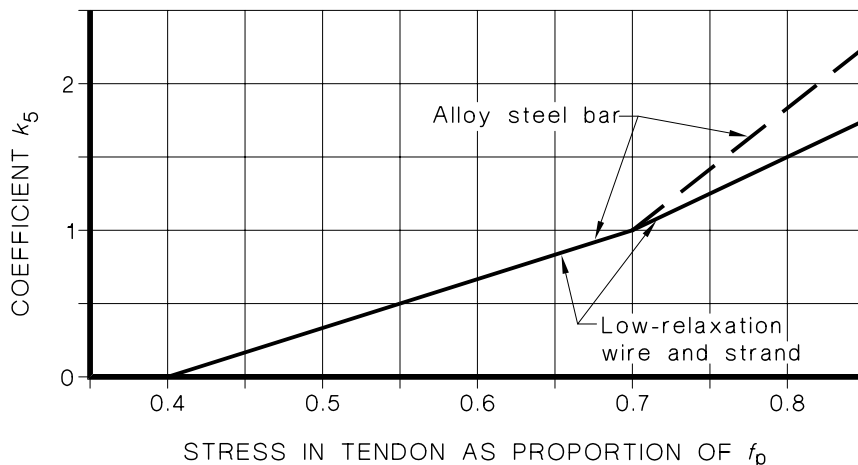

FIGURE 6.3.4.3 COEFFICIENT k_5

6.4 LOSS OF PRESTRESS IN TENDONS

6.4.1 General

The loss of prestress in tendons at any given time shall be taken to be the sum of the immediate loss of prestress and the time-dependent loss of prestress, calculated in accordance with Clauses 6.4.2 and 6.4.3 respectively.

For structures designed to operate above 40°C, special calculations based on appropriate test data shall be made.

6.4.2 Immediate loss of prestress

6.4.2.1 General

The immediate loss of prestress shall be estimated by adding the calculated losses of prestress due to elastic deformation of concrete, friction, anchoring and other immediate losses as may be applicable.

6.4.2.2 *Loss of prestress due to elastic deformation of concrete*

Calculation of the immediate loss of prestress due to elastic deformation of the concrete at transfer shall be based on the value of modulus of elasticity of the concrete at that age.

6.4.2.3 *Loss of prestress due to friction*

The stress variation along the design profile of a tendon due to friction in the jack, the anchorage and the duct shall be assessed as follows in order to obtain an estimate of the prestressing forces at the critical sections considered in the design.

The extension of the tendon shall be calculated allowing for the variation in tension along its length.

- (a) *Friction in the jack and anchorage* The loss of prestress due to friction in the jack and anchorage shall be determined for the type of jack and anchorage system to be used.
- (b) *Friction along the tendon* Friction loss shall be calculated from an analysis of the forces exerted by the tendon on the duct. In the absence of more detailed calculations the stress in the tendon (σ_{pa}) at a distance 'a', measured from the jacking end, may be taken as —

$$\sigma_{pa} = \sigma_{pj} e^{-\mu(\alpha_{tot} + \beta_p L_{pa})}$$

where

σ_{pi} = the stress in the tendon at the jacking end

e = the base of Napierian logarithms

μ = the friction curvature coefficient for different conditions which, in the absence of specific data and when all tendons in contact in the one duct are stressed simultaneously, may be taken as—

- (i) for greased-and-wrapped coating 0.15;
- (ii) for bright and zinc-coated metal sheathing 0.15 to 0.20;
- (iii) for bright and zinc-coated flat metal ducts 0.20

α_{tot} = the sum in radians of the absolute values of successive angular deviations of the prestressing tendon over the length (L_{pa})

β_p = an estimate, in radians per metre (rad/m), of the angular deviation due to wobble effects, which as a first approximation may be taken as—

- (i) for sheathing containing tendons other than bars and having an internal diameter —
 - ≤ 50 mm: 0.024 to 0.016 rad/m
 - > 50 mm but ≤ 90 mm: 0.016 to 0.012 rad/m
 - > 90 mm but ≤ 140 mm: 0.012 to 0.008 rad/m
- (ii) for flat metal ducts containing tendons other than bars: 0.024 rad/m to 0.016 rad/m;
- (iii) for sheathing containing bars and having an internal diameter of 50 mm or less: 0.016 rad/m to 0.008 rad/m;
- (iv) for bars of any diameter in a greased-and-wrapped coating: 0.008 rad/m

L_{pa} = the length of the tendon from the jacking end to a point at a distance 'a' from that end

The magnitude of the friction due to duct curvature and wobble used in the design shall be verified during the stressing operation.

6.4.2.4 *Loss of prestress during anchoring*

In a post-tensioned member, allowance shall be made for loss of prestress when the prestressing force is transferred from the tensioning equipment to the anchorage. This allowance shall be checked on the site and any adjustment correspondingly required shall be made.

6.4.2.5 *Loss of prestress due to other considerations*

Where applicable, loss of prestress, due to the following, shall be taken into account in design:

- (a) Deformation of the forms for precast members.
- (b) Differences in temperature between stressed tendons and the actual stressed structures during heat treatment of the concrete.
- (c) Changes in temperature between the time of stressing the tendons and the time of casting concrete.
- (d) Deformations in the construction joints of precast structures assembled in sections.
- (e) Relaxation of the tendon prior to transfer.

6.4.3 Time-dependent losses of prestress

6.4.3.1 *General*

The total time-dependent loss of prestress shall be estimated by adding the calculated losses of prestress due to shrinkage of the concrete, creep of the concrete, tendon relaxation, and other considerations as may be applicable.

6.4.3.2 *Loss of prestress due to shrinkage of the concrete*

The loss of stress in the tendon due to shrinkage of the concrete shall be taken as $E_p \varepsilon_{cs}$, modified to allow for the effects of reinforcement, where ε_{cs} is determined in accordance with Clause 6.1.7.2.

Where reinforcement is distributed throughout the member so that its effect on shrinkage is mainly axial, the loss of prestress in the tendons may be taken as $(E_p \varepsilon_{cs})$ divided by $(1 + 15A_s/A_g)$.

6.4.3.3 *Loss of prestress due to creep of the concrete*

The loss of prestress due to creep of the concrete shall be calculated from an analysis of the creep strains in the concrete. In the absence of more detailed calculations and provided that the sustained stress in the concrete at the level of the tendons at no time exceeds $0.5 f'_c$, the loss of stress in the tendon due to creep of the concrete may be taken as $E_p \varepsilon_{cc}$, in which ε_{cc} is given by —

$$\varepsilon_{cc} = \phi_{cc} (\sigma_{ci} / E_c)$$

where

- ϕ_{cc} = the design creep factor, calculated in accordance with Clause 6.1.8.2
- σ_{ci} = the sustained stress in the concrete at the level of the centroid of the tendons, calculated using the initial prestressing force prior to any time-dependent losses and the sustained portions of all the service loads given in Clause 3.4

6.4.3.4 *Loss of prestress due to tendon relaxation*

The loss of stress in a tendon due to relaxation of the tendon in the member shall be determined by modifying the percentage loss of stress due to the design relaxation of the tendon (R) to take into account the effects of shrinkage and creep.

In the absence of more detailed calculations, the percentage loss of stress in the tendon in the member may be taken as—

$$R \left(1 - \frac{\text{the loss of stress due to creep and shrinkage}}{\sigma_{pi}} \right)$$

where

σ_{pi} = the stress in the tendon immediately after transfer

6.4.3.5 *Loss of prestress due to other considerations*

Account shall be taken, if applicable, of—

- (a) losses due to deformations in the joints of precast structures assembled in sections;
and
- (b) losses due to the effects of any increase in creep caused by frequently repeated loads.

SECTION 7 METHODS OF STRUCTURAL ANALYSIS

7.1 GENERAL

7.1.1 Methods of analysis

For the purpose of complying with the requirements for stability, strength and serviceability specified in Section 2, the action effects in a structure and its component members shall be determined by one of the following methods:

- (a) For reinforced continuous beams or one-way slabs, the simplified method given in Clause 7.2.
- (b) For reinforced two-way slabs supported by walls or beams on all four sides, the simplified method given in Clause 7.3.
- (c) For reinforced two-way slab systems having multiple spans, the simplified method given in Clause 7.4.
- (d) For reinforced or prestressed framed structures incorporating two-way slab systems, the idealized frame method given in Clause 7.5.
- (e) For reinforced or prestressed structures—
 - (i) static analysis for determinate structures;
 - (ii) linear elastic analysis, in accordance with Clause 7.6;
 - (iii) an elastic analysis incorporating secondary bending moments due to lateral joint displacement, in accordance with Clause 7.7; or
 - (iv) rigorous structural analysis, in accordance with Clause 7.8.
- (f) For slabs and frames, plastic methods of analysis, in accordance with Clause 7.9 or 7.10.
- (g) For isolated footings and pile-caps and, where applicable, for combined footings, mats and pile-caps—
 - (i) where flexural action may be assumed, the methods given in this Section; or
 - (ii) where flexural action cannot be assumed, the methods given in Section 12.
- (h) For non-flexural members, the methods given in Section 12.
- (i) For any structure, member, or assembly of members, structural model tests designed and evaluated in accordance with the principles of mechanics.

7.1.2 Definitions

For the purpose of this Section, the following definitions apply:

7.1.2.1 Column strip

That portion of the design strip extending transversely from the centre-line of the supports—

- (a) for an interior column strip, one-quarter of the distance to the centre-line of each adjacent and parallel row of supports; or
- (b) for an edge column strip, to the edge of the slab and one-quarter of the distance to the centre line of the next interior and parallel row of supports,

but of total width not greater than $L/2$, as shown in Figure 7.1.2(A).

7.1.2.2 *Design strip*

That part of a two-way slab system, which is supported, in the direction of bending being considered, by a single row of supports and which in each span extends transversely from the centre-line of the supports —

- (a) for an interior design strip, halfway to the centre-line of each adjacent and parallel row of supports; or
- (b) for an edge design strip, to the edge of the slab and halfway to the centre-line of the next interior and parallel row of supports (see Figure 7.1.2(A)).

7.1.2.3 *Middle strip*

The portion of the slab between two column strips or between a column strip and a parallel supporting wall (see Figure 7.1.2(A)).

7.1.2.4 *Span support*

The length of a support in the direction of the span (a_s) taken as —

- (a) for beams or for flat slabs without either drop panels or column capitals, the distance from the centre-line of the support to the face of the support; or
- (b) for flat slabs with drop panels or column capitals or both, the distance from the centre-line of the support to the intersection with the plane of the slab soffit of the longest line, inclined at an angle of 45° to the centre-line of the support, which lies entirely within the surfaces of the slab and the support,

as shown in Figure 7.1.2(B).

For the purpose of Item (b), circular or polygonal columns may be regarded as square columns with the same cross-sectional area.

7.1.2.5 *Transverse width*

The width of the design strip (L_t) measured perpendicular to the direction of bending being considered (see Figure 7.1.2(A)).

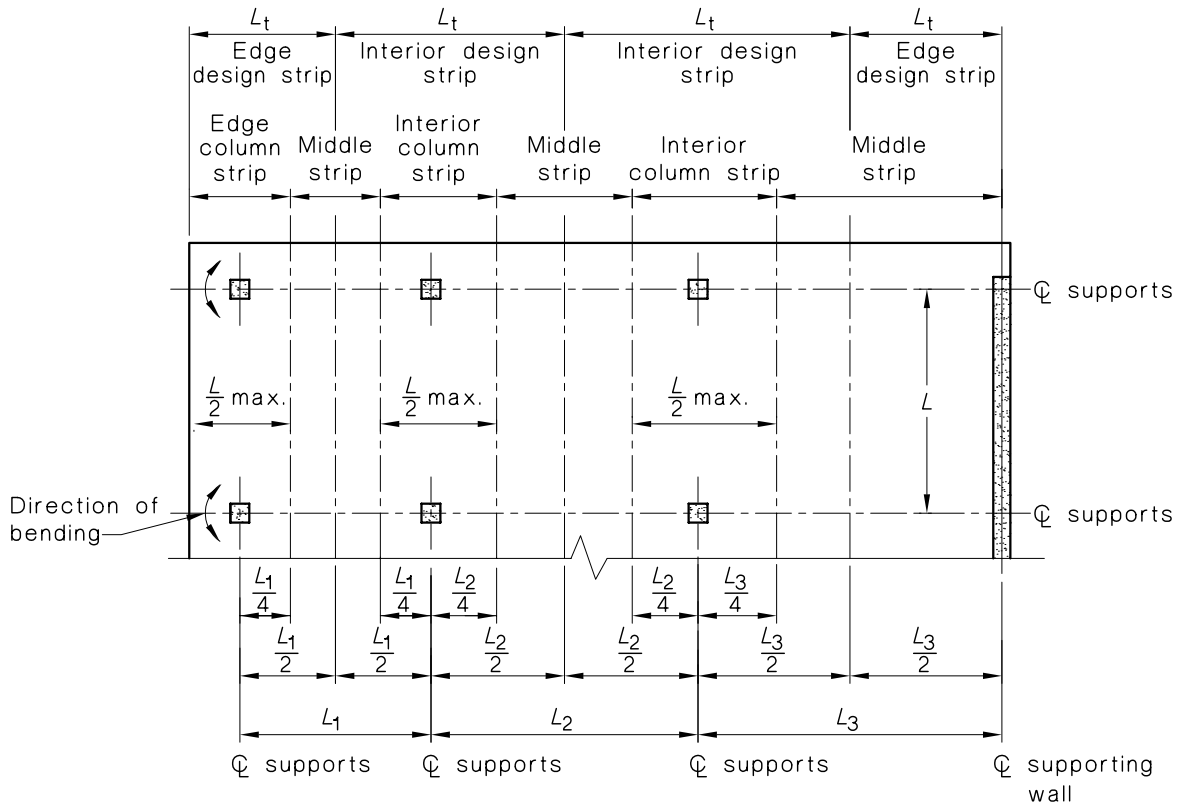

FIGURE 7.1.2(A) WIDTHS OF STRIPS FOR TWO-WAY SLAB SYSTEMS

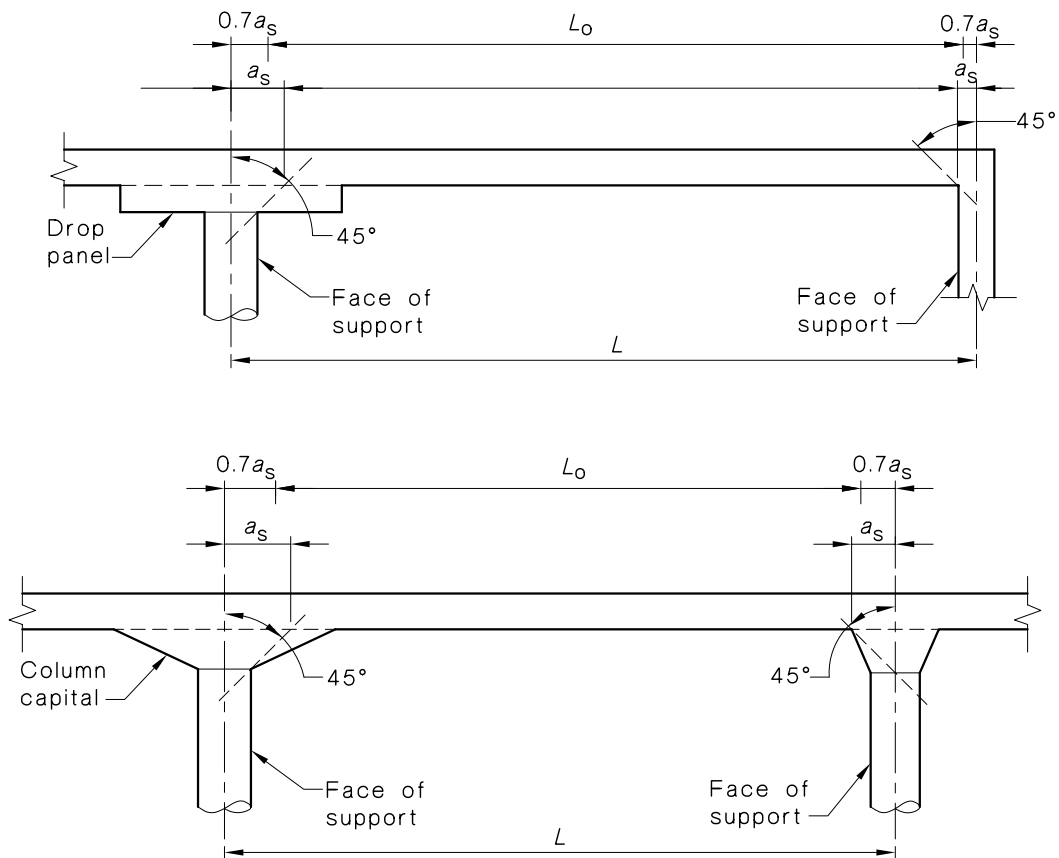

FIGURE 7.1.2(B) SPAN SUPPORT AND SPAN LENGTHS FOR FLAT SLABS

7.2 SIMPLIFIED METHOD FOR REINFORCED CONTINUOUS BEAMS AND ONE-WAY SLABS

7.2.1 Application

Clauses 7.2.2 to 7.2.4 may be used for the calculation of design bending moments and shear forces for strength in continuous beams and one-way slabs of reinforced concrete construction, provided that —

- (a) the ratio of the longer to the shorter length of any two adjacent spans does not exceed 1.2;
- (b) the loads are essentially uniformly distributed;
- (c) the live load (*q*) does not exceed twice the dead load (*g*);
- (d) members are of uniform cross-section;
- AI | (e) the reinforcement is arranged in accordance with the requirements of Clause 8.1.8.6 or Clause 9.1.3.2, as applicable; and
- (f) bending moments at supports are caused only by the action of loads applied to the beam or slab.

7.2.2 Negative design moment

The negative design moment at the critical section, taken for the purpose of this Clause at the face of the support, shall be as follows:

- (a) At the first interior support:
 - (i) Two spans only $F_d L_n^2 / 9$.
 - (ii) More than two spans..... $F_d L_n^2 / 10$.
- (b) At other interior supports..... $F_d L_n^2 / 11$.
- (c) At interior faces of exterior supports for members built integrally with their supports:
 - (i) For beams where the support is a column $F_d L_n^2 / 16$.
 - (ii) For slabs and beams where the support is a beam $F_d L_n^2 / 24$.

7.2.3 Positive design moment

The positive design moment shall be taken as follows:

- (a) In an end span $F_d L_n^2 / 11$.
- (b) In interior spans..... $F_d L_n^2 / 16$.

7.2.4 Transverse design shear force

The transverse design shear force in a member shall be taken as follows:

- (a) In an end span:
 - (i) At the face of the interior support $1.15 F_d L_n / 2$.
 - (ii) At mid-span $F_d L_n / 7$.
 - (iii) At the face of the end support $F_d L_n / 2$.
- (b) In interior spans:
 - (i) At the face of supports..... $F_d L_n / 2$.
 - (ii) At mid-span $F_d L_n / 8$.

Accessed by CARDNO MBK QLD PTY LTD on 31 Jan 2005

7.3 SIMPLIFIED METHOD FOR REINFORCED TWO-WAY SLABS SUPPORTED ON FOUR SIDES

7.3.1 Application

The design bending moments and shear forces for strength in reinforced two-way simply supported or continuous rectangular slabs, which are supported by walls or beams on four sides, may be determined from Clauses 7.3.2 to 7.3.4 provided that—

- (a) the loads are essentially uniformly distributed;
- (b) the reinforcement is arranged in accordance with the requirements of Clause 9.1.3.3; and
- (c) bending moments at supports are caused only by the action of loads applied to the beam or slab.

7.3.2 Design bending moments

The design bending moments in a slab shall be determined as follows:

- (a) The positive design bending moments at mid-span, M_x^* and M_y^* , on strips of unit width spanning, L_x and L_y , respectively shall be calculated from the following equations:

$$M_x^* = \beta_x F_d L_x^2$$

$$M_y^* = \beta_y F_d L_y^2$$

where F_d is the uniformly distributed design load per unit area factored for strength and β_x and β_y are given in Table 7.3.2.

The moments, so calculated, shall apply over a central region of the slab equal to three-quarters of L_x and L_y respectively. Outside of this region, the requirement for strength shall be deemed to be complied with by the minimum strength requirement of Clause 9.1.1.

- (b) The negative design bending moments at a continuous slab edge shall be taken as 1.33 times the midspan values in the direction considered.

If the negative moment on one side of a common support is different from that on the other side, the unbalanced moment may be redistributed.

- (c) The negative design bending moment at a discontinuous edge, where there is a likelihood of restraint, may be taken as half the midspan value in the direction considered.

7.3.3 Torsional moment at exterior corners

The torsional moment at the exterior corners of a slab shall be deemed to be resisted by complying with the requirements of Clause 9.1.3.3.

7.3.4 Load allocation

For calculating shear forces in the slab or the forces applied to the supporting walls or beams in the absence of more accurate calculations, it may be assumed that the uniformly distributed load on the slab is allocated to the supporting beams or walls as shown in Figure 7.3.4.

TABLE 7.3.2
BENDING MOMENT COEFFICIENTS FOR RECTANGULAR SLABS SUPPORTED
ON FOUR SIDES

Edge condition	Short span coefficients (β_x)								Long span coefficients (β_y) for all values of L_y/L_x
	Values of L_y/L_x								
	1.0	1.1	1.2	1.3	1.4	1.5	1.75	≥ 2.0	
1 Four edges continuous	0.024	0.028	0.032	0.035	0.037	0.040	0.044	0.048	0.024
2 One short edge discontinuous	0.028	0.032	0.036	0.038	0.041	0.043	0.047	0.050	0.028
3 One long edge discontinuous	0.028	0.035	0.041	0.046	0.050	0.054	0.061	0.066	0.028
4 Two short edges discontinuous	0.034	0.038	0.040	0.043	0.045	0.047	0.050	0.053	0.034
5 Two long edges discontinuous	0.034	0.046	0.056	0.065	0.072	0.078	0.091	0.100	0.034
6 Two adjacent edges discontinuous	0.035	0.041	0.046	0.051	0.055	0.058	0.065	0.070	0.035
7 Three edges discontinuous (one long edge continuous)	0.043	0.049	0.053	0.057	0.061	0.064	0.069	0.074	0.043
8 Three edges discontinuous (one short edge continuous)	0.043	0.054	0.064	0.072	0.078	0.084	0.096	0.105	0.043
9 Four edges discontinuous	0.056	0.066	0.074	0.081	0.087	0.093	0.103	0.111	0.056

7.4 SIMPLIFIED METHOD FOR REINFORCED TWO-WAY SLAB SYSTEMS HAVING MULTIPLE SPANS

7.4.1 Application

For multiple-span reinforced two-way slab systems; including solid slabs with or without drop panels, slabs incorporating ribs in two directions (waffle slabs) and beam-and-slab systems including thickened-slab bands, bending moments and shear forces in both directions may be determined in accordance with this Clause provided that the following requirements are met:

- (a) There are at least two continuous spans in each direction.
- (b) The support grid is rectangular, except that individual supports may be offset up to a maximum of 10% of the span in the direction of the offset.
- (c) In any portion of the slab enclosed by the centre-lines of its supporting members, the ratio of the longer span to the shorter span is not greater than 2.0.
- (d) In the design strips in each direction, successive span lengths do not differ by more than one third of the longer span and in no case is an end-span longer than the adjacent interior span.
- (e) Lateral forces on the structure are resisted by shear walls or braced frames.
- (f) Vertical loads are essentially uniformly distributed.
- (g) The live load (q) does not exceed twice the dead load (g).
- (h) The reinforcement is arranged in accordance with Clause 9.1.3.4 or Clause 8.1.8.6, as applicable.

A1

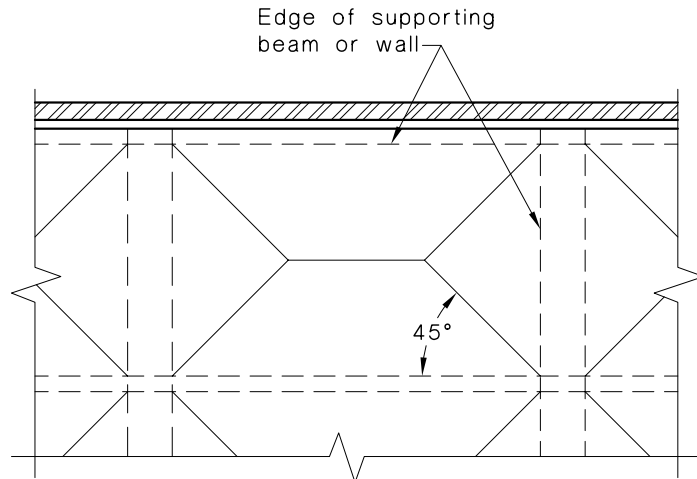

FIGURE 7.3.4 ALLOCATION OF LOAD

7.4.2 Total static moment for a span

The total static moment (M_o), for a span of the design strip shall be taken as not less than —

$$M_o = \frac{F_d L_t L_o^2}{8}$$

where

F_d = the design load per unit area on the slab

L_t = the width of the design strip

L_o = L minus 0.7 times the sum of the values of a_s at each end of the span (see Figure 7.1.2(B))

7.4.3 Design moments

The design moments in a span shall be determined by multiplying the total static moment (M_o) by the relevant factor given in Tables 7.4.3(A) and 7.4.3(B).

These design moments may be modified by up to 10% provided that the total static moment (M_o) for the span in the direction considered is not reduced.

The section under negative moment shall be designed to resist the larger of the two interior negative design moments determined for the spans framing into a common support, unless an analysis is made to distribute the unbalanced moment in accordance with the stiffness of the adjoining members.

TABLE 7.4.3(A)
DESIGN MOMENT FACTORS FOR AN END SPAN

Type of slab system and edge rotation restraint	Exterior negative moment factor	Positive moment factor	Interior negative moment factor
Flat slabs with exterior edge unrestrained	0.0	0.60	0.80
Flat slabs with exterior edge restrained by columns only	0.25	0.50	0.75
Flat slabs with exterior edge restrained by spandrel beams and columns	0.30	0.50	0.70
Flat slabs with exterior edge fully restrained	0.65	0.35	0.65
Beam-and-slab construction	0.15	0.55	0.75

TABLE 7.4.3(B)
DESIGN MOMENT FACTORS FOR AN INTERIOR SPAN

Type of slab system	Negative moment factor	Positive moment factor
All types	0.65	0.35

7.4.4 Transverse distribution of the design bending moment

The design negative and positive bending moments shall be distributed to the column strip and middle strip in accordance with Clause 7.5.5.

7.4.5 Moment transfer for shear in flat slabs

For the purpose of shear design, the bending moment, transferred from the slab to the support (M_v^*) shall be taken as the unbalanced bending moment at that support.

At an interior support, M_v^* shall be taken as not less than —

$$0.06 \left[(1.25g + 0.75q)L_t(L_o)^2 - 1.25g L_t(L_o')^2 \right]$$

where

L_o' = is the smaller value of L_o for the adjoining spans

At an exterior support, the actual moment shall be taken.

7.4.6 Shear forces in beam-and-slab construction

In beam-and-slab construction, the shear forces in the supporting beams may be determined by using the allocation of load given in Clause 7.3.4.

7.4.7 Openings in slabs

Only openings that comply with the requirements of Clauses 7.5.7(a) and 7.5.7(b) shall be permitted in slabs.

7.5 IDEALIZED FRAME METHOD FOR STRUCTURES INCORPORATING TWO-WAY SLAB SYSTEMS

7.5.1 Application

This Clause applies to the analysis of reinforced and prestressed framed structures incorporating two-way slab systems having multiple spans including—

- (a) solid slabs with or without drop panels;
- (b) slabs incorporating ribs in two directions, including waffle-slabs;
- (c) slabs having recessed soffits, if the portion of reduced thickness lies entirely within both middle strips;
- (d) slabs having openings complying with the requirements of Clause 7.5.7; and
- (e) beam-and-slab systems, including thickened slab bands.

7.5.2 The idealized frame

The idealized frame shall be one of a series of approximately parallel frames running longitudinally through the building, and a second series running transversely through the building.

Each idealized frame shall consist of the structure formed by the full height of a row of vertical supports, including footings and the design strips at each floor level supported by them.

7.5.3 Arrangement of vertical load for buildings

For building structures, the arrangement of vertical loads considered in the analysis shall consist of at least the following:

- (a) Where the live loading pattern is fixed, the factored live load.
- (b) Where the live load (Q) is variable but is not greater than three-quarters of the dead load (G), factored live load on all spans.
- (c) Where the live load (Q) is variable and exceeds three-quarters of the dead load (G) for the floor under consideration—
 - (i) three-quarters of the factored live load on alternate spans;
 - (ii) three-quarters of the factored live load on two adjacent spans; and
 - (iii) factored live load on all spans.
- (d) The factored dead load, but patterned variations of factored dead loads need not be considered.

7.5.4 Calculation of action effects in the idealized frame

Each idealized frame shall be analysed in its entirety except that, for vertical loads on the frame it shall be permissible to analyse one floor at a time in accordance with Clause 7.6.2.

The bending moments, shear forces and axial forces in the idealized frame shall be calculated in accordance with the requirements for the linear elastic analysis of frames as specified in Clause 7.6 except that Clause 7.6.4 shall not apply.

Any change in length of columns and slabs due to axial force and any deflection due to shear force may be neglected.

The effective width of the idealized frame to be used in the determination of bending moments, varies depending on span length and column size and may be different for vertical and lateral forces. In the absence of more accurate calculations, the stiffness of horizontal flexural members at each floor level for a vertical load analysis may be based on a width —

- (a) for flat slabs, equal to the width of the design strip, L_t ; or
- (b) for T-beams and L-beams, calculated in accordance with Clause 8.8.2.

7.5.5 Distribution of bending moments between column and middle strips

In the idealized frame method each design strip shall be divided into column strips and middle strips.

The column strip shall be designed to resist the total negative or positive bending moment at the critical cross-sections multiplied by an appropriate factor within the ranges given in Table 7.5.5.

That part of the design strip bending moment not resisted by the column strip shall be proportionally assigned to the half-middle strips on either side of it.

Each middle strip shall be designed to resist the sum of the moments assigned to its two adjoining halves, except that a middle strip adjacent to and parallel with an edge supported by a wall shall be designed to resist twice the bending moment assigned to the adjoining half middle strip from the next interior design strip parallel to the wall.

TABLE 7.5.5
DISTRIBUTION OF BENDING MOMENTS TO THE
COLUMN STRIP

Bending moment under consideration	Column strip moment factor
Negative moment at an interior support	0.60 to 1.00
Negative moment at an exterior support	0.75 to 1.00
Positive moment at all spans	0.50 to 0.70

7.5.6 Torsional moments

Where moment is transferred to the column by torsional moment in the slab or spandrel beams, the slab or spandrel beams shall be designed in accordance with Clause 8.3 or Clause 9.2, as applicable.

In beam-and-slab construction, the spandrel beams shall be reinforced with at least the minimum torsional reinforcement required by Clause 8.3.7.

7.5.7 Openings in slabs

Slabs containing openings may be analysed in accordance with all of Clause 7.5 without the need for further calculation provided that the amount of reinforcement interrupted by the opening is distributed to each side of the opening and the plan dimensions of the opening are no larger than the following:

- (a) The width of each middle strip, in the area common to two middle strips.
- (b) One-quarter of the width of each strip, in the area common to a column strip and a middle strip.
- (c) One-eighth of the width of each column strip, in the area common to two column strips, provided that the reduced section is capable of transferring the moment and shear forces to the support. The slab shall also comply with the shear requirements of Clause 9.2.

7.6 LINEAR ELASTIC ANALYSIS

7.6.1 Application

Linear elastic analysis may be used for the purpose of determining the action effects in a structure for strength and serviceability design.

For a structure that can be represented as a framework of line members, the analysis shall comply with Clauses 7.6.2 to 7.6.11. For other structures, the analysis shall comply with the general principles of these Clauses, as appropriate.

7.6.2 General

In the analysis of multistorey buildings, in situ concrete floor slabs may be assumed to act as horizontal diaphragms that distribute lateral forces to the framework.

Where the construction involves prefabricated elements supporting in situ construction, consideration in the analysis shall be given to the proposed construction sequence and the degree of propping of the prefabricated elements during construction.

The framework shall be analysed in its entirety, except that the following simplifications may be used:

- (a) Regular building structures analysed as a series of parallel frames, the analysis being carried out in each of two directions at right angles.
- (b) For beam and slab moments due to vertical loading in a building structure, each level thereof together with the columns as they occur above and below analysed separately, the columns being assumed fixed at the ends remote from the level under consideration. The bending moment at a given support determined on the assumption that the floor is fixed at the support one span away provided that the floor continues beyond that point.
- (c) For column forces and moments due to vertical loading in a building structure, each level of columns together with the floors above and below, if any, analysed separately, the columns being assumed fixed against rotation and translation at their remote ends and the floors being assumed fixed at the adjacent supports.

7.6.3 Span length

The span length of flexural members shall be taken as the distance centre-to-centre of supports.

7.6.4 Arrangement of vertical live loads for buildings

For building structures, the arrangement of vertical live loads considered in the analysis shall consist of at least the following:

- (a) Where the live loading pattern is fixed—the factored live load.
- (b) Where the live load (Q) is variable and is not greater than three-quarters of the resultant load due to dead load (G) and prestress—the factored live load on all spans.
- (c) Where the live load (Q) is variable and exceeds three-quarters of the resultant load due to dead load (G) and prestress—
 - (i) the factored live load on alternate spans;
 - (ii) the factored live load on two adjacent spans; and
 - (iii) the factored live load on all spans.

7.6.5 Stiffness

7.6.5.1 General

In the calculation of deformations and action effects in a structure, for both the serviceability and strength limit states, an estimate of the stiffness of each member shall be based on either —

- (a) the dimensions of the uncracked (gross) cross-sections; or
- (b) other reasonable assumptions, which better represent conditions at the limit state being considered, provided they are applied consistently throughout the analysis.

The effect of haunching and other variations of cross-section along the axis of a member shall be considered and, where significant, taken into account in the determination of the member stiffness.

7.6.5.2 Relative stiffness

In the calculation of the relative stiffness of members for analysis, any reasonable assumption may be made. All such assumptions shall be applied consistently throughout the analysis.

The effect of haunching and variation of the cross-section along the axis of a member shall be considered and, where significant, taken into account in the determination of relative stiffness.

7.6.5.3 Member stiffness

The assumed stiffness of members shall be chosen to represent conditions at the limit state being analysed.

7.6.6 Deflections

The calculated deflections shall take into account the effects of cracking, tension stiffening, shrinkage, creep, and relaxation. Calculations in accordance with the requirements of Clauses 8.5 and 9.3 shall be deemed to satisfy this requirement. Where appropriate, consideration shall be given to deformation that may result due to deflection of the formwork or settlement of the supporting props during construction.

7.6.7 Secondary bending moments and shear resulting from prestress

The secondary bending moments and shears, and associated deformations that are produced in an indeterminate structure by prestressing, shall be taken into account in the design calculations for serviceability.

The secondary bending moments and shears may be determined by elastic analysis of the unloaded, uncracked structure for the effects of prestress.

In design calculations for strength, the secondary bending moments and shears shall be included with a load factor of 1.0 when the design moments and shears for the load combinations given in Clause 3.3.1 are calculated. For the special case of dead load plus prestress at transfer, the load factors given by Clause 3.3.1 shall apply.

7.6.8 Moment redistribution in reinforced concrete members for strength design

7.6.8.1 General requirements

In design calculations for strength of statically indeterminate reinforced concrete members, the elastically determined bending moments at any interior support may be reduced or increased by redistribution, provided an analysis is undertaken to show that there is adequate rotation capacity in critical moment regions to allow the assumed distribution of bending moments to be achieved.

The analysis shall take into account —

- (a) the stress-strain curve of the steel reinforcement as defined in Clause 6.2.3 assuming for analysis purposes that fracture of the reinforcement occurs at ε_{su} ;
- (b) static equilibrium of the structure after redistribution of the moments; and
- (c) the properties of the concrete as defined in Clause 6.1.

Special consideration shall be given to the detrimental effects that significant relative foundation movements can have on the strength of continuous beams and slabs incorporating Ductility Class L reinforcing steel (low ductility) as the main reinforcement.

7.6.8.2 *Simplified approach for Class N reinforcement*

The requirement of Clause 7.6.8.1 shall be deemed to be met provided the following requirements are satisfied:

- (a) All of the main reinforcement in the member is Ductility Class N.
- (b) The elastic bending moment distribution before redistribution is determined in accordance with Clause 7.6.5(a) assuming uncracked cross-sections.
- (c) The positive bending moment is adjusted to maintain equilibrium.
- (d) Where the neutral axis parameter (k_u) is less than or equal to 0.2 in all peak moment regions, the redistribution does not exceed 30%.
- (e) Where k_u exceeds 0.2 in one or more peak moment regions, but does not exceed 0.4, the redistribution does not exceed 75 $(0.4 - k_u)\%$.
- (f) Where k_u exceeds 0.4 in any peak moment region, no redistribution is made.

NOTES:

- 1 The values of k_u are calculated for cross-sections that have been designed on the basis of the redistributed moment diagram.
- 2 The amount of redistribution is measured by the percentage of the bending moment before redistribution.

7.6.8.3 *Approval for Class L reinforcement*

Where Ductility Class L reinforcement is used, moment redistribution shall not be permitted unless an analysis, as specified in Clause 7.6.8.1, is undertaken.

7.6.9 **Moment redistribution in prestressed concrete members for strength design**

In the design of continuous prestressed concrete members for strength, the resultant elastically determined negative moment at any intermediate support, including the secondary moment, may be reduced or increased in accordance with the requirements of Clause 7.6.8.

7.6.10 **Critical section for negative moments**

The critical section for maximum negative bending moment shall be taken at 0.7 times the span support (a_s) from the centre-line of the support.

7.6.11 **Minimum transverse shear**

Where the design is based on uniformly distributed live loads, in order to provide for live load on part of the span, the minimum live load shear force to be resisted by any section of the member shall be taken as not less than one quarter of the maximum live load shear force in the member.

7.7 ELASTIC ANALYSIS OF FRAMES INCORPORATING SECONDARY BENDING MOMENTS

7.7.1 Application

This Clause applies to the analysis of frames not restrained by bracing or shear walls, or both, for which the relative displacement at the ends of compression members is less than $L_u/250$ under the design loads for strength.

7.7.2 General

An elastic analysis incorporating secondary bending moments shall comply with the requirements of Clause 7.6 and the following:

- (a) The effect of lateral joint displacements shall be taken into account.
- (b) For strength design of a regular rectangular framed structure, the cross-sectional stiffness of the flexural members and columns may be taken as $0.4E_cI_f$ and $0.8E_cI_c$ respectively.
- (c) For very slender members the change in bending stiffness of a member due to axial compression shall be considered.

7.8 RIGOROUS STRUCTURAL ANALYSIS

7.8.1 General

A rigorous structural analysis shall take into account the relevant material properties, geometric effects, three-dimensional effects and interaction with the foundations as specified in Clauses 7.8.2 to 7.8.6.

7.8.2 Material properties

The influence of the following material properties shall be taken into account:

- (a) Non-linear relation between stress and strain in the concrete.
- (b) Creep and shrinkage of the concrete.
- (c) Concrete cracking.
- (d) Tension stiffening.
- (e) Non-linear behaviour of the steel.

7.8.3 Geometric effects

Equilibrium of the structure in the deformed condition shall be taken into account whenever deflections within the length of an axially loaded member, or relative end displacements significantly influence the magnitude and distribution of action effects in the structure.

7.8.4 Three-dimensional effects

The three-dimensional nature of the structure shall be taken into account in the interpretation of the results of the analysis and, if relevant, in the analysis itself.

7.8.5 Interaction with the foundations

Interaction with the foundations shall be taken into account in the analysis.

7.8.6 Construction sequence and propping

The effects of construction sequences and techniques, including temporary propping, shall be considered in the analysis.

7.9 PLASTIC METHODS OF ANALYSIS FOR SLABS

7.9.1 General

Plastic methods of analysis based on lower bound or yield line theory may be used for the analysis for strength of one-way and two-way slabs, provided Ductility Class N reinforcement is used throughout. The reinforcement shall be arranged with due regard to the serviceability requirements.

7.9.2 Lower bound method

The design bending moments obtained using lower bound theory shall satisfy the requirements of equilibrium and the boundary conditions applicable to the slab.

7.9.3 Yield line method

A yield line analysis for strength design of a slab shall satisfy the following requirements:

- (a) The design bending moments shall be obtained from calculations based on the need for a mechanism to form over the whole or part of the slab at collapse.
- (b) The mechanism that gives rise to the most severe design bending moments shall be used for the design of the slab.

7.10 PLASTIC METHODS OF ANALYSIS OF FRAMES

Plastic methods of analysis may be used for the strength design of frames and continuous beams provided that the structure can be shown to possess the moment-rotation capacities required, to achieve the plastic redistribution of moments implied in the analysis.

SECTION 8 BEAMS FOR STRENGTH AND SERVICEABILITY

8.1 STRENGTH OF BEAMS IN BENDING

8.1.1 General

The strength of a beam cross-section under bending shall be determined using Clauses 8.1.2 to 8.1.8, the material properties given in Section 6 and the beam properties given in Clause 8.8.

This Clause does not apply to non-flexural members covered by Section 12.

8.1.2 Basic principles

8.1.2.1 Combined bending and axial force

Calculations for strength of cross-sections in bending, or in bending combined with axial force, shall incorporate equilibrium and strain-compatibility considerations and be consistent with the following assumptions:

- (a) Plane sections normal to the axis remain plane after bending.
- (b) The concrete has no tensile strength.
- (c) The distribution of compressive stress is determined from a stress-strain relationship for the concrete in accordance with Clause 6.1.4 (see Note below).
- (d) The strain in compressive reinforcement does not exceed 0.003.

NOTE: If a curvilinear stress-strain relationship is used, Clause 6.1.4 places a limit on the value of the maximum concrete stress.

8.1.2.2 Rectangular stress block

Where the neutral axis lies within the cross-section and provided that the maximum strain in the extreme compression fibre of the concrete is taken as 0.003, Clause 8.1.2.1(c) shall be deemed to be satisfied by assuming that a uniform compressive stress of $0.85 f'_c$ acts on an area bounded by —

- (a) the edges of the cross-section; and
- (b) a line parallel to the neutral axis at the strength limit state under the loading concerned, and located at a distance $\gamma k_u d$ from the extreme compressive fibre where—

$$\gamma = [0.85 - 0.007 (f'_c - 28)] \text{ with the limits } 0.65 \text{ to } 0.85$$

NOTE: The modification given in Clause 6.1.4 is included in the rectangular stress block assumptions.

8.1.2.3 Dispersion angle of prestress

In the absence of a more exact calculation, the dispersion angle of the prestressing force from the anchorage shall be assumed to be 60° , i.e. 30° either side of the centre-line.

8.1.3 Design strength in bending

The design strength in bending of a section with the neutral axis parameter (k_u) not greater than 0.4 shall be taken as ϕM_{u0} .

In peak moment regions, sections with k_u greater than 0.4 should be avoided. Sections with k_u greater than 0.4 shall not be used, unless all the following requirements are met:

- (a) The structural analysis shall be carried out in accordance with Clauses 7.6 to 7.8.

- (b) Compression reinforcement of at least 0.01 times the area of concrete in compression shall be provided.
- (c) The design strength in bending shall be taken as ϕM_{uo} , where ϕ is determined from Item (b) (ii) of Table 2.3.

In the determination of ϕ , M_{ud} is the reduced ultimate strength of the cross-section in bending where $k_u = 0.4$ and the tensile force has been reduced to balance the reduced compressive force.

M_{ud} may be calculated by assuming that —

- (i) there are no axial forces acting on the cross-section;
- (ii) the concrete strain at the extreme compression fibre is 0.003;
- (iii) the effective depth (d) is calculated for M_{uo} ;
- (iv) k_u is reduced to 0.4; and
- (v) the resultant of the tensile forces in the reinforcement and tendon is equal to the reduced compressive force calculated on the above assumptions.

8.1.4 Minimum strength requirements

8.1.4.1 General

The ultimate strength in bending (M_{uo}), at critical sections shall not be less than $(M_{uo})_{min}$, given by —

$$(M_{uo})_{min} = 1.2 [Z(f'_{cf} + P/A_g) + Pe]$$

where

Z = the section modulus of the uncracked section, referred to the extreme fibre at which flexural cracking occurs

f'_{cf} = the characteristic flexural tensile strength of the concrete

e = the eccentricity of the prestressing force (P), measured from the centroidal axis of the uncracked section

This requirement may be waived at some critical sections of an indeterminate member provided it can be demonstrated that this will not lead to sudden collapse of a span.

- A1 | For rectangular reinforced concrete cross-sections, the requirement that $M_{uo} \geq (M_{uo})_{min}$ shall be deemed to be satisfied for the direction of bending being considered if minimum tensile reinforcement is provided such that —

$$A_{st} / bd \geq 0.22 (D/d)^2 f'_{cf} / f_{sy}$$

8.1.4.2 Prestressed beams at transfer

The strength of a prestressed beam at transfer shall be checked using the load combinations specified in Clause 3.3.1 and a strength reduction factor (ϕ) for the section of 0.6.

This requirement shall be deemed to be satisfied if the maximum compressive stress in the concrete, under the loads at transfer, does not exceed $0.5f_{cp}$.

8.1.5 Stress in reinforcement and bonded tendons at ultimate strength

The stress in the reinforcement at ultimate strength shall be taken as not greater than f_{sy} .

In the absence of a more accurate calculation and provided that the minimum effective stress in the tendons is not less than $0.5f_p$, the maximum stress which would be reached in bonded tendons at ultimate strength (σ_{pu}) shall be taken as —

$$\sigma_{pu} = f_p \left(1 - \frac{k_1 k_2}{\gamma} \right)$$

where

$$k_1 = 0.4 \text{ generally; or}$$

$$\text{if } f_{py} / f_p \geq 0.9,$$

$$k_1 = 0.28; \text{ and}$$

$$k_2 = \frac{1}{b_{ef} d_p f'_c} [A_{pt} f_p + (A_{st} - A_{sc}) f_{sy}]$$

Compression reinforcement may only be taken into account if d_{sc} is not greater than $0.15d_p$, in which case k_2 shall be taken as not less than 0.17.

8.1.6 Stress in tendons not yet bonded

Where the tendon is not yet bonded, the stress in the tendon at ultimate strength (σ_{pu}) shall be determined from the formula given in Item (a) below if the span-to-depth ratio is 35 or less, or from the formula given in Item (b) below if the span-to-depth ratio is greater than 35 but in no case shall σ_{pu} be taken greater than f_{py} —

$$(a) \quad \sigma_{pu} = \sigma_{p,ef} + 70 + \frac{f'_c b_{ef} d_p}{100 A_{pt}} \leq \sigma_{p,ef} + 400$$

$$(b) \quad \sigma_{pu} = \sigma_{p,ef} + 70 + \frac{f'_c b_{ef} d_p}{300 A_{pt}} \leq \sigma_{p,ef} + 200$$

where $\sigma_{p,ef}$ is the effective stress in the tendon after allowing for all losses.

8.1.7 Spacing of reinforcement and tendons

The minimum clear distance between parallel bars (including bundled bars), ducts and tendons shall be such that the concrete can be properly placed and compacted in accordance with Clause 19.1.3. The maximum spacing of longitudinal reinforcement and tendons shall be determined in accordance with Clause 8.6.

A1 | 8.1.8 Detailing of flexural reinforcement and tendons

8.1.8.1 General procedure for detailing reinforcement and tendons

A1 | The detailing of flexural reinforcement and tendons, including termination, anchorage and debonding, shall be based on a hypothetical bending-moment diagram formed by uniformly displacing the calculated positive and negative bending moment envelopes a distance D along the beam from each side of the relevant section of maximum moment.

8.1.8.2 Distribution of reinforcement

Tensile reinforcement shall be well distributed in zones of maximum concrete tension, including those portions of flanges of T-beams, L-beams and I-beams over a support.

8.1.8.3 Continuation of negative moment reinforcement

Not less than one-third of the total negative moment tensile reinforcement required at a support shall be extended a distance D beyond the point of contra-flexure.

8.1.8.4 Anchorage of positive moment reinforcement

Anchorage of positive moment reinforcement shall comply with the following requirements:

- (a) At a simple support, sufficient positive moment reinforcement shall be anchored past the face of the support for a length L_{st} such that the anchored reinforcement can develop a tensile force of $1.5V^*$ at the face of the support, where V^* is the design shear force at a distance, d , from that face and L_{st} is determined from Clause 13.1.2.3.
- (b) At a simple support, of the tensile reinforcement required at mid-span, not less than either—
 - (i) one-half shall extend past the face of the support for a length of $12d_b$ or an equivalent anchorage; or
 - (ii) one-third shall extend past the face of the support for a length of $8d_b$ plus $D/2$.
- (c) At a support where the beam is continuous or flexurally restrained, not less than one quarter of the total positive moment reinforcement required at midspan shall continue past the near face of the support.

8.1.8.5 Shear strength requirements near terminated flexural reinforcement

If tensile reinforcement is terminated, the effect on the shear strength shall be assessed in accordance with the principles of the truss analogy.

This requirement shall be deemed to be satisfied if any one of the following conditions is met:

- (a) Not more than a quarter of the maximum tensile reinforcement is terminated within any distance $2D$.
- (b) At the cut-off point, $\phi V_u \geq 1.5V^*$.
- (c) Stirrups are provided to give an area of shear reinforcement of $A_{sv} + A_{sv,min.}$ for a distance D along the terminated bar from the cut-off point, where A_{sv} and $A_{sv,min.}$ are determined in accordance with Clause 8.2.

8.1.8.6 Deemed to comply arrangement of flexural reinforcement

For continuous reinforced beams where the ratio of the longer to the shorter length of any two adjacent spans does not exceed 1.2 and where the loads are uniformly distributed and the live load (q) does not exceed twice the dead load (g) compliance with the following shall be deemed to satisfy the requirements of Clauses 8.1.8.2 to 8.1.8.5.

- (a) Of the negative moment tensile reinforcement provided at the support—
 - (i) not less than one-quarter shall extend over the whole span;
 - (ii) not less than one-half shall extend $0.3L_n$ or more beyond the face of the support; and
 - (iii) the remainder, if any, shall extend $0.2L_n$ or more beyond the face of the support.
 Where adjacent spans are unequal, the extension of negative reinforcement beyond each face of the common support shall be based on the longer span.
- (b) Of the positive moment tensile reinforcement provided at mid-span—
 - (i) not less than one-half shall extend into a simple support for a length of $12d_b$;
 - (ii) not less than one-quarter shall extend into a support where the beam is continuous or flexurally restrained; and
 - (iii) the remainder, if any, shall extend to within $0.1L_n$ from the face of the support.
- (c) To comply with shear requirements, not more than a quarter of the maximum tensile reinforcement shall be terminated within any distance $2D$.

8.1.8.7 *Restraint of compression reinforcement*

Compression reinforcement required for strength in beams shall be adequately restrained by fitments in accordance with Clause 10.7.3.

8.1.8.8 *Bundled bars*

Groups of parallel longitudinal bars bundled to act as a unit shall —

- (a) have not more than four bars in any one bundle;
- (b) be tied together in contact; and
- (c) be enclosed within stirrups or ties.

Individual bars within a bundle, terminated within the span of flexural members, shall terminate at different points staggered by at least 40 times the diameter of the larger bar.

The unit of bundled bars shall be treated as an equivalent single bar of diameter derived from the total area of the bars in the bundle.

8.1.8.9 *Detailing of tendons*

In prestressed members—

- (a) the tendons shall be arranged so that the flexural strength required by Clause 8.1.8.1 is achieved in all cross-sections;
- (b) anchorages and stress development, as appropriate, shall be provided for all tendons in accordance with Sections 12 and 13; and
- (c) at a simple support of a pretensioned member, at least one-third of the tendons required at the section of maximum positive moment shall be continued to the end of the member without debonding.

8.2 STRENGTH OF BEAMS IN SHEAR**8.2.1 Application**

This Clause applies to reinforced and prestressed beams —

- (a) subjected to shear force, bending moment and axial force; or
- (b) subjected to shear force, bending moment and axial force in combination with torsion, provided that the additional requirements given in Clause 8.3 are complied with.

This Clause does not apply to non-flexural members covered by Section 12.

8.2.2 Design shear strength of a beam

The design shear strength of a beam shall be taken as ϕV_u where either —

- (a) $V_u = V_{uc} + V_{us}$, taking account of Clauses 8.2.3 to 8.2.6, where V_{uc} is determined from Clause 8.2.7 and V_{us} is determined from Clauses 8.2.9 and 8.2.10; or
- (b) V_u is calculated by means of a method based on the truss analogy, in which case Clauses 8.2.3 to 8.2.10 may not apply.

8.2.3 Tapered members

In members that are tapered along their length, the components of inclined tension or compression forces shall be taken into account in the calculation of shear strength.

8.2.4 Maximum transverse shear near a support

The maximum transverse shear near a support shall be taken as the shear at —

- (a) the face of the support; or

- (b) a distance of d_o from the face of the support, provided that —
- (i) diagonal cracking can not take place at the support or extend into it;
 - (ii) there are no concentrated loads closer than $2d_o$ from the face of the support;
 - (iii) the value of β_3 in Clauses 8.2.7.1 and 8.2.7.2 is taken to be equal to one; and
 - (iv) the transverse shear reinforcement required at d_o from the support is continued unchanged to the face of the support.

In both Items (a) and (b) above, longitudinal tensile reinforcement required at d_o from the face of the support shall be continued onto the support and shall be fully anchored past that face.

8.2.5 Requirements for shear reinforcement

The following requirements for shear reinforcement shall apply:

- (a) Where $V^* \leq 0.5\phi V_{uc}$, no shear reinforcement is required, except that where the overall depth of the beam exceeds 750 mm, minimum shear reinforcement shall be provided in accordance with Clause 8.2.8.
- (b) Where $0.5\phi V_{uc} < V^* \leq \phi V_{u.min.}$, minimum shear reinforcement ($A_{sv.min.}$) shall be provided in accordance with Clause 8.2.8.
- (c) The minimum shear reinforcement requirements of Items (a) and (b) may be waived—
 - (i) for beams, if $V^* \leq \phi V_{uc}$ and D does not exceed the greater of 250 mm and half the width of the web; and
 - (ii) for slabs to which this Clause applies, if $V^* \leq \phi V_{uc}$.
- (d) Where $V^* > \phi V_{u.min.}$ shear reinforcement shall be provided in accordance with Clause 8.2.10.

8.2.6 Shear strength limited by web crushing

In no case shall the ultimate shear strength (V_u) be taken as greater than —

$$V_{u.max.} = 0.2 f'_c b_v d_o + P_v$$

where

$$b_v = (b_w - 0.5\Sigma d_d)$$

Σd_d = the sum of the diameters of the grouted ducts, if any, in a horizontal plane across the web

P_v = the vertical component of the prestressing force at the section under consideration

8.2.7 Shear strength of a beam excluding shear reinforcement

8.2.7.1 Reinforced beams

The ultimate shear strength (V_{uc}) of a reinforced beam, excluding the contribution of shear reinforcement, shall be calculated from the following equation:

$$V_{uc} = \beta_1 \beta_2 \beta_3 b_v d_o \left(\frac{A_{st} f'_c}{b_v d_o} \right)^{1/3}$$

where

$$\beta_1 = 1.1(1.6 - d_o/1000) \geq 1.1$$

$$\beta_2 = 1; \text{ or}$$

$$= 1 - (N^*/3.5A_g) \geq 0 \text{ for members subject to significant axial tension; or}$$

$$= 1 + (N^*/14A_g) \text{ for members subject to significant axial compression}$$

$$\beta_3 = 1; \text{ or may be taken as —}$$

$$= 2d_o/a_v \text{ but not greater than 2, provided that the applied loads and the support are orientated so as to create diagonal compression over the length } a_v$$

$$A_{st} = \text{cross-sectional area of longitudinal reinforcement provided in the tension zone and fully anchored at the cross-section under consideration}$$

8.2.7.2 Prestressed beams

The ultimate shear strength (V_{uc}) of a prestressed beam, excluding the contribution of shear reinforcement, shall be taken as not greater than the lesser of the values obtained from the following, unless the cross-section under consideration is cracked in flexure, in which case only Item (a) applies:

(a) Flexure-shear cracking

$$V_{uc} = \beta_1 \beta_2 \beta_3 b_v d_o \left[\frac{(A_{st} + A_{pt}) f'_c}{b_v d_o} \right]^{1/3} + V_o + P_v$$

where

β_1 , β_2 , β_3 and A_{st} are as given in Clause 8.2.7.1 except that in determining β_2 , N^* is taken as the value of the axial force excluding prestress

V_o = the shear force which would occur at the section when the bending moment at that section was equal to the decompression moment (M_o) given by—

$$M_o = Z \sigma_{cp,f}$$

where

$\sigma_{cp,f}$ = the compressive stress due to prestress, at the extreme fibre where cracking occurs

For simply supported conditions,

$$V_o = M_o / (M^* / V^*)$$

where M^* and V^* are the bending moment and shear force respectively, at the section under consideration, due to the same design loading

For statically indeterminate structures, shear forces and bending moments, due to the secondary effects of prestress, shall be taken into account when determining M_o and V_o .

(b) Web-shear cracking

$$V_{uc} = V_t + P_v$$

where

V_t = the shear force, which, in combination with the prestressing force and other action effects at the section, would produce a principal tensile stress of $0.33\sqrt{f'_c}$ at either the centroidal axis or the intersection of flange and web, whichever is the more critical

8.2.7.3 Secondary effects on V_{uc}

Where stresses due to secondary effects such as creep, shrinkage and differential temperature are significant, they shall be taken into account in the calculation of V_{uc} .

NOTE: Where significant reversal of loads may occur, causing cracking in a zone usually in compression, the value of V_{uc} obtained from Clause 8.2.7.1 may not apply.

8.2.8 Minimum shear reinforcement

The minimum area of shear reinforcement ($A_{sv,min.}$) provided in a beam shall be given by:

$$A_{sv,min.} = 0.35b_v s / f_{sy,f}$$

8.2.9 Shear strength of a beam with minimum reinforcement

The ultimate shear strength of a beam provided with minimum shear reinforcement ($A_{sv,min.}$) shall be taken as —

$$V_{u,min.} = V_{uc} + 0.6b_v d_o$$

8.2.10 Contribution to shear strength by the shear reinforcement

The contribution to the ultimate shear strength by shear reinforcement in a beam (V_{us}) shall be determined from the following equations:

(a) For perpendicular shear reinforcement:

$$V_{us} = (A_{sv} f_{sy,f} d_o / s) \cot \theta_v$$

(b) For inclined shear reinforcement:

$$V_{us} = (A_{sv} f_{sy,f} d_o / s) (\sin \alpha_v \cot \theta_v + \cos \alpha_v)$$

where, for both Items (a) and (b) —

s = the centre-to-centre spacing of shear reinforcement, measured parallel to the longitudinal axis of the member

θ_v = the angle between the axis of the concrete compression strut and the longitudinal axis of the member, taken conservatively as 45° or, more accurately, to vary linearly from 30° when $V^* = \phi V_{u,min.}$ to 45° when $V^* = \phi V_{u,max.}$

α_v = angle between the inclined shear reinforcement and the longitudinal tensile reinforcement

8.2.11 Suspension reinforcement

If forces are applied to a beam in such a way that hanging action is required, reinforcement or tendons shall be provided to carry all the forces concerned.

8.2.12 Detailing of shear reinforcement

8.2.12.1 Types

Shear reinforcement shall comprise one or more of —

- (a) stirrups or ties making an angle of between 45° and 90° with the longitudinal bars; and
- (b) welded wire mesh placed to have wires perpendicular to the axis of the beam.

8.2.12.2 Spacing

Shear reinforcement shall be spaced longitudinally not further apart than $0.5D$ or 300 mm, whichever is less. Where $V^* \leq \phi V_{u,\min.}$, the spacing may be increased to $0.75D$ or 500 mm, whichever is less.

The maximum transverse spacing across the width of the member shall not exceed the lesser of 600 mm and D .

8.2.12.3 Extent

Shear reinforcement, of area not less than that calculated as being necessary at any cross-section, shall be provided for a distance D from that cross-section in the direction of decreasing shear. The first fitment at each end of a span shall be positioned not more than 50 mm from the face of the adjacent support.

Shear reinforcement shall extend as close to the compression face and the tension face of the member as cover requirements and the proximity of other reinforcement and tendons will permit.

A1 8.2.12.4 Anchorage of shear reinforcement

The anchorage of shear reinforcement transverse to the longitudinal flexural reinforcement may be achieved by hooks, cogs, welding of the transverse bars or welded splices.

NOTE: The type of anchorage used should not induce splitting or spalling of the concrete cover.

Shear reinforcement shall be deemed to be adequately anchored provided the following requirements are met:

- (a) Bends in bars used as fitments shall enclose a longitudinal bar with a diameter larger than the diameter of the fitment bar. The enclosed bar shall be in contact with the fitment bend.
- (b) A fitment hook should be located preferably in the compression zone of the structural member, where anchorage conditions are most favourable. Such an anchorage is considered satisfactory, if the hook consists of a 135° or 180° bend with a nominal internal diameter of $4d_b$ plus a straight extension of $10d_b$ or 100 mm, whichever is the greater.
- (c) Where a fitment hook is located in the tension zone, the anchorage described in Item (b) is deemed to be satisfactory provided the stirrup spacing calculated using Clause 8.2.10 is multiplied by 0.8 and the maximum spacing specified in Clause 8.2.12.2 is also multiplied by 0.8.
- (d) Notwithstanding the above, fitment cogs shall not be used when the anchorage of the fitment is solely in the cover concrete of the beam.

A1

8.2.12.5 End anchorage of mesh

Where mesh is used as shear reinforcement, the ends shall be anchored —

- (a) in accordance with Clause 8.2.12.4, if the wires are bent at least to the dimensions of a standard fitment hook; or
- (b) by embedding two or more transverse wires at least 25 mm within the compression zone.

8.3 STRENGTH OF BEAMS IN TORSION

8.3.1 Application

This Clause applies to beams subjected to torsion combined with flexure and shear. It does not apply to non-flexural members covered by Section 12.

8.3.2 Torsion redistribution

Where torsional strength is not required for the equilibrium of the structure and the torsion in a member is induced solely by the angular rotation of adjoining members, it shall be permissible to disregard the torsional stiffness in the analysis and torsion in the member, if the torsion reinforcement requirements of Clauses 8.3.7 and the detailing requirements of Clause 8.3.8 are satisfied.

8.3.3 Torsional strength limited by web crushing

To prevent web crushing under the combined action of torsion and flexural shear, beams shall be proportioned so that the following inequality is satisfied:

$$\frac{T^*}{\phi T_{u,\max.}} + \frac{V^*}{\phi V_{u,\max.}} \leq 1$$

where $\phi V_{u,\max.}$ is calculated from Clause 8.2.6 and —

$$T_{u,\max.} = 0.2 f'_c J_t$$

The torsional modulus (J_t) may be taken as —

$$= 0.4x^2y \text{ for solid rectangular sections}$$

$$= 0.4\Sigma x^2y \text{ for solid T-, L-, or I-shaped sections, and}$$

$$= 2A_m b_w \text{ for thin walled hollow sections, } A_m \text{ being the area enclosed by the median lines of the walls of a single cell}$$

8.3.4 Requirements for torsional reinforcement

Requirements for torsional reinforcement shall be determined from the following:

(a) Torsional reinforcement is not required if—

(i) $T^* < 0.25\phi T_{uc}$; or

(ii) $\frac{T^*}{\phi T_{uc}} + \frac{V^*}{\phi V_{uc}} \leq 0.5$; or

(iii) the overall depth does not exceed the greater of 250 mm and half the width of the web, and

$$\frac{T^*}{\phi T_{uc}} + \frac{V^*}{\phi V_{uc}} \leq 1$$

where T_{uc} and V_{uc} are calculated in accordance with Clauses 8.3.5 and 8.2.7 respectively.

- (b) If Item (a) above is not satisfied, torsional reinforcement, consisting of transverse closed ties and longitudinal reinforcement shall be provided so that the following inequality is satisfied:

$$\frac{T^*}{\phi T_{us}} + \frac{V^*}{\phi V_{us}} \leq 1$$

where T_{us} is calculated in accordance with Clause 8.3.5, considering all the closed ties provided and V_{us} is calculated in accordance with Clause 8.2.10, considering all the closed and open ties provided.

Longitudinal torsional reinforcement shall comply with Clause 8.3.6 and both transverse and longitudinal torsional reinforcement shall comply with Clause 8.3.7.

8.3.5 Torsional strength of a beam

For the purpose of Clause 8.3.4, the ultimate strength of a beam in pure torsion (T_{uc} or T_{us}) shall be determined from the following:

- (a) For a beam without closed ties, the ultimate strength in pure torsion (T_{uc}) shall be calculated from—

$$T_{uc} = J_t \left(0.3 \sqrt{f'_c} \right) \sqrt{(1 + 10 \sigma_{cp} / f'_c)}$$

- (b) For a beam with closed ties, the ultimate strength in pure torsion (T_{us}) shall be calculated from—

$$T_{us} = f_{sy,f} \left(A_{sw} / s \right) 2A_t \cot \theta_t$$

where

A_t = the area of a polygon with vertices at the centre of longitudinal bars at the corners of the cross-section

θ_t = the angle between the axis of the concrete compression strut and the longitudinal axis of the member, taken conservatively as 45° or, more accurately, to vary linearly from 30° when $T^* = \phi T_{uc}$ to 45° when $T^* = \phi T_{u,max}$.

8.3.6 Longitudinal torsional reinforcement

Longitudinal torsional reinforcement shall be provided to resist the following design tensile forces, taken as additional to any design tensile forces due to flexure:

- (a) In the flexural tensile zone, a force of—

$$0.5 f_{sy,f} \left(\frac{A_{sw}}{s} \right) u_t \cot^2 \theta_t; \text{ and}$$

- (b) In the flexural compressive zone, a force of—

$$0.5 f_{sy,f} \left(\frac{A_{sw}}{s} \right) u_t \cot^2 \theta_t - F_c^*; \text{ but not less than zero,}$$

where

u_t = the perimeter of the polygon defined for A_t .

F_c^* = the absolute value of the design force in the compression zone due to flexure

8.3.7 Minimum torsional reinforcement

Where torsional reinforcement is required as specified in Clause 8.3.4 —

- (a) all of the minimum shear reinforcement required by Clause 8.2.8 shall be provided in the form of closed ties; and
- (b) longitudinal torsional reinforcement shall be provided in accordance with Clause 8.3.6.

8.3.8 Detailing of torsional reinforcement

Torsional reinforcement shall be detailed in accordance with the following:

- (a) Torsional reinforcement shall consist of both closed ties and longitudinal reinforcement.
- (b) The closed ties shall be continuous around all sides of the cross-section and anchored so as to develop full strength at any point, unless a more refined analysis shows that over part of the tie full anchorage is not required. The spacing (s) of the closed ties shall not be greater than the lesser of $0.12u_t$ and 300 mm.
- (c) The longitudinal reinforcement shall be placed as close as practicable to the corners of the cross-section, and in all cases at least one longitudinal bar shall be provided at each corner of the closed ties.

8.4 LONGITUDINAL SHEAR IN BEAMS

8.4.1 Application

This Clause applies to the transfer of longitudinal shear forces, across interface shear planes through webs and flanges of composite beams, and across shear planes through flanges cast monolithically.

8.4.2 Design shear force

For the purpose of this Clause, the design longitudinal shear force acting on a shear plane shall be taken as follows:

- (a) For a shear plane through a flange, equal to $V^* A_1/A_2$
where
 - (i) for a flange in compression —
 A_1/A_2 = the ratio of the area of flange outstanding beyond the shear plane to the total area of flange;
 - (ii) for a flange in tension —
 A_1/A_2 = the ratio of the area of longitudinal reinforcement in the flange outstanding beyond the shear plane to the total area of longitudinal tensile reinforcement
- (b) For a shear plane through the web, equal to V^* .

8.4.3 Design shear strength

The design longitudinal shear strength shall be taken as ϕV_{uf} where —

$$V_{uf} = \beta_4 A_s f_{sy} d/s + \beta_5 b_f d f'_{ct} \leq 0.2 f'_c b_f d$$

where

- β_4, β_5 = the shear plane surface coefficients given in Clause 8.4.4
 A_s = cross-sectional area of reinforcement anchored each side of the shear plane
 f_{sy} = the yield strength of the reinforcement crossing the shear plane
 d = effective depth of the composite beam
 s = spacing of reinforcement crossing the shear plane
 b_f = the width of the shear interface
 f'_{ct} = the characteristic principal tensile strength of the concrete

8.4.4 Shear plane surface coefficients

The shear plane surface coefficients, β_4 and β_5 , for the surface condition of the shear plane, shall be determined from Table 8.4.4, except that where the beam is subject to high levels of differential shrinkage, temperature effects, tensile stress, or fatigue effects across the shear plane, the value of β_5 should be reduced.

TABLE 8.4.4
SHEAR PLANE SURFACE COEFFICIENTS

Surface condition of the shear plane	Coefficients	
	β_4	β_5
A smooth surface, as obtained by casting against a form, or finished to a similar standard	0.6	0.1
A surface trowelled or tamped, so that the fines have been brought to the top, but where some small ridges, indentations or undulations have been left; slip-formed and vibro-beam screeded; or produced by some form of extrusion technique	0.6	0.2
A surface deliberately roughened —	0.9	0.4
(a) by texturing the concrete to give a pronounced profile;		
(b) by compacting but leaving a rough surface with coarse aggregate protruding but firmly fixed in the matrix;		
(c) by spraying when wet, to expose the coarse aggregate without disturbing it; or		
(d) by providing mechanical shear keys.		
Monolithic construction	0.9	0.5

8.4.5 Shear plane reinforcement

Where reinforcement is required to increase the longitudinal shear strength, the reinforcement shall consist of shear reinforcement anchored to develop its full strength at the shear plane. Shear and torsional reinforcement already provided, and which crosses the shear plane, may be taken into account for this purpose.

An area of shear reinforcement not less than $0.35b_f s/f_{sy,f}$ shall be provided.

8.4.6 Minimum thickness of structural components

The average thickness of structural components subject to interface shear shall be not less than 50 mm with a minimum local thickness not less than 30 mm.

8.5 DEFLECTION OF BEAMS

8.5.1 General

The deflection of a beam shall be determined in accordance with Clause 8.5.2 or Clause 8.5.3.

Alternatively, for reinforced beams, the span-to-effective depth ratio shall comply with Clause 8.5.4.

8.5.2 Beam deflection by refined calculation

The calculation of the deflection of a beam by refined calculation shall make allowance for the following:

- (a) Shrinkage and creep properties of the concrete.
- (b) Expected load history.
- (c) Cracking and tension stiffening.

8.5.3 Beam deflection by simplified calculation

8.5.3.1 Short-term deflection

The short-term deflections due to external loads and prestressing, which occur immediately on their application, shall be calculated using the value of E_{ci} determined in accordance with Clause 6.1.2 and the value of the effective second moment of area of the member (I_{ef}). This value of I_{ef} may be determined from the values of I_{ef} at nominated cross-sections as follows:

- (a) For a simply supported span, the value at midspan.
- (b) In a continuous beam—
 - (i) for an interior span, half the midspan value plus one quarter of each support value; or
 - (ii) for an end span, half the midspan value plus half the value at the continuous support.
- (c) For a cantilever, the value at the support.

For the purpose of the above determinations, the value of I_{ef} at each of the cross-sections nominated in Items (a) to (c) above is given by—

A1

$$I_{ef} = I_{cr} + (I - I_{cr}) \left(M_{cr} / M_s^* \right)^3 \leq I_{e,max.}$$

where

$$I_{e,max.} = I, \text{ for prestressed sections}$$

$$= I, \text{ for reinforced sections when } p = \frac{A_{st}}{bd} \geq 0.005$$

$$= 0.6 I, \text{ for reinforced sections when } p = \frac{A_{st}}{bd} < 0.005$$

where

b = width of the cross-section at the compression face

A1

M_s^* = the maximum bending moment at the section, based on the short-term serviceability load or the construction load

$$M_{cr} = Z(f'_{cf} - f_{cs} + P/A_g) + Pe \geq 0.0$$

where

Z = the section modulus of the uncracked section, referred to the extreme fibre at which cracking occurs

f'_{cf} = the characteristic flexural tensile strength of concrete

f_{cs} = the maximum shrinkage-induced tensile stress on the uncracked section at the extreme fibre at which cracking occurs, and for a singly reinforced section may be taken as

$$= \left(\frac{1.5p}{1 + 50p} E_s \varepsilon_{cs} \right)$$

p = $(A_{st} + A_{pt})/bd$

ε_{cs} = the design shrinkage strain determined in accordance with Clause 6.1.7

Alternatively, as a further simplification but only for reinforced members, I_{ef} at each nominated cross-section for rectangular sections, may be taken as—

$$I_{ef} = (0.02 + 2.5p)bd^3 \text{ when } p \geq 0.005$$

$$I_{ef} = (0.1 - 13.5p)bd^3 \leq 0.06 bd^3 \text{ when } p < 0.005$$

8.5.3.2 Long-term deflection

For reinforced or prestressed beams, that part of the deflection that occurs after the short-term deflection shall be calculated as the sum of—

- the shrinkage component of the long-term deflection, determined from the estimated shrinkage properties of the concrete and the principles of mechanics; and
- the additional long-term creep deflections, determined by multiplying the short-term concrete deformations due to loads and prestress by appropriate creep coefficients.

8.5.3.3 Multiplier method for long-term deflection of reinforced beams

In the absence of more accurate calculations, the additional long-term deflection of a reinforced beam due to creep and shrinkage may be calculated by multiplying the short-term deflection caused by the sustained load considered, by a multiplier, k_{cs} , given by—

$$k_{cs} = [2 - 1.2(A_{sc}/A_{st})] \geq 0.8$$

where A_{sc}/A_{st} is taken at—

- midspan, for a simply supported or continuous beam; or
- the support, for a cantilever beam.

8.5.4 Deemed to comply span-to-depth ratios for reinforced beams

For reinforced beams of uniform cross-section, fully propped during construction, subject to uniformly distributed loads only and where the live load (q) does not exceed the dead load (g), beam deflections shall be deemed to comply with the requirements of Clause 2.4.2 if the ratio of effective span to effective depth is not greater than the value given by—

$$L_{ef}/d = \left[\frac{k_1 (\Delta/L_{ef}) b_{ef} E_c}{k_2 F_{d,ef}} \right]^{1/3}$$

where

Δ/L_{ef} = the deflection limit selected in accordance with Clause 2.4.2

$F_{d,ef}$ = the effective design load per unit length, taken as—

- (a) $(1.0 + k_{cs})g + (\psi_s + k_{cs} \psi_1)q$ for total deflection; or
- (b) $k_{cs} g + (\psi_s + k_{cs} \psi_1)q$ for the deflection that occurs after the addition or attachment of the partitions

where

k_{cs} is determined in accordance with Clause 8.5.3.3 and ψ_s and ψ_1 are given in AS 1170.1

k_1 = I_{ef}/bd^3 , which may be taken as
 = $0.02 + 2.5p$ for rectangular sections where $p \geq 0.005$
 = $0.1 - 13.5p \leq 0.06$ for rectangular sections where $p < 0.005$

k_2 = the deflection constant, taken as—

- (a) for simply-supported beams, $5/384$; or
- (b) for continuous beams, where in adjacent spans the ratio of the longer span to the shorter span does not exceed 1.2 and where no end span is longer than an interior span—
 - (i) $2.4/384$ in an end span; or
 - (ii) $1.5/384$ in interior spans

8.6 CRACK CONTROL OF BEAMS

8.6.1 Crack control for tension and flexure in reinforced beams

For the purpose of this Clause the following apply:

- (a) The resultant action is considered to be *primarily tension* when the whole of the section is in tension, or *primarily flexure* when the tensile stress distribution within the section prior to cracking is triangular with some part of the section in compression.
- (b) A critical tensile zone of a beam subject to flexure is defined as a region where the design bending moment at serviceability limit state ($M_{s,1}^*$) calculated with short-term load factor $\psi_s = 1.0$ (see Note 1), equals or exceeds the critical moment for flexural cracking (M_{crit}), which is calculated assuming a flexural tensile strength of concrete equal to 3.0 MPa.
- (c) Where the main reinforcement has different yield strengths, the yield strength (f_{sy}) shall be taken as the lowest yield strength of any of the reinforcement.

Cracking in reinforced beams subjected to tension, flexure with tension, or flexure, shall be deemed to be controlled if the appropriate requirements in Items (i) and (ii), and either Item (iii) for beams primarily in tension or Item (iv) for beams primarily in flexure, are satisfied. For regions of beams fully enclosed within a building except for a brief period of weather exposure during construction, and, where it is assessed that wider cracks can be tolerated, only Item (ii) need be satisfied.

- (i) The minimum area of reinforcement ($A_{st,min}$) in a beam primarily subject to tension, or in a critical tensile zone of a beam primarily subject to flexure shall be—

$$A_{st,min} = 3k_s A_{ct} / f_s$$

A1

where

k_s = a coefficient that takes into account the shape of the stress distribution within the section immediately prior to cracking, as well as the effect of non-uniform self-equilibrating stresses, and equals 0.8 for tension and 0.6 for flexure

A_{ct} = the area of concrete in the tensile zone, being that part of the section in tension assuming the section is uncracked

f_s = the maximum tensile stress permitted in the reinforcement immediately after formation of a crack, which shall be the lesser of the yield strength of the reinforcement f_{sy} and the maximum steel stress given in Table 8.6.1(A) for the largest nominal diameter, d_b , of the bars in the section

- (ii) The distance from the side or soffit of a beam to the centre of the nearest longitudinal bar shall not exceed 100 mm. Bars with a diameter less than half the diameter of the largest bar in the section shall be ignored. The centre-to-centre spacing of bars near a tension face of the beam shall not exceed 300 mm. For T-beams and L-beams, the reinforcement required in the flange shall be distributed across the effective width.
- (iii) For beams primarily subject to tension, the calculated steel stress (f_{scr}) shall not exceed the maximum steel stress given in Table 8.6.1(A) for the largest nominal diameter (d_b) of the bars in the section, and under direct loading the calculated steel stress ($f_{scr.1}$) shall not exceed $0.8f_{sy}$.
- (iv) For beams primarily subject to flexure, the calculated steel stress (f_{scr}) shall not exceed the maximum steel stress given in Table 8.6.1(A) for the largest nominal diameter (d_b), of the bars in the tensile zone, and under direct loading the calculated steel stress ($f_{scr.1}$) shall not exceed $0.8f_{sy}$. Alternatively, the calculated steel stress (f_{scr}) shall not exceed the maximum steel stress given in Table 8.6.1(B) for the largest centre-to-centre spacing of adjacent parallel bars in the tensile zone (see Note 2), and under direct loading the calculated steel stress $f_{scr.1}$ shall not exceed $0.8f_{sy}$. Bars with a diameter less than half the diameter of the largest bar in the section shall be ignored when determining spacing.

NOTES:

- 1 Design bending moments M_s^* and $M_{s.1}^*$ at the serviceability limit state will normally be estimated using elastic analysis. Inaccurate estimates may be obtained if they are determined from the design bending moments M^* at the strength limit state when the amount of moment redistribution is unknown; for example, if plastic methods of analysis are used for strength design.
- 2 If comparing the calculated steel stress (f_{scr}) with the maximum steel stresses determined from Tables 8.6.1(A) and 8.6.1(B) depending on the bar diameter and bar spacing, respectively, the greater of these two maximum steel stresses may be used.

TABLE 8.6.1(A)
MAXIMUM STEEL STRESS FOR TENSION
OR FLEXURE IN BEAMS

Nominal bar diameter (d_b) mm	Maximum steel stress MPa
10	360
12	330
16	280
20	240
24	210
28	185
32	160
36	140
40	120

NOTE: Values for other bar diameters may be calculated using the equation:
Maximum steel stress = $-173 \log_e (d_b) + 760$ MPa.

TABLE 8.6.1(B)
MAXIMUM STEEL STRESS FOR FLEXURE IN BEAMS

Centre-to-centre spacing mm	Maximum steel stress MPa
50	360
100	320
150	280
200	240
250	200
300	160

NOTE: Intermediate values may be calculated using the equation:
Maximum steel stress = $-0.8 \times$ centre-centre spacing + 400 MPa.

8.6.2 Crack control for flexure in prestressed beams

Flexural cracking, in a prestressed beam, shall be deemed to be controlled if, under the short-term service loads, the resulting maximum tensile stress in the concrete does not exceed $0.25 \sqrt{f'_c}$ or, if this stress is exceeded, by providing reinforcement or bonded tendons, or both, near the tensile face and limiting either—

- (a) the calculated maximum flexural tensile stress under short term service loads to $0.6 \sqrt{f'_c}$; or
- (b) both—
 - (i) the increment in steel stress near the tension face to 200 MPa, as the load increases from its value when the extreme concrete tensile fibre is at zero stress to the short-term service load value; and
 - (ii) the centre-to-centre spacing of reinforcement, including bonded tendons, to 200 mm.

8.6.3 Crack control in the side face of beams

For crack control in the side face of beams where the overall depth exceeds 750 mm, longitudinal reinforcement, consisting of 12 mm bars at 200 mm centres, or 16 mm bars at 300 mm centres, shall be placed in each side face.

8.6.4 Crack control at openings and discontinuities

Reinforcement shall be provided for crack control at openings and discontinuities in a beam.

8.7 VIBRATION OF BEAMS

Vibration of beams shall be considered and appropriate action taken where necessary to ensure that the vibrations induced by machinery, or vehicular or pedestrian traffic, will not adversely affect the serviceability of the structure.

8.8 T-BEAMS AND L-BEAMS

8.8.1 General

Where a slab is assumed to provide the flange of a T-beam or L-beam, the longitudinal shear capacity of the flange-web connection shall be checked in accordance with Clause 8.4.

For isolated T-beams or L-beams, the shear strength of the slab flange on vertical sections parallel to the beam shall also be checked in accordance with Clause 8.2.

8.8.2 Effective width of flange for strength and serviceability

In the absence of a more accurate determination, the effective width of the flange of a T-beam or L-beam for strength and serviceability shall be taken as—

- (a) T-beams $b_{ef} = b_w + 0.2a$; and
 (b) L-beams $b_{ef} = b_w + 0.1a$

where a is the distance between points of zero bending moment, which for continuous beams, may be taken as $0.7L$.

In both Items (a) and (b) above, the overhanging part of the flange considered effective shall not exceed half the clear distance to the next member. The effective width so determined may be taken as constant over the entire span.

8.9 SLENDERNESS LIMITS FOR BEAMS

8.9.1 General

Unless a stability analysis is carried out, beams shall comply with the limits specified in Clauses 8.9.2 to 8.9.4, as appropriate.

8.9.2 Simply supported and continuous beams

For a simply supported or continuous beam, the distance L_1 between points at which lateral restraint is provided shall be such that L_1/b_{ef} does not exceed the lesser of $180b_{ef}/D$ and 60.

8.9.3 Cantilever beams

For a cantilever beam having lateral restraint only at the support, the ratio of the clear projection L_n to the width, b_{ef} , at the support shall be such that L_n/b_{ef} does not exceed the lesser of $100b_{ef}/D$ and 25.

8.9.4 Reinforcement for slender prestressed beams

For a prestressed beam in which L_1/b_{ef} exceeds 30, or for a prestressed cantilever beam in which L_n/b_{ef} exceeds 12, the following reinforcement shall be provided:

- (a) Stirrups providing a steel area, A_{sv} , in accordance with Clause 8.2.8.
- (b) Additional longitudinal reinforcement, consisting of at least one bar in each corner of the compression face, such that—

$$A_{sc} \geq 0.35A_{pt}f_p / f_{sy}$$

SECTION 9 DESIGN OF SLABS FOR STRENGTH AND SERVICEABILITY

9.1 STRENGTH OF SLABS IN BENDING

9.1.1 General

The strength of a slab in bending shall be determined in accordance with Clauses 8.1.1 to 8.1.6 except that for two-way reinforced slabs, the minimum strength requirements of Clause 8.1.4.1 shall be deemed to be satisfied by providing minimum tensile reinforcement such that A_{st}/bd is not less than one of the following:

- (a) Slabs supported by columns 0.0025.
- (b) Slabs supported by beams or walls 0.002.
- (c) Slab footings 0.002.

9.1.2 Reinforcement and tendon distribution in two-way flat slabs

In two-way flat slabs, at least 25% of the total of the design negative moment in a column-strip and adjacent half middle-strips shall be resisted by reinforcement or tendons or both, located in a cross-section of slab centred on the column and of a width equal to twice the overall depth of the slab or drop panel plus the width of the column.

9.1.3 Detailing of tensile reinforcement in slabs

9.1.3.1 General procedure for arrangement

Tensile reinforcement shall be arranged in accordance with the following as appropriate:

- (a) Where the bending moment envelope has been calculated, the termination and anchorage of flexural reinforcement shall be based on a hypothetical bending-moment diagram formed by displacing the calculated positive and negative bending-moment envelopes a distance D along the slab from each side of the relevant sections of maximum moment. Nevertheless, the following shall apply:
 - (i) Not less than one-third of the total negative moment reinforcement required at a support shall be extended a distance $12d_b$ or D , whichever is greater, beyond the point of contraflexure.
 - (ii) At a simply supported discontinuous end of a slab, not less than one-half of the total positive moment reinforcement required at midspan shall be anchored by extension past the face of the support for a distance of $12d_b$ or D , whichever is greater, or by an equivalent anchorage.

Where no shear reinforcement is required in accordance with Clause 8.2.5 or Clause 9.2, the extension of the midspan positive moment reinforcement past the face of the support may be reduced to $8d_b$ if at least one-half of the reinforcement is so extended, or to $4d_b$ if all the reinforcement is so extended.
 - (iii) At a support where the slab is continuous or flexurally restrained, not less than one-quarter of the total positive moment reinforcement required at midspan shall continue past the near face of the support.
 - (iv) Where frames incorporating slabs are intended to resist lateral loading, the effects of such loading on the arrangement of the slab reinforcement shall be taken into account but in no case shall the lengths of reinforcement be made less than those shown in Figures 9.1.3.2 and 9.1.3.4, as appropriate.
- (b) Where the bending moment envelope has not been calculated, the requirements of Clauses 9.1.3.2. to 9.1.3.4, as appropriate to the type of slab, shall be satisfied.

9.1.3.2 Deemed-to-comply arrangement for one-way slabs

For one-way slabs continuous over two or more spans where—

- (a) the ratio of the longer to the shorter of any two adjacent spans does not exceed 1.2; and
- (b) the live loads may be assumed to be uniformly distributed and the live load (q) is not greater than twice the dead load (g),

the arrangement of tensile reinforcement shown in Figure 9.1.3.2 shall be deemed to comply with Clause 9.1.3.1(a).

Where adjacent spans are unequal, the extension of negative moment reinforcement beyond each face of the common support shall be based on the longer span.

For one-way slabs of single span, the arrangement of tensile reinforcement shown in Figure 9.1.3.2, for the appropriate end support conditions shall be deemed to comply with Clause 9.1.3.1(a).

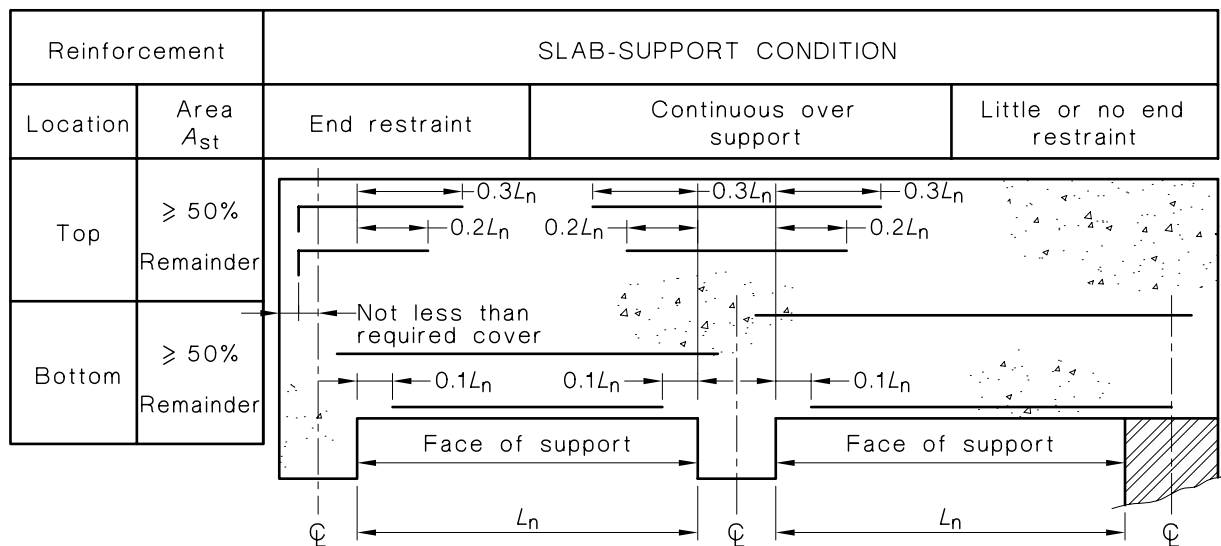

FIGURE 9.1.3.2 ARRANGEMENT OF REINFORCEMENT

9.1.3.3 Deemed-to-comply arrangement for two-way slabs supported on beams or walls

For two-way simply supported or continuous rectangular slabs supported by walls or beams on four sides, the arrangement of tensile reinforcement, shown in Figure 9.1.3.2 and further prescribed herein, shall be deemed to comply with Clause 9.1.3.1(a).

The arrangement shall apply to each direction.

Where a simply supported or continuous slab is not square, the arrangement shall be based on the span (L_n) taken as the shorter span.

Where adjacent continuous rectangular slabs have unequal shorter spans, the extension of negative moment reinforcement beyond each face of a common support shall be based on the span (L_n) taken as the longer of the shorter spans.

Negative moment reinforcement provided at a discontinuous edge shall extend from the face of the support into the span for a distance of 0.15 times the shorter span.

At an exterior corner of a two-way rectangular slab supported on four sides and restrained against uplift, reinforcement shall be provided in both the top and the bottom of the slab. This reinforcement shall consist of two layers perpendicular to the edges of the slab and extend from each edge for a distance not less than 0.2 times the shorter span. The area of the reinforcement in each of the four layers shall be not less than—

- (a) for corners where neither edge is continuous $0.75 A_{st}$; and
 - (b) for corners where one edge is continuous $0.5 A_{st}$,
- where A_{st} is the area of the maximum positive moment reinforcement required at midspan.

Any reinforcement provided may be considered as part of this reinforcement.

9.1.3.4 Deemed-to-comply arrangement for two-way flat slabs

For multispan, reinforced, two-way flat slabs, the arrangement of tensile reinforcement, shown in Figure 9.1.3.4 and further prescribed herein, shall be deemed to comply with Clause 9.1.3.1(a).

Where adjacent spans are unequal, the extension of negative moment reinforcement beyond each face of the common support shall be based on the longer span.

All slab reinforcement perpendicular to a discontinuous edge shall be extended (straight, bent or otherwise) past the internal face of the spandrel, wall or column for a length—

- (a) for positive moment reinforcement, not less than 150 mm except that it shall extend to the edge of the slab if there is no spandrel beam or wall; and
- (b) for negative moment reinforcement, such that the calculated force is developed at the internal face in accordance with Clause 13.1.

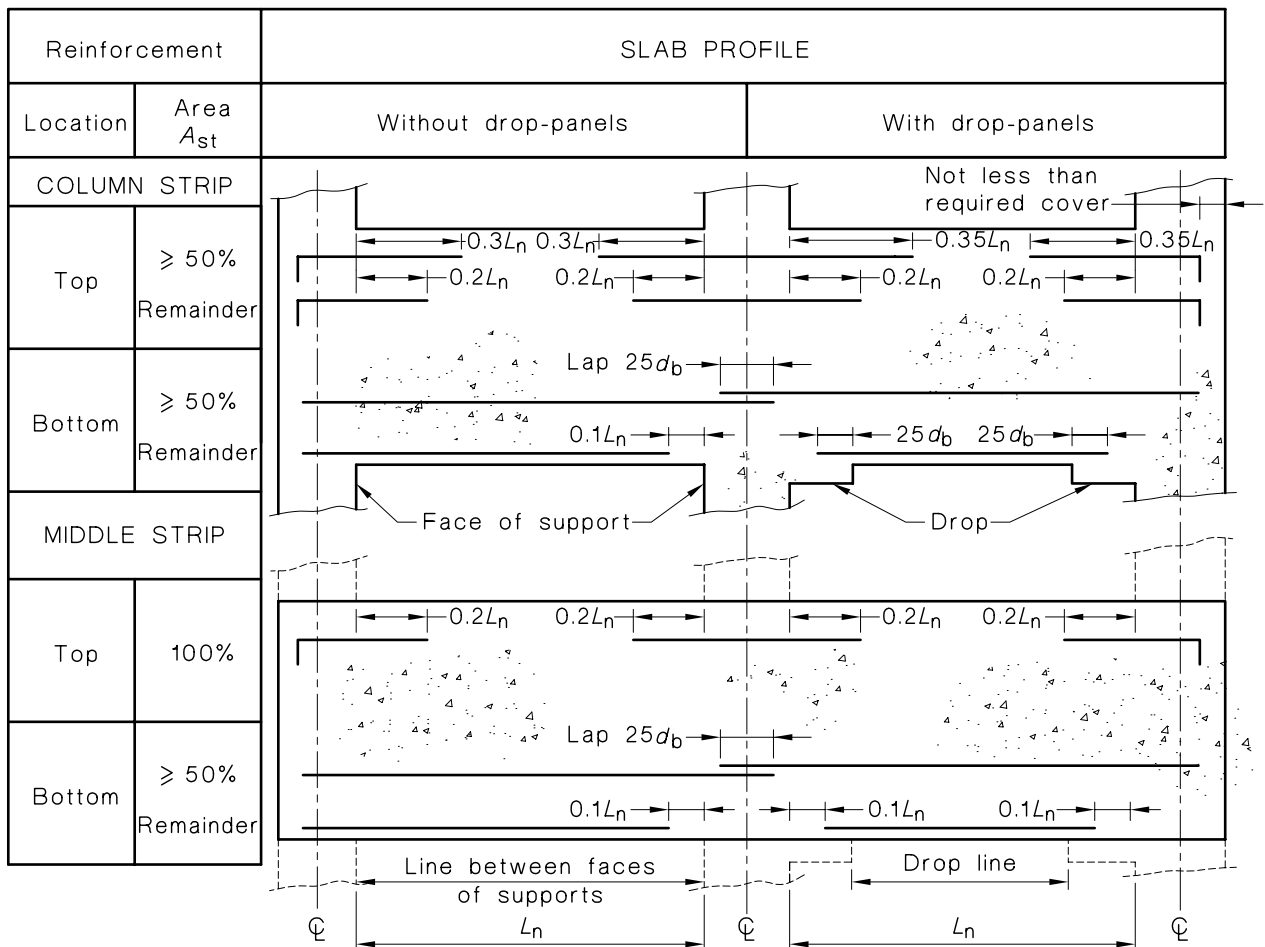

FIGURE 9.1.3.4 ARRANGEMENT OF REINFORCEMENT

9.1.4 Spacing of reinforcement and tendons

The minimum clear distance between parallel bars (including bundled bars), ducts and tendons shall be such that the concrete can be properly placed and compacted in accordance with Clause 19.1.3.

The maximum spacing of reinforcement and tendons shall be determined in accordance with Clause 9.4.

9.2 STRENGTH OF SLABS IN SHEAR

9.2.1 General

For the purpose of this Clause, the following definitions and symbols apply to flat slabs:

9.2.1.1 Critical shear perimeter

The perimeter defined by a line geometrically similar to the boundary of the effective area of a support or concentrated load and located at a distance of $d_{om}/2$ therefrom (see Figure 9.2.1(A)).

9.2.1.2 Critical opening

Any opening through the thickness of a slab where an edge, or part of the edge, of the opening is located at a clear distance of less than $2.5b_o$ from the critical shear perimeter (see Figure 9.2.1(A)).

9.2.1.3 Effective area of a support or concentrated load

The area totally enclosing the actual support or load and for which the perimeter is a minimum (see Figure 9.2.1(A)).

9.2.1.4 Torsion strip

A strip of slab of width a , whose longitudinal axis is perpendicular to the direction of M_v^* (see Figure 9.2.1(B)).

a = the dimension of the critical shear perimeter measured parallel to the direction of M_v^* (see Figure 9.2.1(B))

b_o = the dimension of an opening (see Figure 9.2.1(A))

b_w = the width of the web of a spandrel beam (see Figure 9.2.1(B))

D_b = the overall depth of a spandrel beam (see Figure 9.2.6)

D_s = the overall depth of a slab or drop panel as appropriate

d_{om} = the mean value of d_o , averaged around the critical shear perimeter

M_v^* = the bending moment transferred from the slab to a support in the direction being considered (see Figure 9.2.1(B))

u = the length of the critical shear perimeter (see Figure 9.2.1(A))

y_1 = the larger overall dimension of a closed tie (see Figure 9.2.6)

β_h = the ratio of the longest overall dimension of the effective loaded area, Y , to the overall dimension, X , measured perpendicular to Y (see Figure 9.2.1(A)).

9.2.2 Application

The strength of a slab in shear shall be determined in accordance with the following:

- (a) Where shear failure can occur across the width of the slab, the design shear strength of the slab shall be calculated in accordance with Clause 8.2.

(b) Where shear failure can occur locally around a support or concentrated load, the design shear strength of the slab shall be taken as ϕV_u , where V_u is calculated in accordance with one of the following, as appropriate:

- (i) Where M_v^* is zero, V_u is taken as equal to V_{uo} calculated in accordance with Clause 9.2.3.
- (ii) Where M_v^* is not zero, V_u is calculated in accordance with Clause 9.2.4.

9.2.3 Ultimate shear strength where M_v^* is zero

The ultimate shear strength of a slab where M_v^* is zero, V_{uo} , is given by either—

- (a) where there is no shear head—

$$V_{uo} = u d_{om} (f_{cv} + 0.3\sigma_{cp})$$

where

$$f_{cv} = 0.17 \left(1 + \frac{2}{\beta_h} \right) \sqrt{f'_c} \leq 0.34 \sqrt{f'_c}; \text{ or}$$

- (b) where there is a shear head—

$$V_{uo} = u d_{om} (0.5\sqrt{f'_c} + 0.3\sigma_{cp}) \leq 0.2 u d_{om} f'_c$$

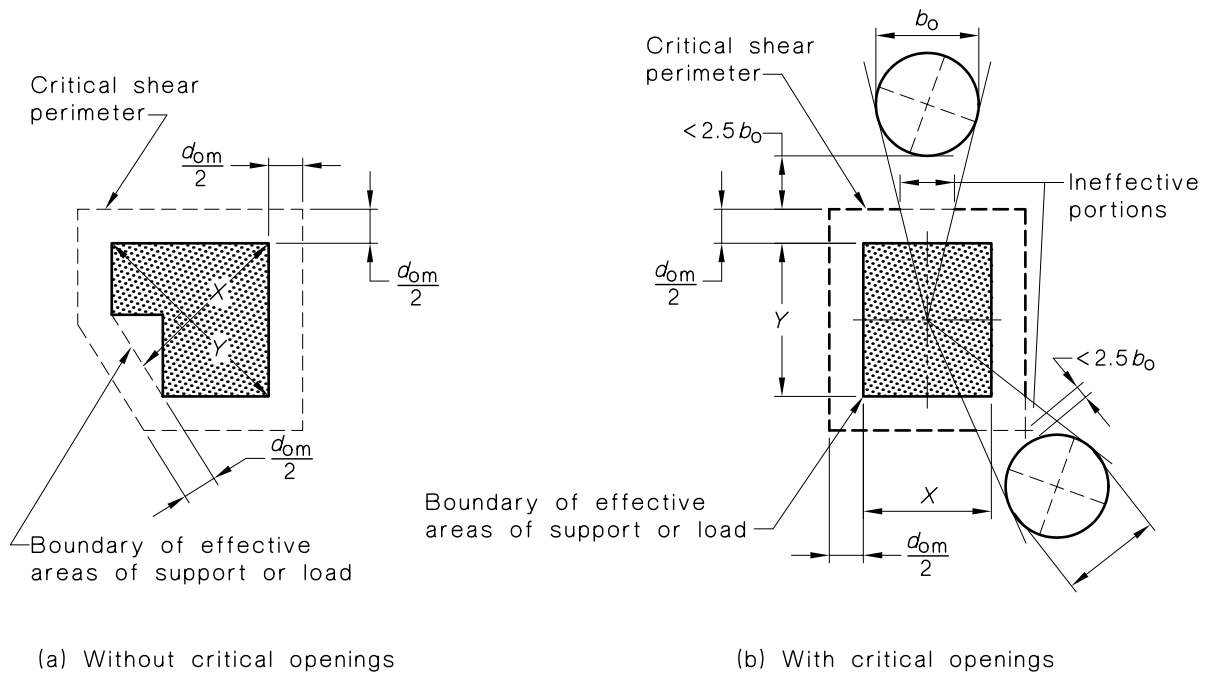

FIGURE 9.2.1(A) CRITICAL SHEAR PERIMETER

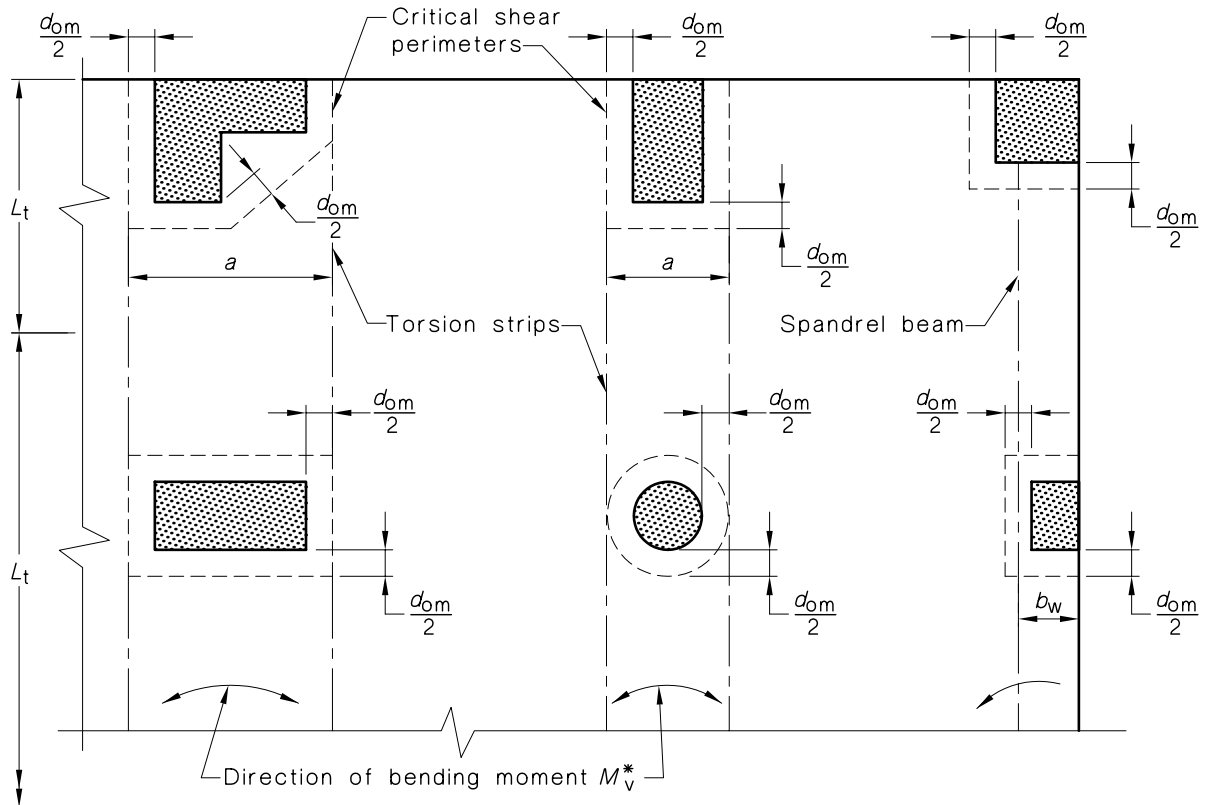

FIGURE 9.2.1(B) TORSION STRIPS AND SPANDREL BEAMS

9.2.4 Ultimate shear strength where M_v^* is not zero

Where M_v^* is not zero and shear reinforcement, if provided, complies with Clauses 9.2.5 and 9.2.6, then V_u shall be determined from one of the following:

- (a) If there are no closed ties in the torsion strip or spandrel beams, V_u is given by—

$$V_u = V_{uo} / [1.0 + (uM_v^* / 8V^* a d_{om})]$$
- (b) If the torsion strip contains the minimum quantity of closed ties, V_u shall be taken as $V_{u,min.}$ given by—

$$V_{u,min.} = 1.2V_{uo} / [1.0 + (uM_v^* / 2V^* a^2)]$$

- (c) If there are spandrel beams perpendicular to the direction of M_v^* which contain the minimum quantity of closed ties, V_u shall be taken as $V_{u,min.}$ given by—

$$V_{u,min.} = 1.2V_{uo} (D_b / D_s) [1.0 + (uM_v^* / 2V^* a b_w)]$$

- (d) If the torsion strip or spandrel beam, contains more than the minimum quantity of closed ties, V_u is given by—

$$V_u = V_{u,min.} \sqrt{[(A_{sw} / s) / (0.2 y_1 / f_{sy,f})]}$$

where $V_{u,min.}$ is calculated in accordance with Item (b) or (c), as appropriate.

In no case shall V_u be taken greater than $V_{u,max.}$ given by—

$$V_{u,max.} = 3V_{u,min.} \sqrt{(x / y)}$$

where x and y are the shorter and longer dimensions respectively of the cross-section of the torsion strip or spandrel beam.

9.2.5 Minimum area of closed ties

The minimum cross-sectional area of the reinforcement forming the closed ties shall satisfy the following inequality:

$$A_{sw} / s \geq 0.2y_1 / f_{sy.f}$$

9.2.6 Detailing of shear reinforcement

Reinforcement for slab shear in torsion strips and spandrel beams shall be in the form of closed ties arranged and detailed in accordance with the following:

- The ties shall extend along the torsion strip or spandrel beam for a distance not less than $L_v/4$ from the face of the support or concentrated load, on one or both sides of the centroid axis, as applicable. The first tie shall be located at not more than $0.5s$ from the face of the support.
- The spacing (s) of the ties shall not exceed the greater of 300 mm and, D_b or D_s , as applicable.
- At least one longitudinal bar shall be provided at each corner of the tie.
- The dimensions of the ties are as shown in Figure 9.2.6.

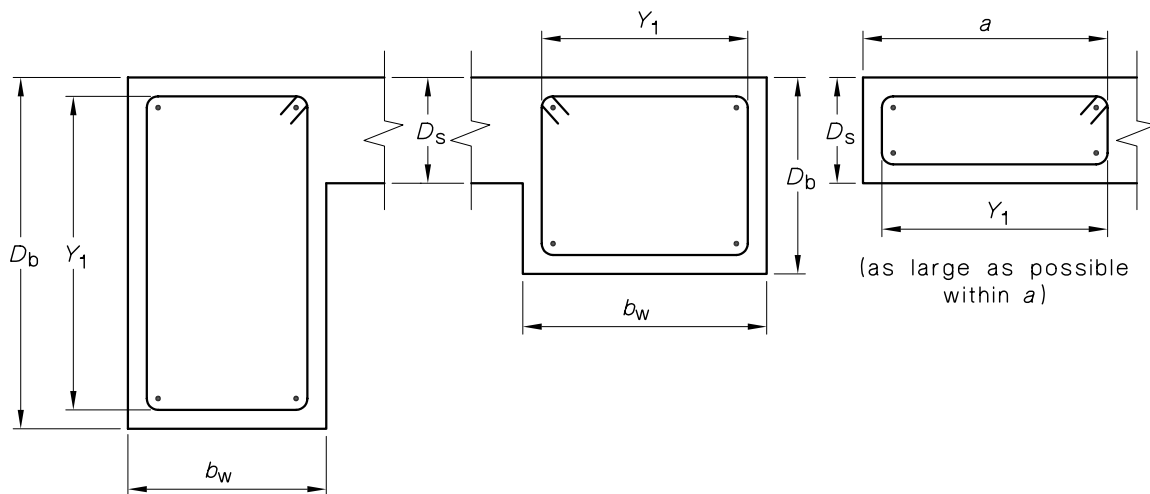

FIGURE 9.2.6 PARAMETERS AND DETAILS OF SHEAR REINFORCEMENT FOR SLABS

9.3 DEFLECTION OF SLABS

9.3.1 General

The deflection of a slab shall be determined in accordance with Clause 9.3.2 or Clause 9.3.3.

Alternatively, for reinforced slabs, the span-to-depth ratio of the slab shall comply with Clause 9.3.4.

9.3.2 Slab deflection by refined calculation

The calculation of the deflection of a slab by refined calculation shall make allowance for the following:

- Two-way action.
- Shrinkage and creep properties of the concrete.

- (c) Expected load history.
- (d) Cracking and tension stiffening.
- (e) Deflection of formwork or settlement of props during construction when the slab formwork is supported off suspended floors below.

9.3.3 Slab deflection by simplified calculation

The deflection of a slab subject to uniformly distributed loads shall be calculated in accordance with Clause 8.5.3 on the basis of an equivalent beam taken as follows:

- (a) For a one-way slab, a prismatic beam of unit width.
- (b) For a rectangular slab supported on four sides, a prismatic beam of unit width through the centre of the slab, spanning in the short direction L_x , with the same conditions of continuity as the slab in that direction and with the load distributed so that the proportion of load carried by the beam is given by—

$$L_y^4 / (\alpha L_x^4 + L_y^4)$$

where α is given in Table 9.3.3 for the appropriate slab-edge condition.

- (c) For a two-way flat slab having multiple spans (for deflections along the centreline of the supports), the design strips of the idealized frame described in Clause 7.5.2.

TABLE 9.3.3
COEFFICIENT OF PROPORTIONALITY (α)

Edge condition	Coefficient (α)
1 Four edges continuous	1.0
2 One short edge discontinuous	0.5
3 One long edge discontinuous	2.0
4 Two short edges discontinuous	0.2
5 Two long edges discontinuous	5.0
6 Two adjacent edges discontinuous	1.0
7 Three edges discontinuous (one long edge continuous)	0.4
8 Three edges discontinuous (one short edge continuous)	2.5
9 Four edges discontinuous	1.0

9.3.4 Deemed to comply span-to-depth ratio for reinforced slabs

9.3.4.1 One-way slabs and two-way flat slabs

For a reinforced one-way slab, or a multiple-span reinforced two-way flat slab of essentially uniform depth, fully propped during construction, subject to uniformly distributed loads and where the live load (q) does not exceed the dead load (g), slab deflections shall be deemed to comply with the requirements of Clause 2.4.2 if the ratio of the effective span to the effective depth is not greater than the value given by—

$$A1 \quad L_{ef} / d = k_3 k_4 \left[\frac{(\Delta / L_{ef}) E_c}{F_{d,ef}} \right]^{1/3}$$

where

- Δ/L_{ef} = the deflection limit selected in accordance with Clause 2.4.2 and the deflection (Δ) is taken on the centre-line between the supports used to calculate L_{ef}
- L_{ef} = the effective span
- $F_{\text{d,ef}}$ = the effective design load, per unit area, taken as—
- (a) $(1.0 + k_{\text{cs}})g + (\psi_{\text{s}} + k_{\text{cs}}\psi_{\text{l}})q$, for total deflection; or
 - (b) $k_{\text{cs}} g + (\psi_{\text{s}} + k_{\text{cs}}\psi_{\text{l}})q$, for the deflection that occurs after the addition or attachment of the partitions

where

k_{cs} is determined in accordance with Clause 8.5.3.3 and ψ_{s} and ψ_{l} are given in AS 1170.1

- k_3 = 1.0 for a one-way slab
- = 0.95 for a two-way flat slab without drop panels
- = 1.05 for a two-way flat slab with drop panels, which extend at least $L/6$ in each direction on each side of a support centre-line and have an overall depth not less than $1.3 D$, where D is the slab thickness beyond the drops
- k_4 = the deflection constant, which may be taken as—
- (a) for simply supported slabs, 1.6; or
 - (b) for continuous slabs, where in adjoining spans the ratio of the longer span to the shorter span does not exceed 1.2 and where no end span is longer than an interior span—
 - (i) 2.0 in an end span; or
 - (ii) 2.4 in interior spans

9.3.4.2 Rectangular slabs supported on four sides

For a reinforced concrete slab, supported on four sides by walls or beams, subject to uniformly distributed loads and where the live load (q) does not exceed the dead load (g) the slab deflection shall be deemed to comply with the requirements of Clause 2.4.2 if the ratio of the shorter effective span to the effective depth satisfies the requirements given in Clause 9.3.4.1, except that—

- (a) k_3 shall be taken as 1.0; and
- (b) the appropriate value of k_4 shall be taken from Table 9.3.4.2.

TABLE 9.3.4.2
SLAB-SYSTEM MULTIPLIER (k_4) FOR RECTANGULAR SLABS
SUPPORTED ON FOUR SIDES

Edge condition	Deflection constant (k_4)			
	Ratio of long to short side (L_y/L_x)			
	1.0	1.25	1.5	2.0
1 Four edges continuous	4.00	3.40	3.10	2.75
2 One short edge discontinuous	3.75	3.25	3.00	2.70
3 One long edge discontinuous	3.75	2.95	2.65	2.30
4 Two short edges discontinuous	3.55	3.15	2.90	2.65
5 Two long edges discontinuous	3.55	2.75	2.25	1.80
6 Two adjacent edges discontinuous	3.25	2.75	2.50	2.20
7 Three edges discontinuous (one long edge continuous)	3.00	2.55	2.40	2.15
8 Three edges discontinuous (one short edge continuous)	3.00	2.35	2.10	1.75
9 Four edges discontinuous	2.50	2.10	1.90	1.70

9.4 CRACK CONTROL OF SLABS

9.4.1 Crack control for flexure in reinforced slabs

For the purpose of this Clause the following apply:

- (a) A critical tensile zone is defined as a region of a slab where the design bending moment at the serviceability limit state ($M_{s,1}^*$) calculated with short-term load factor $\psi_s = 1.0$ (see Note 1), equals or exceeds the critical moment for flexural cracking (M_{crit}), which is calculated assuming a flexural tensile strength of concrete equal to 3.0 MPa.
- (b) In cases when the main reinforcement has different yield strengths, the yield strength (f_{sy}) shall be taken as the lowest yield strength of any of the reinforcement.

Cracking in reinforced slabs subject to flexure shall be deemed to be controlled if the appropriate requirements in Items (i), (ii), (iii), (iv) and (v) are satisfied. For areas of slabs fully enclosed within a building except for a brief period of weather exposure during construction and, where it is assessed that wider cracks can be tolerated, only Item (i) and Item (iii) need be satisfied.

- (i) The minimum area of reinforcement in a tensile zone of a slab shall comply with Clause 9.1.1.
- (ii) In a critical tensile zone, the minimum area of reinforcement ($A_{st,min.}$) shall not be less than—

$$A_{st,min.} = 3k_s A_{ct} / f_s$$

where

k_s = a coefficient that takes into account the shape of the stress distribution within the section immediately prior to cracking, as well as the effect of non-uniform self-equilibrating stresses, and equals 0.6

A_{ct} = the area of concrete in the tensile zone, being that part of the section in tension assuming the section is uncracked

f_s = the maximum tensile stress permitted in the reinforcement immediately after formation of a crack, which shall be the lesser of the yield strength of the reinforcement (f_{sy}) and the maximum steel stress given in Table 9.4.1(A) for the largest nominal diameter (d_b) of the bars in the section.

- (iii) The centre-to-centre spacing of bars in each direction shall not exceed the lesser of $2.0D_s$ or 300 mm. Bars with a diameter less than half the diameter of the largest bar in the cross-section shall be ignored.
- (iv) The calculated steel stress (f_{scr}) shall not exceed the maximum steel stress given in Table 9.4.1(A) for the largest nominal diameter (d_b) of the bars in the tensile zone. Alternatively, the calculated steel stress (f_{scr}) shall not exceed the maximum steel stress determined from Table 9.4.1(B) for the largest centre-to-centre spacing of adjacent parallel bars in the tensile zone (see Note 2). Bars with a diameter less than half the diameter of the largest bar in the section shall be ignored when determining spacing.
- (v) The calculated steel stress $f_{scr,1}$ shall not exceed $0.8f_{sy}$.

NOTES:

- Design bending moments M_s^* and $M_{s,1}^*$ at the serviceability limit state will normally be estimated using elastic analysis. Inaccurate estimates may be obtained if they are determined from the design bending moments M^* at the strength limit state when the amount of moment redistribution is unknown; for example, if plastic methods of analysis are used for strength design.
- If comparing the calculated steel stress (f_{scr}) with the maximum steel stresses determined from Tables 9.4.1(A) and 9.4.1(B) depending on the bar diameter and bar spacing, respectively, the greater of these two maximum steel stresses may be used.

TABLE 9.4.1(A)
MAXIMUM STEEL STRESS FOR FLEXURE IN SLABS

Nominal bar diameter (d_b) mm	Maximum steel stress (MPa) for overall depth, D_s (mm) of:	
	≤ 300	> 300
6	375	450
8	345	400
10	320	360
12	300	330
16	265	280
20	240	
24	210	

NOTE: Values for other bar diameters may be calculated using the appropriate equation, as follows:

Maximum steel stress equals

$$-173 \log_e (d_b) + 760 \text{ MPa for } d_b \geq 20 \text{ mm}$$

$$-173 \log_e (d_b) + 760 \text{ MPa for } d_b < 20 \text{ mm and } D_s > 300 \text{ mm}$$

$$-114 \log_e (d_b) + 580 \text{ MPa for } d_b < 20 \text{ mm and } D_s \leq 300 \text{ mm}$$

TABLE 9.4.1(B)
MAXIMUM STEEL STRESS FOR FLEXURE IN SLABS

Centre-to-centre spacing (mm)	Maximum steel stress (MPa)
50	360
100	320
150	280
200	240
250	200
300	160

NOTE: Intermediate values may be calculated using the equation:

$$\text{Maximum steel stress} = -0.8 \times \text{centre-to-centre spacing} + 400 \text{ MPa}$$

9.4.2 Crack control for flexure in prestressed slabs

Flexural cracking in a prestressed slab shall be deemed to be controlled if under the short-term service loads, the resulting maximum tensile stress in the concrete does not exceed $0.25\sqrt{f'_c}$ or, if this stress is exceeded, by providing reinforcement or bonded tendons near the tensile face and limiting—

- (a) either the calculated maximum flexural tensile stress in the concrete under short-term service load to $0.5\sqrt{f'_c}$; or
- (b) both—
 - (i) the increment in steel stress near the tension face to 150 MPa as the load increases from its value when the extreme concrete tensile fibre is at zero stress to the short-term service load value; and
 - (ii) the centre-to-centre spacing of reinforcement, including bonded tendons, to 500 mm.

9.4.3 Crack control for shrinkage and temperature effects

9.4.3.1 General

The area of reinforcement required to control cracking due to shrinkage and temperature effects shall take into account the influence of flexural action, the degree of restraint against in-plane movements and the exposure classification, in accordance with Clauses 9.4.3.2 to 9.4.3.5.

For members greater than 500 mm thick, the reinforcement required near each surface may be calculated using 250 mm for D .

9.4.3.2 Reinforcement in the primary direction

No additional reinforcement is required to control expansion or contraction cracking if the area of reinforcement in the direction of the span of a one-way slab, or in each direction of a two-way slab, is not less than—

- (a) the area required by Clause 9.1.1; and
- (b) 75% of the area required by one of Clauses 9.4.3.3 to 9.4.3.5, as appropriate.

9.4.3.3 Reinforcement in the secondary direction in unrestrained slabs

Where the slab is free to expand or contract in the secondary direction, the minimum area of reinforcement in that direction shall be $(1.75-2.5 \sigma_{cp}) bD \times 10^{-3}$. This requirement may be waived if the width of the slab in the secondary direction is less than 2.5 m.

9.4.3.4 Reinforcement in the secondary direction in restrained slabs

Where a slab is restrained from expanding or contracting in the secondary direction, the area of reinforcement in that direction shall be not less than the following, as appropriate:

- (a) For a slab fully enclosed within a building except for a brief period of weather exposure during construction—
- (i) where a minor degree of control over cracking is required $(1.75 - 2.5\sigma_{cp})bD \times 10^{-3}$;
 - (ii) where a moderate degree of control over cracking is required $(3.5 - 2.5\sigma_{cp})bD \times 10^{-3}$; and
 - (iii) where a strong degree of control over cracking is required $(6.0 - 2.5\sigma_{cp})bD \times 10^{-3}$.
- (b) For all other surface and exposure environments in classification A1 and for exposure classification A2 —
- (i) where a moderate degree of control over cracking is required, $(3.5 - 2.5\sigma_{cp})bD \times 10^{-3}$;
 - (ii) where a strong degree of control over cracking is required, $(6.0 - 2.5\sigma_{cp})bD \times 10^{-3}$.
- (c) For exposure classifications B1, B2 and C $(6.0 - 2.5\sigma_{cp})bD \times 10^{-3}$.

9.4.3.5 Reinforcement in the secondary direction in partially restrained slabs

Where a slab is partially restrained from expanding or contracting in the secondary direction, the minimum area of reinforcement in that direction shall be assessed taking into account the requirements of Clauses 9.4.3.3 and 9.4.3.4.

9.4.4 Crack control in the vicinity of restraints

In the vicinity of restraints, special attention shall be paid to the internal forces and cracks that may be induced by prestressing, shrinkage or temperature.

9.4.5 Crack control at openings and discontinuities

For crack control at openings and discontinuities in a slab, additional properly anchored reinforcement shall be provided if necessary.

9.5 VIBRATION OF SLABS

Vibration in slabs shall be considered and appropriate action taken, where necessary, to ensure that vibrations induced by machinery or vehicular and pedestrian traffic will not adversely affect the serviceability of the structure.

9.6 MOMENT RESISTING WIDTH FOR ONE-WAY SLABS SUPPORTING CONCENTRATED LOADS

The width of a solid one-way simply supported or continuous slab deemed to resist the moments caused by a concentrated load, may be taken as follows:

- (a) Where the load is not near an unsupported edge:

$$b_{ef} = \text{the load width} + 2.4a(1.0 - (a/L_n))$$

where

a = the perpendicular distance from the nearer support to the section under consideration

- (b) Where the load is near an unsupported edge, not greater than the lesser of—
- (i) the value given in Item (a) above; and
 - (ii) half the value given in Item (a) above plus the distance from the centre of the load to the unsupported edge.

9.7 LONGITUDINAL SHEAR IN COMPOSITE SLABS

Composite slab systems shall be checked for longitudinal shear at the interfaces between components in accordance with Clause 8.4.

SECTION 10 DESIGN OF COLUMNS FOR STRENGTH AND SERVICEABILITY

10.1 GENERAL

10.1.1 Design strength

The design strength of a column shall be determined by its ability to resist the axial forces and bending moments caused by the design loading for strength and any additional bending moments produced by slenderness effects.

10.1.2 Minimum bending moment

At any cross-section of a column, the design bending moment about each principal axis shall be taken to be not less than N^* times $0.05D$, where D is the overall depth of the column in the plane of the bending moment.

10.1.3 Definitions

For the purpose of this Section the following definitions apply:

10.1.3.1 Braced columns

Members for which the lateral load on the structure in the direction under consideration is resisted by masonry infill panels, shear walls or lateral bracing.

10.1.3.2 Short columns

Columns in which the additional bending moments due to slenderness can be taken as zero.

10.1.3.3 Slender columns

Columns that do not satisfy the requirements for short columns.

10.2 DESIGN PROCEDURES

10.2.1 Design procedure using linear elastic analysis

Where the axial forces and bending moments are determined by a linear elastic analysis as provided in Clause 7.6, a column shall be designed as follows:

- (a) For a short column, in accordance with Clauses 10.3, 10.6 and 10.7.
- (b) For a slender column, in accordance with Clauses 10.4 to 10.7.

10.2.2 Design procedure, incorporating secondary bending moments

Where the axial forces and bending moments are determined by an elastic analysis incorporating secondary bending moments due to lateral joint displacements, as provided in Clause 7.7, a column shall be designed in accordance with Clauses 10.6 and 10.7. The bending moments in slender columns shall be further increased by applying the moment magnifier for a braced column (δ_b) calculated in accordance with Clause 10.4.2 with L_e taken as L_u in the determination of N_c .

10.2.3 Design procedure, using rigorous analysis

Where the axial forces and bending moments are determined by a rigorous analysis, as provided in Clause 7.8, a column shall be designed in accordance with Clauses 10.6 and 10.7 without further consideration of additional moments due to slenderness.

10.3 DESIGN OF SHORT COLUMNS

10.3.1 General

Short columns shall be designed in accordance with Clauses 10.6 and 10.7, with additional bending moments due to slenderness taken to be zero. Alternatively, for short columns with small axial forces or small bending moments, the design may be in accordance with Clauses 10.3.2 and 10.3.3 respectively.

A column shall be deemed to be short where—

- (a) for a braced column—

$$L_e / r \leq 25; \text{ or}$$

$$\leq 60 \left(1 + M^*_1 / M^*_2 \right) \left(1.0 - N^* / 0.6 N_{uo} \right)$$

whichever is the greater; or

- (b) for an unbraced column—

$$L_e / r \leq 22$$

Where, for Items (a) and (b) above—

r = the radius of gyration of the cross-sections determined in accordance with Clause 10.5.2

M^*_1 / M^*_2 = the ratio of the smaller to the larger of the design bending moments at the ends of the column. The ratio is taken to be negative when the column is bent in single curvature and positive when the column is bent in double curvature. When the absolute value of M^*_2 is less than or equal to $0.05DN^*$, the ratio shall be taken as -1.0 .

L_e = the effective length determined in accordance with Clause 10.5; or alternatively may be taken as—

- (i) for a braced column restrained by a flat slab floor, L_u ;
- (ii) for a braced column restrained by beams, $0.9L_u$; and
- (iii) for a column designed in accordance with Clause 10.2.2, L_u

10.3.2 Short column with small compressive axial force

Where the design compressive axial force (N^*) in a short column is less than $0.1 f'_c A_g$, the cross-section may be designed for bending only.

10.3.3 Short braced column with small bending moments

The bending moments in a short interior column of a braced rectangular framed building structure may be disregarded if—

- (a) the ratio of the longer to the shorter length of any two adjacent spans does not exceed 1.2;
- (b) the loads are essentially uniformly distributed;
- (c) the live load (q) does not exceed twice the dead load (g);
- (d) members are of uniform cross-section; and
- (e) the cross-section of the column is symmetrically reinforced,

in which case the design axial strength (ϕN_u) is taken as not greater than $0.75 \phi N_{uo}$, where N_{uo} is determined in accordance with Clause 10.6.3.

10.4 DESIGN OF SLENDER COLUMNS

10.4.1 General

Slender columns shall be designed in accordance with Clauses 10.6 and 10.7, with additional bending moments due to slenderness effects taken into account by multiplying the largest design bending moment by the moment magnifier (δ).

The moment magnifier (δ) shall be calculated in accordance with Clause 10.4.2 for a braced column and Clause 10.4.3 for an unbraced column.

For columns subject to bending about both principal axes, the bending moment about each axis shall be magnified by δ , using the restraint conditions applicable to each plane of bending.

The additional end moments calculated from moment magnification may be distributed to the members of the joint in proportion to their stiffness.

10.4.2 Moment magnifier for a braced column

The moment magnifier (δ) for a braced column, shall be taken to be equal to δ_b given by—

$$\delta_b = k_m / (1 - N^* / N_c) \geq 1$$

where

N_c = the buckling load given in Clause 10.4.4

k_m = $(0.6 - 0.4 M_1^* / M_2^*)$ but shall be taken as not less than 0.4, except that if the column is subjected to significant transverse loading between its ends and in the absence of more exact calculations, k_m shall be taken as 1.0

10.4.3 Moment magnifier for an unbraced column

The moment magnifier (δ) for an unbraced column shall be taken as the larger value of δ_b or δ_s where—

- (a) δ_b for an individual column is calculated in accordance with Clause 10.4.2 assuming the column is braced; and
- (b) δ_s for each column in the storey is calculated as

$$1 / (1 - \sum N^* / \sum N_c)$$

where the summations include all columns within the storey and N_c is calculated for each column in accordance with Clause 10.4.4.

As an alternative to Item (b), δ_s may be calculated from a linear elastic critical buckling load analysis of the entire frame, where δ_s is taken as a constant value for all columns given by—

$$\delta_s = 1 / [1 - (1 + \beta_d) / (\phi_s \lambda_{uc})]$$

where

β_d = $G / (G + Q)$ taken as zero when $L_c / r \leq 40$ and $N^* \leq M^* / 2D$, and G and Q are the design axial load components due to dead load and live load respectively

ϕ_s = a correlation factor taken as 0.6.

λ_{uc} = the ratio of the elastic critical buckling load of the entire frame to the design load for strength, calculated by taking the cross-sectional stiffness of the flexural members and columns as $0.4E_c I_f$ and $0.8E_c I_c$ respectively.

The frame shall be proportioned so that δ_s for any column is not greater than 1.5.

10.4.4 Buckling load

The buckling load, N_c , shall be taken as—

$$N_c = \left(\pi^2 / L_e^2 \right) \left[182 d_o (\phi M_{ub}) / (1 + \beta_d) \right]$$

where

ϕM_{ub} = the design strength in bending of the cross-section when $k_{uo} = 0.545$ and $\phi = 0.6$.

10.5 SLENDERNESS

10.5.1 General

The slenderness ratio (L_e/r) of a column shall not exceed 120, unless a rigorous analysis has been carried out in accordance with Clause 7.8 and the column is designed in accordance with Clause 10.2.3.

Where the forces and moments acting on a column have been obtained from a linear elastic analysis, as specified in Clause 7.6, the influence of slenderness shall be taken into account using a radius of gyration (r) specified in Clause 10.5.2 and an effective length (L_e), in accordance with Clause 10.5.3.

10.5.2 Radius of gyration

The radius of gyration (r) shall be calculated for the gross concrete cross-section. For a rectangular cross-section, r may be taken as $0.3D$, where D is the overall dimension in the direction in which stability is being considered and for a circular cross-section, r may be taken as $0.25D$.

10.5.3 Effective length of a column

The effective length of a column (L_e) shall be taken as kL_u where the effective length factor, k , is determined from Figure 10.5.3(A) for columns with simple end restraints, or more generally from Figure 10.5.3(B) or 10.5.3(C), as appropriate.

The end restraint coefficients (γ_1 and γ_2) shall be determined—

- for regular rectangular framed structures where the axial forces in the beams are generally small, in accordance with Clause 10.5.4;
- for all structures, including non-rectangular framed structures or structures where the axial forces in the restraining members are large, in accordance with Clause 10.5.5; and
- where the column ends at a footing, in accordance with Clause 10.5.6.

Alternatively, the effective length of a column may be determined from the elastic critical buckling load of the frame, as calculated by analysis.

10.5.4 End restraint coefficients for regular rectangular framed structures

For regular rectangular framed structures, the end restraint coefficient (γ_1) at one end of a column and the end restraint coefficient (γ_2) at the other end may each be calculated as—

$$\frac{\sum (I/L)_c}{\sum (\beta I/L)_b}$$

where

$\Sigma(I/L)_c$ = the sum of the stiffness in the plane of bending of all the columns meeting at and rigidly connected to the end of the column under consideration

$\Sigma(\beta I/L)_b$ = the sum of the stiffness in the plane of bending of all the beams or slabs, or both, meeting at and rigidly connected to the same end of the column under consideration

β = a fixity factor, given in Table 10.5.4, for fixity conditions at the end of each beam or slab, or both, opposite to the end connected to the column under consideration

TABLE 10.5.4
FIXITY FACTOR (β)

Fixity conditions at far end of a beam or slab, or both	Fixity factor (β)	
	Beam or slab or both, in a braced frame	Beam or slab or both in an unbraced frame
Pinned	1.5	0.5
Rigidly connected to a column	1.0	1.0
Fixed	2.0	0.67

	Braced column			Unbraced column		
Buckled shape						
Effective length factor (k)	0.70	0.85	1.00	1.20	2.20	2.20
Symbols for end restraint conditions	= Rotation fixed, translation fixed = Rotation free, translation fixed			= Rotation fixed, translation free = Rotation free, translation free		

FIGURE 10.5.3(A) EFFECTIVE LENGTH FACTORS (k) FOR COLUMNS WITH SIMPLE END RESTRAINTS

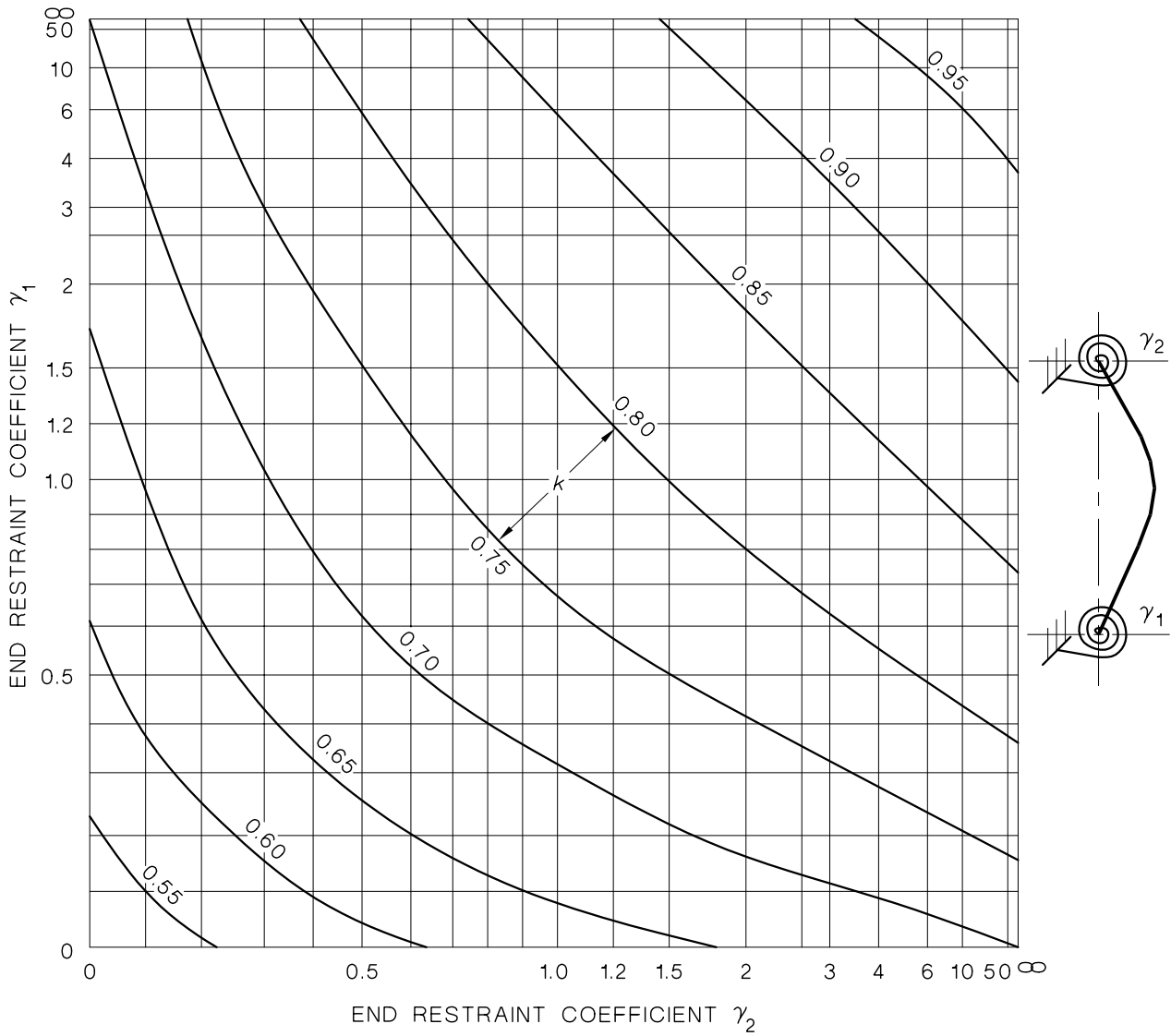

FIGURE 10.5.3(B) EFFECTIVE LENGTH FACTOR (k) FOR A BRACED COLUMN

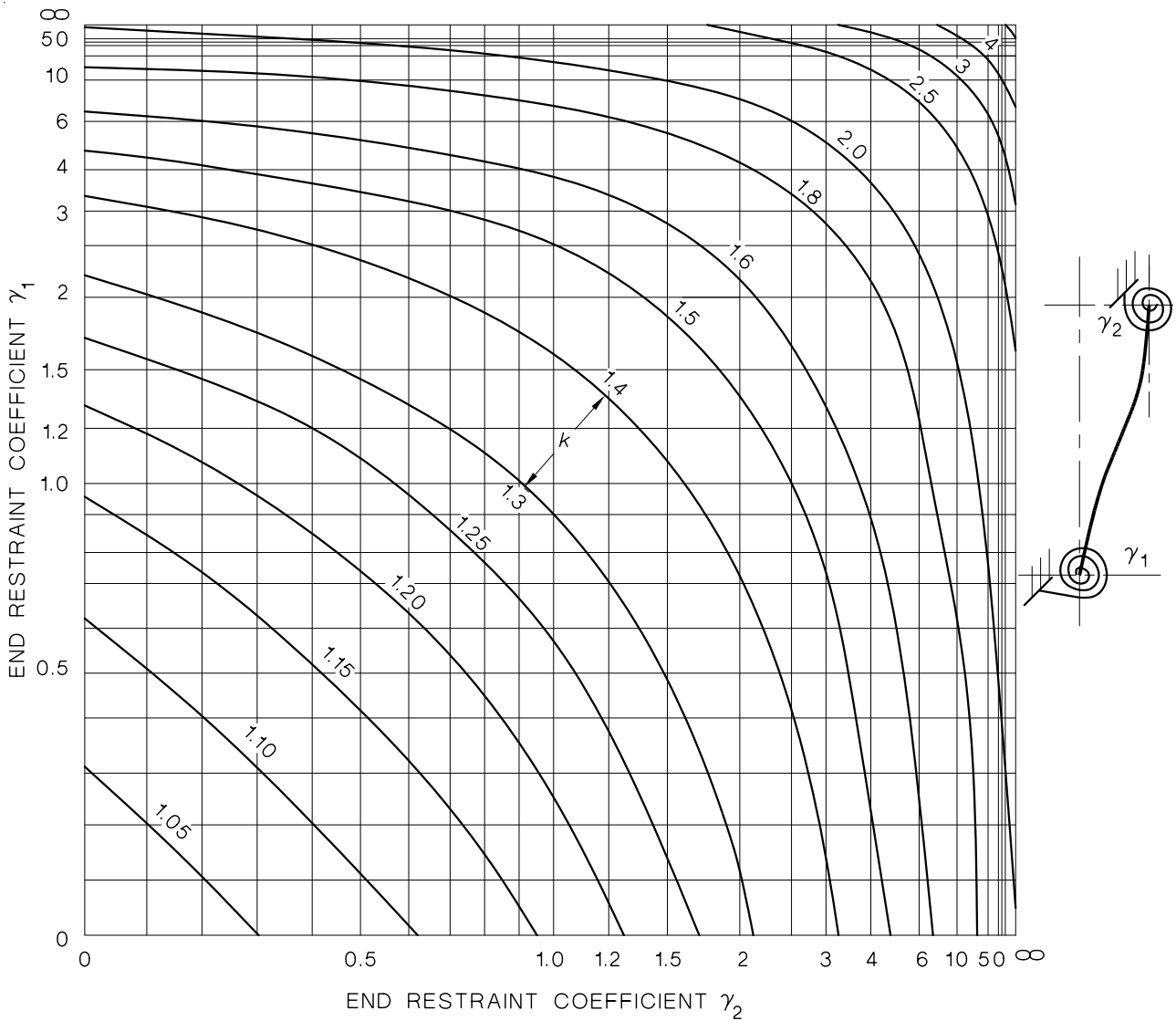

FIGURE 10.5.3(C) EFFECTIVE LENGTH FACTOR (k) FOR AN UNBRACED COLUMN

10.5.5 End restraint coefficients for any framed structure

For any framed structure, the end restraint coefficient (γ_1) at one end of a column and the end restraint coefficient (γ_2) at the other end may be calculated as the ratio of the column stiffness to the sum of the stiffness of all the members, except the column, meeting at the end under consideration. In the calculation of the stiffness of the members other than the column, due account shall be taken of the fixity conditions of each member at the end remote from the column-end being considered as well as any reduction in member stiffness due to axial compression.

10.5.6 End restraint provided by footings

Where a footing provides negligible restraint to the rotation of the end of a column, γ is theoretically infinite but may be taken as 10.

Where a footing is specifically designed to prevent rotation of the end of a column, γ is theoretically zero but shall be taken as one unless analysis would justify a smaller value.

10.6 STRENGTH OF COLUMNS IN COMBINED BENDING AND COMPRESSION

10.6.1 Basis of strength calculations

Calculations for the strength of cross-sections in bending, combined with axial forces, shall incorporate equilibrium and strain-compatibility considerations and be consistent with the following assumptions:

- Plane sections normal to the axis remain plane after bending.
- The concrete has no tensile strength.
- The distribution of stress in the concrete and the steel is determined using a stress-strain relationship determined from Clauses 6.1.4 and 6.2.3 respectively (see Note).
- The strain in compressive reinforcement does not exceed 0.003.

Columns subject to axial force with bending moments about each principal axis may take into account the concessions given in Clauses 10.6.4 and 10.6.5.

NOTE: If a curvilinear stress-strain relationship is used, Clause 6.1.4 places a limit on the value of the maximum concrete stress.

10.6.2 Rectangular stress block

Where the neutral axis lies within the cross-section and provided that the maximum strain in the extreme compression fibre of the concrete is taken as 0.003, Clause 10.6.1(c) shall be deemed to be satisfied for the concrete by assuming that a uniform concrete compressive stress of $0.85 f'_c$ acts on an area bounded by—

- the edges of the cross-section; and
- a line parallel to the neutral axis under the loading concerned, and located at a distance $\gamma k_u d$ from the extreme compressive fibre where—

$$\gamma = [0.85 - 0.007(f'_c - 28)] \text{ with the limits } 0.65 \text{ to } 0.85.$$

NOTE: The modification given in Clause 6.1.4 is included in the rectangular stress block assumptions.

10.6.3 Calculation of N_{uo}

The ultimate strength in compression (N_{uo}) shall be calculated by assuming—

- a uniform concrete compressive stress of $0.85 f'_c$; and
- a maximum strain in the steel and the concrete of 0.0025.

10.6.4 Design based on each bending moment acting separately

For a rectangular cross-section, where the ratio of the larger to the smaller cross-sectional dimension does not exceed 3.0, which is subjected simultaneously to an axial force and bending moments about each principal axis, the cross-section may be designed for the axial force with each bending moment considered separately, provided that the line of action of the resultant axial force falls within the shaded area of the cross-section shown in Figure 10.6.4.

A1

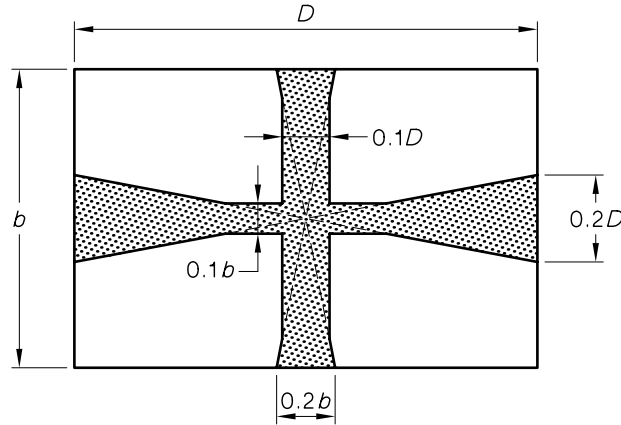

Shaded areas symmetrical about column centrelines

FIGURE 10.6.4 LIMITATION FOR LINE OF ACTION OF THE RESULTANT AXIAL FORCE

10.6.5 Design for biaxial bending and compression

A rectangular cross-section, subject to axial force and bending moment acting simultaneously about each principal axis, may be designed such that—

$$\left(\frac{M_x^*}{\phi M_{ux}} \right)^{\alpha_n} + \left(\frac{M_y^*}{\phi M_{uy}} \right)^{\alpha_n} \leq 1.0$$

where

$\phi M_{ux}, \phi M_{uy}$ = the design strength in bending, calculated separately, about the major and minor axis respectively under the design axial force (N^*)

M_x^*, M_y^* = the design bending moment about the major and minor axis respectively, magnified if applicable

α_n = $0.7 + 1.7 N^*/0.6N_{uo}$, within the limits $1 \leq \alpha_n \leq 2$

10.7 REINFORCEMENT REQUIREMENTS FOR COLUMNS

10.7.1 Limitations on longitudinal steel

The cross-sectional area of the longitudinal reinforcement in a column shall—

- (a) be not less than $0.01A_g$ except that, in a column which has a larger area than that required for strength, a reduced value of A_{sc} may be used if $A_{sc}f_{sy} > 0.15N^*$; and
- (b) not exceed $0.04A_g$ unless the amount and disposition of the reinforcement will not prevent the proper placing and compaction of the concrete at splices and at junctions of the members.

10.7.2 Bundled bars

Groups of parallel longitudinal bars, which are bundled to act as a unit, shall have not more than 4 bars in any one bundle and be tied together in contact.

10.7.3 Restraint of longitudinal reinforcement

10.7.3.1 General requirements

The following longitudinal bars in columns shall be laterally restrained in accordance with Clause 10.7.3.2:

- (a) Single bars—
 - (i) each corner bar;
 - (ii) all bars, where bars are spaced at centres of more than 150 mm; and
 - (iii) at least every alternate bar, where bars are spaced at 150 mm or less.
- (b) Bundled bars, each bundle.

10.7.3.2 Lateral restraint

Lateral restraint shall be deemed to be provided if the longitudinal reinforcement is placed within and in contact with—

- (a) a non-circular tie—
 - (i) at a bend in the tie, where the bend has an included angle of 135° or less;
 - (ii) between two 135° fitment hooks; or
 - (iii) inside a single 135° fitment hook of a fitment, which is approximately perpendicular to the column face; or
- (b) a circular tie or helix and the longitudinal reinforcement are equally spaced around the circumference.

10.7.3.3 Diameter and spacing of ties and helices

The diameter and spacing of ties and helices shall comply with the following:

- (a) The bar diameter of the tie or helix shall be not less than that given in Table 10.7.3.3.

TABLE 10.7.3.3
BAR DIAMETERS FOR TIES AND HELICES

Longitudinal bar diameter mm	Minimum bar diameter of tie or helix mm
Single bars up to 20	6
Single bars 24 to 36	10
Bundled bars	12

- (b) The spacing of ties, or the pitch of a helix, shall not exceed the smaller of—
 - (i) D_c and $15d_b$ for single bars; or
 - (ii) $0.5D_c$ and $7.5d_b$ for bundled bars,
 where

D_c = the smaller column dimension if rectangular or the column diameter if circular

d_b = the diameter of the smallest bar in the column

- (c) One tie, or the first turn of a helix, shall be located not more than 50 mm vertically above the top of a footing, or the top of a slab in any storey. Another tie, or the final turn of a helix, shall be located not more than 50 mm vertically below the soffit of the slab except that in a column with a capital, the tie or turn of the helix shall be located at a level at which the area of the cross-section of the capital is not less than twice that of the column.

Where beams or brackets frame from four directions into a column and adequately restrain the column in all directions, the ties or helix may be terminated 50 mm below the highest soffit of such beams or brackets.

- (d) Welded wire mesh, having strength and anchorage equivalent to that required for bars, may be used.

10.7.3.4 *Detailing of ties and helices*

Detailing of ties and helices shall be as follows:

- (a) A rectangular tie shall be spliced by welding, or by fixing two 135° fitment hooks around a bar or a bundle at a fitment corner. Internal ties may be spliced by lapping within the column core.
- (b) A circular shaped tie shall be spliced either by welding, or by overlapping and fixing two 135° fitment hooks around adjacent longitudinal bars or bundles.
- (c) A helix shall be anchored at its end by one-and-one-half extra turns of the helix. It may be spliced within its length either by welding, or by mechanical means.
- (d) Where hooks or cogs are specified in combination with bundled bars, the internal diameter of the bend shall be increased sufficiently to readily accommodate the bundle.

10.7.3.5 *Column joint reinforcement*

Where bending moments from a floor system are transferred to a column, lateral shear reinforcement, of area $A_{sv} \geq 0.35 bs/f_{sv,f}$, shall be provided through the joint unless restraint on all sides is provided by a floor system of approximately equal depth.

10.7.4 **Splicing of longitudinal reinforcement**

10.7.4.1 *General*

Longitudinal reinforcement in columns shall be spliced in accordance with Clauses 10.7.4.2 to 10.7.4.5 and the splices shall comply with Clause 13.2.

10.7.4.2 *Minimum tensile strength*

At any splice in a column, a tensile strength in each face of the column of not less than $0.25f_{sy}A_s$ shall be provided, where A_s is the cross-sectional area of longitudinal reinforcement in that face.

10.7.4.3 *Where tensile force exceeds the minimum tensile strength*

At any splice in a column where tensile stress exists and the tensile force in the longitudinal bars at any face of the column, due to strength design load effects, exceeds the minimum strength requirements given in Clause 10.7.4.2, the force in the bars shall be transmitted by—

- A1 | (a) a welded or mechanical splice; or
 | (b) a lap-splice in tension in accordance with Clause 13.2.2 or 13.2.5.

10.7.4.4 *End-bearing splice in compression*

Where the splice is always in compression, the force in the longitudinal bar may be transmitted by the bearing of square-cut mating ends held in concentric contact by a sleeve, provided that an additional tie, which complies with Clause 10.7.3, is placed above and below each sleeve. The bars shall be rotated to achieve the maximum possible area of contact between the ends of the bars and the requirements of Clause 10.7.4.2 shall be met.

10.7.4.5 *Offset bars*

Where a longitudinal bar is offset to form a lap splice—

- (a) the slope of the inclined part of the bar in relation to the axis shall not exceed 1 in 6;
- (b) the portions of the bar on either side of the offset shall be parallel; and
- (c) adequate lateral support shall be provided at the offset.

Where a column face is offset 75 mm or greater, longitudinal bars shall not be offset by bending but shall be lap-spliced with separate splicing bars placed adjacent to the offset column faces.

10.8 TRANSMISSION OF AXIAL FORCE THROUGH FLOOR SYSTEMS

The transmission of axial force through floor systems shall be designed for in accordance with the following:

- (a) Where the strength specified for the column concrete is greater than 1.4 times that specified for the floor system, proper transmission of force through the floor concrete shall be provided by adding vertical reinforcement, in accordance with calculations made on the basis of the lower concrete strength.
- (b) Notwithstanding the requirements of Item (a) above, where the ratio of specified strength for the columns to specified strength for the floor system does not exceed 2.0, proper transmission of force through the floor concrete shall be deemed to exist if—
 - (i) the column is restrained on four sides by beams of approximately equal depth, or by a slab;
 - (ii) the column is restrained on three sides by beams of approximately equal depth, or by a slab, and the unrestrained face is the shorter side of the column and the column has a ratio of long to short sides of not less than 3.0;
 - (iii) the column is restrained on three sides by beams of approximately equal depth, or by a slab, and the dimension of the column perpendicular to the unrestrained face is not less than twice the depth of the floor system; or
 - (iv) the column is restrained on two sides by beams of approximately equal depth, or by a slab, and the height of the column cast with concrete of the floor system is not greater than 0.25 times the least dimension of the column.

SECTION 11 DESIGN OF WALLS

11.1 APPLICATION

This Section applies to the design of planar walls.

11.2 DESIGN PROCEDURES**11.2.1 General**

Planar walls shall be designed in accordance with Clauses 11.2.2 to 11.2.6 if appropriate. The reinforcement provided shall comply with Clause 11.6.

11.2.2 Walls subject only to in-plane vertical forces

Walls subject only to in-plane vertical forces may be designed either —

- (a) in accordance with the simplified methods of Clause 11.4 if they are braced in accordance with Clause 11.3; or
- (b) as columns in accordance with Section 10 if vertical reinforcement is provided in each face, except that Clause 11.6.4 shall override the requirements of Clause 10.7.3.

11.2.3 Walls subject to in-plane vertical and horizontal forces

Walls subject to vertical and horizontal forces in the plane of the wall shall be designed for vertical action effects in accordance with Clause 11.2.2 and horizontal action effects in accordance with Clause 11.5.

11.2.4 Walls subject principally to horizontal forces perpendicular to the wall

Walls subject to horizontal forces perpendicular to the plane of the wall and for which the design vertical force (N^*) at mid-height does not exceed $0.03 f'_c A_g$, shall be designed as slabs in accordance with the appropriate clauses of Section 9 except that the ratio of effective height to thickness shall not exceed 50, where the effective height is determined from Clause 11.4.3.

11.2.5 Walls subject to in-plane vertical forces and horizontal forces perpendicular to the wall

Walls subject to in-plane vertical forces and horizontal forces perpendicular to the plane of the wall shall be designed as columns in accordance with Section 10, except that Clause 11.6.4 shall override the requirements of Clause 10.7.3.

11.2.6 Walls forming part of a framed structure

Walls subject to axial forces bending moments and shear forces arising from forces acting on the frame shall be designed in accordance with Sections 9 and 10 as appropriate.

11.3 BRACING OF WALLS

Walls shall be assumed to be braced if they are laterally supported by a structure in which all the following apply:

- (a) Walls or vertical braced elements are arranged in two directions so as to provide lateral stability to the structure as a whole.
- (b) Lateral forces are resisted by shear in the planes of these walls or by braced elements.
- (c) Floor and roof systems are designed to transfer lateral forces.

- (d) Connections between the wall and the lateral supports are designed to resist a horizontal force not less than—
- (i) the simple static reactions to the total applied horizontal forces at the level of lateral support; and
 - (ii) 2.5% of the total vertical load that the wall is designed to carry at the level of lateral support, but not less than 2 kN per metre length of wall.

11.4 SIMPLIFIED DESIGN METHOD FOR BRACED WALLS SUBJECT TO VERTICAL FORCES ONLY

11.4.1 Eccentricity of vertical load

The design of a wall shall take account of the actual eccentricity of the vertical force but in no case shall the design bending moment (M^*) be taken as less than N^* times $0.05t_w$.

The vertical load transmitted to a wall by a discontinuous concrete floor or roof shall be assumed to act at one-third the depth of the bearing area measured from the span face of the wall. Where there is an in situ concrete floor continuous over the wall, the load shall be assumed to act at the centre of the wall.

The resultant eccentricity of the total vertical load on a braced wall at any level between horizontal lateral supports, shall be calculated on the assumption that the resultant eccentricity of all the vertical loads above the upper support is zero.

11.4.2 Maximum effective height-to-thickness ratio

The ratio of effective height to thickness (H_{we}/t_w), shall not exceed 30, except that for walls in which the design axial force (N^*) at mid-height does not exceed $0.03f'_cA_g$, the ratio may be increased to 50.

11.4.3 Effective height

The effective height (H_{we}) of a braced wall shall be taken as follows:

- (a) Where restrained against rotation at both ends by—
 - (i) floors $0.75H_{wu}$; or
 - (ii) intersecting walls or similar members $0.75L_1$,
 whichever is the lesser.
- (b) Where not restrained against rotation at both ends by—
 - (i) floors $1.0H_{wu}$; or
 - (ii) intersecting walls or similar members $1.0L_1$,
 whichever is the lesser,

where in both Items (a) and (b)

H_{wu} = the unsupported height of the wall

L_1 = the horizontal distance between centres of lateral restraint

11.4.4 Design axial strength of a wall

The design axial strength per unit length of a braced wall in compression shall be taken as ϕN_u , where

$\phi = 0.6$; and

$$N_u = (t_w - 1.2e - 2e_a) 0.6f'_c$$

where

N_u = the ultimate strength per unit length of wall

t_w = the thickness of the wall

e = the eccentricity of the load measured at right angles to the plane of the wall, determined in accordance with Clause 11.4.1

e_a = an additional eccentricity taken as $(H_{we})^2/2500t_w$

11.5 DESIGN OF WALLS FOR IN-PLANE HORIZONTAL FORCES

11.5.1 In-plane bending

Where the in-plane horizontal forces, acting in conjunction with the axial forces, are such that on a horizontal cross-section there is—

- always compression over the entire section, in-plane bending may be neglected and the wall designed for horizontal shear only, in accordance with the remainder of this Section; or
- tension on part of the section, the wall shall be designed for in-plane bending in accordance with Section 8 and for horizontal shear in accordance with the remainder of this Section, or for in-plane bending and shear, in accordance with Section 12, if appropriate.

11.5.2 Critical section for shear

The critical section for maximum shear shall be taken at a distance from the base of $0.5L_w$ or $0.5H_w$, whichever is less.

11.5.3 Strength in shear

The design strength of a wall subject to in-plane shear shall be taken as ϕV_u

where

$$V_u = V_{uc} + V_{us}$$

and V_{uc} and V_{us} are determined from Clause 11.5.4 and Clause 11.5.5 respectively but in no case shall V_u be taken as greater than—

$$V_{u,max.} = 0.2f'_c (0.8L_w t_w)$$

11.5.4 Shear strength without shear reinforcement

The ultimate shear strength of a wall without shear reinforcement, V_{uc} , shall be taken as—

- where $H_w / L_w \leq 1$,

$$V_{uc} = (0.66\sqrt{f'_c} - 0.21\frac{H_w}{L_w}\sqrt{f'_c}) 0.8 L_w t_w; \text{ or}$$

- where $H_w/L_w > 1$, the lesser of the values calculated from Item (a) above and from—

$$V_{uc} = \left[0.05\sqrt{f'_c} + \frac{0.1\sqrt{f'_c}}{\left(\frac{H_w}{L_w} - 1\right)} \right] 0.8 L_w t_w$$

but in any case

$$V_{uc} \geq 0.17\sqrt{f'_c} (0.8L_w t_w)$$

11.5.5 Contribution to shear strength by shear reinforcement

The contribution to the ultimate shear strength of a wall by shear reinforcement (V_{us}) shall be determined from the following equation:

$$V_{us} = p_w f_{sy} (0.8 L_w t_w)$$

where p_w is determined as follows:

- (a) For walls where $H_w/L_w \leq 1$, p_w shall be the lesser of the ratios of either the vertical reinforcement area or the horizontal reinforcement area to the cross-sectional area of wall in the respective direction.
- (b) For walls where $H_w/L_w > 1$, p_w shall be ratio of the horizontal reinforcement area to the cross-sectional area of wall per vertical metre.

11.6 REINFORCEMENT REQUIREMENTS FOR WALLS

11.6.1 Minimum reinforcement

Walls shall have a reinforcement ratio (p_w)—

- (a) in the vertical direction, of not less than the larger of either 0.0015 or the value required by structural analysis; and
- (b) in the horizontal direction, of not less than 0.0025 except that where there is no restraint against horizontal shrinkage or thermal movements, this may be reduced to zero for walls less than 2.5 m overall in the horizontal direction, or to 0.0015 otherwise.

For walls greater than 500 mm thick, the minimum reinforcement required near each surface may be calculated using 250 mm for t_w .

11.6.2 Horizontal reinforcement for crack control

Where a wall is restrained from expanding or contracting horizontally due to shrinkage or temperature, the horizontal reinforcement ratio shall be not less than the following, as appropriate:

- (a) For exposure classifications A1 and A2—
 - (i) where a minor degree of control over cracking is required 0.0025;
 - (ii) where a moderate degree of control over cracking is required 0.0035;
 - (iii) where a strong degree of control over cracking is required 0.006.
- (b) For exposure classifications B1, B2 and C 0.006.

11.6.3 Spacing of reinforcement

The minimum clear distance between parallel bars, ducts and tendons shall be sufficient to ensure that the concrete can be placed and compacted to comply with Clause 19.1.3 but shall be not less than $3d_b$.

The maximum centre-to-centre spacing of parallel bars shall be $2.5t_w$ or 350 mm, whichever is the lesser.

For walls greater than 200 mm thick, the vertical and horizontal reinforcement shall be provided in two grids, one near each face of the wall.

11.6.4 Restraint of vertical reinforcement

For walls designed as columns in accordance with Section 10, the restraint provisions of Clause 10.7.3 do not apply if $N^* \leq 0.5 \phi N_u$.

SECTION 12 DESIGN OF NON-FLEXURAL MEMBERS, END ZONES AND BEARING SURFACES

12.1 DESIGN OF NON-FLEXURAL MEMBERS

12.1.1 General

12.1.1.1 Application

This Clause applies to the design of non-flexural members including deep beams, footings, pile caps, corbels, continuous nibs and stepped joints where the ratio of the clear span or projection to the overall depth is less than—

- (a) for cantilevers 1.5;
- (b) for simply supported members 3; and
- (c) for continuous members 4.

12.1.1.2 Design basis

The design strength of non-flexural members shall be calculated as ϕ times the ultimate strength, based on one of the following:

- (a) The general principles of concrete strut and steel tension tie action in accordance with Clause 12.1.2.
- (b) For deep beams, footings and pile caps stress analysis in accordance with Clause 12.1.3.
- (c) Empirical design methods in accordance with Clause 12.1.4.

12.1.1.3 Spacing of reinforcement

The minimum clear distance between parallel bars, (including bundled bars), ducts, or tendons shall be sufficient to ensure that the concrete can be placed and compacted to comply with Clause 19.1.3.

12.1.2 Design based on strut and tie action

12.1.2.1 Structural idealization

The member shall be idealized as a series of tension ties and concrete struts interconnected at nodes to form a truss, to carry the loads to the supports.

In the idealization, the size of the struts and ties shall be no larger than the capacity of the nodes to transfer forces between the elements of the idealization.

12.1.2.2 Concrete strut

The ultimate strength of the concrete strut shall be taken as not greater than $b_c d_c f_{c,cal}$,

where

b_c = the width of the compression strut

d_c = the depth of the compression strut

$f_{c,cal} = (0.8 - f'_c / 200) f'_c$

12.1.2.3 Nodes

Where the design compressive stress incident on the nodes exceeds $\phi f_{c,cal}$, confinement reinforcement shall be provided.

12.1.2.4 *Tension tie*

The tension tie shall be effectively anchored, in accordance with Section 13, to transfer the force to the node of the truss.

12.1.2.5 *Additional reinforcement*

Additional reinforcement shall be provided to ensure adequate serviceability and to protect against the splitting of compression zones at stress concentrations or regions of high load intensity.

12.1.2.6 *Additional requirements for corbels*

Corbels designed as cantilevered deep beams, on the basis of concrete strut and tension tie action, shall take into account horizontal forces and movements from the supported members and shall comply with the following:

- (a) The depth of the outside face shall be not less than half the depth at the face of the support.
- (b) The line of action of the load may be taken at the outside edge of the bearing pad if any, or at the commencement of any edge chamfer, or at the outside face of the corbel as appropriate. Where a flexural member is being supported, the outside face of the corbel shall be protected against spalling.
- (c) The tensile reinforcement shall be anchored at the free end of the corbel either by a welded or mechanical anchorage or by forming a loop in either a vertical or horizontal plane. Where the main reinforcement is looped, the loaded area shall not project beyond the straight portion of this reinforcement.
- (d) Additional horizontal tensile reinforcement, having a total area equal to half of the main tensile reinforcement area, shall be distributed over the upper two-thirds of the corbel.

12.1.2.7 *Additional requirements for continuous concrete nibs*

Continuous nibs designed as short cantilever slabs, on the basis of concrete strut and tension tie action, shall take into account horizontal forces and movements from the supported members and shall comply with the following:

- (a) The projection of the nib shall provide adequate bearing for the type of member supported, but shall be not less than 100 mm.
- (b) The line of action of the load may be taken at the outside edge of the bearing pad if any, or at the commencement of any edge chamfer, or at the outside face of the nib as appropriate. Where a flexural member is being supported, the outside face of the nib shall be protected against spalling.
- (c) The tensile reinforcement shall be anchored at the free end of the nib either by a welded or mechanical anchorage, or by forming a loop in either the vertical or horizontal plane. Vertical loops shall be fabricated from bars of size not greater than 12 mm. Where the main reinforcement is looped, the loaded area shall not project beyond the straight portion of this reinforcement.

12.1.2.8 *Additional requirements for stepped joints*

Stepped joints designed as short cantilevers, on the basis of concrete strut and tension tie action, shall take into account the horizontal forces and movements from the supported members and shall comply with the following:

- (a) The horizontal reinforcement shall extend at least a distance equal to the beam depth (D) beyond the step and shall be provided with anchorage beyond the plane of any potential shear crack.

- (b) In pretensioned members, the vertical component of the force in the prestressing steel shall be ignored.

12.1.3 Design based on stress analysis

12.1.3.1 Analysis

The ultimate strength of a deep beam, pile cap or footing, based on stress analysis, shall use a linear or non-linear analysis for the design loads, in accordance with accepted principles of mechanics.

12.1.3.2 Compressive strength

The ultimate compressive strength of the section shall be taken as the compressive stress ($f_{c.ca}$) calculated in accordance with Clause 12.1.2.2. It shall be permissible to average the calculated compressive stress over 100 mm, to reduce peak values.

Reinforcement, normal to the direction of the compressive stress, shall be provided to inhibit splitting in areas of high compressive stress.

12.1.3.3 Tensile forces

All tensile forces shall be taken by reinforcement fully anchored in accordance with Clause 13.1.

12.1.4 Empirical design methods

The ultimate strength of a non-flexural member may be based on design methods derived from test results, provided that the proportions of the member and the configurations of the reinforcement are within the range tested.

12.2 ANCHORAGE ZONES FOR PRESTRESSING ANCHORAGES

12.2.1 Application

This Clause applies to the design of rectangular anchorage zones in post-tensioned concrete members but is limited to cases having no more than two anchorages in any elevation or plan.

An anchorage zone is the zone between the loaded face and the cross-section at which a linear distribution of stress due to prestress is achieved.

12.2.2 General

Reinforcement shall be provided to carry tensile forces that arise from the action and dispersal of the prestressing forces in anchorage zones.

In general, the dispersal occurs through both the depth and the width of the anchorage zone, and reinforcement shall, therefore, be provided in planes parallel to the end faces in two orthogonal directions. A two-dimensional analysis for each loading case shall be carried out in each direction in turn. The tensile forces shall be calculated on longitudinal sections through anchorages and on longitudinal sections where peak values of transverse moments occur.

The transverse moment on a longitudinal section is the equilibrating moment acting on the free body bounded by the longitudinal section, a free surface parallel to it, the loaded face, and a plane parallel to the loaded face at the inner end of the anchorage zone.

12.2.3 Loading cases to be considered

Loading cases to be considered shall include—

- (a) all anchorages loaded; and
- (b) critical loadings during the stressing operation.

Where the distance between two anchorages is less than 0.3 times the total depth, or breadth, of the member, consideration shall be given to the effects of the pair acting in a manner similar to a single anchorage subject to the combined forces.

12.2.4 Calculation of tensile forces along line of an anchorage force

The force resultant of transverse tensile stresses induced along the line of action of an anchorage force shall be taken as:

$$T = 0.25P(1 - k_r)$$

where

P = the maximum force occurring at the anchorage during jacking

k_r = the ratio of the depth, or breadth, of an anchorage bearing plate to the corresponding depth, or breadth, of the symmetrical prism

The symmetrical prism is defined as a notional prism with an anchorage at the centre of its end face and a depth, or breadth, taken as twice the distance from the centre of an anchorage to the nearer concrete face.

12.2.5 Calculation of tensile forces induced near the loaded face

At longitudinal sections remote from a single eccentric anchorage, or between widely spaced anchorages, where the sense of the transverse moment indicates that the tensile stress resultant acts near the loaded face, the tensile force shall be calculated as follows:

- (a) For a single eccentric anchorage, by dividing the peak transverse moment by a lever arm assumed to be one half the overall depth of the member.
- (b) Between pairs of anchorages, by dividing the peak transverse moment by a lever arm assumed to be 0.6 times the spacing of the anchorages.

12.2.6 Quantity and distribution of reinforcement

The cross-sectional area of reinforcement for each situation shall be calculated by dividing the tensile forces derived in accordance with Clauses 12.2.4 and 12.2.5 by 150 MPa. This reinforcement shall be distributed as follows:

- (a) Reinforcement to resist the forces calculated under Clause 12.2.4 distributed uniformly from $0.2D$ to $1.0D$ from the loaded face. Similar reinforcement shall be placed from the plane at $0.2D$ as near as practicable to the loaded face. D shall be equal to the depth or breadth of the symmetrical prism as appropriate.
- (b) Reinforcement to resist the forces calculated under Clause 12.2.5 placed as close to the loaded face as is consistent with cover and compaction requirements.

At any plane parallel to the loaded face, the reinforcement shall be determined from the longitudinal section with the greatest reinforcement requirements at that plane, and shall extend over the full depth or breadth of the end zone.

12.3 BEARING SURFACES

Unless special confinement reinforcement is provided, the design bearing stress at a concrete surface shall not exceed $\phi 0.85 f'_c \sqrt{(A_2 / A_1)}$, or $\phi 2 f'_c$, whichever is less,

where

A_2 = the largest area of the supporting surface that is geometrically similar to and concentric with A_1

A_1 = the bearing area

In the case of a bearing surface where the supporting structure is sloped or stepped, it shall be permissible to take A_2 as the area of the base of the largest frustum of a right pyramid or cone—

- (a) having for its opposite end the bearing area A_1 ;
- (b) having side slopes of 1 longitudinally to 2 transversely, with respect to the direction of the load; and
- (c) contained wholly within the supporting structure.

SECTION 13 STRESS DEVELOPMENT AND SPLICING OF REINFORCEMENT AND TENDONS

13.1 STRESS DEVELOPMENT IN REINFORCEMENT

13.1.1 General

The calculated force in reinforcing steel at any cross-section shall be developed on each side of that cross-section in accordance with Clauses 13.1.2 to 13.1.7.

13.1.2 Development length for bar in tension

13.1.2.1 *Development length to develop yield strength*

The development length ($L_{sy,t}$) to develop the yield strength (f_{sy}) of a bar in tension shall be calculated as follows:

(a) For all deformed bars:

$$L_{sy,t} = \frac{k_1 k_2 f_{sy} A_b}{(2a + d_b) \sqrt{f'_c}} \geq 25k_1 d_b$$

where

k_1 = 1.25 for a horizontal bar with more than 300 mm of concrete cast below the bar; or

= 1.0 for all other bars

k_2 = 1.7 for bars in slabs and walls if the clear distance between adjacent parallel bars developing stress is not less than 150 mm

= 2.2 for longitudinal bars in beams and columns with fitments

= 2.4 for any other longitudinal bar

A_b = the cross-sectional area of the reinforcing bar

$2a$ = twice the cover to the deformed bar or the clear distance between adjacent parallel bars developing stress, whichever is less

(b) For plain bars used as fitments, where $d_b < 13$ mm,

$$L_{sy,t} = 40d_b \text{ but not less than 300 mm:}$$

(c) For hard-drawn wire:

$$L_{sy,t} = 50d_b$$

13.1.2.2 *Development length to develop less than yield strength*

The development length (L_{st}) to develop a tensile stress (σ_{st}) less than the yield strength (f_{sy}) shall be calculated from—

$$L_{st} = L_{sy,t} \sigma_{st} / f_{sy}$$

but shall be not less than—

(a) $12 d_b$; or

(b) for slabs, as permitted by Clause 9.1.3.1(a)(ii).

13.1.2.3 *Development length around a curve*

Tensile stress may be considered to be developed around a curve if the internal diameter of the curve is $10d_b$ or greater.

13.1.2.4 *Development length of a bar with a standard hook*

Where a bar ends in a standard hook complying with Clause 13.1.2.5, the tensile development length of that end of the bar, measured from the outside of the hook, shall be taken as $0.5L_{sy,t}$ or $0.5L_{st}$ as applicable.

13.1.2.5 *Standard hooks*

The standard hook referred to in Clause 13.1.2.4, shall be one of the following —

- (a) a hook consisting of a 135° or 180° bend with a nominal internal diameter complying with Clause 19.2.3.2 plus a straight extension of $4d_b$ or 70 mm whichever is greater; or
- (b) a cog, consisting of a 90° bend with a nominal internal diameter complying with Clause 19.2.3.2 but not greater than $8d_b$ and having the same total length as required for a 180° hook of the same diameter bar.

13.1.2.6 *Development of headed reinforcement*

If the cross-sectional area of the head of the headed reinforcement or the area of the end plate for bars mechanically anchored with an end plate (see Clause 13.1.6), in the plane perpendicular to the axis of the bar, is at least 10 times the cross-sectional area of the bar, the bar shall be considered as fully anchored.

13.1.2.7 *Development length of plain bars*

The development length of plain bars shall rely on standard hooks as defined in Clause 13.1.2.5 except that the straight extension shall be the greater of $8d_b$ or 140 mm.

13.1.3 Development length for a bar in compression

The development length ($L_{sy,c}$) to develop the yield strength (f_{sy}) in compression in a deformed bar shall be taken as $20d_b$.

A bend or a standard hook shall not be considered effective in developing stress in reinforcement in compression.

13.1.4 Development length of bundled bars

The development length of a unit of bundled bars shall be based on the development length required for the largest bar within the bundle increased by—

- (a) for a 3-bar bundle 20%; and
- (b) for a 4-bar bundle 33%.

13.1.5 Development length of mesh in tension

The development length in tension for longitudinal wires of welded wire mesh shall be deemed to be provided by an embedment of at least two transverse wires so that the closer one is not less than 25 mm from the critical section concerned.

13.2 SPLICING OF REINFORCEMENT

13.2.1 General

The following general requirements shall apply to the splicing of reinforcement:

- (a) Splices of reinforcement shall be made only as required or permitted on the design drawings or in specifications.

- (b) The splice shall be made by welding, by mechanical means, by end-bearing, or by lapping.
- (c) Splicing of reinforcement shall take into account the requirements of Clause 19.1.3 regarding the placement of concrete.
- (d) Splices required in bars in tension tie members shall be made only by welding or mechanical means.
- (e) Lapped splices shall not be used for bars in compression with diameter larger than 40 mm and for bars in tension with diameter larger than 32 mm.
- (f) Welding of reinforcing bars shall not be made less than $3d_b$ from that part of a bar that has been bent and re-straightened.

13.2.2 Lapped splices for bars in tension

The lap length for splices for bars in tension shall be not less than the development length, ($L_{sy,t}$) given in Clause 13.1.2.1.

13.2.3 Lapped splices for mesh in tension

A lapped splice for welded wire mesh in tension shall be made so that the two outermost transverse wires of one sheet of mesh overlap the two outermost transverse wires of the sheet being lapped as shown in Figure 13.2.3.



FIGURE 13.2.3 LAPPED SPLICES FOR MESH

13.2.4 Lapped splices for bars in compression

The minimum length of a lapped splice for deformed bars in compression shall be the development length in compression ($L_{sy,c}$) given in Items (a), (b) or (c), as appropriate, but shall be not less than 300 mm, as follows:

- (a) The development length in compression shall be in accordance with Clause 13.1.3 but not less than $0.07f_{sy}d_b$ for f_{sy} of 400 MPa or less, or $(0.125f_{sy} - 22)d_b$ for f_{sy} greater than 400 MPa.
- (b) In compression members with stirrups or ties where at least 3 sets of ties are present over the length of the lap and $A_{tr}/s \geq A_b/1000$, a lap length of 0.8 times the value given in Item (a).
- (c) In helically tied compression members, if at least 3 turns of helix are present over the length of the lap and $A_{tr}/s \geq nA_b/6000$, a lap length of 0.8 times the value given in Item (a).

In this Clause, A_b is defined as the area of the bar being spliced.

13.2.5 Lapped splices for bundled bars

Lapped splices for a unit of bundled bars shall be based on the lap splice length required for the largest bar within the bundle increased by —

- (a) for a 3-bar bundle 20%; and
- (b) for a 4-bar bundle 33%.

Individual bar splices within a bundle shall not overlap.

13.3 STRESS DEVELOPMENT IN TENDONS

13.3.1 General

The calculated force in tendons at any cross-section shall be developed on each side of that cross-section in accordance with Clause 13.3.2 or Clause 13.3.3.

13.3.2 Development length of pretensioned tendons

In the absence of substantiated test data, the development length (L_p) of pretensioned tendons for gradual release shall be taken as the transmission length given in Table 13.3.2, as appropriate to type of tendon and the strength of the concrete at transfer (f_{cp}).

Where strand or wire is untensioned, the development length shall be taken as not less than 1.5 times the value given in Table 13.3.2, as appropriate.

It shall be assumed that no change in the position of the inner end of the transmission length occurs with time but that a completely unstressed zone of length $0.1L_p$ develops at the end of the tendon.

TABLE 13.3.2

MINIMUM TRANSMISSION LENGTH FOR PRETENSIONED TENDONS

Type of tendon	L_p for gradual release	
	$f_{cp} \geq 32$ MPa	$f_{cp} < 32$ MPa
Indented wire	100 d_b	175 d_b
Crimped wire	70 d_b	100 d_b
Regular, super and compact strand	60 d_b	60 d_b

NOTES:

- 1 Sudden release of a tendon at transfer may cause large increases above the values tabulated.
- 2 The transmission lengths towards the top of a member may be as much as twice the values tabulated.

13.3.3 Stress development in post-tensioned tendons by anchorages

Anchorages for tendons shall be capable of developing in the tendon the minimum tensile strength (f_p).

In addition, anchorages for unbonded tendons shall be capable of sustaining cyclic loading conditions.

13.4 COUPLING OF TENDONS

Coupling of tendons shall comply with the following:

- (a) Couplers shall be capable of developing the minimum tensile strength (f_p).
- (b) Couplers shall be enclosed in housings of sufficient length to permit the necessary movements and to facilitate grouting of the duct.

SECTION 14 JOINTS, EMBEDDED ITEMS, FIXINGS AND CONNECTIONS

14.1 DESIGN OF JOINTS

14.1.1 Construction joints

A construction joint, including a joint between precast segments, in a part of a structure or member shall be designed and constructed so that the load-carrying capacity and serviceability of the structure or member will be unimpaired by the inclusion of the joint.

14.1.2 Movement joints

A movement joint in a part of a structure or member shall be designed and constructed so that the assessed relative movement or rotation, between the parts of the structure or member on either side of the joint, can occur without impairing the load-carrying capacity and serviceability of the structure or member.

14.2 EMBEDDED ITEMS AND HOLES IN CONCRETE

14.2.1 General

Embedded items and holes shall be permitted in concrete members provided that the required strength and serviceability of the member is satisfied.

For the purpose of this Clause embedded items include pipes and conduits with their associated fittings, sleeves, permanent inserts for fixings and other purposes, holding-down bolts, bar chairs and other supports.

For the purpose of this Clause, holes include holes through a member, holes along the length of a member, rebates, and penetrations.

14.2.2 Limitation on materials

The materials to be embedded shall comply with the following requirements, as appropriate:

- (a) Conduits and pipes used for electrical purposes shall comply with the relevant requirements of AS/NZS 3000.
- (b) Other embedded items shall be protected from corrosion or deterioration.
- (c) Metals such as aluminium shall not be embedded in structural concrete unless effectively coated, covered, or treated to prevent chemical action between the metal and the concrete and electrolytic action between the metal and steel.

14.2.3 Pipes containing liquid, gas or vapour

Pipes that are intended to contain liquid, gas or vapour under pressure or extremes of temperature may be embedded in structural concrete, provided that—

- (a) the maximum pressure to which any piping or fitting is intended to be subjected shall not exceed 2000 kPa; and
- (b) the effect that inclusion of the pipe has on the strength and serviceability behaviour of the member, is taken into account.

14.2.4 Spacing and cover

The minimum clear distance between embedded items and between embedded items and bars (including bundled bars), tendons, or ducts, shall be sufficient to ensure that the concrete can be placed and compacted to comply with Clause 19.1.3.

The cover to embedded items that are not corrosion resistant shall comply with Section 4.

14.3 REQUIREMENTS FOR FIXINGS

Fixings, including holding-down bolts, inserts and ferrules, shall comply with the following:

- (a) A fixing shall be designed to transmit all forces, acting or likely to act on it.
- (b) Forces on fixings used for lifting purposes shall include an impact factor in assessing the load.
- (c) Fixings shall be designed to yield before ultimate failure in the event of overload.
- (d) The anchorage of any fixings shall be designed in accordance with Section 13, as appropriate. The design strength of this anchorage shall be taken as ϕ times the ultimate strength where $\phi = 0.5$. In the case of shallow anchorages, cone-type failure in the concrete surrounding the fixing shall be investigated taking into account edge distance, spacing, the effect of reinforcement, if any, and concrete strength at time of loading.
- (e) In the absence of calculations, the strength of a fixing shall be determined by load testing of a prototype to failure in accordance with Appendix B, Paragraph B4. The design strength of the fixing shall be taken as ϕ times the ultimate strength where the ultimate strength is taken as the average failure load divided by the appropriate factor given in Table B4.3 and $\phi = 0.6$.
- (f) The spacing between, and cover to fixings shall be in accordance with Clause 14.2.4. The cover for fire resistance shall be in accordance with Section 5.

Fixings that are intended for lifting purposes shall have a ratio of ultimate strain to either yield strain or proportional limit strain of not less than 3.

14.4 CONNECTIONS

Monolithic connections between structural members shall be detailed to transmit the design action effects including allowance for any possible reversals of actions or action effects.

SECTION 15 PLAIN CONCRETE MEMBERS

15.1 APPLICATION

Plain concrete shall be used only for members in which a crack will not induce collapse. The requirements of this Section may be applied to plain concrete floors and pavements resting on the ground, footings and bored piers.

15.2 DESIGN

15.2.1 Basic principles of strength design

Members shall be designed in accordance with the following basic principles:

- (a) Design of members for flexure shall be based on a linear stress-strain relationship in both tension and compression.
- (b) The tensile strength of concrete may be considered in the design.
- (c) No strength shall be assigned to reinforcement that may be present.

15.2.2 Section properties

In the calculation of strength, the entire cross-section of a member shall be considered except that for a member cast against soil, the overall relevant dimension shall be taken as 50 mm less than the actual dimension.

15.3 STRENGTH IN BENDING

The design strength of a member in bending shall be taken as ϕM_{uo} , where M_{uo} is calculated using the characteristic flexural tensile strength (f'_{ct}).

15.4 STRENGTH IN SHEAR

15.4.1 One-way action

Where the member acts essentially as a one-way member, and a shear failure can occur across the width, b , of the member, the design strength in shear shall be taken as ϕV_u where:

$$V_u = 0.15bD(f'_c)^{1/3}$$

The maximum shear shall be taken to occur at a distance $0.5D$ from the face of a support.

15.4.2 Two-way action

Where a shear failure can occur locally around a support or loaded area, the design strength in shear shall be taken as—

$$\phi V_u / [1 + (uM^* / 8V^* aD)]$$

where

$$V_u = 0.1uD(1 + 2/\beta_h)\sqrt{f'_c} \leq 0.2uD\sqrt{f'_c}$$

and

- u = the effective length of the critical shear perimeter (see Figure 9.2.1(A))
- a = the dimension of the critical shear perimeter, which is parallel to the direction of bending being considered (see Figure 9.2.1(B)).
- β_h = the ratio given in Clause 9.2.1

15.5 STRENGTH IN AXIAL COMPRESSION

The design strength under axial compression of a member, other than a wall, shall be taken as ϕN_{uo} ,

where—

$$N_{uo} = 0.45 f'_c A_g$$

provided that the unsupported length of the member is not greater than three times the least lateral dimension, except that this restriction does not apply to bored piers cast in-situ.

15.6 STRENGTH IN COMBINED BENDING AND COMPRESSION

In the absence of more exact calculations, members subject to combined bending and axial load shall be designed so that—

$$\frac{M_x^*}{\phi M_{ux}} + \frac{M_y^*}{\phi M_{uy}} + \frac{N^*}{\phi N_u} \leq 1$$

SECTION 16 CONCRETE PAVEMENTS, FLOORS AND RESIDENTIAL FOOTINGS

16.1 APPLICATION

This Section gives additional design considerations for in situ concrete slabs cast on the ground for industrial, commercial and residential uses; concrete pavement slabs for parking areas and private roads and residential footings.

16.2 ADDITIONAL DESIGN CONSIDERATIONS FOR PAVEMENTS AND INDUSTRIAL AND COMMERCIAL FLOORS

16.2.1 Foundation

The foundation shall be investigated and suitably modified, where necessary, to ensure that the sustained and any intermittent service loads, can be resisted by the slab without undue differential or uniform settlement.

16.2.2 Thickness of the slab

The thickness of the slab shall be proportioned to adequately distribute concentrated loads to the foundation.

16.2.3 Reinforcement and joints

The reinforcement and the spacing, pattern and type of joints, shall be designed to minimize cracking due to shrinkage and warping.

16.3 RESIDENTIAL FLOORS AND FOOTINGS

Where appropriate, residential slabs and footings shall be designed and constructed in accordance with AS 2870.

SECTION 17 LIQUID RETAINING STRUCTURES — DESIGN REQUIREMENTS

Reinforced or prestressed concrete structures, which are intended for the retention of aqueous liquids at ambient temperatures, shall be designed and detailed in accordance with AS 3735 or AS 2783 as appropriate.

SECTION 18 MARINE STRUCTURES

18.1 APPLICATION

This Section gives additional requirements for fixed structures in shallow waters.

18.2 ADDITIONAL LOADS AND ACTIONS

18.2.1 Environmental loads

Loads due to environmental effects shall be taken into account in the design. Consideration shall be given to the likely effects of loads due to waves, tides, currents and storm surges and to the possible superposition of these loads and those due to other environmental effects such as wind or earthquake.

18.2.2 Live loads

Live loads shall be specifically considered for the structure in accordance with its anticipated use, taking account of any materials handling requirements and the enhancement of forces due to impact.

18.2.3 Berthing and mooring loads

Loads due to the berthing and mooring of ships shall be taken into account in the design. Berthing loads shall be factored as for live loads and mooring loads shall be factored as for wind loads.

18.2.4 Vibration and movement

The deformation of individual members and the structure as a whole under service loads shall be checked to ensure that vibrations or movements induced by wind, waves, currents, berthing or machinery will not adversely affect the serviceability of the structure.

18.3 ADDITIONAL DURABILITY AND DESIGN REQUIREMENTS

18.3.1 Abrasive tidal or wave action

Structures exposed to abrasive tidal or wave action shall be specifically designed for such cases and suitable provisions to ensure durability shall be specified.

18.3.2 Cathodic protection

If cathodic protection, either sacrificial anode or impressed current, is applied to part of the structure, including adjacent steelwork, then the design of the system shall take into account the dangers of corrosion of reinforcing steel in the total structure.

18.3.3 Marine growth

Allowance shall be made for the increase in sectional area and alteration of surface characteristics due to extensive marine growth, on fully or partially submerged members that are sensitive to such changes.

SECTION 19 MATERIAL AND CONSTRUCTION REQUIREMENTS

19.1 MATERIAL AND CONSTRUCTION REQUIREMENTS FOR CONCRETE AND GROUT

19.1.1 Materials and limitations on constituents

Materials for concrete and grout, and limitations on their chemical content, shall comply with the relevant requirements of AS 1379 and this Clause.

Where control of shrinkage or creep, or both, is a design requirement for concretes manufactured with type GP or HE cements, the acid-soluble sulphate content of the concrete from all mix sources, expressed as the proportion of SO₃ by mass, shall be not less than 20 g/kg of cement.

19.1.2 Specification and manufacture of concrete

Concrete to which this Standard applies shall be—

- (a) specified as either normal-class or special-class and manufactured and supplied in accordance with AS 1379; and
- (b) handled, placed, compacted, finished and cured in accordance with this Standard, so that the hardened concrete will satisfy the design requirements for strength, serviceability and durability.

Project assessment shall be specified for special-class concrete specified by strength grade and may be specified for normal-class concrete and other special-class concrete, all as defined in AS 1379.

19.1.3 Handling, placing and compacting of concrete

Concrete shall be handled, placed and compacted so as to—

- (a) limit segregation or loss of materials;
- (b) limit premature stiffening;
- (c) produce a monolithic mass between planned joints or the extremities of members, or both;
- (d) completely fill the formwork to the intended level, expel entrapped air, and closely surround all reinforcement, tendons, ducts, anchorages and embedments; and
- (e) provide the specified finish to the formed surfaces of the member.

19.1.4 Finishing of unformed concrete surfaces

Unformed concrete surfaces shall be finished by appropriate methods, to achieve the specified—

- (a) dimensions, falls, tolerances, or similar details relating to the shape and uniformity of the surfaces;
- (b) cover from the surfaces to reinforcement, tendons, ducts and embedments; and
- (c) texture of the surface.

19.1.5 Curing and protection of concrete

19.1.5.1 *Curing*

Concrete shall be cured continuously for a period of time that ensures that the design requirements for strength, serviceability and stripping are satisfied. To satisfy durability requirements, the initial curing periods shall be not less than those given in Clauses 4.4 to 4.6.

Curing shall be achieved by the application of water or steam to, or the retention of water in, the freshly cast concrete and shall commence as soon as practicable after finishing of any unformed surfaces has been completed. Where retention of water in the fresh concrete relies on the application to exposed surfaces of sprayed membrane-forming curing compounds, the compounds used shall comply with AS 3799.

Curing requirements for the various elements of the structure shall be detailed in the project specification.

19.1.5.2 *Protection*

Freshly cast concrete shall be protected from the effects of rain, running water and freezing or drying prior to hardening. During the initial curing period the concrete shall be protected from freezing or drying.

19.1.6 Sampling and testing for compliance

19.1.6.1 *General*

Concrete, which is intended for use in structures designed in accordance with this Standard, shall be assessed in accordance with AS 1379 for compliance with the specified parameters.

NOTE: When project assessment is required, the project specification should nominate responsibility for carrying out the relevant sampling, testing and assessment and, if these differ from or are not covered by AS 1379, should give details of how the assessment is to be made.

19.1.6.2 *Concrete specified by strength grade*

Concrete specified by strength grade shall satisfy the following criteria:

- (a) For each strength grade of concrete supplied to a project, the mean grade strength, as defined in AS 1379, shall be maintained within the limits specified in that Standard.
- (b) For concrete subject to project assessment—
 - (i) the slump of the supplied concrete shall be within the tolerance specified in AS 1379 for the relevant specified slump; and
 - (ii) in addition to Item (a), the mean compressive strength of the representative samples taken from the project shall be statistically consistent with the relevant specified characteristic strength.

NOTES:

- 1 'Strength grade' is defined in AS 1379 as 'the specified value of the characteristic compressive strength of the concrete at 28 days f'_c '
- 2 The compressive strength of the concrete sampled, tested and assessed in accordance with AS 1379 indicates the potential strength of the supplied concrete, when placed, compacted and cured under optimum conditions; the responsibility of demonstrating which rests on the supplier. The achievement of that potential on site is dependent upon the handling, placing, compacting and curing techniques actually used; the responsibility for which rests with the construction contractor (see Clauses 19.1.3 and 19.1.5). Information on appropriate site techniques may be found in HB64 and HB67.

19.1.6.3 *Concrete specified by parameters other than strength grade*

When concrete is specified by parameters other than strength grade, the method of production control and, if required, project control shall be specified together with the relevant compliance criteria.

The specified methods of control and assessment shall provide a reliable operating characteristic curve so that—

- (a) concrete with a proportion defective of 0.05 has a probability of acceptance of not less than 50%; and
- (b) concrete with a proportion defective of 0.30 has a probability of rejection of not less than 98%.

19.1.7 **Rejection of concrete**

19.1.7.1 *Plastic concrete*

Plastic concrete may be rejected if, after completion of mixing but prior to site handling—

- (a) the slump, determined in accordance with AS 1012.3, differs from the specified slump by more than the tolerances permitted in AS 1379;
- (b) the elapsed time from first introduction of the mixing water is outside the time interval allowed in AS 1379; or
- (c) the appearance and cohesiveness of a particular quantity is significantly different from previously supplied quantities of the same specification.

19.1.7.2 *Hardened concrete*

Hardened concrete shall be liable to rejection if—

- (a) it does not satisfy the requirements of Clause 19.1.6;
- (b) it is porous, segregated, or honeycombed, or contains surface defects; or
- (c) it fails to comply with the other requirements of this Standard.

19.1.7.3 *Action on hardened concrete liable to rejection*

Where hardened concrete is liable to rejection in terms of Clause 19.1.7.2, the concrete may be accepted if it can be demonstrated, either by calculation or by testing in accordance with the appropriate clauses of Appendix B, that the structural adequacy and intended use of the affected members are not significantly impaired. Otherwise, the concrete shall be rejected.

19.1.8 **Requirements for grout and grouting**

19.1.8.1 *Grout properties*

Grout shall be proportioned to give the desired properties for its intended use. Grout to be used in grouting prestressing ducts shall have sufficient fluidity to enable it to be pumped through the duct, have low sedimentation and shrinkage, and contain no more than 750 mg of chloride ions per litre of grout.

19.1.8.2 *Mixing and agitation*

Grout shall be mixed in a mixer capable of producing a uniform grout of the specified fluidity and free from lumps of undispersed cement.

After mixing, grout shall be held in an agitation tank and kept in motion, to prevent settlement or segregation occurring, before it is pumped into its final position.

19.2 MATERIAL AND CONSTRUCTION REQUIREMENTS FOR REINFORCING STEEL

19.2.1 Materials

19.2.1.1 Reinforcement

Reinforcement shall be deformed Class N bars, or Class L or Class N welded wire mesh (plain or deformed), with a yield strength of up to 500 MPa, except that fitments may be manufactured from Class L wire or bar, or plain Class N bar.

All reinforcement shall comply with AS 1302, AS 1303, AS 1304 or AS/NZS 4671 as appropriate.

19.2.1.2 Protective coatings

A protective coating may be applied to reinforcement provided that such coating does not reduce the properties of the reinforcement below those assumed in the design.

19.2.2 Fabrication

- (a) Reinforcement shall be fabricated to the shape and dimensions shown in the drawings and within the following tolerances—
 - (i) On any overall dimension for bars and mesh except where used as a fitment:
 - (A) For lengths up to 600 mm -25, +0 mm.
 - (B) For lengths over 600 mm -40, +0 mm.
 - (ii) On any overall dimension of bars or mesh used as a fitment:
 - (A) For deformed bars and mesh -15, +0 mm.
 - (B) For plain round bars and wire -10, +0 mm.
 - (iii) On the overall offset dimension of a cranked column bar -0, +10 mm.
 - (iv) For the sawn or machined end of a straight bar intended for use as an end-bearing splice, the angular deviation from square, measured in relation to the end 300 mm, shall be within 2°.
- (b) Bending of reinforcement shall comply with Clause 19.2.3.
- (c) Welding if required shall comply with AS 1554.3. Tack welding not complying with that Standard shall not be used.

19.2.3 Bending

19.2.3.1 General

Reinforcement may be bent either—

- (a) cold, by the application of a force, around a pin of diameter complying with Clause 19.2.3.2, so as to avoid impact loading of the bar and mechanical damage to the bar surface; or
- (b) hot, provided that—
 - (i) the steel is heated uniformly through and beyond the portion to be bent;
 - (ii) the temperature of the steel does not exceed 600°C;
 - (iii) the bar is not cooled by quenching; and
 - (iv) if during heating the temperature of the bar exceeds 450°C, the design yield strength of the steel after bending shall be taken as 250 MPa.

Reinforcement that has been bent and subsequently straightened or bent in the reverse direction shall not be bent again within 20 bar diameters of the previous bend.

Reinforcement partially embedded in concrete may be field bent provided that the bending complies with Items (a) or (b) above and the bond of the embedded portion is not impaired thereby.

19.2.3.2 Internal diameter of bends or hooks

The nominal internal diameter of a reinforcement bend or hook shall be taken as the external diameter of the pin around which the reinforcement is bent. The diameter of the pin shall be not less than the value determined from the following as appropriate:

- (a) For fitments of—
 - (i) wire $3d_b$
 - (ii) grade 250 bars $3d_b$; and
 - (iii) grade 400 and 500 bars $4d_b$.
- (b) For reinforcement, other than that specified in Items (c) and (d) below, of any grade $5d_b$.
- (c) For reinforcement, in which the bend is intended to be subsequently straightened or rebent, of—
 - (i) 16 mm diameter or less $4d_b$;
 - (ii) 20 mm diameter or 24 mm $5d_b$; and
 - (iii) 28 mm diameter or greater $6d_b$.

Any such straightening or rebending shall be clearly specified or shown in the drawings.
- (d) For reinforcement that is epoxy-coated or galvanized, either before or after bending, of—
 - (i) 16 mm diameter or less $5d_b$;
 - (ii) 20 mm diameter or greater $8d_b$.

19.2.4 Surface condition

At the time concrete is placed, the surface condition of reinforcement shall be such as not to impair its bond to the concrete or its performance in the member. The presence of millscale or surface rust shall not be cause for rejection of reinforcement under this Clause.

19.2.5 Fixing

All reinforcement, including secondary reinforcement provided for the purpose of maintaining main reinforcement and tendons in position, shall be supported and maintained in position within the tolerances given in Clause 19.5.3 until the concrete has hardened. Bar chairs, spacers and ties used for this purpose shall be made of concrete, steel or plastics, as appropriate.

19.2.6 Lightning protection by reinforcement

Where lightning protection is to be provided by the reinforcement, the reinforcement shall comply with the relevant requirements of AS 1768.

19.3 MATERIAL AND CONSTRUCTION REQUIREMENTS FOR PRESTRESSING DUCTS, ANCHORAGES AND TENDONS

19.3.1 Materials for ducts, anchorages and tendons

19.3.1.1 Ducts

Sheaths and removable formers used to form ducts shall be capable of maintaining their required cross-section and profile during construction.

19.3.1.2 Anchorages

The quality and properties of anchorages shall be established by testing.

19.3.1.3 Tendons

Prestressing tendons shall comply with AS 1310, AS 1311, and AS 1313, as applicable.

Tendons shall not be galvanized.

In the absence of assurance, such as a manufacturer's certificate, the quality of tendons shall be established by testing in accordance with the applicable Standards.

Hard-drawn, high tensile steel wire, which has not been stress-relieved, shall not be used for wire winding unless its elongation, tested in accordance with AS 1310, is 2% or greater.

Plain wire shall not be used for pretensioning.

19.3.2 Construction requirements for ducts

19.3.2.1 Surface condition

When concrete is placed, the outside surface of sheaths and formers for ducts shall be such as not to impair bond of the concrete to the duct. Immediately before grouting, the inside surfaces of sheaths shall be such as not to impair bond of the grout to the duct.

Where an extractable core is used, a suitable technique shall be chosen to ensure its withdrawal, without damage to the formed duct.

19.3.2.2 Sealing

Prior to the placing of concrete, ducts shall be sealed at the ends and at all joints, to exclude concrete, or other matter.

19.3.2.3 Fixing

Ducts shall be supported and fixed at regular intervals so that the required tendon profile will be maintained in accordance with Clause 19.5.3.

19.3.3 Construction requirements for anchorages

19.3.3.1 Fixing

Anchorage shall be fixed strictly in accordance with the supplier's recommendations and the following:

- (a) The anchorage shall be square to the line of the tendon.
- (b) The duct shall be securely attached to the anchorage so that it provides a grout-tight joint between the duct and the anchorage.
- (c) Where the anchorage is fixed to the formwork, the joint between the two parts shall be grout-tight.

19.3.3.2 Surface condition

At the time concrete is placed, the surface condition of the anchorage shall be such as not to impair its bond to the concrete.

19.3.4 Construction requirements for tendons

19.3.4.1 Fabrication

Tendons shall be fabricated in accordance with the following:

- (a) Cutting of tendons shall be carried out so that damage to tendons, ducts and anchorages is avoided.
- (b) Tendons shall not be welded.
- (c) Prestressing bars shall be within manufacturing tolerances and not bent in the threaded portion.

Small adjustments on site shall be carried out cold provided that when the bar temperature is lower than 10°C, the bar temperature shall be raised above this value by means of steam or hot water.

19.3.4.2 Protection

Before stressing, tendons shall be protected from stray current arcing and splashes from the cutting operation of an oxy-acetylene torch or an arc-welding process.

The threaded ends of prestressing bars shall be provided with suitable protection, at all times.

If tendons are to have a coating or wrapping, such coating or wrapping shall be inert with respect to both the steel and the concrete.

After stressing and anchoring, all tendons and anchorages shall be protected from physical damage and corrosion.

19.3.4.3 Surface condition

The surface condition of tendons shall be such as not to impair bond to the concrete or grout, or performance in the member.

The presence of a slight film of rust shall not be cause for rejection of ducts under this Clause unless the steel is visibly pitted.

19.3.4.4 Fixing

All tendons shall be supported and maintained in position within the permissible tolerances given in Clause 19.5.3 until the concrete has hardened.

19.3.4.5 Tensioning

Tensioning of tendons shall be carried out in a safe manner and in accordance with the following:

- (a) The stressing procedure shall ensure that the force in a tendon increases at a uniform time rate and that the force is transferred gradually to the concrete.
- (b) The prestressing force applied to the tendon shall be measured at the jack by measuring the jack pressure. The prestressing force shall be measured to an accuracy of $\pm 3\%$.
- (c) The tendon extension shall be measured.
- (d) A check shall be made for each tendon, on the correlation between the measured extension and the calculated extension derived from the prestressing force, using the load-elongation curves for the tendons and assumed friction values for the cable. Any disparity between the two figures greater than 10% of the calculated extension shall be investigated.
- (e) No stressing shall be carried out when the temperature of the surrounding air is lower than 0°C.

19.3.4.6 *Maximum jacking forces*

The maximum force to be applied to a tendon during the stressing operation shall not exceed—

- (a) for pretensioned tendons $0.80f_pA_p$;
- (b) for stress-relieved post-tensioned tendons $0.85f_pA_p$; or
- (c) for post-tensioned tendons not stress-relieved $0.75f_pA_p$.

19.3.4.7 *Grouting*

Ducts containing post-tensioned tendons shall be completely filled with grout, complying with Clause 19.1.8, as soon as practicable after stressing. Grouting shall not be carried out when the temperature of the surrounding air is lower than 5°C.

Precautions shall be taken to prevent corrosion for the tendons if the elapsed period prior to grouting is likely to exceed 4 weeks.

19.3.5 Construction requirements for unbonded tendons

Unbonded tendons shall not be permitted except in slabs on the ground. Where so used, the requirements of Clauses 19.3.4.1 to 19.3.4.6 shall apply, and the tendons shall be adequately protected against corrosion.

19.4 CONSTRUCTION REQUIREMENTS FOR JOINTS AND EMBEDDED ITEMS**19.4.1 Location of construction joints**

- (a) Construction joints shall be located to facilitate the placement of concrete in accordance with Clause 19.1.3.
- (b) Unless otherwise specified, a construction joint shall be made between the soffits of slabs or beams and their supporting columns or walls.
- (c) Where an interruption to the placing of concrete occurs such that the requirements of Clause 19.1.3(c) or 19.1.3(d) cannot be fulfilled, a construction joint complying with Clause 14.1.1 shall be made at an appropriate location.

19.4.2 Embedded and other items not shown in the drawings

Where an embedded item, driven fixing device, or hole is required but is not specifically shown in the drawings, or included in the specification, it shall be located so that the behaviour of the members is not impaired.

19.5 TOLERANCES FOR STRUCTURES AND MEMBERS**19.5.1 General**

For the purposes of the strength requirements of this Standard, the position of any point on the surface of a concrete member shall comply with Clause 19.5.2. More stringent tolerances may be required for reasons of serviceability, fit of components, or aesthetics of the structure.

For formed surfaces the tolerances given in AS 3610 take precedence, unless those in Clause 19.5.2 are more stringent. For unformed plane surfaces, the flatness tolerances and the methods for measuring them shall be detailed in the project specification, and shall be not greater than the relevant values given in Clause 19.5.2.

19.5.2 Tolerances for position and size of structures and members

19.5.2.1 Absolute position

The deviation from the specified position shall not exceed the following:

- (a) In plan, for a point on the surface of a column or wall at any floor level—
 - (i) in the first 20 storeys of any building 40 mm horizontally; and
 - (ii) for subsequent storeys, an increase of 15 mm horizontally for each additional 10 storeys or part thereof.
- (b) In elevation, for a point on the top surface of a floor or the soffit of a beam or slab adjacent to a column or wall 40 mm vertically.

19.5.2.2 Floor-to-floor plumb

In any column or wall, the deviation from plumb, measured floor-to-floor, shall not exceed 1/200 times the dimension between the floors or 10 mm, whichever is the greater.

19.5.2.3 Deviation from specified dimensions

The deviation from any specified height, plan, or cross-sectional dimension, shall not exceed 1/200 times, the specified dimension or 5 mm, whichever is the greater.

19.5.2.4 Deviation from surface alignment

The deviation of any point on a surface of a member, from a straight line joining any two points on the surface, shall not exceed 1/250 times the length of the line or 10 mm, whichever is the greater.

19.5.3 Tolerance on position of reinforcement and tendons

The deviation from the specified position of reinforcement and tendons shall not exceed the following:

- (a) For positions controlled by cover—
 - (i) in beams, slabs, columns and walls -5, +10 mm;
 - (ii) in slabs-on-ground -10, +20 mm; and
 - (iii) in footings cast in the ground -20, + 40 mm,
 where a positive value indicates the amount the cover may increase and a negative value indicates the amount the cover may decrease.
- (b) For positions *not* controlled by cover, namely—
 - (i) the location of tendons on a profile 5 mm;
 - (ii) the position of the ends of reinforcement 50 mm; and
 - (iii) the spacing of bars in walls and slabs and of fitments in beams and columns
10% of the specified spacing or 15 mm, whichever is greater.

19.6 FORMWORK

19.6.1 General

The materials, design and construction of formwork shall comply with AS 3610. Stripping of forms and removal of formwork supports from members cast in-situ shall comply with the requirements of Clause 19.6.2 where these are more stringent than the relevant requirements of AS 3610.

19.6.2 Stripping of forms and removal of formwork supports

19.6.2.1 *General*

The stripping of forms and the removal of formwork supports shall comply with the following:

- (a) Forms shall not be stripped or any formwork supports removed until the part of the member which will be left unsupported has attained sufficient strength to support, with safety and without detriment to its intended use, its own weight and any superimposed loads due to concurrent or subsequent construction works.
- (b) Removal of formwork supports shall be carried out in a planned sequence so that the concrete structure will not be subject to any unnecessary deformation, impact, or eccentric loading during the process.
- (c) Removal of formwork from vertical surfaces shall be carried out in accordance with Clause 19.6.2.2.
- (d) Stripping of forms, from the soffits of reinforced slabs and beams between formwork supports, shall be carried out in accordance with Clause 19.6.2.3 or Clause 19.6.2.4 as appropriate. Where backpropping is used, the procedure shall comply with the appropriate requirements of AS 3610.
- (e) Removal of formwork supports from the soffits of reinforced slabs or beams shall be carried out in accordance with—
 - (i) Clause 19.6.2.5 for members not supporting structures above; or
 - (ii) Clause 19.6.2.6 for multi-storey structures.
- (f) Stripping of forms and removal of formwork supports from prestressed beams and slabs shall be carried out in accordance with Clause 19.6.2.7.

19.6.2.2 *Removal of formwork from vertical surfaces*

Formwork shall not be removed from vertical surfaces unless the concrete in the member has achieved sufficient strength to withstand potential damage to its surfaces.

When formwork is stripped at less than 18 hours after casting, extra care shall be exercised to avoid surface damage during stripping.

19.6.2.3 *Stripping of soffit forms from reinforced beams and slabs where control samples are available*

Where control samples have been taken, cured and tested in accordance with Clause 19.6.2.8, soffit forms may be stripped from between the formwork supports of reinforced beams and slabs if—

- (a) the elapsed time between casting of the concrete and the commencement of stripping is greater than 3 days; and
- (b) the spans between the remaining formwork supports are such that the member will remain uncracked under the action effects of bending and shear due to the maximum concurrent or subsequent construction loads.

In determining whether sufficient curing time has elapsed, the design resistance of the member shall be taken as ϕR_u , where R_u is determined in accordance with the relevant clauses of Section 15, and the appropriate characteristic strength of the concrete is determined from the average strength of the control samples.

19.6.2.4 Stripping of soffit forms from reinforced slabs of normal-class concrete

For reinforced slabs of normal-class concrete, for which an early-age strength has been specified and which are continuous over formwork supports, the period of time between casting of the concrete and the commencement of stripping of the forms between formwork supports shall be not less than that given in Table 19.6.2.4 for the appropriate average ambient temperature over the period. The periods given in the table shall be increased if—

- (a) $L_s / D > 280 / \sqrt{(D+100)}$
- (b) the superimposed construction load is greater than 2.0 kN/m²; or
- (c) the average ambient temperature over the period is less than 5°C, in which case the periods shall be increased by half a day for each day the daily average temperature was between 2°C and 5°C, or by a whole day for each day the daily average temperature was below 2°C.

TABLE 19.6.2.4

STRIPPING OF FORMWORK FROM REINFORCED SLABS CONTINUOUS OVER FORMWORK SUPPORTS

Average ambient temperature over the period (<i>T</i>) °C	Period of time before stripping <i>normal-class</i> concrete with specified early-age strength days
$T > 20$	4
$20 \geq T > 12$	6
$12 \geq T > 5$	8

19.6.2.5 Removal of formwork supports from reinforced members not supporting structures above

For the purpose of determining the minimum period before any undisturbed supports or backprops can be removed from the soffits of reinforced members not supporting structures above, it may be assumed that the requirements of Clause 19.6.2.1(a) will be satisfied if either—

- (a) it can be demonstrated by calculations, based on known or specified early-age strengths that, at the time of removal, the concrete has gained sufficient strength so that the degree of cracking or deformation, which that will occur then or subsequently, is not greater than that which would occur if the design serviceability load were applied to the member when the concrete has attained its required design strength; or
- (b) in the absence of any early-age strength data, the period of time is not less than that given in Table 19.6.2.5 for the appropriate average ambient temperature over the period. The periods given in Table 19.6.2.5 shall be increased if—
 - (i) the superimposed construction load is greater than 2.0 kN/m²; or
 - (ii) the average ambient temperature is less than 5°C, in which case the periods shall be increased by half a day for each day the daily average temperature was between 2°C and 5°C, or by a whole day for each day the daily average temperature was below 2°C.

TABLE 19.6.2.5
REMOVAL OF FORMWORK SUPPORTS FROM SLABS AND BEAMS NOT
SUPPORTING STRUCTURES ABOVE

Average ambient temperature over the period (T) °C	Period of time before removal of all formwork supports from reinforced members days
$T > 20$	12
$20 \geq T > 12$	18
$12 \geq T > 5$	24

19.6.2.6 *Removal of formwork supports from reinforced members in multistorey structures*

In multistorey structures, the number of storeys, including the lowest storey, which are to remain supported by formwork at any one time and the maximum spacing of the formwork supports in any storey, shall be calculated on the basis of the relevant properties of the concrete in each floor at that time and the interaction between the formwork supports and the concrete structure.

Where removal of formwork supports from a storey will result in the floors above being supported mainly by formwork and suspended concrete construction, all supported and supporting floors and beams shall be checked by calculation for cracking and deflection under the resulting loads. Removal of formwork supports from that storey may then be permitted only if the magnitude of the cracks and deflections so calculated will not impair the strength or serviceability of the completed structure.

No undisturbed supports or backprops shall be removed within 2 days of the placing of any slab directly or indirectly supported by such supports.

19.6.2.7 *Stripping of forms and removal of supports from soffits of prestressed concrete slabs and beams*

Formwork shall not be stripped and formwork supports not removed from the soffits of prestressed concrete slabs or beams until the strength of the concrete in the member and the number of tendons stressed are such as to provide the necessary strength to carry the dead and construction loads.

19.6.2.8 *Control tests*

If specified, control test-samples of the concrete shall be taken where it is intended that removal of formwork or the stressing of tendons will occur before the concrete has attained the strength assumed in the design of the member.

Control test-samples shall be taken at a minimum frequency of one sample for each 50 m³, or part thereof, of a concrete grade placed on any one day and the sample specimens stored and cured under conditions similar to those of the concrete in the work.

At least two specimens from each grade shall be tested for strength at the desired time of stripping or stressing and the strength of the concrete at that age assessed on the basis of the average strength of the specimens.

APPENDIX A

ADDITIONAL REQUIREMENTS FOR STRUCTURES SUBJECT TO EARTHQUAKE ACTIONS

(Normative)

A1 SCOPE

This Appendix sets out additional minimum requirements for concrete structures and structural members that are required to be designed and detailed for earthquake actions.

This Appendix applies to concrete structures and structural members that form the whole or part of structures or buildings to which AS 1170.4 applies.

A2 EARTHQUAKE-RESISTANCE REQUIREMENTS

A2.1 General

A concrete structure or member requiring design for earthquake actions shall contain reinforcement, or tendons, or both, and shall be designed, detailed and constructed to comply with all the relevant Sections of this Standard, the additional requirements of this Appendix and AS 1170.4.

A2.2 Earthquake design category

The earthquake Design Category of a structure shall be determined in accordance with AS 1170.4.

A3 DEFINITIONS

For the purpose of this Appendix, relevant definitions given in AS 1170.4 are repeated below.

NOTE: Definitions marked with an asterisk have been modified to suit their application in this Appendix.

A3.1 Acceleration coefficient

An index related to the expected severity of earthquake ground motion.

A3.2 Bearing wall system

A structural system with loadbearing walls providing support for all or most of the vertical loads and shear walls or braced frames providing the horizontal earthquake resistance.

A3.3 Boundary elements

Portions along discontinuous wall edges strengthened by longitudinal and transverse reinforcement.

NOTE: Boundary elements do not necessarily require an increase in the thickness of the wall.

A3.4 Braced frame

An essentially vertical truss, or its equivalent, designed to resist horizontal earthquake forces. Truss members are subjected primarily to axial forces.

A3.5 Building frame system

A structural system in which an essentially complete space frame supports the vertical loads, and shear walls or braced frames provide the horizontal earthquake resistance.

A3.6 Dual system

A structural system in which an essentially complete space frame provides support for the vertical loads and at least a quarter of the prescribed horizontal earthquake forces. The total horizontal earthquake resistance is provided by the combination of the moment frame and shear walls or braced frames, in proportion to their relative rigidities.

A3.7 Ductility

The ability of the structure or element to undergo repeated and reversing inelastic deflections beyond the point of first yield while maintaining a substantial proportion of its initial load-carrying capacity.

A3.8 Earthquake design category*

A category assigned to a structure, in accordance with AS 1170.4, based on its structure classification, acceleration coefficient and site factor.

A3.9 Earthquake resisting system

That part of the structural system, which is considered in the design to provide resistance to the earthquake forces.

A3.10 Intermediate moment resisting frame (IMRF)*

A concrete space frame, designed in accordance with this Standard, in which members and joints are capable of resisting forces by flexural as well as axial action, and which comply with the specific earthquake detailing requirements of this Appendix.

A3.11 Loadbearing wall

A wall providing support for vertical loads in addition to its own weight.

A3.12 Moment resisting frame system

A structural system in which an essentially complete space frame supports the vertical loads and the total prescribed horizontal earthquake forces by the flexural action of members.

A3.13 Non-loadbearing wall*

A wall which does not provide support for vertical loads other than its own weight.

A3.14 Ordinary moment resisting frame (OMRF)*

A concrete space frame, designed in accordance with this Standard in which members and joints are capable of resisting forces by flexural as well as axial action but which do not comply with the specific detailing requirements of this Appendix.

A3.15 Shear wall

A wall designed to resist horizontal earthquake forces acting in the plane of the wall. A shear wall can be either loadbearing or non-loadbearing.

A3.16 Space frame

A three-dimensional structural system composed of interconnected members, other than loadbearing walls, which is capable of supporting vertical loads and may also provide horizontal resistance to earthquake forces.

A3.17 Special moment resisting frame (SMRF)*

A concrete space frame, designed in accordance with this Standard, in which members and joints are capable of resisting forces by flexural as well as axial action and are detailed, in accordance with the earthquake detailing requirements of ACI 318M-02 Chapter 21, for regions of high seismic risk.

A1

A3.18 Structure

An assemblage of members designed to support gravity loads and resist horizontal forces and may be either a building structure or a non-building structure.

A3.19 Structural base

The level at which the earthquake ground motions are considered to be imparted to the structure, or the level at which the structure as a dynamic vibrator is supported.

A3.20 Structure classification *

A classification assigned to a structure, in accordance with AS 1170.4, based on its use.

A3.21 Vertical load-carrying frame

A space frame designed to carry all vertical loads.

A4 EARTHQUAKE DESIGN LOAD

The earthquake design load shall be determined from AS 1170.4 for the load combination applicable to the relevant limit state.

A5 GENERAL DESIGN REQUIREMENTS

General design and detailing requirements shall be in accordance with this Standard and AS 1170.4 where required.

A6 DOMESTIC STRUCTURES

A6.1 Design categories H1 and H2

In earthquake Design Categories H1 and H2, reinforced or prestressed members, designed and detailed in accordance with this Standard, shall be regarded as ductile. Concrete structures in these Design Categories are not required to be specifically designed or detailed for resistance to earthquake loads.

A6.2 Design category H3

In earthquake Design Category H3, reinforced or prestressed members, which are cast in situ, shall be regarded as ductile if designed, detailed and constructed in accordance with this Standard.

Assemblages of precast elements and any combination of concrete members supported by other materials shall be assessed as being ductile, or in terms of the ductility of the connections between them and the ductility of their supports.

NOTE: For non-structural components (e.g. chimneys, parapets) see AS 1170.4.

A7 GENERAL STRUCTURES IN DESIGN CATEGORY A

In earthquake Design Category A, general structures composed of reinforced or prestressed members shall be regarded as ductile if designed, detailed and constructed in accordance with this Standard. Concrete structures in this Design Category are not required to be specifically designed or detailed for resistance to earthquake loads.

NOTE: Any reinforced or prestressed concrete member used as a non-structural component in a Design Category A building may be regarded as being ductile.

A8 GENERAL STRUCTURES IN DESIGN CATEGORY B

A8.1 General

In earthquake Design Category B, general structures composed of reinforced or prestressed members shall be regarded as ductile if they are designed, detailed and constructed in accordance with this Standard and the additional detailing requirements, if any, of this Appendix.

A8.2 Regular structures

Regular structures of reinforced or prestressed concrete in earthquake Design Category B are not required to be specifically designed or detailed for resistance to earthquake loads.

A8.3 Irregular structures

Irregular structures of reinforced or prestressed concrete in earthquake Design Category B shall be designed for resistance to earthquake loads determined in accordance with AS 1170.4, as appropriate for the particular structural system used and detailed in accordance with this Standard.

A9 GENERAL STRUCTURES IN DESIGN CATEGORIES C, D AND E

A9.1 General

For general structures composed of reinforced or prestressed members in earthquake Design Categories C, D and E, the design action effects determined in accordance with AS 1170.4 are dependent on the structural system adopted and the type of member being considered. In order to meet the relevant level of ductility, the additional detailing requirements of Paragraphs A10 to A13 of this Appendix, as appropriate for the particular structural system, shall be satisfied.

A9.2 Exterior cladding elements

Reinforced or prestressed members which are attached to, or enclose, the exterior of a structure (e.g. non-structural cladding panels) in earthquake Design Categories C, D and E, shall be capable of accommodating movements of the structure resulting from the relevant earthquake actions as follows:

- (a) All connections and panel joints shall allow for the expected relative movement between floors in adjoining storeys.
- (b) Connections shall have sufficient ductility and rotational capacity to preclude non-ductile failure of the connection.

A10 BEARING WALL SYSTEMS—Shear walls or braced frames

Reinforced or prestressed concrete shear walls or braced frames in a bearing wall system shall be regarded as ductile if they are designed, detailed and constructed in accordance with this Standard. No additional detailing in accordance with this Appendix is required.

A11 BUILDING FRAME SYSTEMS

A11.1 General

In building frame systems, any reinforced or prestressed shear wall, or reinforced braced frame, shall be regarded as ductile if it satisfies the detailing requirements specified in Paragraph A11.2 or A11.3 respectively, in addition to the detailing requirements of this Standard.

A11.2 Shear walls

A11.2.1 General

Shear walls shall be provided with boundary elements in accordance with Paragraph A11.2.3. For structures of not more than four storeys above their structural base and where boundary elements are required, an integrally cast column, or additional edge reinforcement consisting of two N16 or four N12 bars, shall be deemed to satisfy this requirement.

A11.2.2 Reinforcement

The reinforcement ratio (p_w) in the vertical and horizontal direction shall be not less than 0.0025. The reinforcement shall be divided equally between the two wall faces if—

- (a) the wall thickness is greater than 200 mm; or
- (b) the design horizontal shear force on the cross-section is greater than $(A_g f'_c)/6$.

Wall reinforcement terminating in footings, columns, slabs, or beams shall be anchored to develop the yield stress in the reinforcement at the junction of the wall with the terminating member.

A11.2.3 Boundary elements

In any storey, boundary elements shall be provided at discontinuous edges of shear walls and around openings through them if—

- (a) the vertical reinforcement within the storey height is not laterally restrained in accordance with Clause 10.7.3; and
- (b) the calculated extreme fibre compressive stress in the wall exceeds $0.15 f'_c$.

The stress referred to in Item (b) shall be calculated using the design action-effects for the strength limit state, a linear-elastic strength model and the gross cross-section properties of the wall.

Where boundary elements are required, the horizontal cross-section of the wall shall be treated as an I-beam in which the boundary elements are the flanges and the section of wall between them is the web. Restraint of the longitudinal reinforcement in boundary elements shall comply with Clause 10.7.3 of this Standard or, if the extreme fibre compressive stress calculated as above exceeds $0.2 f'_c$, with Paragraph A11.3.2 of this Appendix.

A11.3 Reinforced braced frames

A11.3.1 General

Bracing members of a braced frame shall be designed as columns in accordance with Section 10 of this Standard, or as tension members as appropriate.

Connections between members in braced frames shall be designed to develop a strength in excess of the strength of each connected member.

A11.3.2 Restraint of longitudinal reinforcement

In the members of a reinforced braced frame, the longitudinal reinforcement shall be restrained by lateral reinforcement throughout the full length of the member as follows:

- (a) Where helices are used, the volume of the steel in the helix divided by the volume of concrete bounded by it, per unit length of member, shall be not less than $0.12 (f'_c / f_{sy,f})$
- (b) Where closed ties are used, the total cross-sectional area of the ties, A_{sv} , shall be not less than—
 - (i) $0.30 s y_1 (A_g / A_c - 1) (f'_c / f_{sy,f})$; or
 - (ii) $0.09 s y_1 (f'_c / f_{sy,f})$;
 whichever is greater

where

- s = centre-to-centre spacing of ties
- y_1 = the larger core dimension
- A_g = the gross cross-section area of the member
- A_c = the cross-section area of the core measured over the outside of the ties

except that Item (b)(i) does not apply if ϕN_{uo} for the core (concrete + reinforcement) is greater than N^* .

- (c) Closed ties in accordance with Item (b) shall be used singly or in sets spaced at not more than 100 mm centres, or one-quarter of the minimum cross-section dimension, whichever is smaller.

Supplementary ties, of the same diameter as the closed ties, consisting of a straight bar with 135° minimum hook at each end, may be considered as part of a closed tie if they are spaced at not more than 350 mm centres and secured with the closed tie to the longitudinal bars.

A12 MOMENT RESISTING FRAME SYSTEMS

A12.1 General

Moment resisting frames of reinforced and prestressed concrete shall be regarded as ductile if—

- (a) the detailing requirements specified in Paragraphs A12.2 to A12.4, as appropriate, are satisfied, in addition to the detailing requirements of this Standard; and
- (b) only Class N steel or prestressing tendons are used as flexural reinforcement.

Rigid elements may be incorporated into a moment-resisting frame, provided it is shown that the action or failure of these elements will not impair the capacity of the frame to resist horizontal or vertical forces.

A12.2 Ordinary moment resisting frames (OMRF)

No additional detailing in accordance with this Appendix is required for OMRFs.

A12.3 Intermediate moment resisting frames (IMRF)

A12.3.1 General

Reinforced IMRFs shall be regarded as ductile if they satisfy the detailing requirements of Paragraphs A12.3.2 to A12.3.5 and prestressed IMRFs if they satisfy the detailing requirements of Paragraph A12.3.6 to A12.3.9, in addition to the detailing requirements of this Standard.

A12.3.2 Beams

A12.3.2.1 Longitudinal reinforcement

Beams shall be provided with longitudinal reinforcement complying with the following:

- (a) The top and bottom face of the beam shall be continuously reinforced.
- (b) The area of reinforcement provided in a span shall be such that—
 - (i) the positive-moment strength at a support face is not less than one-third of the negative-moment strength provided at that face of the support; and
 - (ii) neither the negative nor the positive-moment strength at any section along the member length is less than one-fifth of the maximum moment strength provided at the face of either support.

- (c) Longitudinal reinforcement shall be continuous through intermediate supports. When framing into external columns, the longitudinal reinforcement shall be extended to the far face of the confined region and anchored to develop the yield strength of the reinforcement at the span face of the support.
- (d) Lapped splices in longitudinal reinforcement, located in a region of tension or reversing stress, shall be confined by at least two closed ties at each splice.

A12.3.2.2 *Shear reinforcement*

Beams shall be provided with shear reinforcement complying with the following requirements:

- (a) Shear reinforcement shall be perpendicular to the longitudinal reinforcement; be provided throughout the length of the member; have at least two legs and have a maximum spacing of $0.5D$.
- (b) The area of shear reinforcement, A_{sv} , shall not be less than $0.5b_w s/f_{sv.f}$.
- (c) Over a distance of at least $2D$ from the face of a support, shear reinforcement shall be closed ties, with the first tie located 50 mm from the support face. These closed ties shall be spaced at centres not greater than $0.25d_o$, $8d_b$, $24d_f$ or 300 mm, whichever is least—

where

d_b = the diameter of the smallest longitudinal bar enclosed by the tie; and

d_f = the diameter of the bar forming the tie.

A12.3.3 *Slabs*

A12.3.3.1 *General*

Slabs shall comply with Paragraphs A12.3.2.1 (a), (b) and (c). Two-way flat slabs forming part of a moment-resisting frame shall also comply with Paragraph A12.3.3.2.

A12.3.3.2 *Reinforcement detailing in flat slabs*

Reinforcement in flat slabs shall be located and anchored in accordance with the following:

- (a) All reinforcement, which is provided to resist the portion of the slab moment transferred to the support, shall be placed within the column-strip defined in Clause 7.1.2.
- (b) A proportion of the reinforcement required by Item (a) above shall be evenly distributed in a width of slab between planes that are one and one-half times the thickness of the slab or drop panel beyond faces of the column or capital.

The proportion to be distributed is given by—

$$\frac{1}{1 + 2/3 \sqrt{\left(\frac{b_l + d_o}{b_t + d_o}\right)}}$$

or 0.5, whichever is greater.

where

b_l = size of rectangular, or equivalent rectangular, column, capital, or bracket, measured in the direction of the span for which moments are being determined

b_t = size of rectangular, or equivalent rectangular, column, capital, or bracket, measured transverse to the direction of the span for which moments are being determined

- (c) Not less than one-quarter of the top reinforcement at the support in the column strip shall be continuous throughout the span.
- (d) Continuous bottom reinforcement in the column strip shall be not less than one-third of the area of the top reinforcement in the column strip at the support.
- (e) Not less than one-half of all bottom reinforcement at midspan shall be continuous through the support for the distance required to develop its yield strength at the face of the support.
- (f) At discontinuous edges of the slab, all top and bottom reinforcement at a support shall be capable of developing its yield strength at the face of the support.

A12.3.4 *Columns*

At each end of the clear height of a column within a storey, the longitudinal reinforcement shall be restrained by closed ties for a distance from the end equal to the greater of the maximum dimension of the column cross-section, or one sixth of the least clear height between consecutive flexural members framing into it.

The spacing of the closed ties shall be not greater than required by Paragraph A12.3.2.2(c), with the first tie located at half this spacing from the face of the relevant support. The cross-sectional area of the ties shall be sufficient to satisfy the shear requirements for the column but not less than required by Paragraph A11.3.2(b).

A12.3.5 *Column joints*

Joints between columns and flexural members framing into them shall be confined by closed ties throughout the depth of the joint.

The spacing of the closed ties shall be not greater than required by Paragraph A12.3.2.2(c) and the cross-sectional area of the ties not less than required by Paragraph A11.3.2 except that the cross-sectional area may be reduced to half this value for the depth of the shallowest of those members framing into the column from at least two directions at right angles.

A12.3.6 *Prestressed IMRFs*

A12.3.6.1 *General*

Beams containing tendons shall satisfy the detailing requirements of Paragraphs A11.3.2 and A12.3.7.

Tendons shall be fully bonded and shall be detailed so that anchorages or transmission lengths are not placed—

- (a) within beam-column joint cores; or
- (b) to lie along critical shear planes.

A12.3.6.2 *Connections*

Connections between members shall—

- (a) have a strength greater than that of the members being joined;
- (b) have adequate ductility to withstand the calculated deformations; and
- (c) be designed to fail in a ductile manner under reversals of loading.

A12.3.6.3 *Supports*

Supports shall be designed so that horizontal or vertical displacements, or both, will not cause the failure or collapse of any part of the structure.

A12.3.7 Prestressed beams

Prestressed beams shall satisfy the following:

- (a) The quantity of tensile steel (tensioned plus untensioned) shall be such that the flexural strength of any beam section is greater than $1.1(M_{uo})_{min.}$ at that section.
- (b) Flexural reinforcement shall comply with Paragraph A12.3.2.
- (c) Unless tensile steel is provided at various depths throughout the section and the depth of the neutral axis at the design moment is less than 0.22 times the overall depth of the section, the quantity of tensile steel (tensioned and non-tensioned) shall be such that—

A1

$$(A_{pt} f_{py} + A_{st} f_{sy}) / (bdf'_c) \leq 0.2$$

- (d) Shear reinforcement consisting of closed ties shall be provided to carry the total design shear force for a distance of $2D$ from the face of the support. The closed ties shall be of not less than 6 mm bar diameter, with a maximum spacing of 100 mm or $d/4$, whichever is the lesser.

A12.3.8 Prestressed columns

The flexural strength of any prestressed column section shall be greater than $1.1(M_{uo})_{min.}$ at that section, after allowance for the effect of axial loads. The columns shall also comply with Paragraph A12.3.4 and Paragraph A12.3.7(d).

A12.3.9 Beam-column joints

Beam-column joints shall satisfy the following:

- (a) At least one prestressing tendon in the beam shall be located in the mid-depth of the beam at the joint.
- (b) All joints between columns and prestressed beams shall be confined by transverse column reinforcement throughout the joint. Such reinforcement shall be as required by Paragraph A12.3.4.
- (c) The interfaces at connections between precast members at beam column joints shall be roughened to ensure good shear transfer and the retention of any jointing material after cracking.

A12.4 Special moment resisting frames (SMRF)

A1

Special moment resisting frames shall be detailed in accordance with the special provisions for seismic design in regions of high seismic risk, as specified in ACI 318M–02 Chapter 21.

A13 DUAL SYSTEMS**A13.1 General**

Dual systems of concrete construction shall be composed of one of the following combinations of structural framing elements:

- (a) An intermediate moment resisting frame and a shear wall.
- (b) An intermediate moment resisting frame and a braced frame.
- (c) A special moment resisting frame and a shear wall.
- (d) A special moment resisting frame and a braced frame.

Dual systems shall be regarded as ductile if the components satisfy the requirements specified in Paragraphs A13.2 to A13.5, in addition to the detailing requirements of this Standard.

A13.2 IMRF and shear wall

The intermediate moment resisting frame shall comply with Paragraph A12.3, and the shear wall with Paragraph A11.2.

A13.3 IMRF and braced frame

The intermediate moment-resisting frame shall comply with Paragraph A12.3, and the braced frame with Paragraph A11.3.

A13.4 SMRF and shear wall

A1 | The special moment resisting frame shall comply with Paragraph A12.4, and the shear wall with the relevant special provisions for seismic design specified in ACI 318M–02.

A13.5 SMRF and braced frame

A1 | The special moment resisting frame shall comply with Paragraph A12.4, and the braced frame with the relevant special provisions for seismic design specified in ACI 318M–02.

APPENDIX B
TESTING OF MEMBERS AND STRUCTURES
(Normative)

B1 GENERAL

This Appendix applies to the testing of a structure or of a prototype, to demonstrate compliance with the strength and serviceability requirements of this Standard. In addition, a procedure is set out to demonstrate routine compliance for similar units manufactured following prototype testing. Methods for testing hardened concrete in place are also detailed. All testing shall be undertaken by persons competent in, and with appropriate expertise for, performing such tests.

B2 TESTING OF MEMBERS

B2.1 Purpose of testing

Structures designed by calculation in accordance with other parts of this Standard are not required to be tested. Tests can be accepted as an alternative to calculation (prototype testing), or may become necessary in special circumstances (proof testing), in order to satisfy the requirements of Clause 2.3 with respect to strength and Clause 2.4 with respect to serviceability.

Where testing is necessary, elements of structures or whole structures shall be either—

- (a) proof tested in accordance with Paragraph B3, to ascertain the structural characteristics of an existing member or structure; or
- (b) prototype tested in accordance with Paragraph B4, to ascertain the structural characteristics of a particular class of member, which are nominally identical to the elements tested.

B2.2 Test set-up

All measuring equipment shall be chosen and calibrated to suit the range of measurements anticipated, in order to obtain measurements of the required precision. Care shall be exercised to ensure that no artificial restraints are applied to the test specimen. All necessary precautions shall be taken such that in the event of collapse of any part of a structure being tested, the risk to life is minimized and the collapse will not endanger the safety of the structure being tested (for tests on members) and/or adjacent structures.

B2.3 Test load

The test load shall simulate 100% of the design loads for the limit states for strength and serviceability, as appropriate. The test load shall be applied gradually at a rate as uniform as practicable and without impact. The distribution and duration of forces applied in the test shall be representative of those forces to which the structure is deemed to be subject under the requirements of this Standard.

B2.4 Test deflections

The maximum vertical deflections of each test specimen shall be measured with respect to an appropriate datum. Deflections shall, as a minimum requirement, be recorded at the following times:

- (a) Immediately prior to the application of the test load.
- (b) Incrementally during the application of the test load.

- (c) Immediately the full test load has been applied.
- (d) Immediately prior to removing the test load.
- (e) Immediately after the removal of the test load.

B3 PROOF TESTING

B3.1 Test procedures

A proof test shall be conducted according to the following procedures:

- (a) Before applying any load, record the original position of the members involved.
- (b) Apply the test load as determined from Section 3, for the relevant limit state.
- (c) Maintain the test load for the necessary period as stated in Paragraph B3.2.
- (d) Remove the test load.

B3.2 Criteria for acceptance

Criteria for acceptance shall be as follows:

- (a) *Acceptance for strength* The test structure or element shall be deemed to comply with the requirements for strength if it is able to sustain the strength limit state test load for at least 24 h without incurring any significant damage such as spalling or excessive cracking.
- (b) *Acceptance for deflection* The test structure or element shall be deemed to comply with the requirements for serviceability if it is able to sustain the serviceability test load for a minimum of 24 h without exceeding the appropriate serviceability limits.

A1 | Appropriate deflection limits for beams and slabs shall be determined using Clause 2.4.2 and the deflections calculated taking into account long-term and short-term effects allowing for the age and loading history of the structure.

B3.3 Damage incurred during test

The test specimen shall be regularly inspected, to determine the nature and extent of any damage incurred during the test. The effects of the damage shall be considered and the test disbanded if collapse seems likely. At the completion of the test, appropriate repairs to damaged parts shall be carried out.

B3.4 Test reports

A report shall be prepared, which shall contain, in addition to the test load and serviceability criteria records, a clear description of the test set-up, including the methods of supporting and loading the members, the method of measuring deflections, crack-widths, and so on, and any other relevant data. The report shall also contain a statement as to whether or not the structure, substructure or members tested satisfied the relevant acceptance criteria in Paragraph B3.2, as appropriate.

B4 PROTOTYPE TESTING

B4.1 Construction of prototypes

The prototype shall be constructed from materials that comply with this Standard in accordance with the requirements of the manufacturing specification for the element or member.

B4.2 Number of prototypes

The number of prototypes to be tested shall be selected so that statistically reliable estimates of the behaviour of the member at relevant limit state values can be determined from the results of the testing. No fewer than two prototypes shall be tested. More than one loading combination and more than one limit state condition may be applied to a prototype.

B4.3 Test load

The test load shall be applied gradually until the total load on the prototype is equal to the design load for the strength limit state as determined from Section 3, multiplied by the relevant factor given in Table B4.3. This factor shall be selected with respect to the expected coefficient of variation in the parameters that affect the strength and the sample size selected for the testing program, unless a reliability analysis shows that a different value is appropriate.

The total load for each prototype used to assess serviceability shall be the design load for the serviceability limit state as determined from Section 3 multiplied by a factor of 1.2.

TABLE B4.3
FACTOR TO ALLOW FOR VARIABILITY IN PRODUCTION OF UNITS

No of similar units to be tested	Expected coefficient of variation		
	10%	20%	30%
2	1.3	1.7	2.3
3	1.3	1.6	2.1
5	1.2	1.5	1.8
10	1.1	1.3	1.5

NOTE: Intermediate values may be obtained by linear interpolation. The above values are based on a target safety index of 3.0 for a confidence level of 90%.

B4.4 Test procedure

The method of applying the test load to the prototype shall reflect the most adverse conditions expected to occur during construction and the in-service condition.

A prototype test shall be conducted according to the following procedure:

- (a) Before applying any load, record the original position of the members in the test specimen.
- (b) Apply the test load for the relevant limit state, as determined from Paragraph 4.3.
- (c) Maintain the test load for the necessary period, as stated in Paragraph B4.5.
- (d) Remove the test load.
- (e) Inspect and record the prototype for damage, spalling, cracking and any other relevant observations.

B4.5 Criteria for acceptance

The units represented by the prototypes shall be deemed to comply with this Standard for serviceability and strength where Item (a) is satisfied and Item (b) or Item (c) is satisfied, as follows:

- (a) *Variability* Production units shall be similar in all respects to the prototypes tested, and variability of units shall not be greater than the expected variability selected in Table B4.3.

- (b) *Acceptance for strength* The test prototype shall be deemed to comply with the requirements for strength if it is able to sustain the strength limit state test load for at least 5 min without incurring any significant damage, such as spalling or excessive cracking.
- (c) *Acceptance for serviceability* The test prototype shall be deemed to comply with the requirement for serviceability if it is able to sustain the serviceability test load for a minimum period of 1 h without exceeding the serviceability limits appropriate to the member. Deflection limits shall be determined using Clause 2.4.2, taking into account only short-term effects.

A1

Qualitative indicators for the parameters affecting strength shall be determined for expected variability during production. These indicators shall be routinely monitored and measured in manufactured units and used to assess the expected coefficient of variation. Alternatively, manufactured units shall be routinely tested to failure, to determine the coefficient of variation.

B4.6 Test reports

A report shall be prepared in accordance with Paragraph B3.4. The report shall also contain a statement as to whether or not the prototypes tested satisfied the relevant acceptance criteria in Paragraph B4.5 as appropriate.

B5 QUALITY CONTROL

B5.1 Application

This Paragraph applies to the assessment of a group of units that are part of a production run of similar units. Paragraphs B5.2, B5.3 and B5.4 identify three methods to routinely assess production. One of these methods shall be nominated by the manufacturer as the means of demonstrating that the manufactured group is similar to the tested prototypes. A routine examination shall include the determination of the variability in a production run by relating key indicators in the sample to the previously performed prototype testing and the application of a test load to each sample, as appropriate.

B5.2 Statistical sampling

A sampling plan, in accordance with AS 1199, shall be established for the routing inspection and testing of a produced batch. Sampling shall be undertaken in accordance with this plan and the selected specimens shall be routinely tested to ensure compliance with this Appendix is maintained.

For concrete specified by strength, the methods of production and assessment, taken together, shall provide a reliable operating characteristic curve so that—

- (a) concrete with a proportion defective of 0.05 has a probability of acceptance of not less than 50%; and
- (b) concrete with proportion defective of 0.30 has a probability of rejection of not less than 98%.

B5.3 Product certification

Independent assurance of the claim by a manufacturer or contractor of batch consistency shall be permitted, to ascertain whether a production run or application routinely complies with the requirements of this Appendix. The certification shall meet the criteria described in HB18.28 in order that effective quality planning to control production is achieved.

B5.4 Quality system

Confidence in routine assessment of production shall be achieved where the manufacturer or contractor can demonstrate that an audited and registered quality management system complying with the requirements of the appropriate or stipulated Australian or international Standard for a quality system is in place.

Such a system shall include a quality or inspection and test plan, to ensure product conformity.

B6 TESTING OF HARDENED CONCRETE IN PLACE

B6.1 Application

This Paragraph applies to the assessment of the strength and other properties of hardened concrete in place by non-destructive testing, by testing of samples cut from representative test panels, or samples cut from members.

B6.2 Preparation of samples

Samples tested shall be representative of the concrete under investigation. Prior to testing, surfaces shall be cleaned to remove oil, laitance, curing compounds and surface treatments.

Where required, test panels shall be made of concrete that is identical in composition and which is placed, compacted and cured in a manner similar to concrete used in the member. Dimensions of test panels shall be such that at least three representative samples can be cut from each panel. Test samples of standard dimensions shall be obtained from the test panels by coring or sawing.

B6.3 Non-destructive testing

Non-destructive testing including impact or rebound hammer, ultrasonic pulse velocity, pullout and abrasion testing, or a combination of techniques, may be used to compare the properties of concrete under investigation with that of a representative sample of known quality. In particular, comparable concrete should be of similar maturity, curing history and mix composition. Alternatively, where specified, values obtained by non-destructive tests may be used directly to assess some properties of concrete.

The method of testing and assessment shall be specified and carried out in accordance with internationally recognized procedures.

NOTE: Combined non-destructive techniques have been found to substantially improve the order of accuracy of the estimated values compared with those obtained from testing by a single method.

B6.4 Tests on samples taken from the structure

B6.4.1 Test requirements

Taking and testing of cores and beams from members and sample panels shall comply with the following:

- (a) Core and beam locations shall be selected so as to minimize any consequent reduction of strength.
- (b) The cores and beams shall be representative of the whole of the concrete concerned and in no case shall less than three samples be tested.
- (c) Cores and beams shall be examined visually before and after testing, to assess the proportion and nature of any voids, cracks and inclusions present. These factors shall be considered in the interpretation of the test results.

- (d) Cores shall be taken and tested for compressive strength in accordance with AS 1012.14, beams shall be taken in accordance with ASTM C42 and tested for flexural strength in accordance with AS 1012.11, and shall be tested dry unless the concrete concerned will be more than superficially wet in service. The density of cores and beams shall be determined in accordance with AS 1012.12, in the same condition as applicable to testing for compressive strength using Method 1 or Method 2 by sealing or wrapping samples where appropriate.

B6.4.2 *Interpretation of results*

The strength of the concrete in the member may be estimated—

- (a) as 1.15 times the average strength of the cores and beams; or
- (b) by using test data from cores or beams taken from another member for which the strength of the concrete is known.

APPENDIX C

REFERENCED DOCUMENTS

(Normative)

The following documents are referred to in this Standard:

AS

- | | |
|---------|---|
| 1012 | Methods of testing concrete |
| 1012.1 | Method 1: Sampling fresh concrete |
| 1012.3 | Method 3: Determination of properties related to the consistency of concrete |
| 1012.4 | Method 4: Methods for the determination of air content of freshly mixed concrete |
| 1012.9 | Method 9: Method for the determination of compressive strength of concrete specimens |
| 1012.10 | Method 10: Determination of indirect tensile strength of concrete cylinders ('Brazil' or splitting test) |
| 1012.11 | Method 11: Determination of the modulus of rupture |
| 1012.12 | Method 12: Method for the determination of mass per unit volume of hardened concrete |
| 1012.13 | Method 13: Determination of the drying shrinkage of concrete for samples prepared in the field or in the laboratory |
| 1012.14 | Method 14: Method for securing and testing cores from hardened concrete for compressive strength |
| 1012.16 | Method 16: Determination of creep of concrete cylinders in compression |
| 1012.17 | Method 17: Determination of the static chord modulus of elasticity and Poisson's ratio of concrete specimens |
| 1170 | Minimum design load on structures |
| 1170.1 | Part 1: Dead and live loads and load combinations |
| 1170.2 | Part 2: Wind loads |
| 1170.3 | Part 3: Snow loads |
| 1170.4 | Part 4: Earthquake loads |
| 1199 | Sampling procedures and tables for inspection by attributes |
| 1302 | Steel reinforcing bars for concrete |
| 1303 | Steel reinforcing wire for concrete |
| 1304 | Welded wire reinforcing fabric for concrete |
| 1310 | Steel wire for tendons in prestressed concrete |
| 1311 | Steel tendons for prestressed concrete—7-wire stress-relieved steel strand for tendons in prestressed concrete |
| 1313 | Steel tendons for prestressed concrete—Cold-worked high-tensile alloy steel bars for prestressed concrete |
| 1379 | Specification and supply of concrete |
| 1391 | Methods for tensile testing of metals |
| 1476 | Metric wood screws |
| 1478 | Chemical admixtures for concrete, mortar and grout |
| 1478.1 | Part 1: Admixtures for concrete |
| 1530 | Methods for fire tests on building materials, components and structures |
| 1530.4 | Part 4: Fire-resistance tests of elements of building construction |
| 1554 | Structural steel welding |
| 1554.3 | Part 3: Welding of reinforcing steel |

- AS
 1768 Lightning protection
 2193 Methods for calibration and grading of force-measuring systems of testing machines
 2350 Methods of testing portland and blended cements
 2758 Aggregates and rock for engineering purposes
 2758.1 Part 1: Concrete aggregates
 2783 Use of reinforced concrete for small swimming pools
 2870 Residential slabs and footings—Construction
 3000 Electrical installation (known as the Australia/New Zealand Wiring Rules)
 3582 Supplementary cementitious materials for use with portland cement
 3582.2 Part 2: Slag—Ground granulated iron blast-furnace
 3600 Concrete structures
 3600.1 Supplement 1—Concrete structures—Commentary
 3610 Formwork for concrete
 3735 Concrete structures for retaining liquids
 3799 Liquid membrane-forming curing compounds for concrete
 3972 Portland and blended cements
 4055 Wind loads for housing
 AS/NZS
 1050 Methods for the analysis of iron and steel
 4671 Steel reinforcing materials
 Building Code of Australia
 ISO
 10606 Steel for the reinforcement of concrete—Determination of the strength of joints in welded mesh
 10287 Steel for the reinforcement of concrete—Determination of percentage total elongation at maximum force
 TR 3956 Principles of structural fire-engineering design with special regard to the connection between real fire exposure and the heating conditions of the Standard fire-resistance test (ISO 834)
 ACI
 216R-81 Guide for Determining the Fire Endurance of Concrete Elements
 A1 | 318M-02 Building Code Requirements for Reinforced Concrete
 ASTM
 C42 Test methods for obtaining and testing drilled cores and sawed beams of concrete
 SAI
 HB18.28 Guide 28: General rules for a model third-party certification system for products
 HB64 Guide to concrete construction
 HB67 Concrete practice on building sites
 HB77 Australian Bridge Design Code
 HB77.5 Supp 1: Concrete Supplement
 HB77.8 Supp 1: Railway Supplement (Sections 1–5) Code

BS
8110 Structural use of concrete
8110.2 Part 2: Code of practice for special circumstances

INDEX

- Action (definition)..... 1.6.3.1
 effects (definition)..... 1.6.3.2
 Admixtures, chemical..... 19.1.1
 Aggregates..... 19.1.1
 (see also Lightweight concrete)
 Air entrainment..... 4.8
 Alternative materials or methods..... 1.3
 Analysis
 elastic, for frames with secondary bending..... 7.7
 linear elastic..... 7.6
 methods of..... Section 7
 of continuous beams..... 7.2
 of one-way slabs..... 7.2
 plastic..... 7.9, 7.10
 rigorous..... 7.8
 simplified, for two-way slabs..... 7.3, 7.4
 Anchorage (see also Development length)
 mechanical, strength development by..... 13.1.6
 of flexural reinforcement..... 8.1.8
 of shear reinforcement..... 8.2.12.4, 8.2.12.5
 prestressing
 —construction requirements..... 19.3.3
 —zones..... 12.2
 Beams,
 deep (see Section 12)
 design for durability..... Section 4
 design for fire-resistance..... 5.4
 design for serviceability by
 —crack control..... 8.6
 —deflection limits..... 2.4.2
 design for strength in
 —bending..... 8.1
 —longitudinal shear..... 8.4
 —torsion..... 8.3
 —transverse shear..... 8.2
 detailing of reinforcement
 —for flexure..... 8.1.8
 —for torsion..... 8.3.8
 —transverse shear..... 8.2.12
 minimum reinforcement
 —bending tensile..... 8.1.4.1
 —shear..... 8.2.8
 —torsional..... 8.3.7
 Bearing surfaces..... 12.3
 Bending
 columns in
 —bi-axial and compression..... 10.4.1, 10.6.5
 of reinforcement..... 19.2.3
 strength of beams in..... 8.1
 strength of slabs in..... 9.1
 Bending moment
 design (definition M^*)..... 1.7
 Bending strength
 of columns..... 10.6
 of beams..... 8.1
 of slabs..... 9.1
 Bracing of walls..... 11.3
 Braced frame..... A3, A11.3,
 Breaking load
 of tendons (wire, strand and bars)..... Table 6.3.1
 Buckling (of columns)
 critical-load analysis..... 10.4.3
 effects (see Slenderness)
 load..... 10.4.4
 Bundled bars
 development length..... 13.1.4
 in beams..... 8.1.8.8
 in columns..... 10.7.2
 splices for..... 13.2.6
 Capacity reduction factor (see Strength,
 reduction factor)
 Cathodic protection..... 18.3.2
 Cement
 blended..... Appendix C
 definition..... 1.6.3.4
 portland..... Appendix C
 Characteristic strength of concrete
 compressive..... 6.1.1.1
 definition..... 1.6.3.5
 flexural tensile..... 6.1.1.2
 of standard strength grades..... 6.1.1.1
 principal tensile..... 6.1.1.3
 Chemical admixtures..... 19.1.1
 Chloride content in concrete
 restriction for corrosion protection..... 4.9
 Cog (see also Hook, standard)
 development length for..... 13.1.2.4
 standard..... 13.1.2.5
 Column strip
 definition..... 7.1.2
 distribution of moments to..... 7.5.5
 distribution of reinforcement and tendons in..... 9.1.2
 Columns
 buckling load..... 10.4.4
 design for strength in combined bending
 and compression..... 10.6
 design procedures..... 10.1
 effective length..... 10.5.3
 reinforcement requirements for..... 10.7
 restraint of longitudinal reinforcement..... 10.7.3
 short, design of,..... 10.3
 slender..... 10.4
 slenderness..... 10.5
 transmission of axial force..... 10.8
 Combinations, load
 for earthquake design..... 3.1.1, A4
 for fire-resistance design..... 3.5
 for serviceability design..... 3.4
 for strength design..... 3.3
 Composite concrete members..... 1.6.3.6
 longitudinal shear..... 8.4
 Compression
 effective flange width of T and L-beams in..... 8.8.2
 end bearing splice in..... 10.7.4.4
 reinforcement
 —in beams, restraint of..... 8.1.8.7
 —in columns..... 10.7
 splices for bars in..... 13.2.5
 strut in non-flexural members..... 12.1.2.2
 Compressive strength
 applicable range of..... 1.1.2
 characteristic (see Characteristic strength)
 mean..... 1.7
 Concrete
 compaction of..... 19.1.3
 control of production by testing..... 19.1.6
 creep..... 6.1.8
 curing and protection of..... 19.1.5
 definition of..... 1.6.3.7
 design properties..... 6.1
 handling and placing..... 19.1.3
 lightweight (definition)..... 1.6.3.31
 manufacture..... 19.1.2
 materials..... 19.1.1
 material and construction requirements..... Section 19
 modulus of elasticity..... 6.1.2
 normal-class..... 19.1.2
 plain..... Section 15
 properties, design..... 6.1
 rejection of..... 19.1.7
 requirements for specifying..... 19.1.2

shrinkage.....	6.1.7	Design	
special-class	19.1.2	aim.....	2.1.1
standard strength grades of.....	6.1.1.1	strip (Definition).....	7.1.2
strength.....	6.1.1	Detailing of reinforcement	
transporting of (<i>see</i> Handling, Placing)		for bending	
Construction		—in beams.....	8.1.8
joints		—in slabs.....	9.1.3
—design of.....	14.1	for shear	
—location of.....	19.4.1	—in columns.....	10.7.3.5
loads.....	3.1.2, 19.6.2.6	—in slabs.....	9.2.6
requirements for.....	Section 19	for shear	
requirements for		—in walls.....	11.5.5
—concrete.....	19.1	in columns.....	10.7
—grout and grouting.....	19.1.8	in walls.....	11.6.3
—prestressing.....	19.3	Development length	
—reinforcing steel.....	19.2	of reinforcement in compression	
Control tests, for stripping and prestressing.....	19.6.2.8	—bundled bars.....	13.1.4
Corbels		—deformed bars.....	13.1.3
additional requirements for.....	12.1.2.6	of reinforcement in tension	
design of.....	12.1	—bars with standard hooks.....	13.1.2.5
Cores, test on.....	B6.4	—bundled bars.....	13.1.4
Cover to reinforcement and tendons		—deformed bars.....	13.1
for corrosion protection.....	4.10.3	—mesh.....	13.1.5
for fire-resistance (structural adequacy) of		of lapped splices.....	13.2.3 to 13.2.6
—beams.....	5.4.2, 5.4.3	of tendons.....	13.3
—columns.....	5.6.3	Development of stress in reinforcement.....	13.1
—slabs.....	5.5.3	Ductility	
—walls.....	5.7.4	definition.....	A3.7
for placement.....	4.10.2	requirements for,	
Crack control		—in earthquake Design category A.....	A7
of beams.....	8.6	—in earthquake Design category B.....	A8
—for tension and flexure.....	8.6.1	—in earthquake Design category C, D and E.....	A9
—for flexure in prestressed beams.....	8.6.2	—in earthquake Design category H.....	A6
—in side faces of.....	8.6.3	Ducts (for prestressing)	
of slabs.....	9.4	friction losses in.....	6.4.2.3
—for flexure.....	9.4.1, 9.4.2	grouting of.....	19.3.4.7
—for shrinkage and temperature.....	9.4.3	requirements for	
in walls.....	11.6.2, 11.6.3	—construction.....	19.3.2
Cracking, control of.....	2.4.4	—materials.....	19.3.2
(<i>see also</i> Crack control)		Durability	
Creep		additional requirements for marine structures.....	18.3
of concrete.....	6.1.8	design for.....	2.6, 4.2
—basic factor.....	6.1.8.1	of concrete, to resist	
—coefficient.....	6.1.8.2	—abrasion.....	4.7
—design.....	6.1.8.2	—corrosion of reinforcement.....	4.9, 4.10
—due to prestress.....	6.4.3.3	—environment exposure.....	4.3 to 4.6
of tendons.....	6.4.2.5, 6.4.3.4	—freeze-thaw cycles.....	4.8
Critical		Earthquake	
opening.....	9.2.1	additional requirements for.....	Appendix A
shear perimeter.....	9.2.1	loads and load combinations.....	3.1.1, A4
Curing		Effective	
accelerated.....	4.4, 4.5, 6.3.4.3	area of support or concentrated load.....	9.2.1
for exposure classifications		depth (definition).....	1.6.3.14
—A1 and A2.....	4.4	design load for deflection.....	8.5.4
—B1, B2 and C.....	4.5	height of a wall.....	11.4.3
of concrete.....	19.1.5	height-to-thickness ratio.....	11.4.2
of test specimens		—maximum for fire-resistance.....	5.7.1
—for site conditions.....	19.6.2.8	length of a column.....	10.5.3
Definitions,		moment of inertia.....	8.5.3.1
administrative.....	1.6.2	span	
technical		—definition (L_{ef}).....	1.7
—for columns.....	10.1.3	—to effective depth (ratio of).....	2.4.2, 9.3.4
—for earthquake design.....	A4	width	
—for fire-resistance.....	5.2	—of a web for shear (b_v).....	1.7, 8.2.6
—for strength of slabs in shear.....	9.2.1	—of compression flange of T- and L-beams.....	8.8.2
—for structural analysis.....	7.1.2	Elastic analysis, methods of.....	7.4, 7.5, 7.6, 7.7
Deformed bars (<i>see</i> Reinforcement)		Elasticity, modulus of,	
Deflection		for concrete.....	6.1.2
by simplified methods.....	8.5.3, 9.3.3	for reinforcement.....	6.2.2
calculation of		Embedded items	
—in beams.....	8.5	general.....	14.2
—in slabs.....	9.3	spacing and cover.....	14.2.4
control of, for serviceability.....	2.4.2	Exposure classifications.....	4.3
limits for.....	2.4.2	cover for.....	4.10.3
to span ratios.....	8.5.4, 9.3.4	requirements for concrete in	
		—A1 and A2.....	4.4

—B1, B2 and C.....	4.5	Grade (<i>see</i> Strength of concrete)	
—U.....	4.6	Grades	
Exposure to fire.....	Section 5	of concrete	
Mesh (<i>see</i> Reinforcement, mesh)		—standard, characteristic strengths of.....	6.1.1.1
		of reinforcement.....	Table 6.2.1
Factors		Grout	
for creep design.....	6.1.8	mixing of.....	19.1.8.2
for moments		properties.....	19.1.8.1
—distributed to column strips.....	7.5.5, Table 7.5.5	requirements for.....	19.1.8
—in spans.....	7.4	Grouting	
—in two-way slabs.....	7.3	of tendon ducts.....	19.3.4.7
—effective length.....	10.5.3	requirements for.....	19.1.8
—end fixity.....	10.5.4	Handling of concrete.....	19.1.3
for deflection (long-term) of		Hardened concrete	
—beams.....	8.5.3, 8.5.4	liable to rejection.....	19.1.7.2, 19.1.7.3
—slabs.....	9.3.3	testing for in situ strength.....	B6
for variability in prototype testing.....	B4.3	Hook/s	
load combination, for		development length of bar with standard.....	13.1.2.5
—strength design.....	3.3	fitment, and anchorage by.....	8.2.12.4
—serviceability design.....	3.4	standard.....	13.1.2.5
strength reduction.....	2.3	lateral restraint of column bars by.....	10.7.3.2
Finishing of unformed surfaces.....	19.1.4	Hot bending of bars.....	19.2.3.1
Fire resistance		Indirect tensile strength tests.....	6.1.1.3
design for.....	Section 5	Insulation, fire-resistance periods for,	
level (definition).....	5.2.1	definition.....	5.2.5
period (definition).....	5.2.2	for beams.....	5.4.1
periods for insulation, integrity and structural		for columns.....	5.6.2
adequacy of		for slabs.....	5.5.1
—beams.....	5.4	for walls.....	5.7.2
—columns.....	5.6	increased by insulating	
—slabs.....	5.5	materials.....	5.4.4, 5.5.4, 5.7.5, 5.10
—walls.....	5.7	Integrity, fire-resistance periods for,	
periods		definitions.....	5.2.6
—by calculation.....	5.9	for beams.....	5.4.1
—from fire tests.....	5.8	for columns.....	5.6.2
—methods for determining.....	5.3.4	for slabs.....	5.5.2
—methods for increasing.....	5.10	for walls.....	5.7.3
—for structural adequacy of ribs.....	5.5.3	Joints	
—for insulation for hollow core slabs.....	5.5.1, 5.7.2	beam-column	
Fire separating function.....	5.2	—in moment resisting frames.....	A12.3.5, A12.3.9
Fitments (<i>see</i> Reinforcement for shear and torsion)		construction	
definition.....	1.6.3.20	—design of.....	14.1.1
Fixings, requirements for.....	14.3	—in pavements and industrial floors,.....	16.2.3
Fixing of		—location of.....	19.4.1
anchorages.....	19.3.3.1	fire-resistance level of.....	5.3.2
ducts.....	19.3.2.3	material and construction requirements for.....	19.4
reinforcement.....	19.2.5	movement.....	14.1.2
tendons.....	19.3.4.4	reinforcement in columns.....	10.7.3.5
Flat slabs		stepped.....	12.1.2.8
analysis of.....	7.4	L-beams	
arrangement of reinforcement in,.....	9.1.3.4	effective width of flange.....	8.8.2
span-to-depth ratio.....	9.3.4.1	shear strength of flange.....	8.8.1
Fly ash.....	Appendix C	Lap splices	
Footings		general.....	13.2
end restraint provided by.....	10.5.6	for bundled bars.....	13.2.5
residential.....	16.3	for deformed bars	
Force/s (<i>see</i> also Action, Loads)		—in compression.....	13.2.4
axial		—in tension.....	13.2.2
—and bending.....	8.1.2.1	for mesh.....	13.2.3
—small in short columns.....	10.3.2	in column ties and helices.....	10.7.3.4
—transmission of through floors.....	10.8	in longitudinal column reinforcement.....	10.7.4
horizontal on walls.....	11.2.3 to 11.2.6	Lateral drift, general.....	2.4.3
shear.....	8.2.1	Lateral restraint of reinforcement	
tensile		compression, in beams.....	8.1.8.7
—in non-flexural members.....	12.1.3.3	longitudinal, in columns.....	10.7.3
—in prestressed anchorage zone.....	12.2.4, 12.2.5	in earthquake resistant frames.....	A11, A12
maximum jacking.....	19.3.4.6	Lateral support for braced walls.....	11.3
Formwork.....	19.6	Lightning protection by reinforcement.....	19.2.6
design and construction of.....	19.6.1	Lightweight concrete.....	1.6.3.31
stripping of.....	19.6.2	Liquid retaining structures.....	Section 17
removal of supports from.....	19.6.2	Load combinations, for	
Friction losses.....	6.4.2.3	earthquake design.....	A4
Foundations		fire-resistance design.....	3.5
movements.....	3.1.3	prestress at transfer.....	3.3.1
for pavements and floors.....	16.2.1		

serviceability design.....	3.4	Prestress	
stability design.....	3.2	dispersion angle of.....	8.1.2.3
strength design.....	3.3	loss of in tendons.....	6.4
Load testing		secondary moments and shears from.....	7.6.7
design by.....	2.5	Prestressed	
of a completed structure.....	B3	beams	
of a prototype.....	B4	—bending strength at transfer.....	8.1.4.2
Loads		—design strength in bending.....	8.1.3, 8.1.5
additional for marine structures.....	18.2	—shear strength.....	8.2.6, 8.2.7.2
and other actions.....	3.1	—slender.....	8.9.4
allocation to beams and walls.....	7.3.4	columns.....	Section 10, A12.3.8
concentrated		—definition.....	10.1.3
—slab shear from.....	9.2	—exposure classification for.....	Table 4.3
—slab width supporting.....	9.6	liquid retaining structures.....	Section 17
construction.....	3.1.2	slabs	
—of beams.....	8.5.4	—bending strength of.....	9.1.1
effective design, for deflection		—crack control in flexure.....	9.4.2
—of slabs.....	9.3.4.1	—shear strength in.....	9.2
vertical arrangement of, in buildings		Prestress	
—for idealized frame analysis.....	7.5.3	anchorage	
—for linear elastic analysis.....	7.6.4	—anchorage zone for.....	12.2
Loss of prestress in tendons.....	6.4	—friction in.....	6.4.2.3
immediate.....	6.4.2	—loss of prestress at.....	6.4.2.4
time-dependent.....	6.4.3	—material and construction requirements.....	19.3.1, 19.3.2
Manufacture of concrete.....	19.1.2	—stress development by.....	13.3.3
Marine structures.....	Section 18	bar (see Tendons)	
Material and construction requirements.....	Section 19	ducts (see Ducts)	
for concrete and grout.....	19.1	strand (see Tendons)	
for joints and embedded items.....	19.4	tendons (see Tendons)	
for prestressing ducts, anchorages and tendons.....	19.3	wire (see Tendons)	
for reinforcing steel.....	19.2	Production control testing of concrete	
Materials		general requirements for.....	19.1.2, 19.1.6
design properties of.....	Section 6	Project control testing of concrete	
for concrete and grout.....	19.1.1	general requirements.....	19.1.2, 19.1.6.2
for ducts, anchorages and tendons.....	19.3.1	Protection	
for reinforcement.....	19.2.1.1	of concrete	
limitations on for embedded items.....	14.2.2	—freshly placed.....	19.1.5.2
use of alternative.....	1.3	—hardened.....	19.1.5.1, 19.1.5.2
Mechanical splices.....	13.2.1	of reinforcement and tendons	
Moment		—against corrosion.....	4.10, 19.2.1.2
design		—against fire (see Fire-resistance)	
—negative.....	7.2.2	Properties of materials	
—positive.....	7.2.3	for concrete.....	6.1
magnifier for slender columns.....	10.4	for grout.....	6.1
redistribution.....	7.6.8, 7.6.9	reinforcement.....	6.2
resisting width supporting concentrated loads.....	9.6	tendons.....	6.3
torsional.....	7.3.3, 7.5.6	Quality control of concrete	
total static, in slab spans.....	7.4.2	(see Production control, Project control)	
transfer, for shear in flat-slabs.....	9.2	Ratio/s	
Moment of inertia (see Second moment of area)		deflection to span.....	Table 2.4.2
Moment-resisting frames (for earthquake design)		height to thickness (of walls).....	5.7.4, 11.4.2
definition.....	A3.12	reinforcement	
requirements for.....	A12	—for columns.....	10.7.1
Moments		—for crack control.....	9.4.3
bending (see Bending moment, Moment)		—for minimum flexural strength.....	8.1.4.1, 9.1.1
Modulus of elasticity		—for shrinkage and temperature effects.....	9.4.3
of concrete.....	6.1.2	—minimum in walls.....	11.6.1
of reinforcement.....	6.2.2	slenderness (see Slenderness)	
of tendons.....	6.3.2	span to depth	
Nibs, continuous.....	12.1.2.7	—for beams.....	8.5.4
Notation.....	1.7	—for slabs.....	9.3.4
Overturning, sliding and uplift.....	2.2	Ready-mixed concrete (see Manufacture of concrete)	
Pipes (see also Embedded items)		Rectangular stress block assumption.....	8.1.2.2, 10.6.2
containing liquid, gas, or vapour.....	14.2.3	Reduction factor for strength.....	2.3, Table 2.3
Placing of concrete.....	19.1.3	Reinforcement	
Plain concrete members		anchorage of	
design for strength and serviceability.....	Section 15	—positive moment.....	8.1.8.4
exposure classifications for.....	Table 4.3	—bars for shear.....	8.2.12.4
strength of		—mesh for shear.....	8.2.12.5
—in axial compression.....	15.5	arrangement of	
—in bending.....	15.3	—general procedure.....	8.1.8.2, 9.1.3.1, 11.6.1, 12.2.6
—in combined bending and compression.....	15.6	—deemed to comply.....	8.1.8.5, 9.1.3.2 to 9.1.3.4
—in shear.....	15.4	bending of.....	19.2.3
		compression	

—for deflection control	8.5.3.3
—lateral restraint of	8.1.8.6, 10.7.3, 11.6.4
—limitations on	8.1.3
construction requirements for	19.2
definition of	1.6.3.4.2
detailing of	
—in anchorage zones	12.2.6
—in beams	8.1.8, 8.2.12, 8.3.8
—in columns	10.7.3, 10.7.4
—in slabs	9.1.3, 9.2.6
development length of (see Development of stress in)	
development of stress in	13.1
distribution in flat slabs	9.1.2
ductility	1.1.1, 5.9, 6.2.1, 7.6.8.1, 7.6.8.2, 7.6.8.3, 7.9.1, A12.1
mesh	19.2.1.1
fabrication of	19.2.2
for crack control	
—at openings and discontinuities	8.6.4, 9.4.5
—in beam tension and flexure	8.6.1
—in beam side faces	8.6.3
—in prestressed beam flexure	8.6.2
—in walls	11.6.2
—slab flexure	9.4.1
—slab shrinkage and temperature	9.4.3
in beams	
—flexural	8.1.8
—shear	8.2.5, 8.2.8 to 8.2.12, 8.4.5
—suspension	8.2.11
—torsional	8.3.4, 8.3.6 to 8.3.8
in columns	10.7
in slabs,	
—flexural	9.1.2, 9.1.3, 9.1.4
—for crack control	9.4
—for shrinkage and temperature	9.4.3
materials	19.2.1
properties of	6.2
ratios (see Ratios)	
shear	
—in beams	8.2.5, 8.2.8, 8.2.10, 8.2.12, 8.4.5
—in columns	10.7.3
—in slabs	9.2.5, 9.2.6
—in walls	11.5.5
spacing of	
—in beams	8.1.7, 8.2.12.2, 8.3.8, 8.6
—in columns	10.7.3.3
—in non-flexural members	12.1.1.3
—in slabs	9.1.4, 9.4
—in walls	11.6.3
splicing of	13.2
stress at ultimate strength	8.1.5
torsional	
—in beams	8.3.4 to 8.3.8
—in slabs	9.2.5, 9.2.6
Rejection of concrete	19.1.7
Relaxation of tendons	6.3.4
Ribbed slabs	
definition	5.2.8
fire resistance periods for	5.5.1 to 5.5.3
two-way (waffle) analysis of	7.4, 7.5, 7.6
Ribs	
fire resistance requirements for	5.5.3, Table 5.5.3(B)
Sampling of concrete	
for site control tests	19.6.2.8
Scope	1.1.1, 5.1, A1
Second moment of area	
effective	8.5.3.1
of cracked section (I_{cr})	1.7, 8.5.3.1
Serviceability	
deflection limits	2.4.1
design for	
—general	2.4
—in beams	8.5 to 8.8
—in slabs	9.3 to 9.5
load combinations for	3.4
Shear	
critical perimeter	
—definition	9.2.1.1
critical perimeter	
—location	Figure 9.2.1(A)
forces in beam-and-slab construction	7.4.6
longitudinal	
—in beams	8.4
—in slabs	9.7
maximum near a support	8.2.4
minimum transverse	7.6.11
reinforcement (see Reinforcement, shear)	
simplified analysis for	7.2.4
strength	
—of beams	8.2
—of column joints	10.7.3.5
—of plain concrete	15.4
—of slabs	9.2
—of walls	11.5
walls	11.5, A3.15, A11.2
Shoring (see Stripping)	
Shrinkage and temperature	
actions	3.1.3
calculation of	6.1.7
crack control	
—in pavements and industrial floors	16.2.3
crack control	
—in slabs	9.4.3
—in walls	11.6.2
limitation on sulphate content for	19.1.1
loss of prestress due to	6.4.3.2
Slabs	
analysis methods	
—general	Section 7
—for one-way	7.2
—for two-way	7.3, 7.4, 7.5
—plastic	7.9
design for durability	Section 4
design for fire-resistance	5.5
design for serviceability by	
—crack control	9.4
—deflection limits	2.4.2
design for strength in	
—bending	9.1
—longitudinal shear	9.7
—shear	9.2
definitions for	1.6.3, 5.2, 7.1.2, 9.2.1
deflection of	9.3
detailing of reinforcement	
—for flexure	9.1.3, 9.1.4
—for shear	9.2.6
flat (see Flat slabs)	
minimum reinforcement for continuous two-way ...	9.1.1
strips in flat, (design, column, middle)	
—definitions	7.1.2
—design moment for	7.4.3, 7.4.4
—distribution of moments between	7.5.5
vibration of	9.5
Slenderness	
limits for beams	8.9
of columns	10.4, 10.5
of prestressed beams	8.9.4
of walls	5.7.4, 11.4.2
(see also Ratio, height-to-thickness)	
Spacing of reinforcement and tendons	
(see Reinforcement, spacing)	
Span-to-depth ratio	
deemed to comply	
—for reinforced beams	8.5.4
—for reinforced slabs	9.3.4
Specification of concrete	
in contract documents	1.4.2
normal-class	19.1.2
special-class	19.1.2
Splices in reinforcement (see Reinforcement)	

Stability	
design for	2.2
load combinations for	3.2
Standard strength grades	6.1.1.1
Steam cured concrete	19.1.5.1
(see also Curing, accelerated)	
Strength	
of concrete	
—average	19.1.6.2
—characteristic	6.1.1
—early-age	19.1.6.3, 19.6.2.8
—grade	1.6.3, 6.1.1, 19.1.2, 19.1.6.2
of tendons	6.3.1
reduction factor	2.3, Table 2.3
ultimate (see Ultimate strength)	
yield, of reinforcement	6.2.1
Stripping of formwork	19.6.2
Strut and tie action	
design based on	12.1.2
Surface finishing	19.1.4
T-beams	
effective width of flange	8.8.2
effective moment of inertia	8.5.3.1
Temperature effects (see Shrinkage)	
Tendons	
construction requirements for	19.3.1.3, 19.3.4, 19.3.5
coupling of	13.4
cover to	
—for corrosion protection	4.10.3
—for fire-resistance	5.4.2, 5.4.3, 5.5.3, 5.6.3, 5.7.4
definition of	1.6.3.49
grouting of	19.3.4.7
loss of prestress in	6.4
not yet bonded	8.1.6
properties of	6.3
strength of	6.3.1
stress at ultimate strength	8.1.5
tolerance on position	19.5.3
Tension tie	12.1.2.4
Tensioning of tendons	19.3.4.5
Testing	
for design properties	
—of concrete	6.1
—of reinforcement	6.2
—of tendons	6.3
of concrete	
—for control of stripping or stressing	19.6.2.8
—hardened, in place	B6
of members and structures	Appendix B
proof	B3
prototype	2.5, B4
Thickness	
hypothetical	1.7, Figures 6.1.7.2, 6.1.8.2(A)
minimum, of components in interface shear	8.4.6
minimum effective, for fire-resistance	
—of additional insulating material	5.10.1.3
—of slabs	5.5.1
—of walls	5.7.2
Tolerances	
for fabrication of reinforcement	19.2.2
for position and size of members	19.5.2
on position of reinforcement and tendons	19.5.3
Torsion	
and shear	
—in beams	8.3
—in flat slabs	9.2
redistribution	8.3.2
reinforcement, (see Reinforcement, torsional)	
strength	
—limited by web crushing	8.3.3
—of a beam	8.3.5
strip (definition)	9.2.1.4
Transmission length	13.3.2
(see also, Development length, of tendons)	
Ultimate strength	
of beams in bending	
—basic principles	8.1.2
—minimum	8.1.4
of beams in shear	8.2.6, 8.2.7, 8.2.9
of beams in torsion	8.3.5
of columns	
—centrically loaded	10.6.3
—under combined bending and compression	10.6
of slabs in bending	
—basic principles	8.1.2
—general	9.1.1
of slabs in shear	9.2.3, 9.2.4
of walls	
—for axial compression	11.4.4
—for in-plane bending	11.5.1
—for in-plane shear	11.5.3, 11.5.4
Uplift (see Stability, design for)	
Walls	
bracing of	11.3
braced, simplified design for	11.4
design of	Section 11
design procedures	11.2
fire-resistance periods for	5.7
hollow-core (definition)	5.2.4
minimum effective thickness	5.7.2
reinforcement requirements for	11.6
Welding	
of reinforcement	19.2.2
of splices	13.2.1
of tendons	19.3.4.1
Water	
exposure classification for members in	Table 4.3
Water retaining structures (see Liquid retaining structures)	
Yield-line analysis method	7.9.3
Yield strength	
of reinforcement	6.2.1
of tendons	6.3.1

AMENDMENT CONTROL SHEET

AS 3600—2001

Amendment No. 1 (2002)

CORRECTION

SUMMARY: This Amendment applies to Clauses 1.1.2, 1.7, 7.2.1(e), 7.4.1(h), 8.1.4.1, 8.1.8, 8.1.8.1, 8.2.12.4, 8.5.3.1, 8.6.1, 9.3.4.1, 9.4.1, 10.6.2(b), 10.7.4.3, Table 6.1.7.2, Figures 4.3, 6.1.7.2 (A), and 6.1.7.2 (B), Appendices A, B and C.

Published on 24 May 2002.

STANDARDS AUSTRALIA

**Amendment No. 2
to
AS 3600—2001
Concrete structures**

REVISED TEXT

The 2001 edition of AS 3600—2001 is amended as follows; the amendments should be inserted in the appropriate places.

SUMMARY: This Amendment applies to the Clauses 7.1.1, 7.2.1, 7.2.2, 7.2.3, 7.3.1, 7.3.2, 7.3.4, 7.4.1, 7.5.1, 7.6.2, 7.6.8.1, 7.6.8.3, 8.1.8.4, 8.6.1, 9.2.4, 9.4.1, 19.2.1.1 and Tables 2.3 and 7.3.2.

Published on 28 October 2004.

AMDT
No. 2
OCT
2004

Page 23 Table 2.3

Add the following Note under Table 2.3:

NOTE: Refer to Clauses 7.2.1, 7.3.1 and 7.6.8.3 when using Class L reinforcement.

AMDT
No. 2
OCT
2004

Page 59 Clause 7.1.1(e)

Delete 'For reinforced or prestressed structures' and replace with the following:

'(e) For reinforced or prestressed concrete beams, slabs or structures—'

AMDT
No. 2
OCT
2004

Page 62 Clause 7.2.1

- 1 Delete 'and' from Item (e).
- 2 Delete '.' from Item (f) and replace with '; and'.
- 3 Insert the following new Item to the Clause:
 - '(g) where Class L reinforcement is used as the main reinforcement the design capacity of the beam or slab, calculated in accordance with Sections 8 or 9, is reduced by not less than 20%.'

AMDT
No. 2
OCT
2004

Page 62 Clause 7.2.2

Delete Item (a)(i) and replace with the following:

'(i) Two spans only $F_d L_n^2 / 9$ Class N; or
 $F_d L_n^2 / 8$ Class L.'

AMDT
No. 2
OCT
2004

Page 62 Clause 7.2.3

Delete Item (b) and replace with the following:

'(b) In interior spans $F_d L_n^2 / 16$ Class N; or
 $F_d L_n^2 / 14$ Class L.'

Page 63 Clause 7.3.1

- 1 *Insert* ‘and the corners are prevented from lifting’ *after* ‘four sides’ in the first paragraph.
- 2 *Delete* ‘and’ from Item (b).
- 3 *Delete* ‘.’ from Item (c) and *replace* with ‘;’.
- 4 *Insert* the following new Items to the Clause:
 - (d) where Class L reinforcement is used as the main reinforcement, the design capacity of the slab, calculated in accordance with Section 9, is reduced by not less than 20%; and
 - (e) slabs incorporating Class L mesh are continuously supported on walls.’

Page 63 Clause 7.3.2

Delete the text of Clause 7.3.2 and *replace* with the following:

‘The design bending moments in a slab shall be determined as follows:

- (a) The positive design bending moments at mid-span, M_x^* and M_y^* on strips of unit width spanning L_x and L_y , respectively, shall be calculated from the following equations:

$$M_x^* = \beta_x F_d L_x^2$$

$$M_y^* = \beta_y F_d L_x^2$$

where F_d is the uniformly distributed design load per unit area factored for strength, and β_x and β_y are given in—

- (i) Table 7.3.2(A) for slabs with Class N reinforcement (bars or mesh) as the main flexural reinforcement; and
- (ii) Table 7.3.2(B) for slabs with Class N reinforcement (bars or mesh) or Class L mesh as the main flexural reinforcement and no moment redistribution can be accommodated at either the serviceability or strength limit states.

The moments, so calculated, shall apply over a central region of the slab equal to three-quarters of L_x and L_y respectively. Outside of this region, the requirement for strength shall be deemed to be complied with by the minimum strength requirement of Clause 9.1.1.

- (b) The negative design bending moments at a continuous edge shall be taken as—
 - (i) 1.33 times the mid-span values in the direction considered when they are taken from Table 7.3.2(A); or
 - (ii) α_x or α_y times the mid-span values in the direction considered when they are taken from Table 7.3.2(B), where the value of α_x or α_y is also taken from Table 7.3.2(B) for the appropriate case.

If the negative moment on one side of a common support is different from that on the other side—

- (A) the unbalanced moment may be redistributed (in proportion to the stiffness of span L_x in the adjacent panels) if Class N reinforcement (bars or mesh) are the main flexural reinforcement; or
- (B) the slab shall be reinforced on both sides of the support for the larger support moment.

- (c) The negative design bending moment at a discontinuous edge, where there is a likelihood of restraint, may be taken as—
- (i) 0.5 times the mid-span values in the direction considered when they are taken from Table 7.3.2(A); or
 - (ii) 0.8 times the mid-span values in the direction considered when they are taken from Table 7.3.2(B).

AMDT
No. 2
OCT
2004

Page 63 Clause 7.3.4

Add the following after ‘...in Figure 7.3.4’

‘, provided—

- (a) the reactions apply directly when all edges are continuous;
- (b) when one edge is discontinuous, the reactions on all continuous edges are increased by 10% and the reaction on the discontinuous edge can be reduced by 20%; and
- (c) when adjacent edges are discontinuous, the reactions are adjusted for elastic shear considering each span separately’

AMDT
No. 2
OCT
2004

Page 64 Table 7.3.2

Replace table designation ‘**TABLE 7.3.2**’ with ‘**TABLE 7.3.2(A)**’.

AMDT
No. 2
OCT
2004

Page 64 Table 7.3.2

Insert new Table 7.3.2(B) as follows:

TABLE 7.3.2(B)
ELASTIC BENDING MOMENT COEFFICIENTS FOR RECTANGULAR SLABS
SUPPORTED ON FOUR SIDES

Edge condition	Short span coefficients (β_x and α_y)									Long span coefficients (β_y and α_x) for all values of L_y/L_x
	Values of L_y/L_x									
	1.0	1.1	1.2	1.3	1.4	1.5	1.75	2.0	>2.0	
1 Four edges continuous	0.021	0.025	0.029	0.032	0.034	0.036	0.039	0.041	0.042	0.020
	2.31	2.22	2.14	2.04	2.06	2.03	2.00	2.00	2.00	2.69
2 One short edge discontinuous	0.027	0.030	0.033	0.035	0.037	0.039	0.041	0.042	0.042	0.024
	2.20	2.14	2.10	2.06	2.04	2.02	2.00	2.00	2.00	2.29
3 One long edge discontinuous	0.024	0.028	0.034	0.038	0.043	0.047	0.056	0.061	0.070	0.028
	2.22	2.17	2.09	2.03	1.97	1.93	1.86	1.81	1.80	2.46
4 Two short edges discontinuous	0.032	0.035	0.037	0.038	0.039	0.040	0.042	0.042	0.042	0.024
	2.09	2.05	2.03	2.01	2.00	2.00	2.00	2.00	2.00	—
5 Two long edges discontinuous	0.024	0.028	0.035	0.042	0.049	0.056	0.071	0.085	0.125	0.039
	—	—	—	—	—	—	—	—	—	2.31
6 Two adjacent edges discontinuous	0.031	0.036	0.041	0.046	0.050	0.053	0.060	0.064	0.070	0.034
	2.13	2.07	2.01	1.87	1.92	1.89	1.83	1.80	1.80	2.13
7 Three edges discontinuous (one long edge continuous)	0.039	0.044	0.048	0.052	0.055	0.058	0.063	0.066	0.070	0.035
	2.04	1.97	1.93	1.89	1.86	1.84	1.80	1.80	1.80	—
8 Three edges discontinuous (one short edge continuous)	0.033	0.039	0.047	0.054	0.061	0.067	0.082	0.093	0.125	0.046
	—	—	—	—	—	—	—	—	—	2.12
9 Four edges discontinuous	0.044	0.052	0.059	0.066	0.073	0.079	0.091	0.100	0.125	0.049
	—	—	—	—	—	—	—	—	—	—

Page 64 Clause 7.4.1

Insert the following new Item (i) to the Clause:

- (i) Class L reinforcement is not used as the main flexural reinforcement.

Page 67 Clause 7.5.1

Replace the first sentence with the following:

Provided that Class L reinforcement is not used as the main flexural reinforcement, this Clause applies to the analysis of reinforced and prestressed framed structures incorporating two-way slab systems having multiple spans including—

Page 69 Clause 7.6.2

Third paragraph, *delete* ‘, except that the following simplifications may be used:’ and *replace* with ‘. Provided Class L reinforcement is not used, the following simplifications may be applied:’

Page 71 Clause 7.6.8.1

Delete the last paragraph.

Page 71 Clause 7.6.8.3

Delete the text of Clause 7.6.8.3 and *replace* with the following:

Where linear elastic analysis is used and it is intended to use Class L reinforcement, then the following applies:

- (a) *Beams or one-way slabs and supports* Reinforcement shall be provided to carry the elastic distributions of stresses at all locations.
- (b) *Two-way slab systems* The analysis shall model the slabs as a system of plates and supports. Reinforcement shall be provided to carry the elastic distributions of stresses (including calculated torsions) at all locations within the slab system.

Where Class L reinforcing steel is used as the main reinforcement, the effects that relative foundation movements, variations in loading arrangements and accidental loadings can have on the strength of beams and slabs shall be assessed and the design capacity of the member, calculated in accordance with Section 8 or 9, reduced by not less than 20%.

Page 77 Clause 8.1.8.4(a)

Delete reference to 'Clause 13.1.2.3' and *replace* with 'Clause 13.2.2'.

Page 89 Clause 8.6.1

Delete the text of Clause 8.6.1 and *replace* with the following:

For the purpose of this Clause the resultant action is considered to be *primarily tension* when the whole of the section is in tension, or *primarily flexure* when the tensile stress distribution within the section prior to cracking is triangular with some part of the section in compression.

Cracking in reinforced beams subjected to tension, flexure with tension, or flexure, shall be deemed to be controlled if the appropriate requirements in Items (a) and (b), and either Item (c) for beams primarily in tension or Item (d) for beams primarily in flexure, are satisfied. For regions of beams fully enclosed within a building except for a brief period of weather exposure during construction, and where it is assessed that crack control is not required, only Item (b) need be satisfied.

- (a) The minimum area of reinforcement in a tensile zone of a beam shall comply with Clause 8.1.4.1.
- (b) The distance from the side or soffit of a beam to the centre of the nearest longitudinal bar shall not exceed 100 mm. Bars with a diameter less than half the diameter of the largest bar in the section shall be ignored. The centre-to-centre spacing of bars near a tension face of the beam shall not exceed 300 mm. For T-beams and L-beams, the reinforcement required in the flange shall be distributed across the effective width.
- (c) For beams primarily subject to tension, the calculated steel stress (f_{scr}) shall not exceed the maximum steel stress given in Table 8.6.1(A) for the largest nominal diameter (d_b) of the bars in the section, and under direct loading the calculated steel stress ($f_{scr.1}$) shall not exceed $0.8f_{sy}$.
- (d) For beams primarily subject to flexure, the calculated steel stress (f_{scr}) shall not exceed the larger of the maximum steel stresses given in—

- (i) Table 8.6.1(A) for the largest nominal diameter (d_b), of the bars in the tensile zone; and
- (ii) Table 8.6.1(B) for the largest centre-to-centre spacing of adjacent parallel bars in the tensile zone.

Under direct loading the calculated steel stress ($f_{scr.1}$) shall not exceed $0.8f_{sy}$. Bars with a diameter less than half the diameter of the largest bar in the section shall be ignored when determining spacing.

NOTE: Design bending moments M_s^* and $M_{s.1}^*$ at the serviceability limit state will normally be estimated using elastic analysis. Significant errors may result if they are determined from the design bending moments M^* at the strength limit state when the amount of moment redistribution is unknown; for example, if plastic methods of analysis are used for strength design.

AMDT
No. 2
OCT
2004

Page 99 Clause 9.2.4(b)

Delete the equation in Item (b) and *replace* with the following:

$$V_{u.min.} = 1.2V_{uo} / [1.0 + (uM_v^* / 2V^* a^2)]$$

AMDT
No. 2
OCT
2004

Page 103 Clause 9.4.1

Delete the text of Clause 9.4.1 and *replace* with the following:

Cracking in reinforced slabs subject to flexure shall be deemed to be controlled if the appropriate requirements in Items (a), (b), (c) and (d) are satisfied. For areas of slabs fully enclosed within a building except for a brief period of weather exposure during construction and, where it is assessed that crack control is not required, only Item (a) and Item (b) need be satisfied.

- (a) The minimum area of reinforcement in a tensile zone of a slab shall comply with Clause 9.1.1.
- (b) The centre-to-centre spacing of bars in each direction shall not exceed the lesser of $2.0D_s$ or 300 mm. Bars with a diameter less than half the diameter of the largest bar in the cross-section shall be ignored.
- (c) The calculated steel stress (f_{scr}) shall not exceed the larger of the maximum steel stresses given in—
 - (i) Table 9.4.1(A) for the largest nominal diameter (d_b) of the bars in the tensile zone; and
 - (ii) Table 9.4.1(B) for the largest centre-to-centre spacing of adjacent parallel bars in the tensile zone, and, when determining spacing, bars with a diameter less than half the diameter of the largest bar in the section shall be ignored.
- (d) The calculated steel stress $f_{scr.1}$ shall not exceed $0.8f_{sy}$.

NOTE: Design bending moments M_s^* and $M_{s.1}^*$ at the serviceability limit state will normally be estimated using elastic analysis. Significant errors may result if they are determined from the design bending moments M^* at the strength limit state when the amount of moment redistribution is unknown; for example, if plastic methods of analysis are used for strength design.

AMDT
No. 2
OCT
2004

Page 142 Clause 19.2.1.1

Insert the following after the last paragraph:

‘Class L reinforcement shall not be substituted for Class N reinforcement unless the structure is redesigned.’

Standards Australia

Standards Australia is an independent company, limited by guarantee, which prepares and publishes most of the voluntary technical and commercial standards used in Australia. These standards are developed through an open process of consultation and consensus, in which all interested parties are invited to participate. Through a Memorandum of Understanding with the Commonwealth government, Standards Australia is recognized as Australia's peak national standards body. For further information on Standards Australia visit us at

www.standards.org.au

Australian Standards

Australian Standards are prepared by committees of experts from industry, governments, consumers and other relevant sectors. The requirements or recommendations contained in published Standards are a consensus of the views of representative interests and also take account of comments received from other sources. They reflect the latest scientific and industry experience. Australian Standards are kept under continuous review after publication and are updated regularly to take account of changing technology.

International Involvement

Standards Australia is responsible for ensuring that the Australian viewpoint is considered in the formulation of international Standards and that the latest international experience is incorporated in national Standards. This role is vital in assisting local industry to compete in international markets. Standards Australia represents Australia at both ISO (The International Organization for Standardization) and the International Electrotechnical Commission (IEC).

Electronic Standards

All Australian Standards are available in electronic editions, either downloaded individually from our web site, or via On-Line and DVD subscription services. For more information phone 1300 65 46 46 or visit Standards Web Shop at

www.standards.com.au



GPO Box 5420 Sydney NSW 2001

Administration Phone (02) 8206 6000 Fax (02) 8206 6001 Email mail@standards.com.au

Customer Service Phone 1300 65 46 46 Fax 1300 65 49 49 Email sales@standards.com.au

Internet www.standards.org.au

ISBN 0 7337 3931 8

Printed in Australia

