

## **Central Coast Local Provisions Schedule**

## **Accessibility Disclaimer**

Tasmanian Planning Commission aims to make planning scheme information accessible to all users.  
Alternative text or alt-text is a short textual description of an image that is not visible in a document.

It is included to assist users of Planning Schemes, particularly vision impaired users, who use screen readers to understand the content of images.

Where information is in a format that is not accessible, or for any other accessibility difficulties, please contact [tpc@planning.tas.gov.au](mailto:tpc@planning.tas.gov.au) for further assistance.

## Local Provisions Schedule amendments

No.	Effective date	Amendment no	Amendment information	Text/Map
5	9 July 2025	section 80O alteration	Miscellaneous changes to ensure consistent use of formatting, grammar, expression, numerical referencing, and punctuation.	Text
4	31 March 2025	PSA2024001	Rezone 1685 Castra Road, Sprent from Agriculture to Rural and apply the priority vegetation area overlay.	Map
3	22 January 2025	Ministerial direction (Housing Land Supply Order)	Rezone 18A Lester Road, Penguin from Rural Living A and Utilities Zone to General Residential Zone.	Map
2	24 March 2023	LPS2022001	Rezone folio of the Register 141816/1 South Road, West Ulverstone from Low Density Residential to CCO-P1.0 Particular Purpose Zone - South Road, West Ulverstone and insert the new Particular Purpose Zone	Text and map
1	27 October 2021	Not applicable	Commencement of LPS under section 35M of the <i>Land Use Planning and Approvals Act 1993</i>	Text

## TABLE OF CONTENTS

<b>CCO-Local Provisions Schedule Title</b>	<b>5</b>
<b>CCO-Effective Date</b>	<b>5</b>
<b>CCO-Local Area Objectives</b>	<b>5</b>
<b>CCO-Particular Purpose Zones</b>	<b>5</b>
CCO-P1.0 Particular Purpose Zone - South Road, West Ulverstone	5
<b>CCO-Specific Area Plans</b>	<b>13</b>
CCO-S1.0 Forth Specific Area Plan	13
CCO-S2.0 Leith Specific Area Plan	19
CCO-S3.0 Penguin Specific Area Plan	21
CCO-S4.0 Revell Lane Specific Area Plan	29
CCO-S5.0 Turners Beach Specific Area Plan	34
<b>CCO-Site-Specific Qualifications</b>	<b>43</b>
<b>CCO-Code Lists</b>	<b>43</b>
CCO-C3.0 Road and Railway Assets Code	43
CCO-C6.0 Local Historic Heritage Code	43
CCO-C8.0 Scenic Protection Code	45
CCO-C11.0 Coastal Inundation Hazard Code	46
<b>CCO-Applied, Adopted or Incorporated Documents</b>	<b>47</b>

## **CCO-Local Provisions Schedule Title**

CCO-This Local Provisions Schedule is called the Central Coast Local Provisions Schedule and comprises all 1.1 the land within the municipal area.

## **CCO-Effective Date**

CCO-The effective date for this Local Provisions Schedule is 27 October 2021  
1.2

## **CCO-Local Area Objectives**

This clause is not used in this Local Provisions Schedule.

## **CCO-Particular Purpose Zones**

### **CCO-P1.0 Particular Purpose Zone - South Road, West Ulverstone**

#### **CCO-P1.1 Zone Purpose**

The purpose of the South Road Particular Purpose Zone is:

CCO- To provide for the use and development of a service station and associated food services tenancies.  
P1.1.1

CCO- To provide appropriate facilities that cater specifically to freight and transport service providers and staff.  
P1.1.2

#### **CCO-P1.2 Local Area Objectives**

This clause is not used in this particular purpose zone.

#### **CCO-P1.3 Definition of Terms**

This clause is not used in this particular purpose zone.

**CCO-P1.4 Use Table**

Use Class	Qualification
<b>No Permit Required</b>	
Natural and Cultural Values Management	If for minor utilities.
Utilities	
<b>Permitted</b>	
No uses	
<b>Discretionary</b>	
Food Services	Must be associated with a service station.
Vehicle Fuel Sales and Service	If for a service station.
Utilities	If not listed as No Permit Required.
<b>Prohibited</b>	
All other uses	

**CCO-P1.5 Use Standards**

CCO-P1.5.1 All uses

<b>Objective:</b>	That uses do not cause unreasonable loss of amenity to residential zones.	
<b>Acceptable Solutions</b>		<b>Performance Criteria</b>
<p><b>A1</b></p> <p>Hours of operation of a use, excluding Natural and Cultural Values Management, or Utilities, on a site within 50m of a General Residential Zone, Inner Residential Zone or Low Density Residential Zone, must be within the hours of:</p> <p>(a) 7.00am to 9.00pm Monday to Saturday; and</p> <p>(b) 8.00am to 9.00pm Sunday and public holidays.</p>	<p><b>P1</b></p> <p>Hours of operation of a use, excluding Natural and Cultural Values Management, or Utilities, on a site within 50m of a General Residential Zone, Inner Residential Zone or Low Density Residential Zone, must not cause an unreasonable loss of amenity to the residential zones, having regard to:</p> <p>(a) the timing, duration or extent of vehicle movements; and</p> <p>(b) noise, lighting or other emissions.</p>	
<p><b>A2</b></p> <p>External lighting for a use, excluding Natural and Cultural Values Management, on a site within 50m of a General Residential Zone, Inner Residential Zone or Low Density Residential Zone, must:</p> <p>(a) not operate within the hours of 11.00pm to 6.00am, excluding any security lighting; and</p> <p>(b) if for security lighting, be baffled so that direct light does not extend into the adjoining property in those zones.</p>	<p><b>P2</b></p> <p>External lighting for a use, excluding Natural and Cultural Values Management, on a site within 50m of a General Residential Zone, Inner Residential Zone or Low Density Residential Zone, must not cause an unreasonable loss of amenity to the residential zones, having regard to:</p> <p>(a) the level of illumination and duration of lighting; and</p> <p>(b) the distance to habitable rooms of an adjacent dwelling.</p>	
<p><b>A3</b></p> <p>Commercial vehicle movements and the unloading and loading of commercial vehicles for a use, excluding Emergency Services, Residential or Visitor Accommodation, on a site within 50m of a General Residential Zone, Inner Residential Zone or Low Density Residential Zone, must be within the hours of:</p> <p>(a) 7.00am to 9.00pm Monday to Saturday; and</p> <p>(b) 8.00am to 9.00pm Sunday and public holidays.</p>	<p><b>P3</b></p> <p>Commercial vehicle movements and the unloading and loading of commercial vehicles for a use, excluding for Emergency Services, Residential or Visitor Accommodation, on a site within 50m of a General Residential Zone, Inner Residential Zone or Low Density Residential Zone, must not cause an unreasonable loss of amenity to the residential zones, having regard to:</p> <p>(a) the time and duration of commercial vehicle movements;</p> <p>(b) the number and frequency of commercial vehicle movements;</p> <p>(c) the size of commercial vehicles involved;</p> <p>(d) manoeuvring required by the commercial vehicles, including the amount of reversing and associated warning noise;</p> <p>(e) any noise mitigation measures between the vehicle movement areas and the residential zone; and</p> <p>(f) potential conflicts with other traffic.</p>	

CCO-P1.5.2 Discretionary uses

<b>Objective:</b>	That uses listed as Discretionary do not: (a) cause unreasonable loss of amenity to adjoining residential zones; and (b) compromise or distort the activity centre hierarchy.	
<b>Acceptable Solutions</b>		<b>Performance Criteria</b>
<b>A1</b> No Acceptable Solution.	<b>P1</b> A use listed as Discretionary must: (a) not cause an unreasonable loss of amenity to properties in adjoining residential zones; and (b) be of an intensity that respects the character of the area.	
<b>A2</b> No Acceptable Solution.	<b>P2</b> A use listed as Discretionary must not compromise or distort the activity centre hierarchy, having regard to: (a) the characteristics of the site; (b) the need to encourage activity at pedestrian levels; (c) the size and scale of the proposed use; (d) the functions of the activity centre and the surrounding activity centres; and (e) the extent that the proposed use impacts on other activity centres.	

CCO-P1.6 Development Standards for Buildings and Works

CCO-P1.6.1 Building height

<b>Objective:</b>	That building height: (a) is compatible with the streetscape; and (b) does not cause an unreasonable loss of amenity to adjoining residential zones.	
<b>Acceptable Solutions</b>		<b>Performance Criteria</b>
<b>A1</b> Building height must be not more than 9m.	<b>P1</b> Building height must be compatible with the streetscape and character of development existing on established properties in the area, having regard to: (a) the topography of the site; (b) the height, bulk and form of existing buildings on the site and adjacent properties; (c) the bulk and form of proposed buildings; (d) the apparent height when viewed from the adjoining road and public places; and (e) any overshadowing of adjoining properties and public places.	

CCO-P1.6.2 Setback

<p><b>Objective:</b></p>	<p>That building setback:</p> <ul style="list-style-type: none"> <li>(a) is compatible with the streetscape;</li> <li>(b) does not cause an unreasonable loss of amenity to adjoining residential zones; and</li> <li>(c) minimises opportunities for crime and anti-social behaviour through setback of buildings.</li> </ul>
<p><b>Acceptable Solutions</b></p>	<p><b>Performance Criteria</b></p>
<p><b>A1</b> No Acceptable Solution.</p>	<p><b>P1</b></p> <p>Buildings must have a setback from a frontage that is compatible with the streetscape and minimises opportunities for crime and anti-social behaviour, having regard to:</p> <ul style="list-style-type: none"> <li>(a) providing small variations in building alignment to break up long building façades;</li> <li>(b) providing variations in building alignment to provide a forecourt space for public use, such as outdoor dining or landscaping;</li> <li>(c) the avoidance of concealment spaces;</li> <li>(d) the ability to achieve passive surveillance; and</li> <li>(e) the availability of lighting.</li> </ul>
<p><b>A2</b></p> <p>Buildings must have a setback from an adjoining property within a General Residential Zone, Inner Residential Zone or Low Density Residential Zone, of not less than:</p> <ul style="list-style-type: none"> <li>(a) 4m; or</li> <li>(b) half the wall height of the building, whichever is the greater.</li> </ul>	<p><b>P2</b></p> <p>Buildings must be sited to not cause an unreasonable loss of amenity to adjoining properties within a General Residential Zone, Inner Residential Zone or Low Density Residential Zone, having regard to:</p> <ul style="list-style-type: none"> <li>(a) overshadowing and reduction in sunlight to habitable rooms and private open space of dwellings;</li> <li>(b) overlooking and reduction of privacy to the adjoining properties; or</li> <li>(c) visual impacts caused by the apparent scale, bulk or proportions of the building when viewed from the adjoining property.</li> </ul>
<p><b>A3</b></p> <p>Air extraction, pumping, refrigeration systems or compressors must be separated a distance of not less than 10m from a General Residential Zone, Inner Residential Zone or Low Density Residential Zone. <sup>1</sup></p>	<p><b>P3</b></p> <p>Air conditioning, air extraction, pumping, heating or refrigeration systems or compressors within 10m of a General Residential Zone, Inner Residential Zone or Low Density Residential Zone, must be designed, located, baffled or insulated to not cause an unreasonable loss of amenity to the adjoining residential zones, having regard to:</p> <ul style="list-style-type: none"> <li>(a) the characteristics and frequency of emissions generated;</li> <li>(b) the nature of the proposed use;</li> <li>(c) the topography of the site and location of the sensitive use; and</li> <li>(d) any proposed mitigation measures.</li> </ul>

<sup>1</sup> An exemption applies for air conditioners and heat pumps in this zone – see Table 4.6.

CCO-P1.6.3 Design

<b>Objective:</b>	That building façades promote and maintain high levels of pedestrian interaction, amenity, and safety, and are compatible with the streetscape.	
<b>Acceptable Solutions</b>		<b>Performance Criteria</b>
<p><b>A1</b></p> <p>New buildings must be designed to satisfy all the following:</p> <ul style="list-style-type: none"> <li>(a) mechanical plant and other service infrastructure, such as heat pumps, air conditioning units, switchboards, hot water units and the like, must be screened from the street and other public places;</li> <li>(b) roof-top mechanical plant and service infrastructure, including lift structures, must be contained within the roof;</li> <li>(c) not include security shutters or grilles over windows or doors on a façade facing the frontage or other public places; and</li> <li>(d) provide external lighting to illuminate external vehicle parking areas and pathways.</li> </ul>	<p><b>P1</b></p> <p>New buildings must be designed to be compatible with the streetscape, having regard to:</p> <ul style="list-style-type: none"> <li>(a) minimising the visual impact of mechanical plant and other service infrastructure, such as heat pumps, air conditioning units, switchboards, hot water units and the like, when viewed from the street or other public places;</li> <li>(b) minimising the visual impact of security shutters or grilles and roof-top service infrastructure, including lift structures; and</li> <li>(c) providing suitable lighting to vehicle parking areas and pathways for the safety and security of users.</li> </ul>	
<p><b>A2</b></p> <p>New buildings or alterations to an existing façade must be designed to satisfy all of the following:</p> <ul style="list-style-type: none"> <li>(a) provide a pedestrian entrance to the building that is visible from the road or publicly accessible areas of the site;</li> <li>(b) if for a ground floor level façade facing a frontage: <ul style="list-style-type: none"> <li>(i) have not less than 40% of the total surface area consisting of windows or doorways; or</li> <li>(ii) not reduce the surface area of windows or doorways of an existing building, if the surface area is already less than 40%;</li> </ul> </li> <li>(c) if for a ground floor level façade facing a frontage must: <ul style="list-style-type: none"> <li>(i) not include a single length of blank wall greater than 30% of the length of façade on that frontage; or</li> <li>(ii) not increase the length of an existing blank wall, if already greater than 30% of the length of the façade on that frontage; and</li> </ul> </li> <li>(d) provide awnings over a public footpath if existing on the site or on adjoining properties.</li> </ul>	<p><b>P2</b></p> <p>New buildings or alterations to an existing façade must be designed to be compatible with the streetscape, having regard to:</p> <ul style="list-style-type: none"> <li>(a) how the main pedestrian access to the building addresses the street or other public places;</li> <li>(b) windows on the façade facing the frontage for visual interest and passive surveillance of public spaces;</li> <li>(c) providing architectural detail or public art on large expanses of blank walls on the façade facing the frontage and other public spaces so as to contribute positively to the streetscape and public spaces;</li> <li>(d) installing security shutters or grilles over windows or doors on a façade facing the frontage or other public spaces only if essential for the security of the premises and any other alternatives are not practical; and</li> <li>(e) the need for provision of awnings over a public footpath.</li> </ul>	

CCO-P1.6.4 Fencing

<b>Objective:</b>	That fencing: (a) is compatible with the streetscape; and (b) does not cause an unreasonable loss of residential amenity to adjoining residential zones.	
<b>Acceptable Solutions</b>		<b>Performance Criteria</b>
<b>A1</b> No Acceptable Solution. <sup>2</sup>	<b>P1</b> A fence (including a free-standing wall) within 4.5m of a frontage must contribute positively to the streetscape, having regard to:  (a) its height, design, location and extent; (b) its degree of transparency; and (c) the proposed materials and construction.	
<b>A2</b> Common boundary fences with a property in a General Residential Zone, Inner Residential Zone or Low Density Residential Zone, if not within 4.5m of a frontage, must:  (a) have a height above existing ground level of not more than 2.1m; and (b) not contain barbed wire.	<b>P2</b> Common boundary fences with a property in a General Residential Zone, Inner Residential Zone or Low Density Residential Zone, if not within 4.5m of a frontage, must not cause an unreasonable loss of residential amenity, having regard to:  (a) their height, design, location and extent; and (b) the proposed materials and construction.	

<sup>2</sup> An exemption applies for fences in this zone – see Table 4.6.

CCO-P1.6.5 Outdoor storage areas

<b>Objective:</b>	That outdoor storage areas for non-residential use do not detract from the appearance of the site or surrounding area.	
<b>Acceptable Solutions</b>		<b>Performance Criteria</b>
<b>A1</b> Outdoor storage areas, excluding for the display of goods for sale, must not be visible from any road or public open space adjoining the site.	<b>P1</b> Outdoor storage areas, excluding for the display of goods for sale, must be located, treated or screened to not cause an unreasonable loss of visual amenity.	

CCO-P1.7 Development Standards for Subdivision

CCO-P1.7.1 Lot design

<p><b>Objective:</b></p>	<p>That each lot:</p> <ul style="list-style-type: none"> <li>(a) has an area and dimensions appropriate for use and development in the zone;</li> <li>and</li> <li>(b) is provided with appropriate access to a road.</li> </ul>
<p><b>Acceptable Solutions</b></p>	<p><b>Performance Criteria</b></p>
<p><b>A1</b> No Acceptable Solution.</p>	<p><b>P1</b> Subdivision must be necessary to facilitate an approved use and development on the site.</p>
<p><b>A2</b> Each lot, or a lot proposed in a plan of subdivision, must have a frontage, or legal connection to a road by a right of carriageway, of not less than 3.6m.</p>	<p><b>P2</b> Each lot, or a lot proposed in a plan of subdivision, must be provided with a frontage or legal connection to a road by a right of carriageway, that is sufficient for the intended use, having regard to:</p> <ul style="list-style-type: none"> <li>(a) the number of other lots which have the land subject to the right of carriageway as their sole or principal means of access;</li> <li>(b) the topography of the site;</li> <li>(c) the functionality and useability of the frontage;</li> <li>(d) the anticipated nature of vehicles likely to access the site;</li> <li>(e) the ability to manoeuvre vehicles on the site;</li> <li>(f) the ability for emergency services to access the site; and</li> <li>(g) the pattern of development existing on established properties in the area.</li> </ul>
<p><b>A3</b> Each lot, or a lot proposed in a plan of subdivision, must be provided with a vehicular access from the boundary of the lot to a road in accordance with the requirements of the road authority.</p>	<p><b>P3</b> Each lot, or a lot proposed in a plan of subdivision, must be provided with reasonable vehicular access to a boundary of a lot or building area on the lot, if any, having regard to:</p> <ul style="list-style-type: none"> <li>(a) the topography of the site;</li> <li>(b) the distance between the lot or building area and the carriageway;</li> <li>(c) the nature of the road and the traffic; and</li> <li>(d) the pattern of development existing on established properties in the area.</li> </ul>

CCO-P1.7.2 Services

<b>Objective:</b>	That the subdivision of land provides services for the use and development of the land.	
<b>Acceptable Solutions</b>	<b>Performance Criteria</b>	
<b>A1</b> Each lot, or a lot proposed in a plan of subdivision, excluding for public open space, a riparian or littoral reserve or Utilities, must:  (a) be connected to a full water supply service if the frontage of the lot is within 30m of a full water supply service; or  (b) be connected to a limited water supply service if the frontage of the lot, is within 30m of a connection to a limited water supply service, unless a regulated entity advises that the lot is unable to be connected to the relevant water supply service.	<b>P1</b> No Performance Criterion.	
<b>A2</b> Each lot, or a lot proposed in a plan of subdivision, excluding for public open space, a riparian or littoral reserve or Utilities, must have a connection to a reticulated sewerage system.	<b>P2</b> Each lot, or a lot proposed in a plan of subdivision, excluding for public open space, a riparian or littoral reserve or Utilities, must be capable of accommodating an on-site wastewater treatment system adequate for the future use and development of the land.	
<b>A3</b> Each lot, or a lot on a plan of subdivision, excluding for public open space, a riparian or littoral reserve or Utilities, must be capable of connecting to a public stormwater system.	<b>P3</b> Each lot, or a lot on a proposed plan of subdivision, must be capable of accommodating an on-site stormwater management system adequate for the future use and development of the land, having regard to:  (a) the size of the lot; (b) topography of the site; (c) soil conditions; (d) any existing buildings on the site; (e) any area of the site covered by impervious surfaces; and (f) any watercourse on the land.	

**CCO-P1.8 Tables**

This clause is not used in this particular purpose zone.

**CCO-Specific Area Plans**

**CCO-S1.0 Forth Specific Area Plan**

**CCO-S1.1 Plan Purpose**

The purpose of the Forth Specific Area Plan is:

CCO- To provide a framework to guide the future use and development of the Forth Village and protect the S1.1.1 character and amenity of the Forth Village.

**CCO-S1.2 Application of this Plan**

CCO- The specific area plan applies to the area of land designated as Forth Specific Area Plan on the S1.2.1 overlay maps.

CCO- In the area of land to which this plan applies, the provisions of the specific area plan are in substitution S1.2.2 for, and are in addition to the provisions of the Low Density Residential Zone, as specified in the relevant provision.

**CCO-S1.3 Local Area Objectives**

Reference Number	Area Description	Local Area Objectives
CCO-S1.3.1.1	Forth Specific Area Plan shown on overlay map as CCO-S1.3.1.1.	Use and development is to: <ul style="list-style-type: none"> <li>(a) be designed and located so that it is compatible with the established character and amenity of the Village;</li> <li>(b) be in accordance with the availability and capacity of Utilities;</li> <li>(c) be contained within a compact urban form without expansion on the boundaries of the established settlement area.</li> <li>(d) retain and respect the atmosphere of Forth as a compact village embedded within the picturesque setting of the rural Forth River Valley; and</li> <li>(e) retain and respect the visual characteristics and features of an earlier period of settlement, including:                             <ul style="list-style-type: none"> <li>(i) an internal network of narrow laneways; and</li> <li>(ii) architectural detailing in the form and finish of buildings.</li> </ul> </li> </ul>

**CCO-S1.3 Local Area Objectives**

CCO-S1.3.1 Local Area Objectives

Sub-clause	Area Description	Local Area Objectives
CCO-S1.3.1.1	Forth Specific Area Plan shown on overlay map as CCO-S1.3.1.1.	<p>Use and development is to:</p> <ul style="list-style-type: none"> <li>(a) be designed and located so that it is compatible with the established character and amenity of the Village;</li> <li>(b) be in accordance with the availability and capacity of Utilities;</li> <li>(c) be contained within a compact urban form without expansion on the boundaries of the established settlement area.</li> <li>(d) retain and respect the atmosphere of Forth as a compact village embedded within the picturesque setting of the rural Forth River Valley; and</li> <li>(e) retain and respect the visual characteristics and features of an earlier period of settlement, including: <ul style="list-style-type: none"> <li>(i) an internal network of narrow laneways; and</li> <li>(ii) architectural detailing in the form and finish of buildings.</li> </ul> </li> </ul>

**CCO-S1.4 Definition of Terms**

CCO-S1.4.1 In this Specific Area Plan, unless the contrary intention appears:

Terms	Definition
Forth subdivision area A	means an area shown on an overlay map as Forth subdivision area A.
Forth subdivision area B	means an area shown on an overlay map as Forth subdivision area B.

**CCO-S1.5 Use Table**

This clause is in substitution for Low Density Residential Zone - clause 10.2 Use Table.

Use Class	Qualification
<b>No Permit Required</b>	
Natural and Cultural Values Management	If for conservation, rehabilitation or protection against degradation, but must not include a building or external activity area for information, interpretation, or display of items or for any other use.
Passive Recreation	If for a public park or reserve for the local community.
<b>Permitted</b>	
Residential	If for: (a) a home based business; (b) a secondary residence; (c) a boarding house in which rooms are wholly or partly let in lodgings as a principal place of residence; (d) multiple dwellings, each in a separate dwelling; (e) a single dwelling.
Resource Development	If a community garden for production or ornamental purposes to service the local community and not involve the keeping of animals.
Utilities	If for minor utilities.
Visitor Accommodation	
<b>Discretionary</b>	
Educational and Occasional Care	If for: (a) all day, before or after school child, occasional or out of school hours care; (b) a pre-school; or (c) a primary school.
Emergency Services	If not intended for deployment beyond the local area, or as a facility for training, maintenance, storage, command or administration.
Natural and Cultural Values Management	If not listed as No Permit Required.
Passive Recreation	If not listed as No Permit Required.
<b>Prohibited</b>	
All other uses	

**CCO-S1.6 Use Standards**

This clause is not used in this specific area plan.

**CCO-S1.7 Development Standards for Buildings and Works**

CCO-S1.7.1 Design and location of development

This clause is in substitution for Low Density Residential Zone - clauses 10.4.2 Building height and 10.5.1 Non-dwelling development A1 and P1 and in addition to Low Density Residential Zone - clauses 10.4 Development Standards for Dwellings and 10.5 Development Standards for Non-dwellings.

<b>Objective:</b>	The design and location of new development is compatible with the attributes and features contributing to the local character of Forth.
<b>Acceptable Solutions</b>	<b>Performance Criteria</b>
<p><b>A1</b></p> <p>An addition to a building must be:</p> <ul style="list-style-type: none"> <li>(a) located to the rear of the existing building; and</li> <li>(b) not more than the building height of the existing building.</li> </ul>	<p><b>P1</b></p> <p>The design and location of a building must maintain the local character attributes and features of existing development in terms of:</p> <ul style="list-style-type: none"> <li>(a) the integrity of the fabric and structure of the building, place or area;</li> <li>(b) the setback, scale, and height of the building elements relative to existing development on the site and on adjacent land;</li> <li>(c) vegetation and other improvement on the site or on adjacent land;</li> <li>(d) local building, place or area, including: <ul style="list-style-type: none"> <li>(i) roof form and pitch;</li> <li>(ii) fenestration;</li> <li>(iii) method and technique of construction;</li> <li>(iv) external fabric, materials and finish;</li> <li>(v) colour scheme;</li> <li>(vi) alterations and additions;</li> <li>(vii) addition;</li> <li>(viii) garden design, planting and any structure; and</li> <li>(ix) fencing.</li> </ul> </li> </ul>

<p><b>A2</b> Building height must be not more than 5.5m.</p>	<p><b>P2</b> Building height must maintain the local character attributes and features of existing development in terms of:</p> <ul style="list-style-type: none"> <li>(a) the integrity of the fabric and structure of the building, place or area;</li> <li>(b) the setback, scale, and height of the building relative to existing development on the site and on adjacent land;</li> <li>(c) vegetation and other improvement on the site or on adjacent land;</li> <li>(d) separation of buildings and external activity areas from a frontage;</li> <li>(e) local building, place or area, including:             <ul style="list-style-type: none"> <li>(i) roof form and pitch;</li> <li>(ii) fenestration;</li> <li>(iii) methods and techniques of construction;</li> <li>(iv) external fabric, materials and finish;</li> <li>(v) colour scheme;</li> <li>(vi) additions;</li> <li>(vii) any outbuilding;</li> <li>(viii) garden design, planting and structures; and</li> <li>(ix) fencing.</li> </ul> </li> </ul>
--	--

CCO-S1.8.1 Lot design

This clause is in substitution for Low Density Residential Zone - clauses 10.6.1 Lot design A1 and P1.

<b>Objective:</b>	That each lot is: (a) connected to utilities for sewerage and stormwater or contains a minimum area for the safe disposal of wastewater; and (b) large enough to conserve the appearance and character of Forth.
<b>Acceptable Solutions</b>	<b>Performance Criteria</b>
<p><b>A1</b></p> <p>Each lot, or lot proposed in a plan of subdivision must</p> <p>(a) have an area of not less than:</p> <p>(i) 4,000m<sup>2</sup> in Forth subdivision area A; or</p> <p>(ii) 2,000m<sup>2</sup> in Forth subdivision area B; and</p> <p>(iii) be able to contain a minimum area of 10m x 15m with a gradient not steeper than 1 in 5, clear of:</p> <p>a. all setbacks required by clause 10.4.3 A1 and A2; and</p> <p>b. easements or other title restrictions that limit or restrict development; and</p> <p>(iv) existing buildings are consistent with the setback required by clause 10.4.3 A1 and A2; or</p> <p>(b) be required for public use by the Crown, a council or a State authority;</p> <p>(c) be required for the provision of Utilities; or</p> <p>(d) be for the consolidation of a lot with another lot provided each lot is within the same zone.</p>	<p><b>P1</b></p> <p>Each lot, or a lot proposed in a plan of subdivision, must have sufficient useable area and dimensions suitable for its intended use, having regard to:</p> <p>(a) the relevant requirements for development of buildings on the lots;</p> <p>(b) the intended location of buildings on the lots;</p> <p>(c) the topography of the site;</p> <p>(d) adequate provision of private open space;</p> <p>(e) the pattern of development existing on established properties in the area; and</p> <p>(f) any constraints to development,</p> <p>and must have an area not less than 4,000m<sup>2</sup> in Forth subdivision area A, or 2,000m<sup>2</sup> in Forth subdivision area B.</p>

**CCO-S1.9 Tables**

This clause is not used in this specific area plan.

**CCO-S2.0 Leith Specific Area Plan**

**CCO-S2.1 Plan Purpose**

The purpose of the Leith Specific Area Plan is:

CCO- To provide for a subdivision density for Leith consistent with existing spatial character.  
S2.1.1

CCO- To maintain the quality of the land, air and water resources of Leith.  
S2.1.2

**CCO-S2.2 Application of this Plan**

CCO- This specific area plan applies to the area of land designated as Leith Specific Area Plan on the  
S2.2.1 overlay maps.

CCO- In the area of land this plan applies to, the provisions of the specific area plan are in substitution to,  
S2.2.2 the provisions of the Low Density Residential Zone, as specified in the relevant provision.

**CCO-S2.3 Local Area Objectives**

CCO-S2.3.1 Local Area Objectives

Reference Number	Area Description	Local Area Objectives
CCO-S2.3.1.1	Leith Specific Area Plan shown on an overlay map as CCO-S2.3.1.1.	The local are objectives of the Leith Specific Area Plan are to: <ul style="list-style-type: none"> <li>(a) protect and conserve the existing spatial characteristics and dwelling densities of Leith; and</li> <li>(b) provide for development that is able to be serviced without an adverse impact on the land, air and water resources of Leith.</li> </ul>

**CCO-S2.4 Definition of Terms**

This clause is not used in this specific area plan.

**CCO-S2.5 Use Table**

This clause is not used in this specific area plan.

**CCO-S2.6 Use Standards**

This clause is not used in this specific area plan.

**CCO-S2.7 Development Standards for Buildings and Works**

This clause is not used in this specific area plan.

**CCO-S2.8 Development Standards for Subdivision**

CCO-S2.8.1 Lot design

This clause is in substitution for Low Density Residential Zone - clause 10.6.1 Lot design A1 and P1, and clause 10.6.3 Services A2, A3 and P2, P3.

<p><b>Objective:</b></p>	<p>That each lot:</p> <ul style="list-style-type: none"> <li>(a) has an area and dimensions appropriate for use and development in Leith;</li> <li>(b) is provided with appropriate access to a road;</li> <li>(c) contains areas which are suitable for residential development; and</li> <li>(d) can accommodate on-site drainage and wastewater and stormwater disposal without adversely impacting adjoining land.</li> </ul>
<p><b>Acceptable Solutions</b></p>	<p><b>Performance Criteria</b></p>
<p><b>A1</b></p> <p>Each lot, or a lot proposed in a plan of subdivision, must:</p> <ul style="list-style-type: none"> <li>(a) have an area of not less than 4,000m<sup>2</sup> and: <ul style="list-style-type: none"> <li>(i) be able to contain a minimum area of 10m x 15m with a gradient not steeper than 1 in 5, clear of: <ul style="list-style-type: none"> <li>a. all setbacks required by clause 10.4.3 A1 and A2; and</li> <li>b. easements or other title restrictions that limit or restrict development; and</li> </ul> </li> <li>(ii) existing buildings are consistent with the setback required by clause 10.4.3 A1 and A2;</li> </ul> </li> <li>(b) be required for public use by the Crown, a council or a State authority;</li> <li>(c) be required for the provision of Utilities; or</li> <li>(d) be for the consolidation of a lot with another lot provided each lot is within the same zone.</li> </ul>	<p><b>P1</b></p> <p>Each lot, or a lot proposed in a plan of subdivision, must have sufficient useable area and dimensions suitable for its intended use having regard to:</p> <ul style="list-style-type: none"> <li>(a) the relevant requirements for development of buildings on the lots;</li> <li>(b) the intended location of buildings on the lots;</li> <li>(c) the topography of the site;</li> <li>(d) adequate provision of private open space;</li> <li>(e) the pattern of development existing on established properties in the area;</li> <li>(f) the capability of accommodating on-site wastewater treatment systems and on-site stormwater management systems;</li> <li>(g) cumulative impacts of on-site wastewater and stormwater disposal on the land, air and water resources of the Leith Specific Area Plan;</li> <li>(h) any constraints to development;</li> <li>(i) the local area objectives in this Specific Area Plan,</li> </ul> <p>and must have an area not less than 2,500m<sup>2</sup>.</p>

**CCO-S2.9 Tables**

This clause is not used in this specific area plan.

**CCO-S3.0 Penguin Specific Area Plan**

**CCO-S3.1 Plan Purpose**

The purpose of the Penguin Specific Area Plan is:

- CCO- S3.1.1 To conserve and complement the historical and cultural attributes that contribute to the coastal village character of the coastal settlement at Penguin without replicating existing built form.
- CCO- S3.1.2 To strengthen attraction and quality of the town of Penguin as a place to live, work and visit by fostering a vibrant and active town centre.
- CCO- S3.1.3 To promote increased density residential development compatible with the coastal village character.
- CCO- S3.1.4 To encourage building design and landscape improvements that are sympathetic to the coastal landscape, complement existing buildings, and protect important vistas to the foreshore and rural hinterland.
- CCO- S3.1.5 To provide consistency in treatment and presentation of buildings and public spaces to create an active street frontage and a high standard of aesthetic and functional amenity by requiring building design that allow visual and physical connection between adjacent buildings and the coastal and rural setting in which the coastal village is located.
- CCO- S3.1.6 To provide a high level of pedestrian, cycling and vehicular movement and connectivity within the town of Penguin.

**CCO-S3.2 Application of this Plan**

- CCO- S3.2.1 This specific area plan applies to the area of land designated as Penguin Specific Area Plan on the overlay maps.
- CCO- S3.2.2 In the area of land this plan applies to, the provisions of the specific area plan are in substitution for, and are in addition to the provisions of the:
  - (a) Local Business Zone;
  - (b) Parking and Sustainable Transport Code, as specified in the relevant provision.

**CCO-S3.3 Local Area Objectives**

This clause is not used in this specific area plan.

**CCO-S3.4 Definition of Terms**

CCO-S3.4.1 In this specific area plan, unless the contrary intention appears:

Terms	Definition
active street frontage	means a frontage that promotes an interesting and safe pedestrian environment in combination with non-residential uses such as retail, restaurants and cafés if accessible directly from the street.

building  
rhythm

means the streetscape that is created by variation in the scale, height and separation between adjoining buildings and which enables visual linkages from a street to the hinterland or the sea, as illustrated by Figure CCO-S3.1.

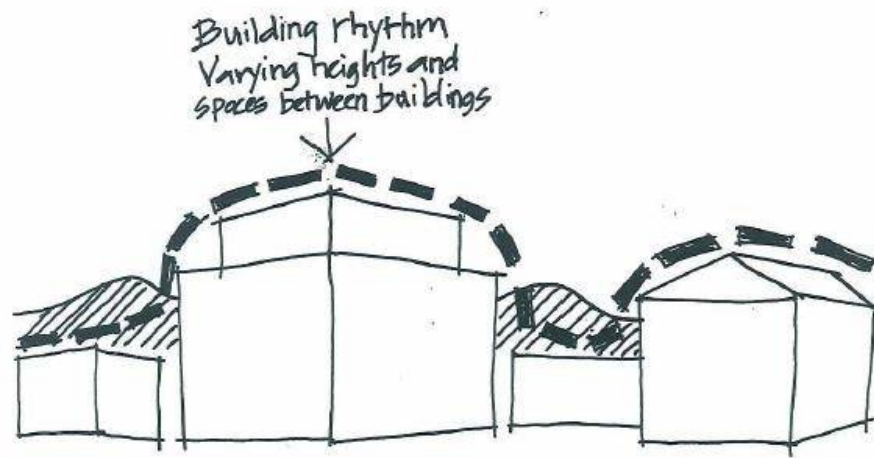
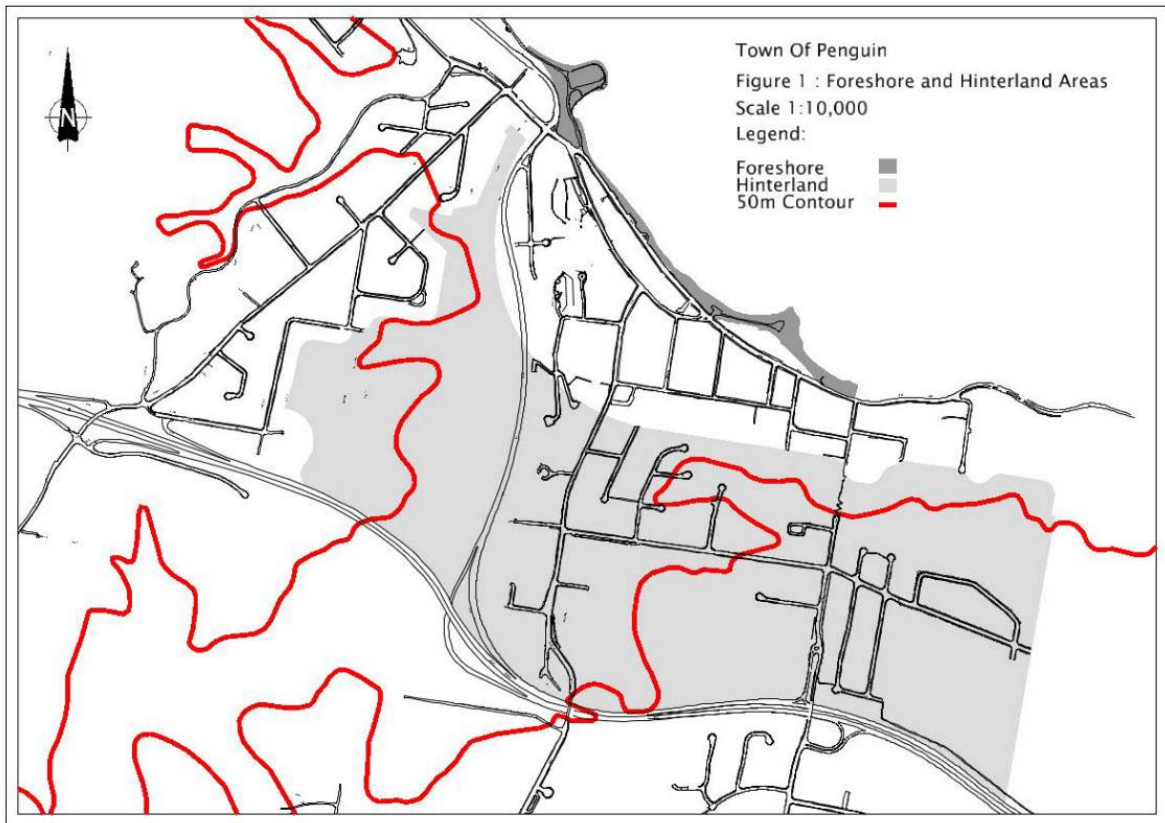

Figure CCO-S3.1 Showing building rhythm.

<p>coastal village character</p>	<p>means the visual and special characteristics, building rhythm, heritage buildings, and open space areas along the foreshore that provide a sense of identifiable place and an important coastal outlook.</p> <p>More specifically the coast village character of Penguin is defined by the interdependent relationship of physical and special elements including:</p> <ul style="list-style-type: none"> <li>(a) the topography of Penguin in combination with the scale and massing of buildings enable retention of visual linkages from ground level between the village centre and those areas of the coastal and rural setting shown on Figure CCO-S3.2;</li> <li>(b) a predominance of one and two storey buildings enable the village centre to remain of a scale that does not dominate the physical landscape when viewed from above at the 50m contour level;</li> <li>(c) a predominance of buildings within the village centre that maintain a separation along the side boundary from immediately adjoining buildings to enable visual linkages through the building mass to the coastal or rural setting;</li> <li>(d) the presence of a rail way line that compels and reinforces the separation of buildings and creates a linear corridor that dissects the village centre;</li> <li>(e) a contrast between the location of buildings onto the frontage within the village centre and the typical set back of buildings from the frontage within the immediately adjacent residential area;</li> <li>(f) building facades within the village centre typically emphasise vertical over horizontal elements;</li> <li>(g) buildings within the village centre typically provide direct pedestrian and visual access between the frontage and the interior by the placement of doors and windows within the frontage elevation;</li> <li>(h) retention of a buildings with a variety of architectural styles from earlier periods of development, and a notable prominence of buildings from the Victorian period;</li> <li>(i) a constrained use of advertising and promotion signs, with signage typically affixed to walls and windows and absent pylon and projecting sign structures;</li> <li>(j) location of car parking and service vehicles facilities to the rear of buildings; and</li> <li>(k) a network of linked pedestrian pathways servicing the foreshore, commercial and residential areas of the village.</li> </ul>
<p>continuous wall</p>	<p>means any wall with staggered setbacks or projections less than 2m deep.</p>
<p>foreshore</p>	<p>means the area depicted as such on Figure CCO-S3.2.</p>
<p>hinterland</p>	<p>means the area depicted as such on Figure CCO-S3.2.</p>

Figure CCO-S3.2 - Areas of foreshore and hinterland as required by clause CCO-S3.4.1



**CCO-S3.5 Use Table**

This clause is not used in this specific area plan.

**CCO-S3.6 Use Standards**

This clause is not used in this specific area plan.

**CCO-S3.7 Development Standards for Buildings and Works**

CCO-S3.7.1 Building design

This clause is in substitution for Local Business Zone - clause 14.4.1 Building height and in addition to Local Business Zone - clause 14.4 Development Standards for Buildings and Works.

<b>Objective:</b>	Buildings must: (a) protect and maintain the human scale of buildings within the Penguin Specific Area Plan; and (b) be in keeping with the coastal village character.
<b>Acceptable Solutions</b>	<b>Performance Criteria</b>
<p><b>A1</b> Building height must be not more than 8m.</p>	<p><b>P1</b> Building height must: (a) be compatible with the coastal village character; (b) reflect the existing building rhythm within the town of Penguin; and (c) be not more than 10m.</p>
<p><b>A2</b> A continuous wall of a building must be not more than: (a) 16m, measured parallel to the frontage or rear boundary; and (b) 20m, measured parallel to the applicable side boundary.</p>	<p><b>P2</b> The continuous wall of a building must: (a) be compatible with the coastal village character; and (b) reflect the existing building rhythm within the town of Penguin.</p>

CCO-S3.7.2 Location and configuration of buildings

This clause is in substitution for Local Business Zone - Clause 14.4.2 Setback A1, A2 and P1, P2.

<p><b>Objective:</b></p>	<p>The location and configuration of a building must:</p> <ul style="list-style-type: none"> <li>(a) protect and maintain the amenity of land and views of the foreshore and the hinterland within the Penguin Specific Area Plan; and</li> <li>(b) be in keeping with the coastal village character.</li> </ul>
<p><b>Acceptable Solutions</b></p>	<p><b>Performance Criteria</b></p>
<p><b>A1</b></p> <p>A building must:</p> <ul style="list-style-type: none"> <li>(a) be located onto the primary and secondary frontage if the wall height is not more than 6.0m;</li> <li>(b) for that part of the building with a wall height of not more than 6.0m: <ul style="list-style-type: none"> <li>(i) onto one side boundary; and</li> <li>(ii) not less than 2.0m or half the wall height on the other side boundary, whichever is the greater; and</li> </ul> </li> <li>(c) for that part of the building with a wall height of more than 6.0m, not less than half the wall height from all boundaries, as illustrated by figure CCO-S3.3.</li> </ul>	<p><b>P1</b></p> <p>The setback of a building:</p> <ul style="list-style-type: none"> <li>(a) must provide within the frontage for that part of a building with a wall height of not more than 6.0m: <ul style="list-style-type: none"> <li>(i) a courtyard, garden or outdoor dining area between a building and the frontage; and</li> <li>(ii) the courtyard, garden or outdoor dining area is in keeping with the coastal village character; or</li> </ul> </li> <li>(b) for that part of a building with a wall height of not more than 6.0m, the side boundary setbacks must: <ul style="list-style-type: none"> <li>(i) be compatible with the coastal village character;</li> <li>(ii) not cause unreasonable over shadowing or loss of privacy to adjoining sites;</li> <li>(iii) reflect the existing building rhythm of Penguin;</li> <li>(iv) maintain views between buildings to the foreshore; and</li> <li>(v) maintain views from the foreshore and Main Road to the hinterland.</li> </ul> </li> <li>(c) for that part of a building with a wall height of more than 6.0m, the setback from all boundaries must: <ul style="list-style-type: none"> <li>(i) be compatible with the coastal village character;</li> <li>(ii) not cause unreasonable over-shadowing or loss of privacy to adjoining sites; and</li> <li>(iii) reflect the existing building rhythm of Penguin, as illustrated by figure CCO-S3.4;</li> <li>(iv) maintain views between buildings to the foreshore, as illustrated by figure CCO-S3.5; and</li> <li>(v) maintain views from the foreshore and Main Street to the hinterland, as illustrated by figure CCO-S3.6.</li> </ul> </li> </ul>

Figure CCO-S3.3 Showing setback of a wall height more than 6m as required by clause CCO-S3.7.2 A1(c)

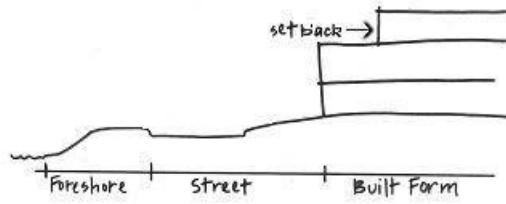

Figure CCO-S3.4 Building rhythm with alternating built and natural views as required by clause CCO-S3.7.2 P1(c)(iii)

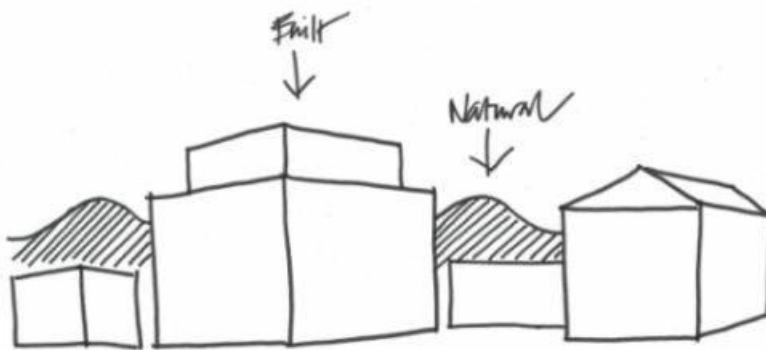

Figure CCO-S3.5 Maintaining views between buildings as required by clause CCO-S3.7.2 P1(c)(iv)

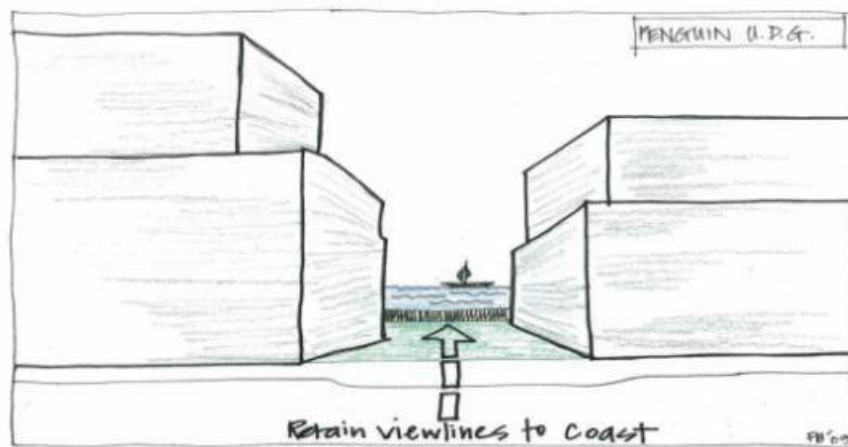
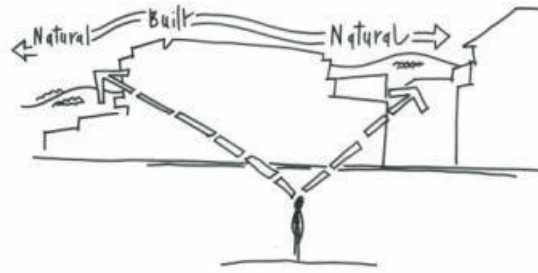

Figure CCO-S3.6 Hinterland views from foreshore as required by clause CCO-S3.7.2 P1(c)(v)



**CCO-S3.7.3 Access and off-street car parking**

This clause is in substitution to Parking and Sustainable Transport code - clause C2.68 Siting of parking and turning areas, and in addition to Local Business Zone - clause 14.4 Development Standards for Building and Works.

<b>Objective:</b>	That development maintains and encourage improvement to: (a) the quality and function of the streetscape; and (b) off-street car parking is not visible from any public area.	
<b>Acceptable Solutions</b>	<b>Performance Criteria</b>	
<b>A1</b> Off-street car parking in the Local Business Zone must:  (a) be located to the rear or within side boundaries of a site;  (b) below natural ground level; or  (c) be screened from public view.	<b>P1</b> The location of off-street car parking in the Local Business Zone must contribute to improved visual amenity and be compatible with the coastal village character.	
<b>A2</b> Access across the frontage to Main Road, Penguin must be obtained using an existing lawful constructed access.	<b>P2</b> Access across the frontage to Main Road, Penguin must minimise likelihood for conflict between vehicles and pedestrians.	

**CCO-S3.8 Development Standards for Subdivision**

This clause is not used in this specific area plan.

**CCO-S3.9 Tables**

This clause is not used in this specific area plan.

**CCO-S4.0 Revell Lane Specific Area Plan**

**CCO-S4.1 Plan Purpose**

The purpose of the Revell Lane Specific Area Plan is:

CCO- To provide a framework for the appropriate development of the Revell Lane precinct.  
S4.1.1

**CCO-S4.2 Application of this Plan**

CCO- This Specific Area Plan applies to the area of land designated as Revell Lane Specific Area Plan on S4.2.1 the overlay maps.

CCO- In the area of land this plan applies to, the provisions of the specific area plan are in substitution for, S4.2.2 and are in addition to the provisions of the Rural Living Zone, as specified in the relevant provision.

**CCO-S4.3 Local Area Objectives**

CCO-S4.3.1 Local Area Objectives

Reference Number	Area Description	Local Area Objectives
CCO-S4.3.1.1	Revell Lane Specific Area Plan shown on an overlay map as CCO-S4.3.1.1.	<p>The local area objectives of the Revell Lane Specific Area Plan are to:</p> <ul style="list-style-type: none"> <li>(a) provide that the area functions primarily as a rural living area limited by geotechnical and access constraints but with capacity for other uses that are consistent with the provision of a high level of residential amenity;</li> <li>(b) ensure that the skylines in the area are protected from intrusive development;</li> <li>(c) provide for the adequate separation of buildings to reflect a rural character;</li> <li>(d) retain, as far as is reasonable, significant view corridors from properties in and around the Revell Lane Specific Area Plan;</li> <li>(e) require that the type and density of future development (including subdivision) is consistent with the capacity of available services, particularly vehicle access;</li> <li>(f) provide for properties served by Revell Lane to be limited to activities that only generate low traffic volumes;</li> <li>(g) require properties other than those served by Revell Lane make use of available access points to the surrounding road network excluding to the Preservation Drive Secondary Road, unless or until its Limited Access status is removed;</li> <li>(h) provide that the functions and qualities of Penguin Creek and its tributaries, are protected from the adverse effects of development, including erosion, sedimentation, water contamination and adverse changes to run-off patterns;</li> <li>(i) provide for the judicious planting of cleared and elevated areas in order to soften the visual impact of development on the skyline and stabilise areas of land instability;</li> <li>(j) require future development is undertaken in locations and a manner that provides a tolerable level of risk from landslide hazard and does not cause any added risk to the environment or other properties in the area;</li> <li>(k) function primarily as a rural living area but with a lower residential density than is provided for under the Rural Living zone to assist geotechnical and access constraints to be taken into consideration;</li> <li>(l) contain buildings that have a low impact in the landscape generally and from principal viewing points in particular; and</li> <li>(m) be progressively planted with native vegetation on exposed, elevated and cleared hilltop areas around the town of Penguin in order to soften the impact of the buildings on the skyline and to stabilise areas of doubtful land stability.</li> </ul>

**CCO-S4.4 Definition of Terms**

This clause is not used in this specific area plan.

**CCO-S4.5 Use Table**

This clause is in substitution for Rural Living Zone - clause 11.2 Use Table.

<b>Use Class</b>	<b>Qualification</b>
<b>No Permit Required</b>	
Natural and Cultural Values Management	If for conservation, rehabilitation or protection against degradation, but must not include a building or external activity area for information, interpretation or display of items or for any other use.
Passive Recreation	If for a public park or reserve for the local community.
<b>Permitted</b>	
Residential	If for a dwelling or home-based business.
Resource Development	If for: (a) a community garden for production or ornamental purposes to service the local community; or (b) an agricultural use dependent on the soil as a growth medium undertake in association with a residential use.
Utilities	If for minor utilities.
Visitor Accommodation	
<b>Discretionary</b>	
Natural and Cultural Values Management	If not listed as No Permit Required.
Residential	If not listed as Permitted.
Resource Processing	If: (a) for processing produce grown or raised on the site; and (b) off-site impact are minimal and can be managed to minimise conflict or impact on the amenity of any other uses.
Passive Recreation	If not listed as No Permit Required.
Utilities	If not listed as Permitted.
<b>Prohibited</b>	
All other uses	

**CCO-S4.6 Use Standards**

CCO-S4.6.1 Discretionary uses

This clause is in addition to Rural Living Zone - clause 11.3.1 Discretionary uses.

<b>Objective:</b>	Discretionary uses should be limited to those which are consistent with the provision of a high level of residential amenity and do not place any undue load on available services, including vehicle access.	
<b>Acceptable Solutions</b>		<b>Performance Criteria</b>
<b>A1</b>	No Acceptable Solution.	<b>P1</b> Discretionary use must: <ul style="list-style-type: none"> <li>(a) be consistent with local area objectives;</li> <li>(b) minimise likelihood for adverse impact on the amenity for residential use on adjacent land; and</li> <li>(c) be consistent with the capacity of available services, including road access.</li> </ul>

**CCO-S4.7 Development Standards for Buildings and Works**

CCO-S4.7.1 Siting and design

This clause is in substitution for Rural Living Zone - clause 11.4.2 Building height, setback and siting A1 and P1.

<b>Objective:</b>	Buildings should be suitably sited and designed to: <ul style="list-style-type: none"> <li>(a) avoid projection above the skyline from important viewing locations including the Penguin town centre and Bass Highway; and</li> <li>(b) retain significant view corridors from properties in and around the Revell Lane Specific Area Plan, in particular views of the coast, the town centre and Bass Strait.</li> </ul>	
<b>Acceptable Solutions</b>		<b>Performance Criteria</b>
<b>A1</b>	Building height must: <ul style="list-style-type: none"> <li>(a) be not more than 5.5m, or</li> <li>(b) if the entire building is:                             <ul style="list-style-type: none"> <li>(i) not less than 15m below the skyline; or</li> <li>(ii) below the existing tree canopy, be not more than 8.5m.</li> </ul> </li> </ul>	<b>P1</b> Building height and siting must: <ul style="list-style-type: none"> <li>(a) avoid any inappropriate intrusion of the building into the skyline, particularly when viewed from the Penguin town centre and Bass Highway; and</li> <li>(b) retain significant view corridors from properties in and around the Revell Lane Specific Area Plan to a reasonable extent, in particular views along the coast, to the town centre or to Bass Strait.</li> </ul>

**CCO-S4.8 Development Standards for Subdivision**

CCO-S4.8.1 Lot size

This clause is in substitution for Rural Living Zone - clause 11.5.1 Lot design

<p><b>Objective:</b></p>	<p>The minimum properties of a site or lot on a plan of subdivision are to:</p> <ul style="list-style-type: none"> <li>(a) provide a suitable development area for the intended use;</li> <li>(b) provide adequate access from a road;</li> <li>(c) make adequate provision for a water supply and for the drainage and disposal of sewage and stormwater; and</li> <li>(d) limit the density of development to a level that is consistent with the capacity of services, particularly vehicle access and the desired character of the Revell Lane Specific Area Plan.</li> </ul>
<p><b>Acceptable Solutions</b></p>	<p><b>Performance Criteria</b></p>
<p><b>A1</b></p> <p>Each lot, or a lot proposed on a plan of subdivision, must:</p> <ul style="list-style-type: none"> <li>(a) have an area of not less than 2ha; and</li> <li>(b) if intended for a building, contain a building area: <ul style="list-style-type: none"> <li>(i) of not more than 1,000m<sup>2</sup>;</li> <li>(ii) clear of all setbacks required by clause 11.4.2;</li> <li>(iii) clear of any registered easement;</li> <li>(iv) clear of any registered right of carriageway;</li> <li>(v) clear of any restriction imposed by a utility;</li> <li>(vi) not including any access strip;</li> <li>(vii) clear of any area required for the on-site disposal of sewage or stormwater; and</li> <li>(viii) accessible from a frontage or access strip.</li> </ul> </li> </ul>	<p><b>P1</b></p> <p>A lot, or lot proposed on a plan of subdivision, must be of sufficient useable area and dimensions suitable for its intended use or development, without constraint interference or offence to:</p> <ul style="list-style-type: none"> <li>(a) an average site area per dwelling of 1ha;</li> <li>(b) erection of a building if required by the intended use;</li> <li>(c) access to the site;</li> <li>(d) use or development of adjacent land;</li> <li>(e) a utility; and</li> <li>(f) any easement or lawful entitlement for access to other land or for a utility.</li> </ul>

**CCO-S4.9 Tables**

This clause is not used in this specific area plan.

**CCO-S5.0 Turners Beach Specific Area Plan**

**CCO-S5.1 Plan Purpose**

The purpose of the Turners Beach Specific Area Plan is:

CCO- S5.1.1 To provide a framework to guide the future development of Turners Beach.

**CCO-S5.2 Application of this Plan**

CCO- This Specific Area Plan applies to the area of land designated as Turners Beach Specific Area Plan S5.2.1 on the overlay maps.

CCO- In the area of land this plan applies to, the provisions of the specific area plan are in substitution for, S5.2.2 and are in addition to the provisions of the General Residential Zone, as specified in the relevant provision.

**CCO-S5.3 Local Area Objectives**

CCO-S5.3.1 Local Area Objectives

Reference Number	Area Description	Local Area Objectives
CCO-S5.3.1.1	Turners Beach Specific Area Plan shown on an overlay map as CCO-S5.3.1.1.	<p>The local area objectives of the Turners Beach Specific Area Plan are to:</p> <ul style="list-style-type: none"> <li>(a) protect and conserve existing native flora and fauna in a natural state;</li> <li>(b) identify areas vulnerable to coastal inundation by the sea;</li> <li>(c) retain access to the foreshore in a manner that is not disruptive to natural processes;</li> <li>(d) maintain and enhance opportunity for visual outlook to the sea and coastal landmarks;</li> <li>(e) retain an eclectic mix of housing styles at suburban density and with characteristic building setbacks to the street;</li> <li>(f) provide for new residential development in waterfront locations of a scale and appearance to nestle within the landscape;</li> <li>(g) provide for buildings that are typically one or two storeys high, oriented to the frontage, and separated from the frontage and internal site boundaries;</li> <li>(h) allow commercial buildings to the frontage;</li> <li>(i) employ low, transparent fencing and vegetation to define the frontage; and side and rear boundary fencing that is unobtrusive in terms of colour and material;</li> <li>(j) typically treat the frontage setback for garden and landscape purposes;</li> <li>(k) use measures such as split-level building design or broken form to minimise the scale and bulk of new buildings and additions to existing buildings;</li> <li>(l) use increased setback distances to minimise any potential privacy loss from buildings that are higher than neighbouring dwellings;</li> <li>(m) manage street trees and remnant vegetation to complement and create view corridors in residential areas;</li> <li>(n) retain the generally informal character of the residential area north of the Bass Highway through appropriate street planting, narrowing of streets, and use of swale drains;</li> <li>(o) limit commercial activity to home occupation and local convenience retail;</li> <li>(p) retain sand dunes at the natural beach profile; and provide access through the dunes only at specific and formalised locations;</li> <li>(q) manage the environmental significance of the River Forth estuary area to retain the Eucalypt forest and under-storey; and</li> <li>(r) restrict new development on sand dunes and the River Forth estuary to minor low impact facilities such as toilets and change rooms, and car parking of a size to minimise loss of vegetation and visual quality.</li> </ul>

**CCO-S5.4 Definition of Terms**

This clause is not used in this specific area plan.

**CCO-S5.5 Use Table**

This clause is in substitution for General Residential Zone - clause 8.2 Use Table.

Use Class	Qualification
<b>No Permit Required</b>	
Natural and Cultural Values Management	If for conservation, rehabilitation, or protect against degradation, not involving a building or outdoor area for information, interpretation or display of items.
Passive Recreation	If for a public park or reserve for the local community.
<b>Permitted</b>	
Residential	If for a: (a) home based business; (b) boarding house in which rooms are wholly or partly let in lodgings as a principal place of residence; (c) multiple dwelling, each in a separate dwellings; or (d) a single dwelling.
Resource Development	If for a community garden for production or ornamental purposes to service the local community and not involve the keeping of animals.
Utilities	If for minor utilities.
Visitor Accommodation	
<b>Discretionary</b>	
Natural and Cultural Values Management	If not listed as No Permit Required.
Educational and Occasional Care	If for: (a) all day, before or after school, occasional or out of school hours care; (b) pre-school; or (c) primary school.
Emergency Services	If not intended for deployment beyond the local area, or as a facility for training, maintenance, storage, command or administration.
Food Services	
Passive Recreation	If not listed as No Permit Required.
Utilities	If not listed as Permitted.
<b>Prohibited</b>	
All other uses	

**CCO-S5.6 Use Standards**

This clause is not used in this specific area plan.

**CCO-S5.7 Development Standards for Buildings and Works**

CCO-S5.7.1 Setbacks and building envelope for all buildings

The Acceptable Solution in this clause is in substitution for General Residential Zone - clause 8.4.2 Setback and building envelope for all dwellings A3 and P3 and clause 8.5.1 Non Dwelling Development A2 and P2.

<p><b>Objective:</b></p>	<p>That building height:</p> <ul style="list-style-type: none"> <li>(a) minimises over-shadowing of adjoining sites;</li> <li>(b) protects privacy of adjoining dwellings; and</li> <li>(c) protects view lines.</li> </ul>
<p><b>Acceptable Solutions</b></p>	<p><b>Performance Criteria</b></p>
<p><b>A1</b></p> <p>A dwelling, excluding outbuildings with a building height of not more than 2.4m and protrusions that extend not more than 0.9m horizontally beyond the building envelope, must:</p> <ul style="list-style-type: none"> <li>(a) be contained within a building envelope (refer to Figures CCO-S5.1, CCO-S5.2 and CCO-S5.3) determined by: <ul style="list-style-type: none"> <li>(i) a distance equal to the frontage setback or, for an internal lot, a distance of 4.5m from the rear boundary of a property with an adjoining frontage; and</li> <li>(ii) projecting a line at an angle of 45 degrees from the horizontal at a height of 3m above existing ground level at the side and rear boundaries to a building height of not more than 5.5m above existing ground level; and</li> </ul> </li> <li>(b) only have a setback of less than 1.5m from a side or rear boundary if the dwelling: <ul style="list-style-type: none"> <li>(i) does not extend beyond an existing building built on or within 0.2m of the boundary of the adjoining property; or</li> <li>(ii) does not exceed a total length of 9m or one third the length of the side boundary (whichever is the lesser).</li> </ul> </li> </ul>	<p><b>P1.1</b></p> <p>The siting and scale of a dwelling must:</p> <ul style="list-style-type: none"> <li>(a) not cause an unreasonable loss of amenity to adjoining properties, having regard to: <ul style="list-style-type: none"> <li>(i) reduction in sunlight to a habitable room (other than a bedroom) of a dwelling on an adjoining property;</li> <li>(ii) overshadowing the private open space of a dwelling on an adjoining property;</li> <li>(iii) overshadowing of an adjoining vacant property; or</li> <li>(iv) visual impacts caused by the apparent scale, bulk or proportions of the dwelling when viewed from an adjoining property;</li> </ul> </li> <li>(b) provide separation between dwellings on adjoining properties that is consistent with that existing on established properties in the area; and</li> <li>(c) not cause an unreasonable reduction in sunlight to an existing solar energy installation on: <ul style="list-style-type: none"> <li>(i) an adjoining property; or</li> <li>(ii) another dwelling on the same site.</li> </ul> </li> </ul> <p><b>P1.2</b></p> <p>Building height of a dwelling must minimise over-shadowing, protect of privacy in adjoining dwellings and protect view lines, having regard to:</p>

- (a) the likelihood for overshadowing of a habitable room or an area of private open space in a dwelling on the site or adjacent land if the resultant period of sunlight is less than 3 hours between 9.00am and 5.00pm on 21<sup>st</sup> of June;
- (b) the likelihood for direct overlooking from a window in a building with a finished floor level more than 1.0m above natural ground level to a habitable room or private open space area in a dwelling on the site or on adjacent land;
- (c) the relationship between appearance and design characteristics of the buildings and any buildings on adjacent land;
- (d) the apparent building height when viewed from a frontage road and adjacent land in another zone;
- (e) the effect of the slope and orientation of the site and adjacent land on apparent building height;
- (f) the effect and durability of screening to attenuate impact of the building to view from a frontage road or from adjacent land in another zone; and
- (g) the protection of view lines enjoyed by existing dwellings,

and is not more than 7.5m.

<p><b>A2</b></p> <p>A building that is not a dwelling, excluding outbuildings with a building height of not more than 2.4m and protrusions that extend not more than 0.9m horizontally beyond the building envelope, must:</p> <p>(a) be contained within a building envelope (refer to Figures CCO-S5.1, CCO-S5.2 and CCO-S5.3) determined by:</p> <ul style="list-style-type: none"> <li>(i) a distance equal to the frontage setback or, for an internal lot, a distance of 4.5m from the rear boundary of a property with an adjoining frontage; and</li> <li>(ii) projecting a line at an angle of 45 degrees from the horizontal at a height of 3m above existing ground level at the side or rear boundaries to a building height of not more than 5.5m above existing ground level; and</li> </ul> <p>(b) only have a setback less than 1.5m from a side or rear boundary if the building:</p> <ul style="list-style-type: none"> <li>(i) does not extend beyond an existing building built on or within 0.2m of the boundary of the adjoining property; or</li> <li>(ii) does not exceed a total length of 9m or one-third of the length of the side or rear boundary (whichever is lesser).</li> </ul>	<p><b>P2.1</b></p> <p>The siting and scale of a building that is not a dwelling must:</p> <p>(a) not cause an unreasonable loss of amenity, having regard to:</p> <ul style="list-style-type: none"> <li>(i) reduction in sunlight to a habitable room, excluding a bedroom, of a dwelling on an adjoining property;</li> <li>(ii) overshadowing the private open space of a dwelling on an adjoining property;</li> <li>(iii) overshadowing of an adjoining vacant property; or</li> <li>(iv) visual impacts caused by the apparent scale, bulk or proportions of the building when viewed from an adjoining property; and</li> </ul> <p>(b) provide separation between buildings on adjoining properties that is consistent with that existing on established properties in the area.</p> <p><b>P2.2</b></p> <p>Building height of a building that is not a dwelling must minimise over-shadowing, protect of privacy in adjoining dwellings and protect view lines, having regard to:</p> <ul style="list-style-type: none"> <li>(a) the likelihood for overshadowing of a habitable room or an area of private open space in a dwelling on the site or adjacent land if the resultant period of sunlight is less than 3 hours between 9.00am and 5.00pm on 21<sup>st</sup> of June;</li> <li>(b) the likelihood for direct overlooking from a window in a building with a finished floor level more than 1.0m above natural ground level to a habitable room or private open space area in a dwelling on the site or on adjacent land;</li> <li>(c) the relationship between appearance and design characteristics of the buildings and any buildings on adjacent land;</li> <li>(d) the apparent building height when viewed from a frontage road and adjacent land in another zone;</li> <li>(e) the effect of the slope and orientation of the site and adjacent land on apparent building height;</li> <li>(f) the effect and durability of screening to attenuate impact of the building to view from a frontage road or from adjacent land in another zone; and</li> <li>(g) the protection of view lines enjoyed by existing dwellings,</li> </ul> <p>and is not more than 7.5m.</p>
--	---

Figure CCO-S5.1 - Building envelope as required by clause CCO-S5.7.1 A1 and A2 that is in substitution for General Residential Zone - clause 8.4.2 A3 and clause 8.5.1 A2

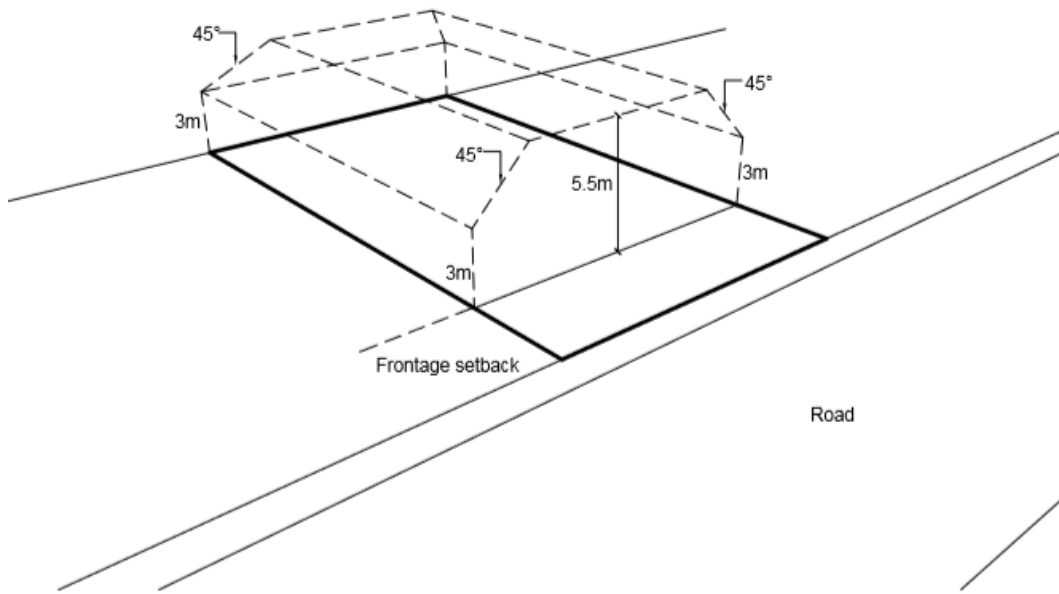

Figure CCO-S5.2 - Building envelope for corner lots as required by clause CCO-S5.7.1 A1 and A2 that is in substitution for General Residential Zone - clause 8.4.2 A3 and clause 8.5.1 A2

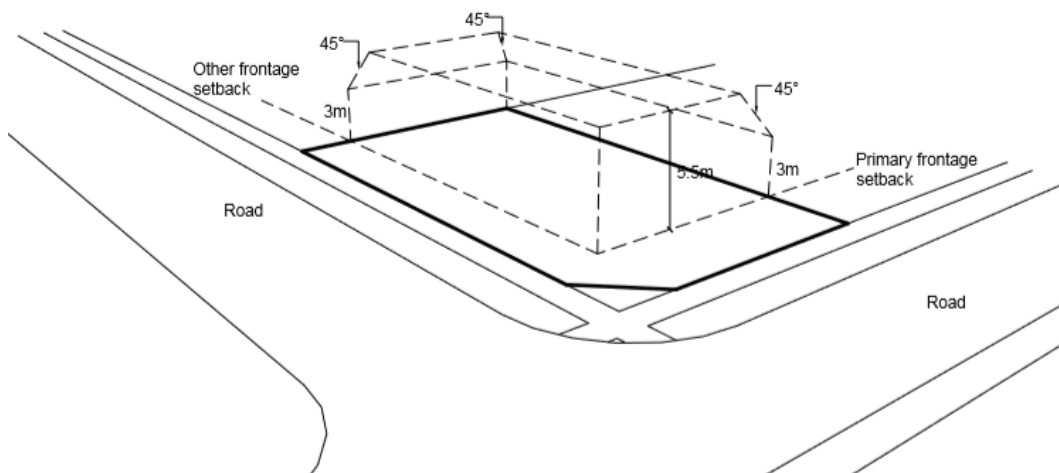
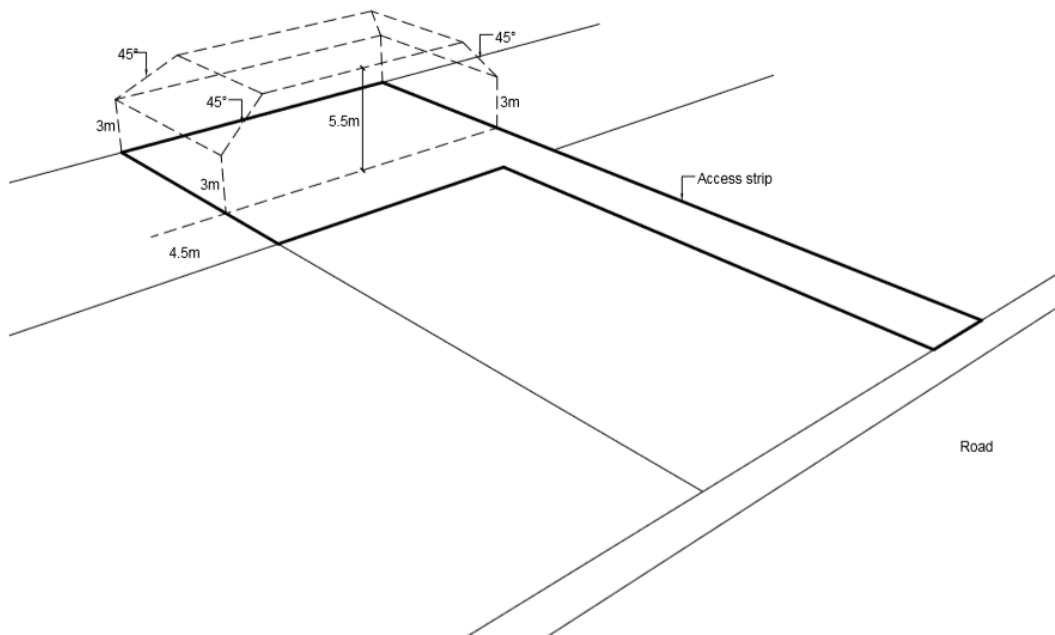

Figure CCO-S5.3 - Building envelope for internal lots as required by clause CCO-S5.1 A1 and A2 that is in substitution for General Residential Zone - clause 8.4.2 A3 and clause 8.5.1 A2



CCO-S5.7.2 Vegetation management

This clause is in addition to General Residential Zone - clause 8.4 Development Standards for Dwellings and clause 8.5. Development Standards for Non-dwellings.

<b>Objective:</b>	Vegetation is managed in a sustainable manner.	
<b>Acceptable Solutions</b>	<b>Performance Criteria</b>	
<b>A1</b> There must be no clearing or conversion of vegetation within the littoral, riparian and road reserves.	<b>P1</b> Clearing and conversion of vegetation within a littoral, riparian or road reserve must:  (a) not adversely impact on the dune and ecosystem;  (b) form part of approved works under a permit for the site;  (c) be required to provide access to a beach or river; or  (d) be for rehabilitation works.	

CCO-S5.7.3 Landscaping

This clause is in addition to General Residential Zone - clause 8.4 Development Standards for Dwellings.

<b>Objective:</b>	The front of the dwelling is landscaped.	
<b>Acceptable Solutions</b>	<b>Performance Criteria</b>	
<b>A1</b> On a site, excluding an internal lot, not less than 50% of the site area between the frontage and a building containing a dwelling must be landscaped with not less than grass.	<b>P1</b> No Performance Criterion.	

CCO-S5.7.4 Beach access

This clause is in addition to General Residential Zone - clause 8.4 Development Standards for Dwellings and clause 8.5. Development Standards for Non-dwellings.

<b>Objective:</b>	Access to the beach or the River Forth is controlled to minimise damage to the ecosystem.	
<b>Acceptable Solutions</b>	<b>Performance Criteria</b>	
<b>A1</b> New vehicular or pedestrian accesses to the beach or River Forth must not be created.	<b>P1</b> Vehicular or pedestrian accesses to the beach or River Forth must:  (a) be required to rationalise and reduce the number of existing access; and  (b) not adversely impact on the coastal dune or river bank ecosystem.	

**CCO-S5.8 Development Standards for Subdivision**

This clause is not used in this specific area plan.

**CCO-S5.9 Tables**

This clause is not used in this specific area plan.

**CCO-Site-Specific Qualifications**

There are no site-specific qualifications in this Local Provisions Schedule.

**CCO-Code Lists**

**CCO-C3.0 Road and Railway Assets Code**

**CCO-Table C3.1 Other Major Roads**

Road	From	To
This table is not used in this Local Provisions Schedule.		

**CCO-C6.0 Local Historic Heritage Code**

**CCO-Table C6.1 Local Heritage Places**

<b>Reference Number</b>	<b>THR Number</b>	<b>Town/Locality</b>	<b>Street Address</b>	<b>Property Name</b>	<b>Folio of the Register</b>	<b>Description, Specific Extent, Statement of Local Historic Heritage Significance and Historic Heritage Values</b>
This table is not used in this Local Provisions Schedule.						

**CCO-Table C6.2 Local Heritage Precincts**

<b>Reference Number</b>	<b>Town/Locality</b>	<b>Name of Precinct</b>	<b>Description, Statement of Local Historic Heritage Significance, Historic Heritage Values and Design Criteria / Conservation Policy</b>
This table is not used in this Local Provisions Schedule.			

**CCO-Table C6.3 Local Historic Landscape Precincts**

<b>Reference Number</b>	<b>Town/Locality</b>	<b>Name of Precinct</b>	<b>Description, Statement of Local Historic Heritage Significance, Historic Heritage Values and Design Criteria / Conservation Policy</b>
This table is not used in this Local Provisions Schedule.			

**CCO-Table C6.4 Places or Precincts of Archaeological Potential**

Reference Number	Town/Locality	Property Name / Address/ Name of Precinct	Folio of the Register	Description, Specific Extent and Archaeological Potential
This table is not used in this Local Provisions Schedule.				

**CCO-Table C6.5 Significant Trees**

Reference Number	Town/Locality	Property Name and Street Address	Folio of the Register	Description / Specific Extent	Botanical Name	Common Name	No. of trees
This table is not used in this Local Provisions Schedule.							

**CCO-C8.0 Scenic Protection Code**

**CCO-Table C8.1 Scenic Protection Areas**

Reference Number	Scenic Protection Area Name	Description	Scenic Value	Management Objectives
CCO-C8.1.1	Leven Canyon/ Loyetea Peak	Leven Canyon Regional Reserve and adjoining Crown land that comprises Loyetea Peak and the "Three Brothers".	The Leven Canyon / Loyetea Peak area is:	<p>Protect the scenic values of the Leven Canyon/ Loyetea Peak area by:</p> <ul style="list-style-type: none"> <li>(a) maintaining undisturbed native vegetation as the dominant landscape element when viewed from public roads and places;</li> <li>(b) maintaining skylines and escarpments and forested slopes free of visible development and fragmentation;</li> <li>(c) retaining the landscape connectivity including the contiguous native forest canopy cover; and</li> <li>(d) avoiding visual contrast between buildings and works and the natural bushland.</li> </ul>

			<p>(a) a wild dramatic landscape set amongst land that is used for grazing, production forestry and residential settlements;</p> <p>(b) a native vegetation area comprising a deep river canyon that accommodates the Leven River with adjoining peaks;</p> <p>(c) an area showcasing a spectacular contiguous natural forest skyline and 400-m-high escarpment and slopes;</p> <p>(d) an area of geological interest unlike any other in Tasmania with world-class limestone geology;</p> <p>(e) an area that offers natural landscape vistas when viewed from the areas of Gunns Plains, Nietta, South Preston, Preston, Loonganna, Black Bluff, the Penguin to Cradle walking trail, and from scenic lookouts; including Loyetea Peak and the Cruickshanks Leven Canyon viewing Platform;</p> <p>and</p>	
--	--	--	---	--

**CCO-Table C8.2 Scenic Road Corridors**

(f) a near-coastal area offering residents and visitors easy access to a wild

Reference Number	Scenic Road Corridor Description	Scenic Value	Management Objectives
This table is not used in this Local Provisions Schedule.		river and canyon scenery and nature from lookouts and tourist places,	

**CCO-C11.0 Coastal Inundation Hazard Code**

thereby providing a key element of the north coast's tourism product.

**CCO-Table C11.1 Coastal Inundation Hazard Bands AHD Levels**

Locality	High Hazard Band (m AHD)	Medium Hazard Band (m AHD)	Low Hazard Band (m AHD)	Defined Flood Level (m AHD)
	Sea Level Rise 2050	1% annual exceedance probability 2050 with freeboard	1% annual exceedance probability 2100 (design flood level) with freeboard	1% annual exceedance probability 2100
Forth	1.8	2.7	3.2	2.9
Gawler	1.8	2.7	3.3	3
Heybridge	1.8	2.7	3.3	3
Leith	1.8	2.7	3.2	2.9
Penguin	1.8	2.7	3.3	3
Sulphur Creek	1.8	2.7	3.3	3
Turners Beach	1.8	2.7	3.3	3
Ulverstone	1.8	2.7	3.3	3
West Ulverstone	1.8	2.7	3.3	3
Central Coast Average	1.8	2.7	3.3	3

**CCO-Applied, Adopted or Incorporated Documents**

Document Title	Publication Details	Relevant Clause in the LPS
This table is not used in this Local Provisions Schedule.		